

HP

ProCurve

Switches and Hubs

HP ProCurve

HP ProCurve Switch 408 Installation Guide

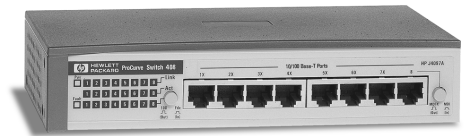

Less Work, More Network
<http://www.hp.com/go/procurve>

HP ProCurve Switch 408

© Copyright 1999 Hewlett-Packard Company All Rights Reserved. Disclaimer

This document contains information which is protected by copyright. Reproduction, adaptation, or translation without prior permission is prohibited, except as allowed under the copyright laws.

Publication Number

J4097-90001
Edition 1
April 1999

Applicable Product

HP ProCurve Switch 408 (HP J4097A)

The information contained in this document is subject to change without notice.

HEWLETT-PACKARD COMPANY MAKES NO WARRANTY OF ANY KIND WITH REGARD TO THIS MATERIAL, INCLUDING, BUT NOT LIMITED TO, THE IMPLIED WARRANTIES OF MERCHANTABILITY AND FITNESS FOR A PARTICULAR PURPOSE. Hewlett-Packard shall not be liable for errors contained herein or for incidental or consequential damages in connection with the furnishing, performance, or use of this material.

Hewlett-Packard assumes no responsibility for the use or reliability of its software on equipment that is not furnished by Hewlett-Packard.

Warranty

A copy of the specific warranty terms applicable to your Hewlett-Packard products and replacement parts can be obtained from your HP Sales and Service Office or authorized dealer.

Safety

Before installing and operating this product, please read the "Installation Precautions" in chapter 2, "Installing the Switch 408", and the safety statements in appendix C, "Safety and EMC Regulatory Statements".

Contents

1 Introducing the Switch 408

Front of the Switch	1-2
Network Ports	1-2
MDI-X/MDI Select Button	1-2
LEDs	1-3
100/Fdx Select Button	1-4
Back of the Switch	1-5
Power Connector	1-5
Features	1-6
Switch Operation Overview	1-6
Address Table Operation	1-6
Simultaneous Network Communications	1-8

2 Installing the Switch 408

Included Parts	2-1
Installation Procedures	2-2
Summary	2-2
Installation Precautions:	2-3
1. Prepare the Installation Site	2-5
2. Verify the Switch Passes Its Self Test	2-6
3. Mount the Switch	2-8
4. Connect the Switch to a Power Source	2-9
5. Connect the Network Cables	2-9

Sample Network Topologies	2-10
As a Desktop Switch	2-10
As a Segment Switch	2-11

3 Troubleshooting

Basic Troubleshooting Tips	3-1
Diagnosing With the LEDs	3-4
Hardware Diagnostic Tests	3-7
Testing the Switch by Resetting It	3-7
Testing Twisted-Pair Cabling	3-7
Testing End-to-End Network Communications	3-8
HP Customer Support Services	3-8

A Specifications

Physical	A-1
Electrical	A-1
Environmental	A-1
Connectors	A-2
Safety	A-2

B Cables and Connectors

Twisted-Pair Cable/Connector Pin-Outs	B-1
Twisted-Pair Cable for Switch (MDI-X) to Computer (MDI) Network Connection	B-3
Twisted-Pair Cable for Switch (MDI-X) to Hub or Switch (MDI-X) Network Connection	B-4
Twisted-Pair Cable Pin Assignments	B-5

C Safety and EMC Regulatory Statements

Safety Information	C-1
EMC Regulatory Statements	C-9

Index

Introducing the Switch 408

The HP ProCurve Switch 408 is a multiport switch that can be used to build high-performance switched workgroup networks. This switch is a store-and-forward device that offers low latency for high-speed networking.

HP ProCurve Switch 408 (HP J4097A)

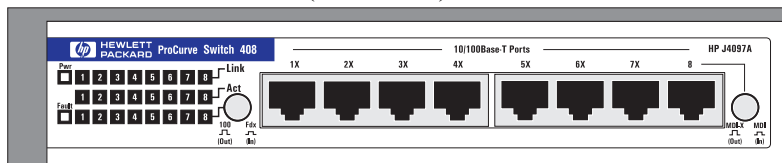

Throughout this manual, the name of this switch will be abbreviated as the Switch 408.

The Switch 408 has 8 auto-sensing 10/100Base-TX RJ-45 ports. With this switch you can build a switched network infrastructure by connecting it to hubs, other switches, or routers; or you can connect directly to computers, printers, and servers to provide dedicated bandwidth to those devices.

This chapter describes your Switch 408 including:

- Front and back of the switch
- Features
- Switch operation overview

Front of the Switch

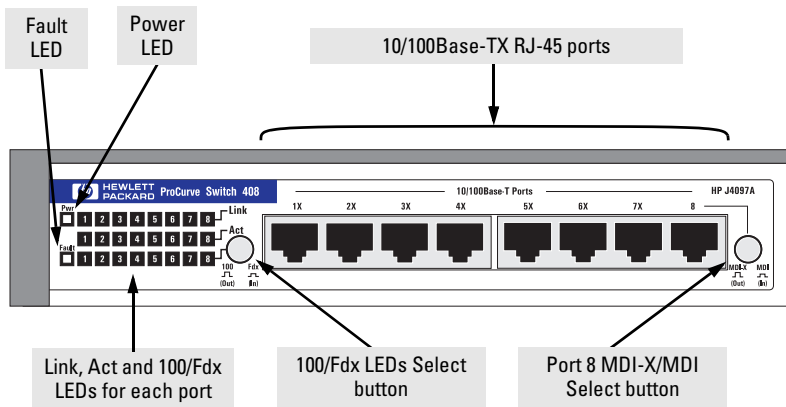

Network Ports

The switch has 8 auto-sensing 10/100Base-TX ports with RJ-45 connectors. All ports, except port 8, are wired as MDI-X ports. Port 8 can operate as either MDI-X or MDI, as controlled by the MDI-X/MDI Select button.

MDI-X/MDI Select Button

This button is used to select an MDI-X or MDI connection for port 8. Selecting MDI enables port 8 to be used as a cascade port for connecting to another switch or hub using straight-through cable. Selecting MDI-X makes port 8 operate the same as the other ports. They are used to connect computers, servers, printers and other end nodes using straight-through cables.

LEDs

Table 1-1. Switch LEDs

Switch LEDs	State	Meaning
Pwr (green)	On	The switch is receiving power.
	Off	The switch is NOT receiving power.
Fault (orange)	Off	The normal state; indicates that there are no fault conditions on the switch.
	On	The switch has a hardware failure, or has failed its self test. See chapter 3, "Troubleshooting" for more information.
Link (green – overlaid with the port number)	On	Indicates the port is operating correctly and receiving a link signal from the connected device.
	Off	One of these conditions exists: <ul style="list-style-type: none"> • no active network cable is connected to the port • the port is not receiving a link signal
Act (green – overlaid with the port number)	On/ Flickering	Indicates that there is network activity on the port.
100/Fdx (green – overlaid with the port number)	Displays whether the port is configured for full-duplex operation or 100 Mbps operation depending on the mode selected. See "100/Fdx Select Button" on the next page for more information.	
	100	Indicates that the 100/Fdx LEDs are lit for ports that are operating at 100 Mbps.
	Fdx	Indicates that the 100/Fdx LEDs are lit for ports that are in full-duplex mode.

100/Fdx Select Button

To optimize the amount of information that can be displayed for each of the switch ports without overwhelming you with LEDs, the Switch 408 uses a dual-function 100/Fdx LED for each port. The operation of this LED is controlled by the 100/Fdx Select button situated at the end of the row of LEDs. Press the button to select the desired display mode.

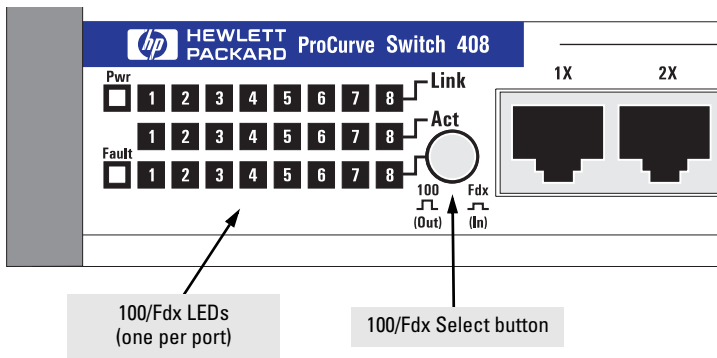

- If the 100/Fdx Select button is in the “out” position, the LEDs light for those ports that are operating at 100 Mbps.
- If the 100/Fdx Select button is in the “in” position, the LEDs light for those ports that are operating in full duplex.

Back of the Switch

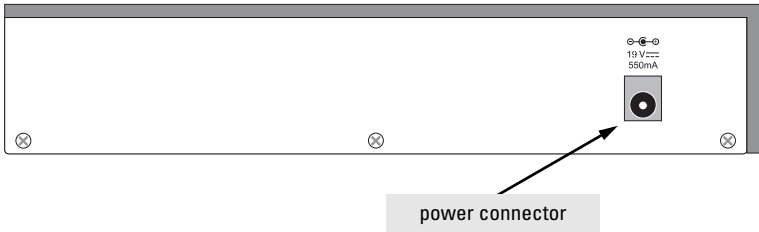

Power Connector

The Switch 408 does not have a power switch; it is powered on when the AC power adapter is plugged in to an active power source and to the switch.

Caution Use only the AC power adapter supplied with the switch. Use of other adapters, including those meant for other HP network products, may result in damage to the equipment.

Features

The features of the Switch 408 include:

- 8 auto-sensing 10/100Base-TX RJ-45 ports—all ports can sense the connection speed, 10 Mbps or 100 Mbps, and automatically operate at that speed
 - one port includes an MDI-X/MDI selection button
 - plug-and-play networking—all ports are enabled—just connect the network cables to active network devices and your switched network is operational
 - automatic learning of the hardware addresses in the switch's 8000-entry address forwarding table
 - auto-negotiation of half/full duplex on all ports
 - auto-negotiation of flow control for ports operating at full duplex
 - back-pressure flow control for ports operating at half duplex
-

Switch Operation Overview

Address Table Operation

Address Learning. As devices are connected to the switch ports, either directly or through hubs or other switches that are connected to the switch, the MAC addresses of those devices are learned automatically and stored in the Switch 408's 8000-entry address table. The switch also identifies the number of the port on which each address is learned so it knows the relative network location of each device.

Forwarding, Filtering, Flooding. When the switch receives a packet, it determines the destination address, and looks for the address in the address table. Based on the port location of that address, the switch then determines whether to forward, filter-out, or flood the packet.

- **forward** - if the destination address is on a different port than the one on which the packet was received, the packet is forwarded to the destination port and on to the destination device.
- **filter out** - if the destination address is on the same port as the one on which the packet was received, the packet is filtered out. The switch thereby isolates local traffic so the rest of the network connected to the switch does not use bandwidth dealing with unnecessary traffic.
- **flood** - whenever a new destination address is found in a packet received on a port, the destination address will not yet be in the switch's address table and the Switch 408 cannot know whether to forward or filter out the packet. In this case, it sends the packet to all the other switch ports. This is referred to as "flooding". When the destination device receives the packet, it replies, and the switch learns the new address from the reply packet. Then, all future packets destined for that address are forwarded or filtered out appropriately.

Network Moves and Changes. When devices are moved in the network, and become connected to a different switch port, the Switch 408 automatically recognizes the change and updates the address table with the new port locations of the devices. Communication with the connected devices is thereby automatically maintained.

Simultaneous Network Communications

As a part of the traffic isolation benefits provided by the Switch 408 address table operation, the switch enhances network performance because it can conduct multiple, simultaneous network connections. Instead of sharing the network bandwidth, as in connections to a hub, each connection has its own 10 Mbps or 100 Mbps bandwidth.

Installing the Switch 408

The HP ProCurve Switch 408 is easy to install. It comes with four rubber feet that can be attached so the switch can be securely located on any level surface (for example, a table or shelf). A mounting kit (5183-7210) is also available that provides a variety of mounting options including in a standard 19-inch EIA equipment rack or cabinet, on a wall, or under a horizontal surface. Contact your HP Networking products reseller to order the mounting kit.

This chapter shows you how to install your Switch 408.

Included Parts

The Switch 408 has the following components shipped with it:

- *HP ProCurve Switch 408 Installation Guide* (J4097-90001), this manual
- Customer Support/Warranty booklet
- Four rubber feet
- AC power adapter, one of the following:

Australia/New Zealand	0950-3269
China	0950-2809
Europe/Russia	0950-3268
Japan	0950-3267
South Korea	0950-3271
United Kingdom/Hong Kong	0950-3270
United States/Canada/Mexico/Taiwan/Brazil/Columbia	0950-3274

Installation Procedures

Summary

Follow these easy steps to install your switch. The rest of this chapter provides details on these steps.

1. **Prepare the installation site.** Make sure of the following:
 - the network cabling is the correct type and length. *See page 2-5.*
 - the network topology is correct. *See page 2-10.*
 - no devices connected to the switch have a fixed full-duplex configuration (they must be able to auto-negotiate the duplex mode or be fixed at half duplex). *See page 2-4.*

Please see page 2-3 for some installation precautions.

2. **Verify that the switch passes its self test.** This is a simple process of plugging the switch into a power source and observing that the LEDs on the switch's front panel show correct operation. *See page 2-7.*
3. **Mount the switch.** The Switch 408 can be mounted on any horizontal surface. The optional mounting kit (5183-7210) provides other options including mounting two switch units side-by-side in a standard 19-inch telco rack or equipment cabinet.
4. **Connect power to the switch.** Once the switch is mounted, plug in the AC power adapter. *See page 2-9.*
5. **Connect the network devices.** Using the appropriate network cables, connect computers, servers, printers and other peripherals, and other network devices including other switches, hubs, or routers to the switch ports. *See page 2-9.*

At this point, the switch is fully installed and your network should be up and running. See the rest of this chapter if you need more detailed information on any of these installation steps.

Installation Precautions:

Follow these precautions when installing your Switch 408.

- Cautions**
- Make sure that the power source circuits are properly grounded, then use the power adapter supplied with the switch to connect it to the power source.
 - When installing the switch, since the unit does not have an On/Off power switch, an AC power outlet must be located near the switch and should be easily accessible in case the switch needs to be powered off.
 - Make sure that the switch does not overload the power circuits, wiring, and over-current protection. To determine the possibility of overloading the supply circuits, add together the amperage ratings of all devices installed on the same circuit as the switch and compare the total with the rating limit for the circuit. The maximum amperage ratings are usually printed on the devices near the AC power connectors or power adapter connectors.
 - Do not install the switch in an environment where the operating ambient temperature might exceed 55°C (131°F).
 - Make sure the air flow around the sides of the switch is not restricted.
 - If you rack mount the Switch 408 (using the mounting kit, 5183-7210), the rack or cabinet should be adequately secured to prevent it from becoming unstable and/or falling over. Devices installed in a rack or cabinet should be mounted as low as possible, with the heaviest device at the bottom and progressively lighter devices installed above.

Continued on the next page.

- **Connect no devices that have a fixed full-duplex configuration.** Because the switch 408 complies with the IEEE 802.3u standard, if a device connected to the switch has a fixed configuration of full duplex, the device will not connect correctly to the switch. Make sure all devices connected to the Switch 408 are configured to auto negotiate, or are configured to connect at half duplex. For more information, see the “Basic Troubleshooting Tips” in chapter 3, “Troubleshooting”.
-

1. Prepare the Installation Site

- Cabling Infrastructure** - Make sure that the cabling infrastructure meets the necessary network specifications. For connections to end nodes (computers, servers, printers and other peripherals), use “straight-through” cables. For connections to hubs or other switches, use “crossover” cables, or use port 8 in MDI mode and a straight-through cable. See the following table for cable types and lengths, and see appendix B, “Cables and Connectors” for more information:

Table 2-1. Summary of Cable Types to Use with the Switch

Port Type	Cable Type	Length Limits
10Base-T	category 3, 4, or 5, 100-ohm unshielded twisted-pair (UTP) or shielded twisted-pair (STP)	category 3, 4, or 5 - 100 meters Note: Since the 10Base-T operation is through 10/100Base-TX ports, if you ever want to upgrade the ports to 100Base-T, it would be best to cable the ports initially with category 5 cable.
100Base-TX	category 5, 100-ohm UTP or STP	100 meters

- Installation Location** - Before installing the switch, plan its location and orientation relative to other devices and equipment. At the front of the switch, leave at least 7.6 cm (3 inches) of space for the twisted-pair cabling. At the back of the switch, leave at least 2.6 cm (1 inch) of space for the adapter’s power cord.

2. Verify the Switch Passes Its Self Test

Before mounting the switch in its network location, you should first check that it is working properly by plugging it into a power source and verifying that it passes its self test.

1. Connect the adapter's power cord to the power connector on the back of the switch, and then plug the AC power adapter into a nearby properly grounded electrical outlet.

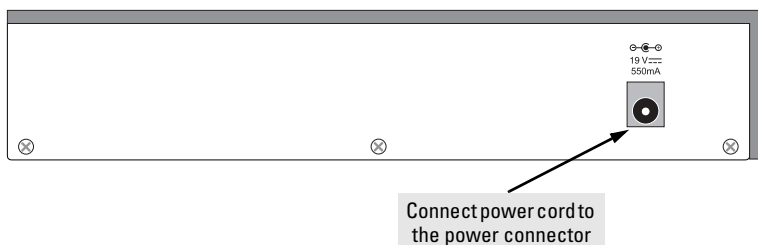

Note The Switch 408 does not have a power switch. It is powered on when the AC power adapter is connected to the switch and to a power source.

Caution Use only the AC power adapter supplied with the switch. Use of other adapters, including those meant for other HP network products, may result in damage to the equipment.

2. Check the LEDs on the switch. The LED behavior is described on the next page.

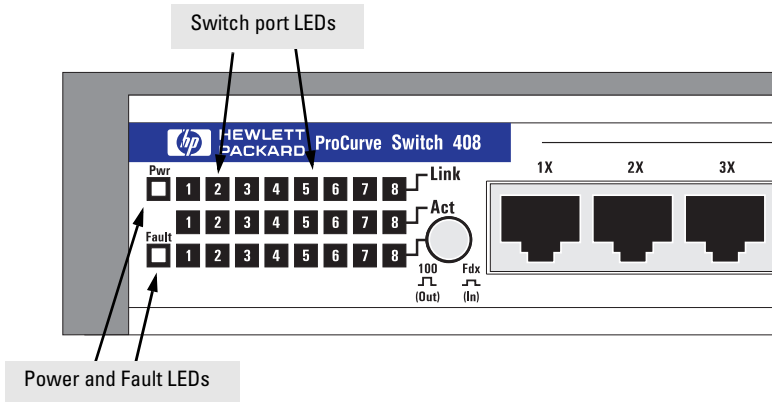

When the switch is powered on, it performs its diagnostic self test. The self test takes approximately 3 seconds to complete.

LED Behavior:

During the self test:

- All the switch and port LEDs are on.

When the self test completes successfully:

- The Power LED stays on and the Fault LED goes off.
- The port LEDs (Link, Act and 100/Fdx) go into their normal operational mode.

If the LED display is different than what is described above, especially if the Fault LED stays on for more than 5 seconds, the self test has not completed correctly. Refer to chapter 3, “Troubleshooting” for diagnostic help.

3. Mount the Switch

After you have verified that the switch passes its self test, you are ready to mount the switch in a stable location. The Switch 408 can be mounted in these ways:

- on a horizontal surface
- in a rack or cabinet, or on a wall (requires optional bracket kit)

Horizontal Surface Mounting

Attach the supplied rubber feet to the bottom of the switch, then place the switch on a table or other horizontal surface. Use a sturdy surface in an uncluttered area. You may want to secure the networking cables and switch power cord to the table legs or other part of the surface structure to help prevent people from tripping over the cords.

Note Make sure the air flow is not restricted around the sides of the switch.

Rack or Wall Mounting

Using the optional bracket kit (5183-7210), two Switch 408 units can be mounted together in any EIA-standard 19-inch telco rack or in an equipment cabinet such as a server cabinet. The switch brackets can also be used to mount the switch on a wall or under a horizontal surface. Installation instructions are included with the bracket kit.

Caution *For safe operation, please read the Installation Precautions on page 2-3 before mounting the switch.*

4. Connect the Switch to a Power Source

1. Plug the included AC power adapter into the switch's power connector and into a nearby AC power source.
2. Re-check the LEDs during self test. See “LED Behavior” on page 2-7.

5. Connect the Network Cables

Using the RJ-45 Connectors (10/100Base-TX ports)

To connect:

Push the RJ-45 plug into the RJ-45 jack until the tab on the plug clicks into place.

When power is on for the switch and for the connected device, the Link LED for the port should light to confirm a powered-on device (for example, an end node) is at the other end of the cable.

If the Link LED does *not* go on when the network cable is connected to the port, see “Diagnosing With the LEDs” in chapter 3, “Troubleshooting”.

To disconnect:

Press the small tab on the plug and pull the plug out of the jack.

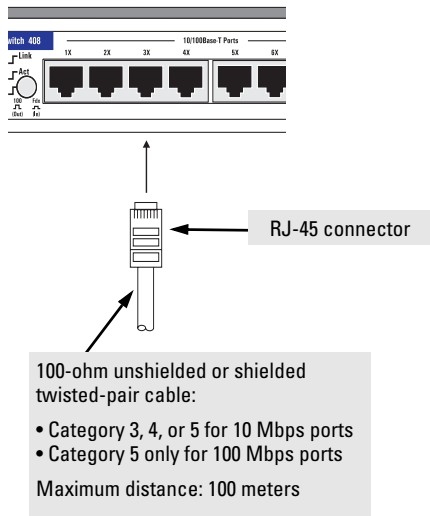

Sample Network Topologies

This section shows you two sample network topologies in which the Switch 408 is implemented.

Note Make sure the network into which you are installing the Switch 408 has a valid topology: there should be no loops in the data paths connected to the switch, and all twisted-pair connections should be no more than 100 meters.

As a Desktop Switch

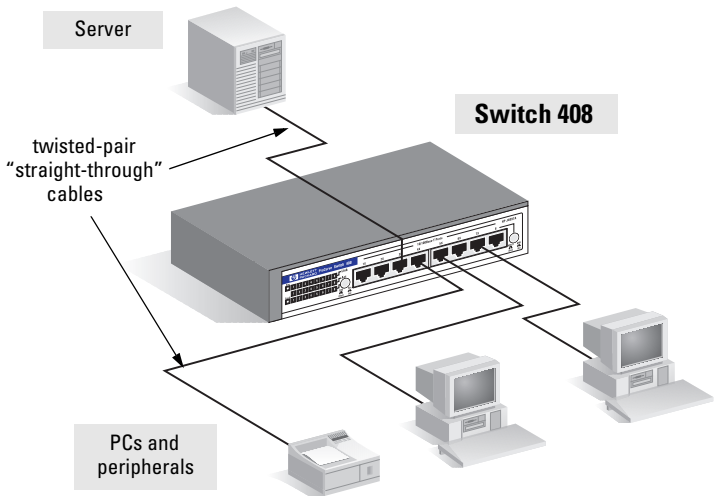

The Switch 408 is designed to be used primarily as a desktop switch to which end nodes, printers and other peripherals, and servers are directly connected, as shown in the above illustration. Notice that the end node devices are connected to the switch by “straight-through” twisted-pair cables.

As a Segment Switch

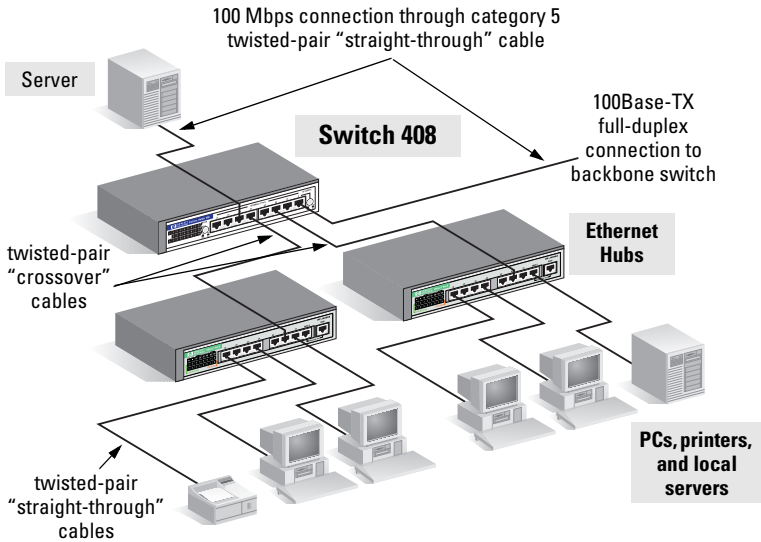

In general, the Switch 408 is designed to be used as a desktop switch, but it can also be used as a segment switch. That is, with its high performance and large address table, it can be used for interconnecting network segments—simply connect the network hubs that form those segments to the switch.

In the illustration above, two Ethernet hubs with PCs, printers, and local servers attached, are both connected to a Switch 408. The devices attached to the two hubs can now communicate with each other through the switch. They can also all communicate with the server that is connected to the switch. Make sure connections from servers to the Switch 408 are at 100 Mbps to minimize network congestion to the servers.

Installing the Switch 408

Sample Network Topologies

The connections between the switch and the MDI-X ports on the hubs are through “crossover” twisted-pair cables. If the hubs have MDI ports, you can connect to them through “straight-through” cables. The 100 Mbps connection to the server is through category 5 “straight-through” twisted-pair cable.

The switch, in turn, is connected to a backbone switch using “straight-through” twisted-pair cable connected to port 8 with the MDI-X/MDI Select button set to MDI. Now, all the devices on these network segments can access other network resources that are connected elsewhere on the network backbone.

Troubleshooting

This chapter describes how to troubleshoot your Switch 408 including the following:

- basic troubleshooting tips (page 3-1)
 - diagnosing with the LEDs (page 3-4)
 - hardware diagnostic tests (page 3-7)
 - HP Customer Support Services (page 3-8)
-

Basic Troubleshooting Tips

Most problems are caused by the following situations:

- **Incorrect switch-to-switch or switch-to-hub connections.** If you have connected your switch to another switch or a hub by using twisted-pair cable from an RJ-45 MDI-X connector on your switch to an MDI-X connector on the other switch or hub, you must use a **crossover cable**. If you have used a straight-through cable, the connection will not work. The Link LED for the port you are using will not come on when you connect the cable.

Most switch and hub ports are wired as MDI-X ports. LAN adapters in end nodes and peripherals are normally wired as MDI ports. Port 8 on the Switch 408, as well as some ports on other hubs and switches can also be set to operate as MDI ports. The simple rule is, when connecting the same-type ports together (for example MDI-X to MDI-X), use **crossover cable**; when connecting opposite-type ports together (for example MDI-X to

MDI), use **straight-through** cable. See appendix B, “Cables and Connectors” for pinouts and correct cable wiring for crossover and straight-through twisted-pair cables.

- **Connecting to devices with a fixed full-duplex configuration.** The Switch 408 ports are set to auto-negotiate the link characteristics. That is, when connecting to attached devices, the switch will operate in one of two ways to determine the link speed and the communication mode (half duplex or full duplex):
 - if the connected device is also set to auto negotiate, the switch will automatically negotiate both link speed and communication mode
 - if the connected device has a fixed configuration, for example (100 Mbps, and half or full duplex), the switch will automatically sense the link speed, but will default to a communication mode of half duplex

Because the Switch 408 behaves in this way (in compliance with the IEEE 802.3u standard), if a device connected to the switch has a fixed configuration at full duplex, the device will not connect correctly to the Switch 408. The result will be high error rates and high collision rates, and very inefficient communications between the switch and the device.

Make sure that all devices connected to the Switch 408 are configured to auto negotiate, or are configured to connect at half duplex (all hubs are configured this way, for example).

- **Faulty or loose cables.** Look for loose or obviously faulty connections. If they appear to be OK, make sure the connections are secure. If that does not correct the problem, try a different cable.
- **Non-standard cables.** Non-standard and miswired cables may cause numerous network collisions and other network problems, and can seriously impair network performance. Use a new correctly-wired cable or compare your cable to the cable in

appendix B, “Cables and Connectors” for pinouts and correct cable wiring. A category 5 cable tester is a recommended tool for every 100Base-T network installation.

- **Improper Network Topologies.** It is important to make sure you have a valid network topology. Common topology faults include excessive cable length and too many repeaters (hubs) between end nodes. If you have network problems after recent changes to the network, change back to the previous topology. If you no longer experience the problems, the new topology is probably at fault. Refer to the *Network Design Guide* for topology configuration guidelines. This guide can be found online at the HP World Wide Web site for networking products, <http://www.hp.com/go/procurve>. You can find it quickly by searching for “Network Design Guide”.

In addition, you should make sure that your network topology contains no data path loops. Between any two end nodes, there should be only one active cabling path at any time. Data path loops will cause broadcast storms that will severely impact your network performance.

Diagnosing With the LEDs

Table 3-1 shows LED patterns on the switch that indicate problem conditions.

1. Check in the table for the LED pattern that you see on your switch.
2. Refer to the corresponding diagnostic tip on the next few pages.

Table 3-1. LED Error Indicators

LED Pattern Indicating Problems			Diagnostic Tips
Power	Fault	Port Link	
Off with power cord plugged in	*	*	❶
On	Prolonged On	*	❷
On	Off	Off with cable connected	❸
* This LED is not important for the diagnosis.			

Diagnostic Tips:

Tip Number	Problem	Solution
1	The switch's power adapter is not plugged into an active AC power source, or the power adapter may have failed.	<ol style="list-style-type: none">1. Verify that the AC power adapter is plugged into an active power source and to the switch. Make sure these connections are snug.2. Try power cycling the switch by unplugging and plugging in the power.3. If the Power LED is still not on, verify that the AC power source works by plugging another device into the outlet. Or try plugging the switch into a different outlet. <p>If this condition persists, the switch's power adapter may have failed. Call your HP-authorized LAN dealer, or use the electronic support services from HP to get assistance. See the Customer Support/Warranty booklet for more information.</p>
2	A switch hardware failure was detected during self test.	<p>Try power cycling the switch. If the fault indication reoccurs, the switch may have failed. Call your HP-authorized LAN dealer, or use the electronic support services from HP to get assistance. See the Customer Support/Warranty card for more information.</p>

Tip Number	Problem	Solution
③	The network connection is not working properly.	<p>Try the following procedures:</p> <ul style="list-style-type: none">• For the indicated port, verify that both ends of the cabling, at the switch and the connected device, are secure.• Verify the connected device and switch are both powered <i>on</i> and operating correctly.• Verify that you have used the correct cable type for the connection.<ul style="list-style-type: none">- for twisted-pair connections, in general, for connecting from an MDI-X port to an MDI port, use “straight-through” cable; if connecting to MDI-X ports at both ends of a cable, use “crossover” cable.- if the connection is to port 8, make sure the position of the MDI-X/MDI Select button is correct for the type of connection. See page 1-2 for more information.• Verify that the connected devices comply with the IEEE 802.3 standard, including transmission of the Link signal. See “Testing Twisted-Pair Cabling” on page 3-7.• If the other procedures don’t resolve the problem, try using a different port or a different cable.

Hardware Diagnostic Tests

Testing the Switch by Resetting It

If you believe that the switch is not operating correctly, you can reset the switch to test its circuitry. To reset the switch, unplug and plug in the adapter's power cord (power cycling).

Power cycling causes the switch to perform its power-on self-test, and almost always will resolve any temporary operational problems.

Checking the Switch LEDs

The self-test passes if the Fault LED on the front of the switch goes off after approximately 3 seconds. If this LED stays on longer than 5 seconds, an error condition has been detected on the switch.

See “Diagnosing With the LEDs” on page 3-4 for information on interpreting the LED patterns.

Testing Twisted-Pair Cabling

If you think the cable should work but still isn't working, it may not be compatible with the IEEE 802.3 Type 10Base-T or 100Base-TX standards. The twisted-pair cables attached to the Switch 408 must be compatible with these standards. To verify that your cable is compatible with these standards, use a qualified cable test device.

HP also offers a wire testing service. Contact your HP-authorized LAN dealer or your local HP sales office for more information.

Testing End-to-End Network Communications

Both the switch and the cabling can be tested by running an end-to-end communications test – a test that sends known data from one network device to another through the switch. For example, if you have two PCs on the network, both connected to the switch, you can use a link-level packet test (link test) or Ping test to verify that the entire communication path between the two PCs is functioning correctly. See your LAN adapter documentation for more information on running a link test or Ping test.

HP Customer Support Services

If you are still having trouble with your switch, Hewlett-Packard offers support 24 hours a day, seven days a week through the use of a number of automated electronic services. See the Customer Support/Warranty booklet that came with your switch for information on how to use these services to get technical support. The HP networking products World Wide Web site, <http://www.hp.com/go/procurve> also provides up-to-date support information.

Additionally, your HP-authorized network reseller can provide you with assistance, both with services that they offer and with services offered by HP.

Specifications

Physical

Width:	19.9 cm (7.8 in)
Depth:	12.1 cm (4.8 in)
Height:	4.0 cm (1.6 in)
Weight :	0.72 kg (1.59 lbs)

Electrical

DC voltage:	19 volts
Maximum current:	0.55 A

Environmental

	Operating	Non-Operating
Temperature:	0°C to 55°C (32°F to 131°F)	-40°C to 70°C (-40°F to 158°F)
Relative humidity: (non-condensing)	10% to 90% at 40°C (104°F)	10% to 90% at 65°C (149°F)
Maximum altitude:	4.6 km (15,000 ft)	4.6 km (15,000 ft)

Connectors

- The 10/100 Mbps RJ-45 twisted-pair ports are compatible with the IEEE 802.3u 100Base-TX and IEEE 802.3 Type 10Base-T standards.

Safety

The Switch 408 complies with these safety standards:

- EN60950 / IEC 950
- CSA/NRTL (CSA 22.2 No. 950 & UL 1950)

Cables and Connectors

This appendix includes minimum pin-out information and specifications for cables that should be used with the Switch 408.

Note Incorrectly wired cabling is the most common cause of problems for LAN communications. HP recommends that you work with a qualified LAN cable installer for assistance with your cabling requirements.

Twisted-Pair Cable/Connector Pin-Outs

The RJ-45 ports (10 Mbps and 100 Mbps) on the Switch 408 are wired as MDI-X ports (port 8 can be set to MDI). The type of twisted-pair cable you connect to these ports (either “straight-through” or “crossover”) depends on the type of device at the other end of the cable.

***The rule is,** when connecting same-type ports together (for example MDI-X-to-MDI-X), use crossover cable; when connecting opposite-type ports together (for example MDI-X-to-MDI), use straight-through cable.*

Cables and Connectors

Twisted-Pair Cable/Connector Pin-Outs

These additional rules apply:

- All twisted-pair wires used must be twisted through the entire length of the cable. The wiring sequence must conform to the ANSI/TIA/EIA-568-B cable specification. See “Twisted-Pair Cable Pin Assignments” later in this appendix for a listing of the signals used on each pin.
- For 10 Mbps connections to the ports, you can use Category 3, 4, or 5 unshielded (UTP) or shielded (STP) twisted-pair cable, as supported by the IEEE 802.3 Type 10Base-T standard.
- For 100 Mbps connections to the ports, use 100-ohm Category 5 UTP or STP cable only, as supported by the IEEE 802.3u Type 100Base-TX standard.

Twisted-Pair Cable for Switch (MDI-X) to Computer (MDI) Network Connection

To connect PCs or other MDI network devices to these ports, use a “straight-through” cable.

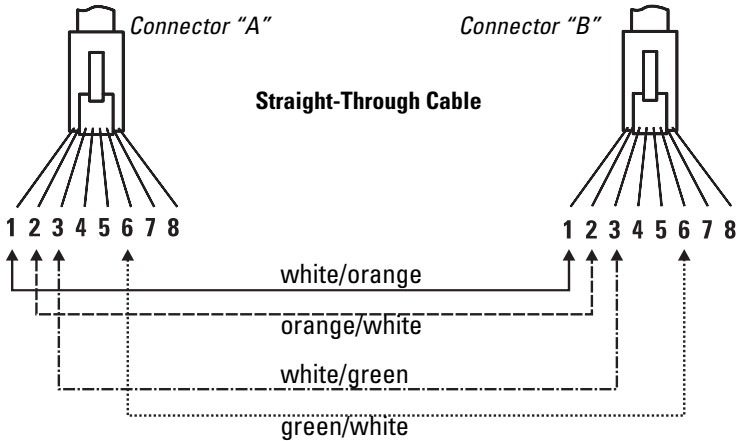

Note Pins 1 and 2 on connector “A” *must* be wired as a twisted pair to pins 1 and 2 on connector “B”.
Pins 3 and 6 on connector “A” *must* be wired as a twisted pair to pins 3 and 6 on connector “B”.

Pins 4, 5, 7, and 8 are not used in this application, although they may be wired in the cable.

Twisted-Pair Cable for Switch (MDI-X) to Hub or Switch (MDI-X) Network Connection

To connect hubs or switches or other MDI-X network devices to these ports, use a “crossover” cable.

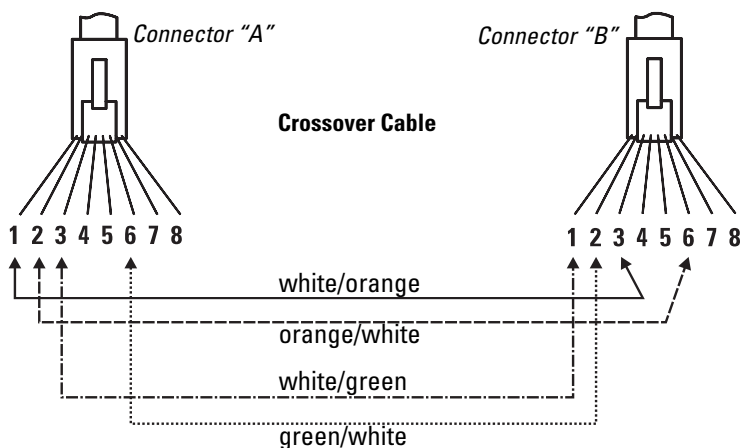

Note Pins 1 and 2 on connector “A” *must* be wired as a twisted pair to pins 3 and 6 on connector “B”.

Pins 3 and 6 on connector “A” *must* be wired as a twisted pair to pins 1 and 2 on connector “B”.

Pins 4, 5, 7, and 8 are not used in this application, although they may be wired in the cable.

Twisted-Pair Cable Pin Assignments

Twisted-Pair Straight-Through Cable

Switch End (MDI-X)		Computer, Transceiver, or Other MDI Port End	
Signal	Pins	Pins	Signal
receive +	1	1	transmit +
receive -	2	2	transmit -
transmit +	3	3	receive +
transmit -	6	6	receive -

Twisted-Pair Crossover Cable

Switch End (MDI-X)		Hub or Switch Port, or Other MDI-X Port End	
Signal	Pins	Pins	Signal
receive +	1	6	transmit -
receive -	2	3	transmit +
transmit +	3	2	receive -
transmit -	6	1	receive +

Safety and EMC Regulatory Statements

Safety Information



WARNING

Documentation reference symbol. If the product is marked with this symbol, refer to the product documentation to get more information about the product.

A **WARNING** in the manual denotes a hazard that can cause injury or death.

CAUTION

A **CAUTION** in the manual denotes a hazard that can damage equipment.

Do not proceed beyond a **WARNING** or **CAUTION** notice until you have understood the hazardous conditions and have taken appropriate steps.

Grounding

These are safety class I products and have protective earthing terminals. There must be an uninterruptible safety earth ground from the main power source to the product's input wiring terminals, power cord, or supplied power cord set. Whenever it is likely that the protection has been impaired, disconnect the power cord until the ground has been restored.

For LAN cable grounding:

- If your LAN covers an area served by more than one power distribution system, be sure their safety grounds are securely interconnected.

Safety and EMC Regulatory Statements

Safety Information

- LAN cables may occasionally be subject to hazardous transient voltages (such as lightning or disturbances in the electrical utilities power grid). Handle exposed metal components of the network with caution.

Servicing

There are no user-serviceable parts inside these products. Any servicing, adjustment, maintenance, or repair must be performed only by service-trained personnel.

These products do not have a power switch; they are powered on when the adapter's power cord is plugged in.

Informations concernant la sécurité



WARNING

Symbole de référence à la documentation. Si le produit est marqué de ce symbole, reportez-vous à la documentation du produit afin d'obtenir des informations plus détaillées.

Dans la documentation, un WARNING indique un danger susceptible d'entraîner des dommages corporels ou la mort.

CAUTION

Un texte de mise en garde intitulé CAUTION indique un danger susceptible de causer des dommages à l'équipement.

Ne continuez pas au-delà d'une rubrique WARNING ou CAUTION avant d'avoir bien compris les conditions présentant un danger et pris les mesures appropriées.

Cet appareil est un produit de classe I et possède une borne de mise à la terre. La source d'alimentation principale doit être munie d'une prise de terre de sécurité installée aux bornes du câblage d'entrée, sur le cordon d'alimentation ou le cordon de raccordement fourni avec le produit. Lorsque cette protection semble avoir été endommagée, débrancher le cordon d'alimentation jusqu'à ce que la mise à la terre ait été réparée.

Mise à la terre du câble de réseau local:

- si votre réseau local s'étend sur une zone desservie par plus d'un système de distribution de puissance, assurez-vous que les prises de terre de sécurité soient convenablement interconnectées.
- Les câbles de réseaux locaux peuvent occasionnellement être soumis à des surtensions transitoires dangereuses (telles que la foudre ou des perturbations dans le réseau d'alimentation public). Manipulez les composants métalliques du réseau avec précautions.

Aucune pièce contenue à l'intérieur de ce produit ne peut être réparée par l'utilisateur. Tout dépannage, réglage, entretien ou réparation devra être confié exclusivement à un personnel qualifié.

Cet appareil ne comporte pas de commutateur principal ; la mise sous tension est effectuée par branchement du cordon d'alimentation.

Hinweise zur Sicherheit



Symbol für Dokumentationsverweis. Wenn das Produkt mit diesem Symbol markiert ist, schlagen Sie bitte in der Produktdokumentation nach, um mehr Informationen über das Produkt zu erhalten.

WARNING

Eine WARNING in der Dokumentation symbolisiert eine Gefahr, die Verletzungen oder sogar Todesfälle verursachen kann.

CAUTION

CAUTION in der Dokumentation symbolisiert eine Gefahr, die das Gerät beschädigen kann.

Fahren Sie nach dem Hinweis WARNING oder CAUTION erst fort, nachdem Sie den Gefahrenzustand verstanden und die entsprechenden Maßnahmen ergriffen haben.

Dies ist ein Gerät der Sicherheitsklasse I und verfügt über einen schützenden Erdungsterminal. Der Betrieb des Geräts erfordert eine ununterbrochene Sicherheitserdung von der Hauptstromquelle zu den Geräteingabeterminals, den Netzkabeln oder dem mit Strom belieferten Netzkabelsatz voraus. Sobald Grund zur Annahme besteht, daß der Schutz beeinträchtigt worden ist, das Netzkabel aus der Wandsteckdose herausziehen, bis die Erdung wiederhergestellt ist.

Für LAN-Kabelerdung:

- Wenn Ihr LAN ein Gebiet umfaßt, das von mehr als einem Stromverteilungssystem beliefert wird, müssen Sie sich vergewissern, daß die Sicherheitserdungen fest untereinander verbunden sind.
- LAN-Kabel können gelegentlich gefährlichen Übergangsspannungen ausgesetzt werden (beispielsweise durch Blitz oder Störungen in dem Starkstromnetz des Elektrizitätswerks). Bei der Handhabung exponierter Metallbestandteile des Netzwerkes Vorsicht walten lassen.

Dieses Gerät enthält innen keine durch den Benutzer zu wartenden Teile. Wartungs-, Anpassungs-, Instandhaltungs- oder Reparaturarbeiten dürfen nur von geschultem Bedienungspersonal durchgeführt werden.

Dieses Gerät hat keinen Netzschalter; es wird beim Anschließen des Netzkabels eingeschaltet.

Considerazioni sulla sicurezza



WARNING

Simbolo di riferimento alla documentazione. Se il prodotto è contrassegnato da questo simbolo, fare riferimento alla documentazione sul prodotto per ulteriori informazioni su di esso.

La dicitura WARNING denota un pericolo che può causare lesioni o morte.

CAUTION

La dicitura CAUTION denota un pericolo che può danneggiare le attrezzature.

Non procedere oltre un avviso di WARNING o di CAUTION prima di aver compreso le condizioni di rischio e aver provveduto alle misure del caso.

Questo prodotto è omologato nella classe di sicurezza I ed ha un terminale protettivo di collegamento a terra. Dev'essere installato un collegamento a terra di sicurezza, non interrompibile che vada dalla fonte d'alimentazione principale ai terminali d'entrata, al cavo d'alimentazione oppure al set cavo d'alimentazione fornito con il prodotto. Ogniqualvolta vi sia probabilità di danneggiamento della protezione, disinserite il cavo d'alimentazione fino a quando il collegamento a terra non sia stato ripristinato.

Per la messa a terra dei cavi LAN:

- se la vostra LAN copre un'area servita da più di un sistema di distribuzione elettrica, accertatevi che i collegamenti a terra di sicurezza siano ben collegati fra loro;
- i cavi LAN possono occasionalmente andare soggetti a pericolose tensioni transitorie (ad esempio, provocate da lampi o disturbi nella griglia d'alimentazione della società elettrica); siate cauti nel toccare parti esposte in metallo della rete.

Nessun componente di questo prodotto può essere riparato dall'utente. Qualsiasi lavoro di riparazione, messa a punto, manutenzione o assistenza va effettuato esclusivamente da personale specializzato.

Questo apparato non possiede un commutatore principale; si mette scotto tensione all'inserirsi il cavo d'alimentazione.

Consideraciones sobre seguridad



WARNING

Símbolo de referencia a la documentación. Si el producto va marcado con este símbolo, consultar la documentación del producto a fin de obtener mayor información sobre el producto.

Una WARNING en la documentación señala un riesgo que podría resultar en lesiones o la muerte.

CAUTION

Una CAUTION en la documentación señala un riesgo que podría resultar en averías al equipo.

No proseguir después de un símbolo de WARNING o CAUTION hasta no haber entendido las condiciones peligrosas y haber tomado las medidas apropiadas.

Este aparato se enmarca dentro de la clase I de seguridad y se encuentra protegido por una borna de puesta a tierra. Es preciso que exista una puesta a tierra continua desde la toma de alimentación eléctrica hasta las bornas de los cables de entrada del aparato, el cable de alimentación o el juego de cable de alimentación suministrado. Si existe la probabilidad de que la protección a tierra haya sufrido desperfectos, desenchufar el cable de alimentación hasta haberse subsanado el problema.

Puesta a tierra del cable de la red local (LAN):

- Si la LAN abarca un área cuyo suministro eléctrico proviene de más de una red de distribución de electricidad, cerciorarse de que las puestas a tierra estén conectadas entre sí de modo seguro.
- Es posible que los cables de la LAN se vean sometidos de vez en cuando a voltajes momentáneos que entrañen peligro (rayos o alteraciones en la red de energía eléctrica). Manejar con precaución los componentes de metal de la LAN que estén al descubierto.

Este aparato no contiene pieza alguna susceptible de reparación por parte del usuario. Todas las reparaciones, ajustes o servicio de mantenimiento debe realizarlos solamente el técnico.

Este producto no tiene interruptor de potencia; se activa cuando se enchufa el cable de alimentación.

Safety Information (Japan)

安全性の考慮

安全記号



マニュアル参照記号。製品にこの記号がついている場合はマニュアルを参照し、注意事項等をご確認ください。

WARNING マニュアル中の「WARNING」は人身事故の原因となる危険を示します。

CAUTION マニュアル中の「CAUTION」は装置破損の原因となる危険を示します。

「WARNING」や「CAUTION」の項は飛ばさないで必ずお読みください。危険性に関する記載事項をよく読み、正しい手順に従った上で次の事項に進んでください。

これは安全性クラス I の製品で保護用接地端子を備えています。主電源から製品の入力配線端子、電源コード、または添付の電源コード・セットまでの間、切れ目のない安全接地が存在することが必要です。もしこの保護回路が損なわれたことが推測されるときは、接地が修復されるまで電源コードを外しておいてください。

LAN ケーブルの接地に関して:

- もし貴社の LAN が複数の配電システムにより電力を受けている領域をカバーしている場合には、それらのシステムの安全接地が確実に相互に結合されていることを確認してください。
- LAN ケーブルは時として危険な過度電圧（例えば雷や、配電設備の電力網での障害）にさらされることがあります。露出した金属部分の取扱いには十分な注意をはらってください。

本製品の内部にはユーザーが修理できる部品はありません。サービス、調整、保守および修理はサービス訓練を受けた専門家におまかせください。

本製品には電源スイッチがありません。電源コードを接続したとき電源入となります。

Safety Information (China)

HP 网络产品使用安全手册

使用须知

欢迎使用惠普网络产品，为了您及仪器的安全，请注意如下事项

1. 仪器要和地线相接。要使用有正确接地插头的电源线，使用中国国家规定的220V电源。
2. 避免高湿度和灰尘多的地方，否则易引起仪器内部部件的损坏。
3. 避免接近高温，避免接近直接热源，如直射阳光、暖气等其它发热体。
4. 不得有异物或液体落入机内，以免部件短路。
5. 不要将强磁体放置于仪器附近。

警告

为了防止火灾或触电事故，请不要将该机放置于淋雨或潮湿处。

安装

安装辅助管理模块请参见安装指南。

保修及技术支持

如果您按以上步骤正确使用但遇到了问题，或想了解其它产品性能，请按以下方式与我们联系。

如果是硬件故障：

1. 与售出单位或当地维修机构联系。
2. 惠普维修中心：
北京市海淀区知春路56号 中航科技大厦
邮政编码：100086
电话：010-62623888 转 6101

如果是软件问题：

1. 惠普技术支持中心热线电话：010-65053888 转 5858
2. 传真自动回复系统：010-65055280

EMC Regulatory Statements

U.S.A.

FCC Class A

This equipment has been tested and found to comply with the limits for a Class A digital device, pursuant to Part 15 of the FCC Rules. These limits are designed to provide reasonable protection against interference when the equipment is operated in a commercial environment. This equipment generates, uses, and can radiate radio frequency energy and, if not installed and used in accordance with the instruction manual, may cause interference to radio communications. Operation of this equipment in a residential area may cause interference in which case the user will be required to correct the interference at his own expense.

Canada

This product complies with Class A Canadian EMC requirements.

Australia/New Zealand



This product complies with Australia/New Zealand EMC Class A requirements.

Japan

VCCI Class A

この装置は、情報処理装置等電波障害自主規制協議会（VCCI）の基準に基づくクラスA情報技術装置です。この装置を家庭環境で使用すると電波妨害を引き起こすことがあります。この場合には使用者が適切な対策を講ずるよう要求されることがあります。

Korea

사용자 안내문 : A 급기기

이 기기는 업무용으로 전자파 적합등록을 받은 기기 이오니, 판매자 또는 사용자는 이점을 주의하시기 바라며, 만약 잘못 구입하셨을 때에는 구입한 곳에서 비업무용으로 교환하시기 바랍니다.

Taiwan

警告使用者：這是甲類的資訊產品，在居住的環境中使用時，可能會造成射頻干擾，在這種情況下，使用者會被要求採取某些適當的對策。

European Community

DECLARATION OF CONFORMITY

according to ISO/IEC Guide 22 and EN45014

Manufacturer's Name: Hewlett-Packard Company

Manufacturer's Address: 8000 Foothills Blvd.
Roseville, CA 95747-5502
U.S.A.

declares that the product:

Product Name: HP ProCurve Switch 408

Model Number: HP J4097A

conforms to the following Product Specifications:

Safety: EN60950 (1992) +A1, A2, A3, A4 / IEC 950 (1991) +A1, A2, A3, A4
EN60825-1 (1993) / IEC 825-1 (1993), Class 1
GB 4943 (1995)

EMC: EN 55022 (1994) +A1, prA2 / CISPR-22 (1993) +A1, A2 Class A
GB 9254 (1988)
EN50082-1 (1992)
IEC 61000-4-2 (1995), 4 kV CD, 8 kV AD
IEC 61000-4-3 (1995), 3 V/m
IEC 61000-4-4 (1995), 1 kV-(power line)
0.5 kV-(signal line)
IEC 61000-4-6 (1996), 3V

Supplementary Information:

The product herewith complies with the requirements of the Low Voltage Directive 73/23/EEC and the EMC Directive 89/336/EEC and carries the CE marking accordingly.

Tested with Hewlett-Packard Co. products only.

Roseville, April 14, 1999

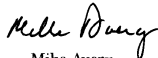

Mike Avery
Regulatory Engineering Manager

European Contact: Your local Hewlett-Packard Sales and Service Office or Hewlett-Packard GmbH, Department TRE, Herrenberger Strasse 130, D-71034 Boblingen (FAX:+49-7031-14-3143).

Index

Numerics

- 100/Fdx LEDs
 - description ... 1-3
 - selecting the display ... 1-4
- 100/Fdx Select button
 - location on switch ... 1-2
 - operation ... 1-4
- 100Base-TX
 - connections, length
 - limitations ... 2-5
 - ports, cables used with ... 2-5
- 10Base-T
 - connections, length
 - limitations ... 2-5
 - ports, cables used with ... 2-5

A

- Act LEDs
 - description ... 1-3
- address learning ... 1-6
- address table
 - automatic address learning ... 1-6
 - filtering out traffic ... 1-7
 - flooding traffic ... 1-7
 - forwarding traffic ... 1-7
 - moves and changes ... 1-7
 - operation ... 1-6

B

- back of switch
 - description ... 1-5
 - power connector ... 1-5
- bandwidth, how switch
 - enhances ... 1-8
- basic troubleshooting tips ... 3-1

buttons

- 100/Fdx Select button ... 1-4
- MDI-X/MDI button ... 1-2

C

- cabinet
 - mounting the switch in ... 2-8
- cables
 - 100Base-TX connections ... 2-5
 - 10Base-T connections ... 2-5
 - connecting cables to switch
 - ports ... 2-9
 - effects of non-standard
 - cables ... 3-2
 - incorrect network
 - connections ... 3-1
 - twisted-pair connector pin-outs ... B-1
- cables, twisted pair
 - category 3, 4, 5 ... B-2
 - crossover cable pin-out ... B-5
 - MDI-X to MDI connections ... B-3
 - MDI-X to MDI-X connections ... B-4
 - pin-outs ... B-5
 - straight-through cable pin-out ... B-5
 - switch-to-computer
 - connection ... B-3
 - switch-to-switch or hub
 - connection ... B-4
- connecting the switch to a power source ... 2-9
- connector specifications ... A-2
- crossover cable
 - pin-out ... B-5

D

- description
 - back of switch ... 1-5
 - front of switch ... 1-2
 - LEDs ... 1-3
- desktop switch
 - sample topology ... 2-10
- diagnostic tests ... 3-7
 - checking the LEDs ... 3-7
 - end-to-end connectivity ... 3-8
 - testing the switch only ... 3-7
 - testing twisted-pair cabling ... 3-7

E

- electrical specifications,
 - switch ... A-1
- EMC regulatory statements ... C-9
- environmental specifications,
 - switch ... A-1

F

- Fault LED ... 1-3
 - showing error conditions ... 3-4
- features
 - Switch 408 ... 1-6
- filtering out traffic ... 1-7
- flooding traffic ... 1-7
- forwarding traffic ... 1-7
- front of switch
 - 100/Fdx Select button ... 1-2, 1-4
 - LEDs ... 1-2
 - MDI-X/MDI Select button ... 1-2
 - network ports ... 1-2
- full-duplex connections,
 - troubleshooting ... 3-2

H

- horizontal surface, mounting switch
 - on ... 2-8

I

- included parts ... 2-1
- incorrect network connections ... 3-1
- installation
 - connecting the switch to a power source ... 2-9
 - mounting switch in rack or cabinet ... 2-8
 - mounting switch on a wall ... 2-8
 - on a horizontal surface ... 2-8
 - precautions ... 2-3
 - summary ... 2-2

L

- LEDs
 - 100/Fdx
 - description ... 1-3
 - selecting the display ... 1-4
- Act
 - description ... 1-3
 - behavior during self test ... 2-7
 - checking during
 - troubleshooting ... 3-7
 - descriptions of ... 1-3
 - error indications ... 3-4
 - Fault ... 1-3
 - showing error conditions ... 3-4
 - Link ... 1-3
 - location on switch ... 1-2
 - on switch ... 1-3
 - Power ... 1-3
 - behavior during self test ... 2-7

- length limitations
 - 100Base-TX connections ... 2-5
 - 10Base-T connections ... 2-5
- Link LEDs ... 1-3

M

- MDI-X to MDI network cable ... B-3
- MDI-X to MDI-X network cable ... B-4
- MDI-X/MDI button
 - description ... 1-2
 - location on switch ... 1-2
- mounting the switch
 - in a rack or cabinet ... 2-8
 - on a horizontal surface ... 2-8
 - on a wall ... 2-8
- moves and addresses
 - effect on address table ... 1-7

N

- network cables
 - 100Base-TX connections ... 2-5
 - 10Base-T connections ... 2-5
 - incorrect connections ... 3-1
 - twisted-pair connector pin-outs ... B-1
- network devices
 - connecting to the switch ... 2-9
- network ports
 - connecting to ... 2-9
 - location on switch ... 1-2
 - standards compliance ... A-2
 - types of ... 1-2
- non-standard network cables,
 - effects ... 3-2

P

- parts, included with the switch ... 2-1
- physical specifications, switch ... A-1
- pin-outs
 - twisted-pair cables ... B-1
- port LEDs
 - 100/Fdx ... 1-3
 - Act ... 1-3
 - Link ... 1-3
- ports
 - 10/100Base-TX, location on switch ... 1-2
 - network connections ... 2-9
- power connector ... 1-5
- Power LED ... 1-3
 - behavior during self test ... 2-7
- power source
 - connecting the switch to ... 2-9
- precautions
 - mounting the switch ... 2-3
 - power requirements ... 2-3

R

- rack
 - mounting precautions ... 2-3
 - mounting the switch in ... 2-8
- regulatory statements ... C-9
- resetting the switch
 - troubleshooting procedure ... 3-7

S

- safety specifications ... A-2
- segment switch
 - sample topology ... 2-11
- selecting the 100/Fdx LED display ... 1-4

- self test
 - LED behavior during ... 2-7
- specifications
 - connectors ... A-2
 - electrical ... A-1
 - environmental ... A-1
 - physical ... A-1
 - safety ... A-2
- straight-through cable
 - pin-out ... B-5
- summary of switch installation ... 2-2
- switch
 - connecting to a power
 - source ... 2-9
 - electrical specifications ... A-1
 - environmental
 - specifications ... A-1
 - features ... 1-6
 - front panel description ... 1-2
 - included parts ... 2-1
 - LED descriptions ... 1-3
 - mounting in a rack or cabinet ... 2-8
 - mounting on horizontal
 - surface ... 2-8
 - physical specifications ... A-1
- switch operation
 - address table ... 1-6
 - description ... 1-6
 - filtering out traffic ... 1-7
 - flooding traffic ... 1-7
 - forwarding traffic ... 1-7
 - network moves and changes ... 1-7
 - simultaneous network
 - communications ... 1-8
 - verifying after installation ... 2-6

T

- testing
 - checking the LEDs ... 3-7
 - diagnostic tests ... 3-7
 - end-to-end communications ... 3-8
 - switch operation ... 3-7
 - twisted-pair cabling ... 3-7
- tips for troubleshooting ... 3-1
- topologies
 - effects of improper topology ... 3-3
 - samples of ... 2-10
- troubleshooting
 - basic tips ... 3-1
 - checking the LEDs ... 3-7
 - common network problems ... 3-1
 - diagnostic tests ... 3-7
 - effects of improper topology ... 3-3
 - effects of non-standard
 - cables ... 3-2
 - fixed full-duplex connections ... 3-2
 - incorrect network
 - connections ... 3-1
 - testing end-to-end
 - communications ... 3-8
 - testing the switch ... 3-7
 - testing the twisted-pair
 - cables ... 3-7
- twisted-pair cable
 - crossover cable pin-out ... B-5
 - pin-outs ... B-1, B-5
 - straight-through cable pin-out ... B-5
 - switch-to-computer
 - connection ... B-3
 - switch-to-switch or hub
 - connection ... B-4
 - testing ... 3-7



Technical information in this document is subject to change without notice.

©Copyright Hewlett-Packard Company 1999. All rights reserved. Reproduction, adaptation, or translation without prior written permission is prohibited except as allowed under the copyright laws.

Printed in Taiwan 4/99

Manual Part Number
J4097-90001



150033-102 R01