HP AdvanceStack 10BT Management Module

Installation and Reference Guide

© Copyright 1996 Hewlett-Packard Company
All Rights Reserved.

This document contains information which is protected by copyright. Reproduction, adaptation, or translation without prior permission is prohibited, except as allowed under the copyright laws.

Publication Number

J3210-90001
Edition 1
August 1996

Applicable Product

HP J3210A Management Module
HP J3212A Switch Module
HP J3200A Switching Hub-12R
HP J3202A Switching Hub-24R
HP J3204A Switching Hub-24T

Disclaimer

The information contained in this document is subject to change without notice.

HEWLETT-PACKARD COMPANY MAKES NO WARRANTY OF ANY KIND WITH REGARD TO THIS MATERIAL, INCLUDING, BUT NOT LIMITED TO, THE IMPLIED WARRANTIES OF MERCHANTABILITY AND FITNESS FOR A PARTICULAR PURPOSE. Hewlett-Packard shall not be liable for errors contained herein or for incidental or consequential damages in connection with the furnishing, performance, or use of this material.

Hewlett-Packard assumes no responsibility for the use or reliability of its software on equipment that is not furnished by Hewlett-Packard.

Warranty

A copy of the specific warranty terms applicable to your Hewlett-Packard products and replacement parts can be obtained from your HP Sales and Service Office or authorized dealer.

Contents

1 Installing the Management Module

<u>Installation Steps</u>	1-1
<u>Removing the Module</u>	1-6

2 Management Module Features

<u>Port Switching</u>	2-2
<u>Increasing Throughput with HP Switching Hubs</u>	2-2
<u>Communication Between Hubs When Users Are on</u> <u>the Same Segment</u>	2-3
<u>Communication Between Segments</u>	2-4
<u>Displaying Segment Information</u>	2-4
<u>Example of using the Segment Display Button</u>	2-5
<u>Management</u>	2-6
<u>Configuring, Diagnosing, and Troubleshooting the</u> <u>Network with Management</u>	2-6
<u>Resetting the Stack with Management</u>	2-7
<u>Redundant Management in a Stack</u>	2-7
<u>Advanced Management: RMON and EASE Support</u>	2-8
<u>RMON</u>	2-8
<u>EASE</u>	2-8

3 Configuring the Switching Hubs in Software

<u>Two Network Management Interfaces</u>	3-1
<u>ASCII Console Features</u>	3-1
<u>HP AdvanceStack Assistant Features</u>	3-2
<u>Connecting to the ASCII Console</u>	3-3
<u>Directly, Using A Serial Cable and a Terminal</u>	3-3
<u>Remotely, Using Telnet</u>	3-4
<u>Remotely, Using a Modem and a Terminal</u>	3-5

<u>Using the Console</u>	3-6
Port Counters	3-8
Segment Counters	3-9
4 <u>Removing A Hub From a Stack</u>	
<u>Number of Hubs Allowed In the Stack</u>	4-2
<u>Reinserting a Hub into a Stack</u>	4-3
Effect on Network Connectivity When a Hub is Removed from a Stack	4-3
5 <u>Troubleshooting</u>	
<u>IP Configuration Errors</u>	5-3
<u>Diagnostic Tests</u>	5-4
Testing the Hub Only	5-4
Possible Failure of a Redundant Management Module	5-4
Testing the Hub's Ports and the Links	5-5
Clearing a Password for the ASCII Console	5-6
<u>HP Customer Support Services</u>	5-7
A <u>Cables and Connectors</u>	
<u>Recommended Cables</u>	A-1
<u>RS-232 Connector and Cable Pin-Outs</u>	A-2
A Minimum Cable Pinout for ASCII Console Connection	A-3
RS-232 Modem Cable	A-3
B <u>Specifications</u>	
C <u>Modem Configuration</u>	

D Network Addressing

<u>Communication Between the Hub and Network Management Station</u>	D-1
<u>IPX Addressing for Novell Netware</u>	D-2
<u>IP Addresses for IP and Non-IP Networks</u>	D-3
Setting the IP Address for a Hub	D-3
<u>Using Bootp</u>	D-4
The Bootp Process	D-4
Bootp Table File Entries	D-4

E Backup Links

<u>Examples of Backup Links</u>	E-1
How the Backup Function Works	E-2
<u>Configuring a Backup Link</u>	E-4
Configuration/Installation Sequence	E-5
<u>Identifying the Backup Link</u>	E-5
<u>Indications of Backup Link Activation</u>	E-6
<u>Reactivating the Primary Link</u>	E-6

Index

HP Customer Support Services

How to get the latest software/agent firmware

You can download the following:

HP Management Module firmware: j3210a.exe

from the HP BBS, HP FTP Library Service, CompuServe, and the World Wide Web.

After you download the file, **extract** the file by typing: *filename /x*. For example, j3210a.exe /x

HP BBS

Set your modem to no parity, eight bits, 1 stop bit, set speed up to 14400 bps, and with your telecommunication program (e.g., Windows Terminal) dial (208) 344-1691 to get the latest software for your HP networking product.

HP FTP Library Service

1. FTP to Internet IP Address — ftp ftp.hp.com.
2. Log in as anonymous and press at the password prompt.
3. Enter bin to set the transfer type.
4. Enter cd /pub/networking/software.
5. Enter get *filename* to transfer the file to your computer, then quit.

CompuServe

1. Login to CompuServe.
2. Go to the “hp” service.
3. Select “HP Systems, Disks, Tapes, etc.”
4. Select “Networking Products” library.
5. Download *filename* then quit.

World Wide Web

http://www.hp.com/go/network_city

Select the “Support” section.

From this web site, you can also download information on the HP Switching Hubs and HP AdvanceStack Assistant. If you have a growing network, download the Designing HP AdvanceStack Workgroup Networks Guide or call 1-800-752-0900 to receive a copy through mail.

(over for more services)



Obtain the latest console code (j3210a.exe) from

HP FTP Library: ftp ftp.hp.com

World Wide Web: http://www.hp.com/go/network_city

HP BBS: (208) 344-1691

(over)



HP FIRST Fax Retrieval Service

HP FIRST is an automated fax retrieval service that is available 24 hours a day, seven days a week. HP FIRST provides information on the following topics:

- Product information
- Troubleshooting instructions
- Technical reviews and articles
- Configuration information

To access HP FIRST, dial one of the following phone numbers:

Location	Phone Number
U.S. and Canada Only	Dial 1 (800) 333-1917 with your fax machine or touch-tone phone and press 1.
Outside the U.S. and Canada	Dial 1 (208) 344-4809 from your fax machine and press 9. To receive a list of currently available documents, enter document number 19941. The information you requested will be sent to you by return fax.

HP Network Phone-In Support (NPS)

In addition to the above services, the HP Network Phone-In Support (NPS) service provides expert technical assistance for U.S.A. customers through an NPS contract or at an hourly rate (1-800-790-5544) Monday through Friday, 5 am to 6 pm, Pacific Time. You may also contact your HP Authorized Reseller or the nearest HP Sales and Support Office to purchase an NPS contract.



CompuServe: Go to the "hp" service.
Select HP systems, etc.
Select Networking Products.
Download the file.

Network Phone-In Support (hourly): 1-800-790-5544

Installing the Management Module

Installation Steps

The HP J3210A AdvanceStack 10BT Management Module is installed into the front of the HP AdvanceStack Switching Hub. Hereafter, the module will be called the Management Module.

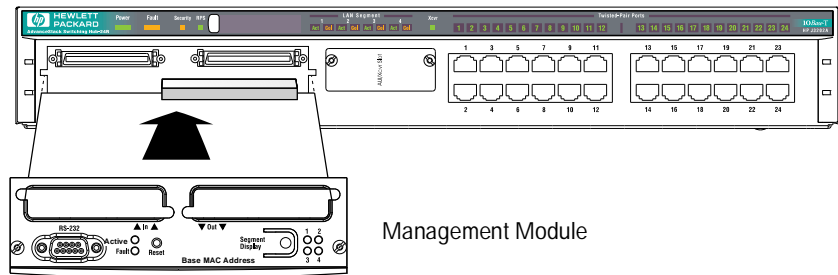

Follow these steps to install the module:

1. Verify you have these parts:
 - Management Module
 - HP AdvanceStack Assistant for Windows CD-ROM kit
 - This manual-*HP AdvanceStack Management Module Installation and Reference Guide (J3210-90001)*
 - Serial cable (5182-4794)
 - Optional: 8 MB SIMM memory upgrade-HP D2691A. The SIMM memory upgrade enables the five remaining RMON groups. It can be purchased from your HP-authorized dealer or reseller.

Caution

2. Static electricity can severely damage the sensitive electronic components on the module. When installing the module in your hub or when inserting a SIMM onto the module, follow these procedures to avoid damage from static electricity:
 - Handle the module or SIMM by its edges and avoid touching the components and the circuitry on the board.
 - Equalize any static charge difference between your body and the hub by wearing a wrist static-protector strap and attaching it to the hub's metal body, or by frequently touching the hub's metal body while you are installing the module.
3. Before installing the Management Module, unplug your hub or stack of hubs from the power source.
4. If there is an Extender Cable, remove the Extender Cable from the slots marked IN and OUT.
5. If you have bought the memory upgrade package in order to support five additional RMON groups, then you need to install the SIMM before putting the module in the hub. The SIMM can be installed in one orientation only. Follow the instructions in the illustration below to install the SIMM correctly:

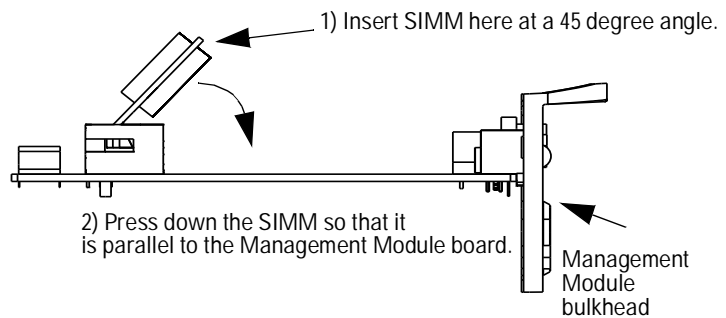

6. Unscrew the two captured screws holding the cover plate to the hub's Management Slot and remove the cover. Note that the screws will release outward when unscrewed far enough. Do not unscrew them completely from the cover plate.

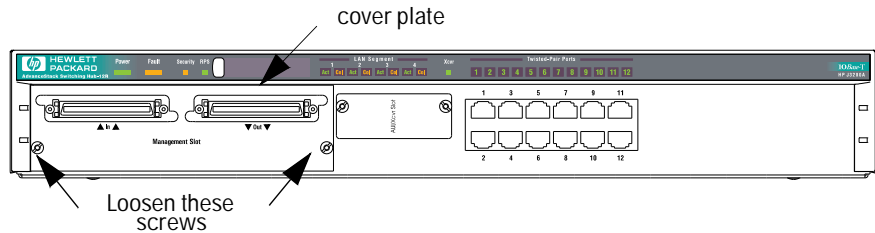

7. Insert the Management Module into the hub. Leading with the hub connector edge, line up the sides of the module with the rails on the sides of the hub's slot. Then push the module into the slot until it is firmly seated in the connector in the back of the slot.

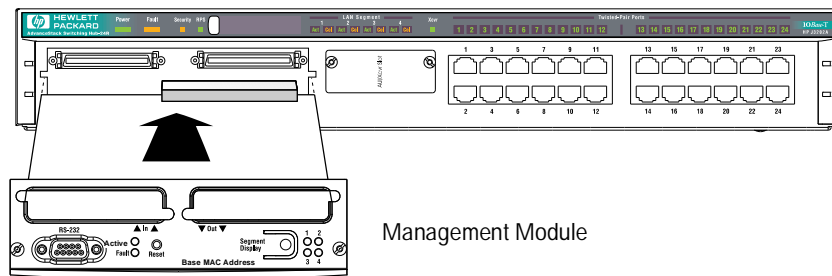

8. Tighten the two screws that hold the module in place. *Be careful not to overtighten the screws.*
9. If you are installing a second Management Module for redundancy, repeat steps 1-8.
10. Reconnect the Extender Cable if there is one. The hub at the top of the stack should only have a cable connected in the OUT port so that stack order is accurately displayed in HP AdvanceStack Assistant and the ASCII console.

11. Turn on the power to the hub with the Management Module and then provide power to the rest of the hubs in the stack. Provide power by plugging in the power cord to the hub. During power-on, the following occurs:

At Power On	Hub begins power-on self test followed by the module's self test. Ports are temporarily disabled until the Management Module configures the ports.
During Self-Test	All Module LEDs are on. The hub and module self-tests require about 10 seconds total. If a SIMM is added, the self-test requires 30 seconds' time. For every hub in the stack add about 2 seconds to the self-test time. A stack of eight hubs will take about 20 seconds to complete.
After Self-Test	All of the module LEDs turn off except the Active LED for the primary module. The redundant module will have no LEDs on.

If the Fault LED is on, refer to chapter 5, "Troubleshooting" in this guide.

You have now completed installation and verification of the module. The hardware features of this module are as follows:

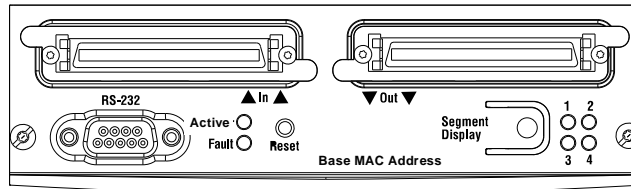

LED or Button	Status	Description
Active	ON	Specifies this module is the primary module if a second module is in the stack.
	OFF	This module is the redundant module in the stack and will take over if the primary module fails.
Fault	ON	The Module has experienced a failure, possibly because of incorrect installation of the SIMM module or incorrect installation into the hub.
Reset	-	Resets all hubs and modules in the stack.
Segment Display	-	Lights the Segment number and Port LEDs to show which nodes are on a segment. Segment number is lit. (If you hold this button down for eight seconds, all Segment numbers are lit on the Management Module and you will clear the password to the ASCII console.)
1, 2, 3, 4	ON	Number of segment being displayed.

To configure IP/IPX for the Management Module, see Appendix D, “Network Addressing”.

Removing the Module

The module is removed from the hub by reversing the installation steps described earlier in this document. To remove the module, follow these steps:

1. Remove power from the hub by unplugging the power cord.
2. Remove the Extender Cable(s).
3. Unscrew the two captured screws holding the module.
4. Pull the module out of the slot.
5. Replace the slot with the Management Slot cover plate and reinstall the Extender Cable(s). You are finished when your hubs appear like this illustration:

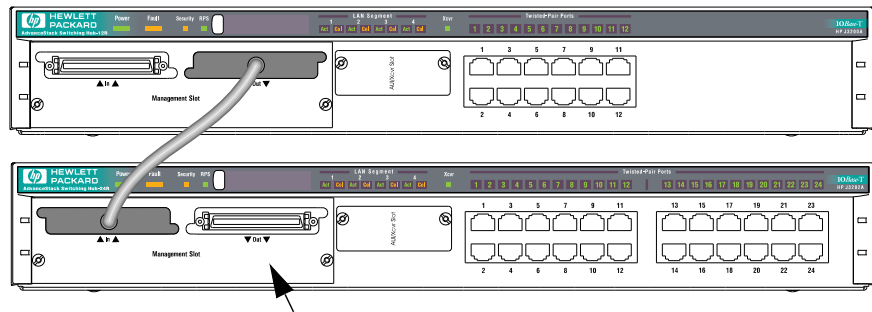

Cover plate

Warning

Replace the cover plate over the slot using the two screws that hold it in place. Be careful not to overtighten the screws. When using the hub, the cover plate must always be installed. This is required not only for safety, but also to ensure proper hub cooling.

Management Module Features

With the Management Module, you can now address the problems of a busy and growing network with the following features:

- **Port Switching.** Gives you the ability to move ports onto one of four network segments to increase network throughput
- **Management.** Ability to configure, diagnose and troubleshoot network problems using two software interfaces: HP AdvanceStack Assistant for graphical in-band network connections; and a text-based application, called the ASCII console, for out-of-band management port access.
- **Redundant Management.** If one management module fails, another one in the stack takes over. This means no network downtime.
- **Advanced SNMP Management.** Using RMON and EASE to diagnose network problems to help optimize network performance.

Only one Management Module is needed to manage and configure an entire stack of hubs. A stack has a maximum of eight hubs. These features are described in this chapter.

Port Switching

Within each Switching Hub, there are four distinct network segments, as if there were actually four hubs in one. These segments run through an entire stack of hubs through the Extender Cable. Port switching is the ability to move ports from one segment to another through software rather than physically moving cables in the wiring closet.

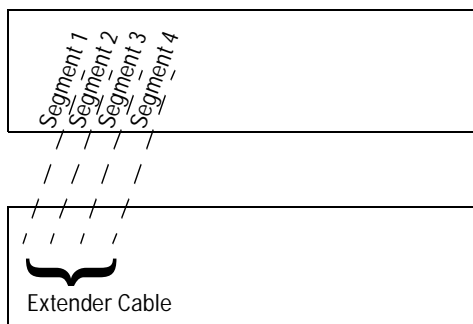

Note

In previous hub documentation, HP has used the term “segmentation” and “auto-segmentation” to mean partitioning. In this manual and future manuals, segmentation means dividing a hub into different collision domains and partitioning means that a port has been temporarily disabled because of excessive collisions.

Increasing Throughput with HP Switching Hubs

HP Switching Hubs have four segments (or collision domains) which you can move ports to by using the ASCII console or HP AdvanceStack Assistant. Every user is placed on segment 1 by default. If the network becomes congested and network performance suffers, the Management Module can be used to move ports onto the three other segments in the stack. (Note that if you have an HP Switch Module in the stack, it can automatically distribute users across all segments on power up.)

Communication Between Hubs When Users Are on the Same Segment

Users can communicate with each other on the *same* segment in the stack through the Extender Cable. The following example shows two hubs with users on segment 2.

Segments Example

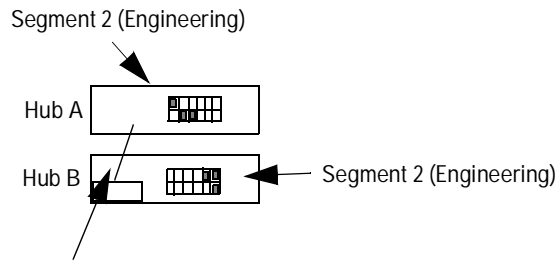

Users on Hub A and Hub B can talk to each other because they are on the same segment. Notice that the users can be connected to any hub and to any port, contiguous or noncontiguous.

Communication Between Segments

Communication *between* the segments can be achieved through:

- multiple LAN adapters in the server
- switch
- router

For example, add an external switch or Switch Module to your stack if you want users (for example) on segment 2 to talk to users on segments 1 and 3.

Communicating Between Segments

Segment 1 (Finance): 1, 4, 5

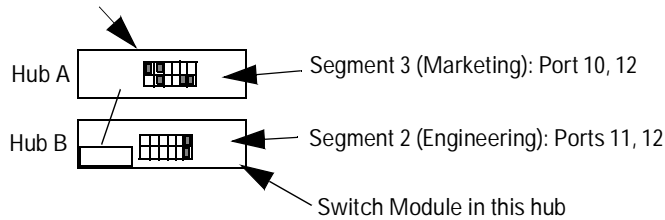

All users connected to these hubs communicate across the switch.

Displaying Segment Information

After users are distributed across segments, you can display segment information in software or by using a button on the Management Module called the Segment Display button. This button displays which ports are on the four connected segments. The Segment Display button changes the port LEDs to reflect which nodes are on each segment instead of status.

Port LEDs on Segment 1, 2, 3, and 4 turn on sequentially each time you press the Segment Display Button.

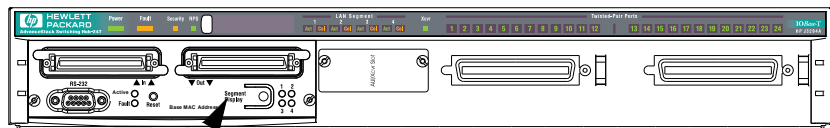

Segment Display button

Note

If you have not moved ports to segments 2-4, then port LEDs will be lit after you press the Segment Display button once. This is because all ports are on segment 1.

Example of using the Segment Display Button

To discover which nodes are on segment 1, press the Segment Display button once. The “1” LED on the Management Module is lit and the ports on segment one are lit. Press the Segment Display button again and the ports on segment two are lit, and so forth. After 60 seconds, the port LEDs go back to displaying link status information rather than segment information. If you press the Segment Display button a fifth time, the LEDs will also go back to displaying link status information also.

Example: Network administrator wants to know which ports are on Segment 2. Ports 1, 4-8 are now lit.

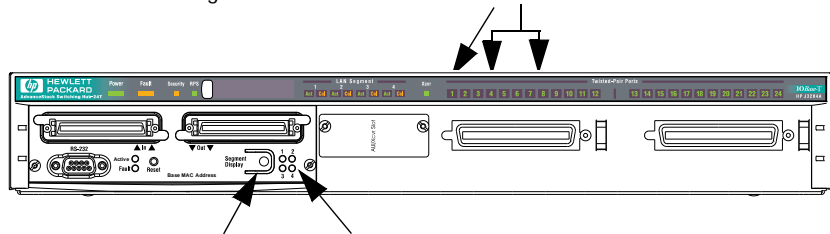

Press Segment Display button twice. Segment 2 LED is lit.

Remember that if you have two Management Modules installed in the stack, press the Segment Display button on the active Management Module, rather than the redundant one.

Management

When you install the Management Module, it has four MAC addresses. One MAC address is for each of the four segments. The Management Module shows the base MAC address for segment 1. Add one to this address to get the MAC address for segment 2, add one more for segment 3, etc. The four MAC addresses are listed in HP AdvanceStack Assistant and the ASCII console's General Status option:

```
General Status
System Name:   Marketing
System Contact: Susan
System Location: 3rd floor
Download Version: ROM A.01.04. EEPROM A.01.15.
System Up Time: 0 Days, 16:34:32 (HH:MM:SS)

Device Fault:  None Detected
Device with Active Management Module: finance hub
Type: HP J3200A AdvanceStack 10BT Switching Hub-12R
Stack Position: 1
MAC Addresses
Segment 1: 080009-ccd5d8  Segment 2: 080009-ccd5d9
Segment 3: 080009-ccd5da  Segment 4: 080009-ccd5db

SNMP Module Security Information
No violation
Change any of the system information? (Y/[N]):
```

Each hub does not need a MAC address because the MAC addresses are for the segments in the entire stack of hubs.

Configuring, Diagnosing, and Troubleshooting the Network with Management

Before the Management Module was installed, there was no software interface to determine why ports were disabled, why collisions and activity rates were high, and why a user could not communicate with a device.

With the Management Module's two included software interfaces, you can find out which nodes are "top talkers" and are causing congestion on the network, move some of those users to another segment, and monitor traffic in a graphical format. These software features are described in chapter 3.

Resetting the Stack with Management

If you install an optional Management Module, its reset button resets the entire stack of hubs. The hubs are reconfigured and counters are reset to zero. This can also be done through the ASCII console or HP AdvanceStack Assistant.

From the ASCII console, you can also change the hub back to its default settings. The default settings are all ports enabled, security violations cleared, and all ports are placed back on segment 1.

The rest of the management features are described in chapter 3.

Redundant Management in a Stack

Two Management Modules in a stack provide you with redundant management so that if one module fails, the other module will take over. To identify the hub with the Management Module acting as primary, the Active LED is lit on the Management Module. After you install the second Management Module, you should specify which one is primary through the ASCII console or through HP AdvanceStack Assistant. (If you do not select a module, the module with the lowest MAC address is active.)

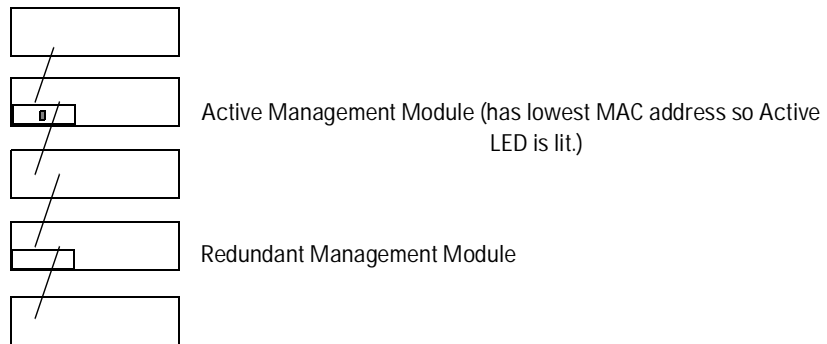

If the second Management Module takes over because the first one failed, see chapter 5, “Troubleshooting.”

Advanced Management: RMON and EASE Support

The Management Module supports RMON (Remote Monitoring) and EASE on all four segments. This allows for troubleshooting and optimizing of your network.

RMON

The following RMON groups are supported across all four segments and the Switch Module simultaneously:

- Ethernet statistics
- alarm
- history
- event

You can access the Ethernet statistics, alarm, and event groups from HP AdvanceStack Assistant.

By adding an optional memory upgrade (HP D2691A), you enable the remaining 5 RMON groups. The other 5 groups are Host, Host Top N, Matrix, Filter, and Packet Capture. They will be available on one segment chosen by the user. Use an RMON-compliant application such as ProbeView for full RMON support.

EASE

EASE (Embedded Advanced Sampling Environment) is a network monitoring and troubleshooting tool which analyzes traffic from a network-wide perspective. EASE notifies the user about trouble and identifies the end node at fault. That information can be used to set up RMON to study the problem more closely, if desired. Because it is based on statistical sampling instead of RMON's all-inclusive collection schema, EASE lessens the load on devices and network bandwidth. Thus, EASE can monitor all 4 hub backplane segments without the optional memory upgrade. See the Traffic Monitor portion of HP AdvanceStack Assistant CD-ROM for more information on using EASE.

Configuring the Switching Hubs in Software

Two Network Management Interfaces

The Management Module Pack includes two software user interfaces through which you can manage, configure, and troubleshoot your stack of hubs. The two interfaces are:

- HP AdvanceStack Assistant (formerly called HP Interconnect Manager)
- ASCII console

Depending on your hardware and management needs, choose which application best fits your needs. HP AdvanceStack Assistant runs on Windows 95 or NT 3.51 or later and does not require HP OpenView. The application works over the network. You can also manage the hubs with other network management platforms using MIB browsers.

ASCII Console Features

The text-based application is accessed through an ASCII terminal emulator program. Use either Telnet, a modem, or a direct connection by using a serial cable to the RS-232 port. Both HP AdvanceStack Assistant and the ASCII console allow you to do the following:

- display port and segment counter statistics
- view port status
- set IP/IPX configuration
- test network connectivity
- copy configuration from one hub to another
- set authorized managers and community names
- set password (ASCII console only)
- specify port switching (moving a port from one segment to the other in software instead of moving cables in the wiring closet)

(continued on next page)

- reset a specific hub to factory defaults (ASCII console only)
- enable and disable ports
- display security violations and clear them
- create backup link configuration
- select the active management module (useful when using redundant management)

HP AdvanceStack Assistant Features

HP AdvanceStack Assistant is an SNMP-compliant network management product that gives you the features above and these additional management features:

- manage multiple HP hubs and other HP network devices
- automatically generate a graphic display of the network map
- gather network traffic statistics
- display subnet topology views of SNMP-based HP devices
- launch Closeup Views for HP hub, switch, and bridge management
- set up multilevel, advanced per-port security
- save the stack configuration to your hard drive as a backup
- perform EASE traffic monitoring
- specify VLAN support
- use RMON trap configuration/graphing

To manage a Switching Hub with HP AdvanceStack Assistant over an IP network, you must first set the IP address for the hub by following the steps in appendix D, “Network Addressing”. HP AdvanceStack Assistant software and documentation are on a CD-ROM that is included with the Management Module Pack. Please refer to the CD-ROM when using that application.

The rest of this chapter describes how to connect to the ASCII console and the ASCII console features in detail.

Connecting to the ASCII Console

You can begin a console session with the hub in the following ways:

- directly, using a serial cable and a terminal (or a PC using a terminal emulator)
- remotely, using Telnet
- remotely, using a modem and a terminal/PC

The Management Module supports a single console session only. If a console session is already running, a second console session can override the first console session.

Directly, Using A Serial Cable and a Terminal

To directly connect a terminal to a hub, follow these steps:

1. Connect an ASCII terminal, or a PC emulating an ASCII terminal, to the RS-232 port using the included RS-232-C “null modem” cable. (For pin-outs and recommended cables see appendix A, “Cables and Connectors”.)
2. Switch on the terminal’s power (or switch on the PC’s power and start the terminal emulation program). Configure the terminal for 8 bits per character, 1 stop bit, no parity, Xon/Xoff handshaking, and a baud rate of 57600 to 1200.
3. Press several times for the => or Password prompt. The baud rate for communication between the hub and the terminal is sensed automatically when you press .

Remotely, Using Telnet

The Management Module support a Telnet console session. Your Telnet syntax depends on your TCP/IP software or your terminal server. By default, Telnet is enabled. You can disable Telnet by using the “Connection Configuration” screen in the ASCII console.

To establish a Telnet session, follow these steps:

1. Verify that the stack you are accessing has an HP Management Module installed, that it has been configured with an IP address, and that it is accessible from your PC or workstation.
2. In Windows NT or HP AdvanceStack Assistant, run the Telnet application and select Remote System from the Connect menu and type the IP address of the hub. For example:

```
telnet 192.1.1.1
```

or

```
telnet your_hub
```

(Your Telnet syntax depends on your TCP/IP software or your terminal server. You can use a system name if you have name resolution such as DNS.)

3. To end the Telnet session, select Logout from the main menu. Or use your Telnet application’s command to close or quit the Telnet session.

Remotely, Using a Modem and a Terminal

Use two full-duplex, asynchronous (character-mode) modems only. A list of tested modems and their initialization strings are in appendix C, “Modem Configuration”. Use the following illustration to set up a modem connection to a Switching Hub with a Management module

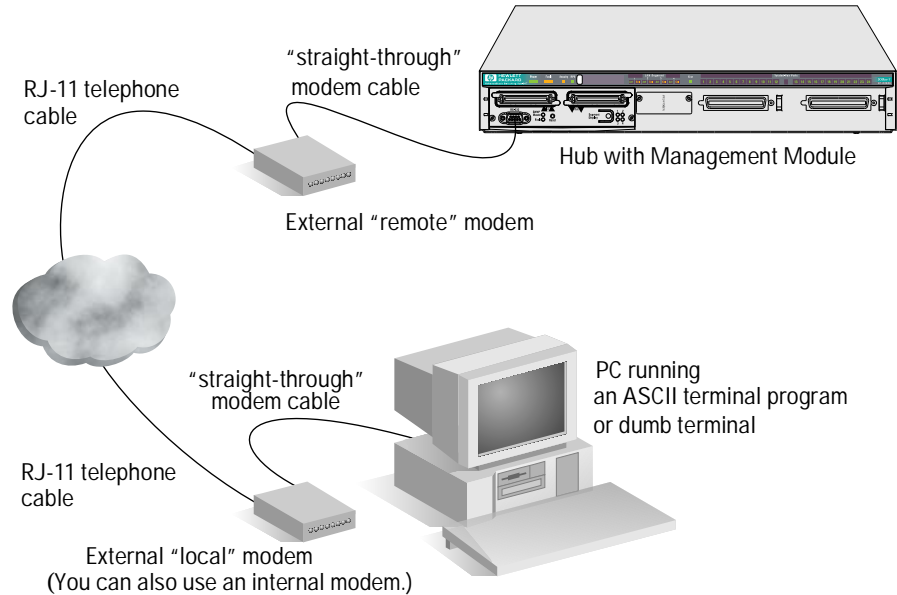

After you have set up your modems, make sure the terminal and modems are functioning properly, then establish the link between the terminal's modem and the hub's modem according to the modem instructions.

If you are using the ASCII console, press `[Return]` several times for the => or Password prompt. The baud rate for communication between the hub and the modem is set automatically when you press `[Return]`.

Using the Console

The console session starts with a display similar to the following (the actual version numbers may be different):

```
HP J3210A Switching Hub 10BT Management Module
ROM A.01.00
EEPROM A.01.00
HW A.01.00
```

Use HP AdvanceStack Assistant commands for graphical hub configuration.

Type MENU to access the ASCII menu system, or HE or? for help on console commands.

After you login, type MENU and the following menu appears:

```
HP Switching Hub Management Console
```

```
_____Main Menu _____
```

1. Hub Status and Counters...
 2. IP/IPX Configuration...
 3. Network Connectivity Tests...
 4. Port/Segment Configuration...
 5. Managers/Password Change...
 6. Security Configuration/Information...
 7. Connection Configuration...
 8. Configuration/Reset Controls...
 9. Switch Controls...
 0. Lookout
- Enter Selection =>

The menu system is easy to navigate and use. Each option is described on the next page.

Option	Description
Hub Status and Counters	Displays counters, system name, system contact, system up time, segment MAC addresses, hub port status. See the tables on the next two pages for segment and port counters.
IP/IPX Configuration	Enable/disable IP/IPX for each segment, and set addresses. For an IP address, see the instructions in appendix D, "Network Addressing".
Network Connectivity Tests	Allows you to perform IPX, link, and ping tests.
Port/Segment Configuration	<p>Disable or enable ports and set up backup links. Assign ports to a segment, isolate or connect a segment. There are 4 connected segments per stack and up to 32 isolated segments per stack.</p> <p>You can isolate up to 32 segments per stack. Note that each isolated segment can never communicate with any other hub because it is isolated from the Extender Cable.</p>
Managers/Password Change	Configure community name, set password, assign authorized managers, select the active Management Module.
Security Configuration/Information	View and clear security violations or turn off port security. (To set port the three levels of security, use HP AdvanceStack Assistant. The three levels are documented in the online help and on the CD-ROM.)
Connection Configuration	From this option, you can enable or disable Telnet connections and reset the stack. You can also connect to the Expansion Slot Module if the module has a separate ASCII console interface. (The Switch Module's interface is not separate. If a Switch Module is in the stack, new Switch commands are automatically added to the Management Module's ASCII console.)
Configuration/Reset Controls	Reset the stack, give a name to a hub, set the hub back to factory defaults, and copy configuration from one hub to another.
Switch Controls	(Only appears if an HP J3212A AdvanceStack Switch Module is installed in the stack.) Provides statistics for the switch ports and configuration options.

Port Counters

The port counters are from the IEEE 802.3 Repeater Management Specification. They are described below:

Counter Name	Definition	Valid Range	Corrective Action if over Valid Range
Good Packets	Number of error-free packets received.	Less than 4000 packets per second.*	Decrease the traffic level by using a switch to segment the network.
Collisions	Number of times the port was involved in a collision. A single collision will be counted by all ports involved, so the total collision counters may be less than the sum of the port counts.	Less than 2 times the number of good packets.	Decrease the traffic level by using a switch to segment the network Replace bad cables and/or transceivers if problems persist. Rarely, you may have a defective LAN adapter.
Late Collisions	Number of collisions which went undetected by the sending end node.	Less than .1% of good packets.	Too many repeaters between end nodes, or cables which are too long, or bad cable.
CRC/Alignment Errors	Number of packets transmitted incorrectly and number of incorrectly aligned packets.	Less than .1% of good packets.	This counter indicates faulty cabling.
Giant Packets	Number of packets larger than 1518 bytes.	Less than .1% of good packets.	Update the LAN adapter drivers on all nodes connected to the port.
Broadcast Packets	Number of packets addressed to everyone in the network. These packets consume CPU resources from each node on the network.	Less than 200 packets per second.*	Decrease the number of nodes in an IP subnet or IPX network by using more routers. Consult Novell Netware documentation on how to reduce broadcasts in an IPX network.

*The port counters in the ASCII console show totals, not number of packets per second. For the Good Packets and Broadcast packets, display counters twice over a period of one section to see if the value falls in the valid range.

Segment Counters

The Segment counters are from the RFC 1757 RMON MIB Specification. Their definition of counters is different than IEEE 802.3 Repeater Management Specification as describe din this table.

Counter Name	Definition	Valid Range	Corrective Action if over Valid Range
Good/Bad Packets	Number of error free and errored packets.	Less than 4000 packets per second.*	Decrease the traffic level by using a switch to segment the network.
Total Octets	Number of errored and error free bytes received. Shows utilization of the network. Ethernet capability is 1.25 megabytes per second.	Less than 500,000 bytes per second sustained (not just at the peak)	Decrease the traffic level by using a switch to segment the network.
Broadcast Packets	The number of packets addressed to everyone on the network. These packets consume CPU resource from each node on the network.	Less than 200 packets per second.*	Decrease the number of nodes in an IP subnet or IPX network by using more routers. Consult Novell Netware documentation on how to reduce broadcasts in an IPX network.
Multicast Packets	Number of packets sent to two or more nodes on the network, but not to broadcast.	Less than 4000 packets per second.*	Segment network and configure switches to filter unnecessary multicast packets.
Collisions	Number of times the port was involved in a collision. A single collision will be counted by all ports involved, so the total collision counters may be less than the sum of the port counts.	Less than 2 times the number of good packets.	Decrease the traffic level by using a switch to segment the network Replace bad cables and/or transceivers if problems persist. Rarely, you may have a defective LAN adapter.
CRC Alignment Errors	Number of packets transmitted incorrectly and number of incorrectly aligned packets.	Collisions + fragments should be less than 2 times the # of packets	Segment the network. Update the LAN adapter drivers.
Fragments	Number of collisions on a distant segment in the network.	Collisions + fragments should be less than 2 times the # of packets	Segment the network. Update the LAN adapter drivers.
Jabbers	Number of error packets that are longer than 20 milliseconds in duration.	Less than .1% of packets	Replace defective hardware such as the transceiver.
*The segment counters in the ASCII console show totals, not number of packets per second. For the Good/Bad Packets, Multicast, and Broadcast packets, display counters twice over a period of one section to see if the value falls in the valid range.			

Removing A Hub From a Stack

This chapter covers the following:

- number of hubs in a stack
- reinserting a hub into an existing stack

Number of Hubs Allowed In the Stack

The maximum size of a hub stack is eight hubs. If more than eight hubs are in the stack, management software (HP AdvanceStack Assistant and the ASCII console) will disable ports on that hub. Also, the Extender Cable connection on the ninth hub will be disabled, so that the ninth hub is not allowed to communicate with the stack. No configuration will be possible on extra hubs in a stack.

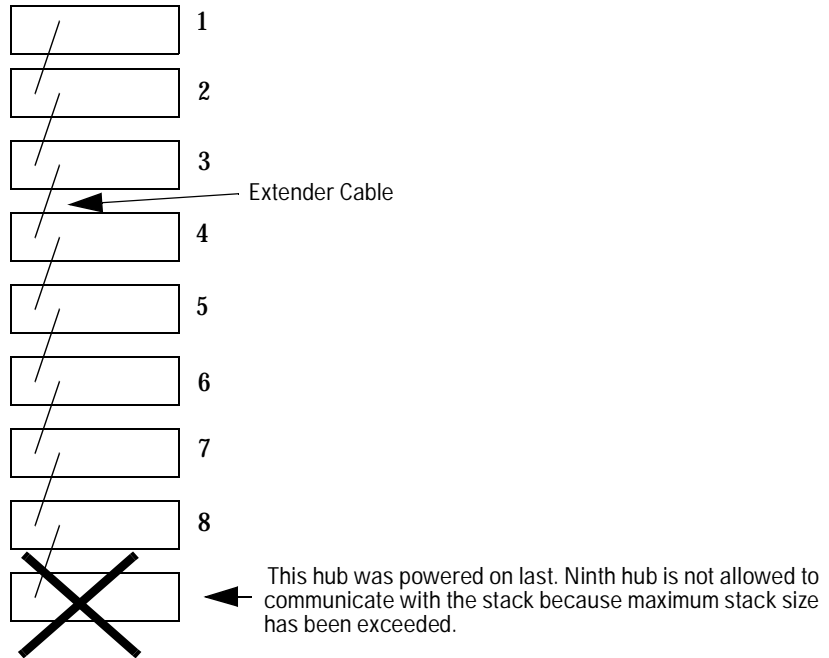

The ninth hub is the last hub powered on. Note that if all nine hubs are powered on simultaneously, then any one of the nine hubs in the stack could be ignored. Remove the ninth hub so that communication can resume between all of the hubs.

Reinserting a Hub into a Stack

If a removed hub is re-inserted back into the same stack, the Management Module remembers all of the configuration for that hub. The reinserted hub will quickly reconnect to the network and this hub will automatically be reconfigured to the same port settings it had before it was removed.

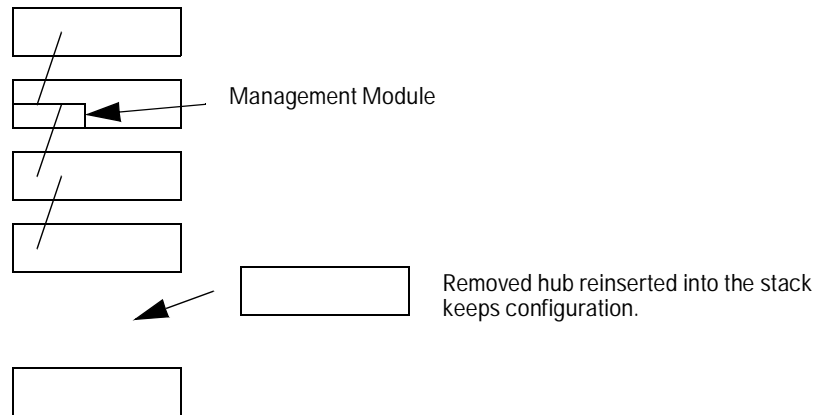

Effect on Network Connectivity When a Hub is Removed from a Stack

Network connectivity and network management flow through the Extender Cables which connect each hub together in the stack. If you need to remove a hub from a stack, the type of network connectivity lost during removal depends on which hub was removed:

Not Top or Bottom Hub: If you disconnect a hub in the middle of the stack by disconnecting the Extender Cables, network connectivity for the stack is off for the disconnected hub, and on for the connected hubs. However, the power remains on. Traffic between the two halves of the stack is resumed when the Extender Cables are reattached.

Top or Bottom Hub: If you disconnect a hub at the top or bottom of the stack, then the hubs in the middle will still communicate.

Stack Example 1

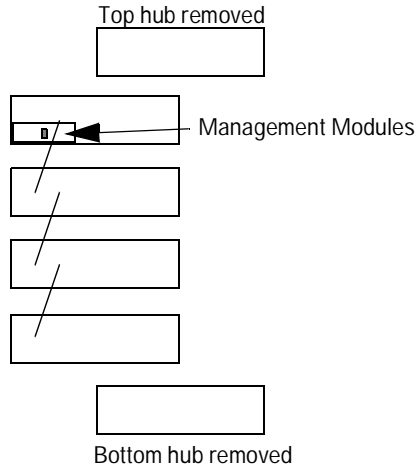

All hubs in the middle can communicate with each other.

Stack Example 2

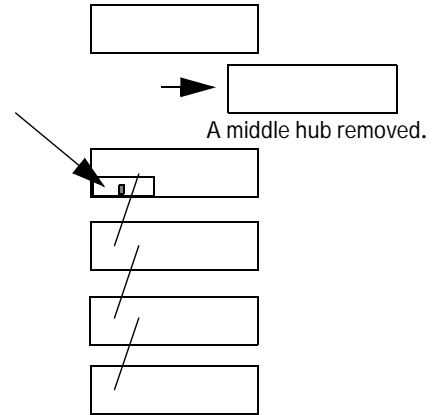

Top hub can't communicate with rest of stack. Remove an Extender Cable and connect hubs together.

If the removed hub has a Management Module, move the Management Module into another hub in the stack following the removal and installation instructions in chapter 1.

Troubleshooting

This chapter describes how to troubleshoot your Management Module and how to troubleshoot your stack of hubs for cabling problems. This chapter covers these topics:

- using the problem/solution table
- IP configuration errors
- diagnostic tests
- clearing a password for the ASCII console

Use the following table to diagnose the problem with your Management Module:

Problem	Solution
How do I reset the stack of hubs?	Either: Push the reset button on the primary Management Module. Select stack reset from the ASCII console or HP AdvanceStack Assistant.
The Segment Display button doesn't light up the 1, 2, 3 or 4 Segment LEDs.	You probably have two Management Modules installed and you are pushing buttons on the backup Management Module. Press the buttons on the module where the Active LED is on.
None of the Management Module LEDs are on.	Either: - You are looking at the backup Management Module. This is normal. - Module is loose. Make sure the Module is fully inserted and screws are tightened.
The Segment Display button lights up all of the port LEDs on Segment 1.	All of your users are on the same segment. If desired, move users to the other segments by using HP AdvanceStack Assistant or the ASCII console.
I pushed the Segment Display button. Where do I look to see which ports are on segment 1?	Instead of the port LEDs showing link status, the port LEDs for a selected segment will be lit.

Problem	Solution
<p>I am through looking at segment information. I want to see if each cable is connected correctly.</p>	<p>Either:</p> <ul style="list-style-type: none"> - After you press the Segment Display button, wait 60 seconds and then link status information will show in the port LEDs. - Press the Segment Display button until all Segment Display LEDs (1, 2, 3, and 4) are off.
<p>I can't remember the console password to configure and diagnose the hubs.</p>	<p>While the hub is on, press the Segment Display button on the Management Module for 8 seconds until the Segment Display LEDs (1, 2, 3, 4) are on solid. Then release. Then specify a new password to keep access to the hub restricted. (Steps are described at the end of this chapter.)</p>
<p>A user can't send data to another user.</p>	<p>If the users are on different segments, add a Switch Module or external switch so that the users can communicate together.</p> <p>Otherwise, use the Connectivity tests in the ASCII console or in HP AdvanceStack Assistant to test the cabling. The tests are described in this chapter.</p>
<p>I can only configure the hub in which the Management Module is installed. How do I configure the others in the stack?</p>	<p>Each hub needs to be connected to the next hub using the Extender Cable.</p>
<p>The Switch Module Fault LED is on.</p>	<p>Verify the Management Module is in the same stack. If it is, make sure the switch module is firmly seated. If problem persists, the model has an internal failure. Contact your HP authorized dealer or reseller.</p>
<p>The Security LED is flashing. How do I get it to stop?</p>	<p>Use the ASCII console or HP AdvanceStack Assistant to view the intruder log and clear the security violations.</p>

Problem	Solution
<p>I think the active Management Module isn't working anymore because the Fault LED is on. I don't have a redundant Management Module in the stack. What do I do?</p>	<p>Attempt to reset the stack by pressing the reset button on the Management Module.</p> <p>If the problem still occurs, download a current or new firmware version from the web, BBS, or CompuServe. See the perforated card at the beginning of this manual for more instructions.</p> <p>If that doesn't work, call HP for a replacement module. When the module arrives, only power down the hub with the faulty Management Module. The rest of the hubs in the stack will retain their configuration as long as they continue to receive power.</p>

If the answer to your question is not in this table, read the IP configuration and diagnostic test information on the next pages.

IP Configuration Errors

If you are using IP communications, make sure your IP configuration parameters are set properly for all segments in use. Use the ASCII console's IP Configuration function as described in chapter 3. Incorrect IP configuration on the hub will prevent it from communicating with the network management station, and may cause other network problems.

In particular, make sure you provide the hub with a unique IP address, and that you use the correct subnet mask for your network. See appendix D, "Network Addressing", for more information.

Diagnostic Tests

The HP AdvanceStack Assistant and ASCII console provide tests and indicators that can be used to monitor the hub and its network connections.

Testing the Hub Only

If you believe that the hub is not operating correctly, remove and reinsert the power cord for that hub. This procedure will cause the hub to complete its power-on self-test. If any error conditions exist in the hub, the LEDs should display the condition. See the Switching Hubs Reference manual to interpret the LED display.

Possible Failure of a Redundant Management Module

If the second Management Module takes over because the first one failed, follow these steps:

- rediscover the network if you are using HP AdvanceStack Assistant
- if you only configured bootp for other module, you'll have to configure it for the other one now.
- if you are using IP, and you do not use bootp for the IP addresses, set the IP addresses for each segment using the ASCII console. If you are using IPX, no configuration is necessary.
- if you have an RS-232 cable or modem attached to the management module, move the cable to the other module's RS-232 port

The redundant Management Module will automatically take over and configure the stack with no user intervention.

Call your HP-authorized dealer or reseller to service the Management Module.

Testing the Hub's Ports and the Links

To test the hub's ports and the attached network links, first check for link beat detection. Use these tests if you have link beat detected for a port (Port LED is on or is active in the ASCII console). Then look up the segment that the port resides on in the Port/Segment Configuration in the ASCII console. Then choose one of the following ways to run a test between the hub and an addressable device connected at the remote end of each of the cables you wish to test:

- Select **Link Test** from HP AdvanceStack Assistant's Network Test function or the ASCII console's Connectivity Tests. This causes the hub to send IEEE 802.2 Test command packets to a specified network device out a specified segment. The device must be able to send an IEEE 802.2 Test response packet upon receipt of a Test command packet. Usually this would be another network device such as a hub, switch or router. You specify the remote device by its 12-digit hexadecimal MAC address.
- Select **Ping Test**. This is a network layer test that you can run on TCP/IP networks. The hub sends ICMP Echo Request packets to a specified network device. This works with devices that have an IP address and are able to respond to an ICMP Echo Request packet. Most end nodes using IP will respond to this packet. You specify the remote device by its IP address.
- Select **IPX Test**. This is a network layer test that you can run on Novell NetWare IPX networks. The hub sends IPX test packets to a specified network device. This works with devices that have an IPX address and are able to respond to an IPX test packet. Most end nodes using IPX will respond to this packet. You specify the remote device by its IPX address.

If the test passes, the hub's port, the network link, and the remote device are all working properly. If you are testing the AUI port, this also tests the transceiver that is attached to the port.

If the test fails, you can test the hub using the "Testing the Hub Only" procedures on the previous page. You should also verify that the remote device is powered on and functioning properly, and that the cable is good, and that the device is not connected to a segment which you have isolated from the backplane.

If the hub passes its tests, but the network test (link test, Ping test, or IPX test) fails, the problem is in the cabling, the remote device, or possibly the output circuitry of the hub's port.

See the HP AdvanceStack Assistant online help for more information on how

to execute these tests.

Clearing a Password for the ASCII Console

You can use the Segment Display button to clear a forgotten console password that was previously configured on the hub. You can clear the password to access the Management Module. The password is configured from the ASCII console.

To clear the password, follow these steps:

1. Verify the hub has powered-up, passed self-test, and that the active LED is lit for the Management Module.
2. Press the Segment Display button on the Management Module for 8 seconds. (If you have installed a second Management Module in the stack, only the Segment Display button on the active Management Module can clear the password.)

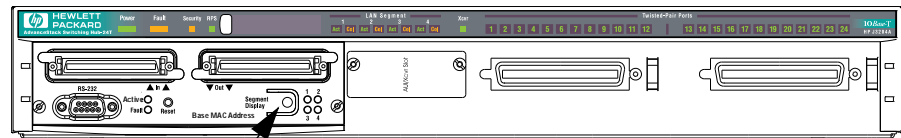

Press here for 8 seconds.

When the password is cleared, all 4 segment LEDs (1, 2, 3, and 4) will be on solid as long as the button continues to be held down.

Note

After the password has been cleared, access to the hub from the console will no longer be password protected. A new password can be assigned from the ASCII console.

HP Customer Support Services

If you are still having trouble with your stack of hubs, the following range of customer support services are helpful:

- CompuServe
- HP BBS
- HP FIRST Faxback
- World Wide Web

These services can be used to update your firmware or get information about existing or new products. See the perforated card at the beginning of this manual for more information.

Cables and Connectors

This appendix lists cables that have been tested and verified for use with the HP Management Module. It also includes minimum pin-out information so, if you wish to use an unlisted cable, you can verify that the cables used in your installation are correctly wired. Note that each pin-out does not necessarily match the pin-out for the corresponding HP cable, but cables manufactured to follow the minimum pin-out will function correctly.

Recommended Cables

Console PC connection to the module's RS-232 port:			
Purpose	Cable	Description	Part No.
Connecting the PC directly to the module's RS-232 port	9-pin male	RS-232 9-pin female to 9-pin female null modem or "cross-over" cable	F1047-80002 or F1047-60901 or 5182-4794
	25-pin male	RS-232C 9-pin female to 25-pin male null modem or "cross-over" cable	24542G (3 meters)
	25-pin female	RS-232C 9-pin female to 25-pin-female null modem or "crossover" cable	25442H (3 meter)
Connecting a modem to the hub's RS-232 port	25-pin female	RS-232C 9-pin female to 25-pin male standard modem or "straight-through" cable	HP 24542M

You can contact your HP authorized dealer or call HP at 1-800-538-8787 to order these parts.

RS-232 Connector and Cable Pin-Outs

The Management Module's RS-232 port connector is wired as depicted in the following table.

PIN	US	CCITT	DIN
1	DCD	109	M5
2	Rx	104	D2
3	Tx	103	D1
4	DTR	108	S1
5	GND	102	-
6	DSR	107	M1
7	RTS	105	S2
8	CTS	106	M2
9	RI	125	M3

Use the RS-232 port to connect a PC to be used as the console. To make this connection, you must use a null modem cable or you can use the minimum cable pin-out described below.

A Minimum Cable Pinout for ASCII Console Connection

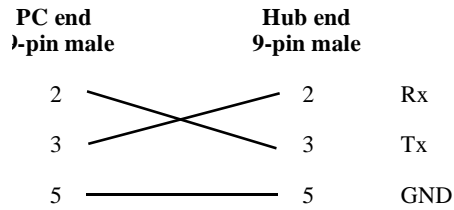

RS-232 Modem Cable

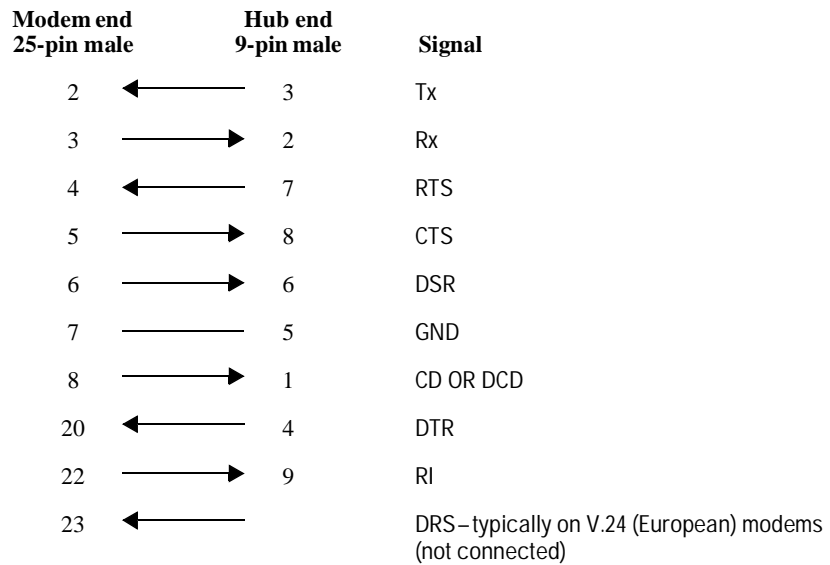

Specifications

Physical

Width	15.5 cm (6.1 in)
Depth	11.8 cm (4.6 in)
Height	4.4 cm (1.7 in)
Weight	1.3 kg (.28 lb)

Environmental

	Operating	Non-Operating
Temperature	+0°C to +55°C (32°F to 131°F)	-40°C to 70°C (-40°F to 158°F)
Relative humidity (non-condensing)	15% to 95% at 40°C (104°F)	15% to 90% at 65°C (149°F)
Maximum altitude	4.6 km (15,000 ft)	4.6 km (15,000 ft)

Connectors

The RS-232-C console port conforms to V.22 bis.

Electromagnetic

Emissions

FCC part 15 Class A
CISPR-22 Class A/EN 55022 Class A
VCCI Level 1

Immunity

(See the Declaration of Conformity at the end of the Safety and Regulatory Statements in the Switching Hubs manual)

Safety

Complies with
IEC 950: (1991)+A1,A2/.EN60950 I(1992)+A1,A2

Acoustic Noise

Not applicable

Management Protocols

RFC 1157	SNMP
RFC 1901-1908	SNMPv2C
RFC 1420	SNMP over IPX

Support MIBS

IETF 802.3	Repeater MIB
IETF	Entity MIB
RFC 1213	MIBII
RFC 1515	MAU MIB
RFC 1573	Interface Evolution MIB
RFC 1650	Ethernet MIB
RFC 1757	RMON MIB
HP MIB Extensions	Available on request. Contact your HP-authorized dealer or local HP sales office

Communication Protocols

RFC 786	UDP
RFC 791	IP
RFC 792	ICMP
RFC 793	TCP
RFC 826	ARP
RFC 854	Telnet
RFC 951	Bootp
RFC 1350	TFTP
Novell IPX	

Regulatory Statements

FCC Statement (For U.S.A. Only) Federal Communications Commission Radio Frequency Interference Statement

Note: This equipment has been tested and found to comply with the limits for a Class A digital device, pursuant to Part 15 of the FCC Rules. These limits are designed to provide reasonable protection against harmful interference when the equipment is operated in a commercial environment. This equipment generates, uses, and can radiate radio frequency energy and, if not installed and used in accordance with the instruction manual, may cause harmful interference to radio communications.

VCCI Class 1 (For Japan Only)

注意

この装置は、情報処理装置等電波障害自主規制協議会（VCCI）の基準に基づく第一種情報技術装置です。この装置を家庭環境で使用すると電波妨害を引き起こすことがあります。この場合には使用者が適切な対策を講ずるよう要求されることがあります。

European Community

This equipment complies with ISO/IEC Guide 22 and EN55022 Class A.

Note

This is a class A product. In a domestic environment, this product may cause radio interference, in which case the user may be required to take adequate measures.

Complies with Canadian EMC Class A requirements.

Modem Configuration

Before installing the modems (one attached to the hub and one attached to the terminal/PC), configure them by either issuing the appropriate AT command or by setting the modem's switches, as described in the tables in the rest of this appendix.

Hayes Smartmodem Optima 28.8 (V.34)

At the hub end:	Issue the following AT command: AT&FW2&C1&D3&K3&Q9S7=60S46=138S48=7S95=32S0=1&W
At the user end:	Issue the following AT command: AT&FW2&C1&D3&K3&Q9S7=60S46=138S48=7S95=32

Hayes ACCURA 288 V.34 + FAX

At the hub end:	Issue the following AT command: AT&FW2&C1&D3&K3&Q5S7=60S36=7S46=138S48=7S95=47S0=1&W
At the user end:	Issue the following AT command: AT&FW2&C1&D3&K3&Q5S7=60S36=7S46=138S48=7S95=47

US Robotics Courier V.FC/V.34

At the hub end:	Issue the following AT command: AT&FB0X4&A3&C1&D2&M4&H1&K1&B1S7=60S0=1&W
At the user end:	Issue the following AT command: AT&FB0X4&A3&C1&D2&M4&H1&K1&B1S7=60

Megahertz XJ2288 PCMCIA card modem

At the user end:	Issue the following AT command: AT&FW2&C1&D3&K3\J0\N3\Q3\V1% C1 "H3S7=60)
-------------------------	---

Hayes V-Series ULTRA Smartmodem 14400

At the hub end:	Issue the following AT command: AT&FS0=1&D2&S2&Y0&W0=60S0=1&W
At the user end:	Issue the following AT command: AT&F&Y0&W0=60

Practical Peripherals PM288MT II V.34

At the hub end:	Issue the following AT command: AT&F0W2&C1&D3S7=60S0=1&W0
At the user end:	Issue the following AT command: AT&F0W2&C1&D3S7=60

Intel 14.4EX

At the hub end:	Set the A/B switch to A Issue the following AT command: AT&F0&R1&W0
At the user end:	Set the A/B switch to A Issue the following AT command: AT&F0&W0

Network Addressing

Communication Between the Hub and Network Management Station

When an HP Management Module (HP J3210A) is installed in a stack of hubs, they can be managed over the network by HP network management products, for example HP AdvanceStack Assistant. These hubs can also be managed by any other network management products that comply with the Simple Network Management Protocol (SNMP) standard and have standard SNMP MIB-browser functionality.

The communication between the SNMP network management station and the hub takes place using the network layer protocols: IPX for Novell networks, or IP for TCP/IP networks.

Which protocol you use depends on the protocol being used by the network management station. Additionally, if the network management station is on the other side of a router from your hub, the protocol you run on both the hub and the network management station depends on which protocol the router can handle.

The network layer communications require that at least one of the segments of the Management Module have a network layer address. This appendix provides some background information on IPX and IP addressing.

For both IP and IPX networks, each segment receives a separate address. If you are not putting ports on segments 2-4 and you did not add the Switch Module to your stack, then you only need to assign an address to segment 1.

The Management Module is shipped with IP disabled on segments 2-4.

IPX Addressing for Novell Netware

The Novell Netware network operating system uses a protocol called Inter-network Packet Exchange (IPX). The IPX protocol firmware is always available on an HP Switching Hub stack that has a Management Module and so you do not need to do any configuration. The address is automatically assigned to the hub's segments as follows:

- The network number and encapsulation is automatically assigned by a router or file server on the network that is running the IPX protocol.
- The Management Module provides unique MAC addresses, one for each segment. This is used for the host number of the IPX address.

You may want to disable Bootp on your hub so that the hub does not poll the network every 10 minutes looking for an IP address. Disable Bootp in the ASCII console.

IPX can be configured to be enabled or disabled for each Management Module segment. The default configuration of the Management Module is for each segment to be enabled for IPX, with the network numbers and encapsulations automatically discovered. You may manually configure a router address and encapsulation if desired, although this is usually not necessary.

IPX configuration can be set through the console or through HP AdvanceStack Assistant.

IP Addresses for IP and Non-IP Networks

If you have chosen to manage your hub with an SNMP/IP network manager, your Management Module in your hub must be configured with an IP address. If your network will be connected with other networks that use IP addresses, you must use *assigned* IP addresses. Otherwise, you can build your own IP addressing scheme. The following information is described on the included CD-ROM for HP AdvanceStack Assistant:

- companies that provide IP addresses for your networks
- how to build your own IP addressing scheme
- examples of how to build class C addressing scheme

Use the IP Configuration command in HP AdvanceStack Assistant or the ASCII console to specify IP addresses.

Setting the IP Address for a Hub

Specify an IP address for the hub if you want to use HP AdvanceStack Assistant network management software. The steps to set the IP address in the ASCII console are:

1. Connect to the ASCII console as shown earlier in this chapter.
2. Type ME to enter the menu system.
3. Type 2 and press to select the IP/IPX Configuration.
4. Set the IP address for segment 1 and any other segments you plan to put users on. By default, segments 2-4 are set to "Disabled". After an IP address, subnet mask and gateway are entered, a screen like the following is displayed:

```
Current IP configuration
Time to live: 64 seconds
Interface | IP Config | IP Address | Subnet Mask | Gateway
-----|-----|-----|-----|-----
Segment 1 | Manual   | 15.29.200.16 | 255.255.248.0 | 15.29.100.1
Segment 2 | Disabled
Segment 3 | Disabled
Segment 4 | Disabled
Change IP configuration? (Y/[N]): N
```

Using Bootp

Bootp (Internet Boot Protocol) is used to download network configuration data from a server (the Bootp server) to the hub. The configuration data the hub retrieves from the Bootp server is:

- the IP address for a hub segment
- the subnet mask for the hub segment
- the default router for that hub segment

If you have configured the hub's IP parameters on a Bootp server, you do not need to use the IP Configuration command in the ASCII console or HP AdvanceStack Assistant. As shipped from the factory, the hub is configured to use Bootp to retrieve the IP configuration information. If you do not want to use Bootp because your hub is in a Novell Netware environment, Bootp can be disabled using the ASCII console. Bootp is automatically disabled if an IP address is explicitly assigned.

If you chose to manually configure a segment's IP address, it is recommended that you do not use Bootp for other segments. Instead you should either disable bootp on those segments or manually configure addresses.

The Bootp Process

When the hub is powered on, it broadcasts Bootp requests that contain the hub's MAC address. The Bootp server receives the request and searches its Bootp table file for an entry that matches the hub's MAC address. If a match is found, the configuration data in the associated file entry is returned to the hub as a Bootp reply. For most UNIX systems, the Bootp table is contained in the `/etc/bootptab` file. This example applies to the Bootp table for UNIX:

Bootp Table File Entries

An example entry in the Bootp table file `/etc/bootptab` for a Switching Hub is:

```
switchinghub:\
:ht=ether:\
:ha=080009123456:\
:ip=190.40.101.22:\
:sm=255.255.255.0:\
:gw=190.40.101.1:\
:vm=rfc1048:
```

Backup Links

Examples of Backup Links

With the Management Module in a stack of hubs, the Backup Link function allows you to specify a backup link between two devices in case the primary link fails. Three examples of backup links are shown below and on the next page

Hub to a Server

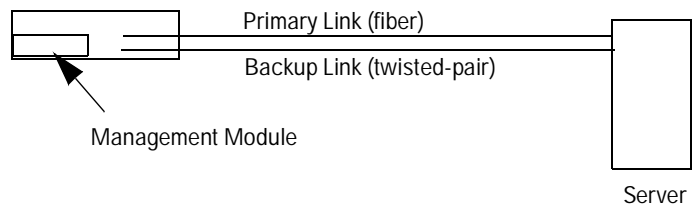

Hub to a Router

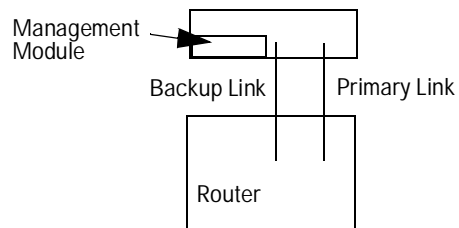

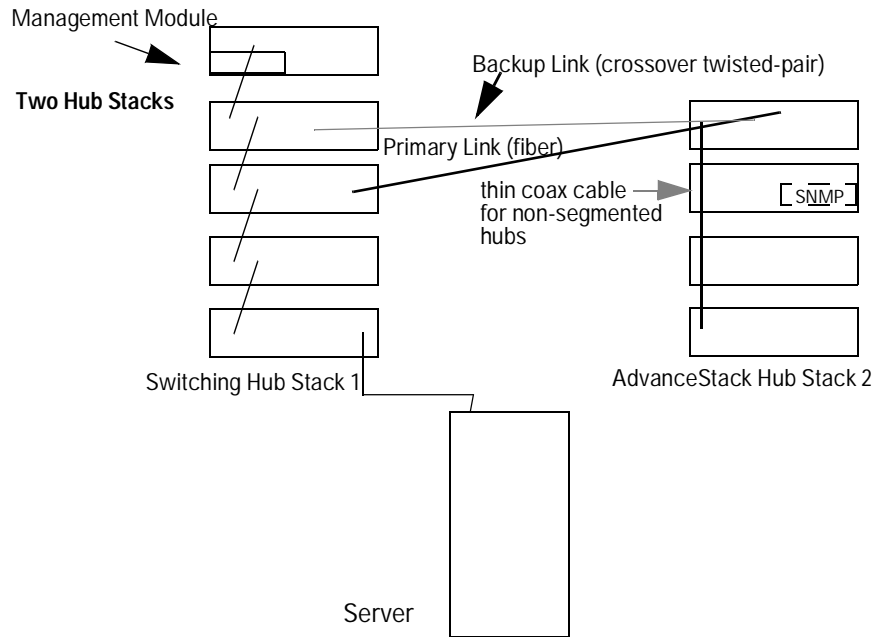

A backup link is a separate path connected between the hub and a device. The port through which the cable is connected between the two devices is automatically enabled if the connection designated as the primary link fails.

How the Backup Function Works

The hub on which the redundant link is configured is responsible for monitoring the link. It sends packets to the station at the other end of the link and looks for response packets from that station. If the response packets fail to come back, the primary link is considered as having failed and the backup link, which had not been carrying any traffic, is enabled automatically. If the primary link does fail, it is automatically disabled until it can be repaired and re-enabled.

When the primary link is repaired, you must re-enable the primary port. It is not re-enabled automatically. When the primary port is enabled, the backup port is automatically disabled and returned to backup mode. See "Reactivating the Primary Link" later in this appendix.

Note

- One hub in the stack needs an HP Management Module installed.
- The port used for the primary link must be on a segment this is connected to (not isolated from) the main four-segment backplane.
- The port used for the backup link can be on a connected or isolated segment, however it is recommended that you put the primary and backup link on the same segment.
- Any combination of media types can be used as a backup link by using the AUI/Xcvr slot. This slot accepts fiber, thin coax, twisted-pair and an AUI module for external transceivers. For example, a thin coax link from the ThinLAN port can act as a backup link to a twisted-pair link.
- A Management module can monitor up to 4 backup links in a stack. This would allow for 1 backup per segment or multiple backups on 1 segment.
- The remote device should have no more than 2 backup links connected to it from a monitoring hub. If the remote device has more than 2 backup links functioning, it may not be able to respond to the test packets fast enough when there is a high level of data traffic on the network segments.
- This ability to respond may be improved by increasing the time between test packet transmissions on the monitoring hubs. For *all* the backup links in which the remote device is involved, the time configured on the monitoring hubs for those links should be increased by one second for each additional backup link beyond two links. Add one to this count if the remote device is also functioning as a primary (monitoring) hub for a different link.

Suggestion

- - The primary link and the backup link cabling should be run over different paths (through different conduits, for example) to reduce the possibility that damage will occur to both cables simultaneously.
-

Configuring a Backup Link

Configure the Monitoring Hub Only. All configuration of the backup links feature is performed from HP AdvanceStack Assistant or the ASCII console. On the “remote” device, you only need to make sure the ports used for the primary and backup links are both enabled.

Use the Backup Function. To configure this link, you use the Backup function in HP AdvanceStack Assistant or the ASCII console. You provide the following information:

- the device and port to be used for the backup link
- the device and port to be used for the primary link
- the MAC address of the device at the remote end of the link
- how frequently (in seconds) test packets (used to check the status of the primary link) should be sent to the remote device
- how many consecutive response failures will trigger activation of the backup link

Configuration/Installation Sequence

If a hub is installed in a network that includes two connections to another hub, and the backup link has not yet been configured, a loop in the network now exists that will cause some network performance degradation. For this reason, it is better to configure the backup link on the hub before the hub is installed in the network. It is best to follow these steps:

1. Attach a PC running an ASCII terminal emulator to the hub with an active Management module, and start the ASCII terminal emulator.
2. Verify the Extender Cable is attached between all of the hubs so that you can configure a backup link on any port in the stack.
3. Use the Backup function to configure the backup link.
4. Complete the network cable connections between the monitoring hub and the remote device. For cabling instructions, see the *HP Switching Hubs Installation Guide*.
5. On the remote device, make sure that the ports connected to both the primary and backup links are enabled. On the monitoring hub, the status of the primary and backup ports is controlled by the hub's firmware; you do not need to explicitly enable the monitoring hub's ports.
6. Enable the primary port in software. This step is necessary because until you have completed step 4 (connecting the cables), the test packets cannot be successfully sent through the primary port. The primary port will therefore be disabled and the backup port will be activated. Once you enable the primary port, it assumes the active role.

Identifying the Backup Link

The ports designated as the primary and backup ports are identified in:

- the HP AdvanceStack Assistant Backup function window.
- ASCII console interface by using the Backup command

The primary port is identified by (pri), the backup port by (bkup).

Indications of Backup Link Activation

When the primary link fails (“n” consecutive test packet responses were not received on the primary port from the other device), the backup link is automatically enabled. The effect of this change is displayed on the monitoring hub's LEDs and management interface. Activation of the backup link does not change the status of any of the ports on the remote device.

On the monitoring hub's LEDs, the primary port LED goes off, and the backup port LED goes on.

In the ASCII console or HP AdvanceStack Assistant, the status of the primary port changes from “active” to “not active”, and the backup port changes from not active to active.

See the online documentation for more information.

Reactivating the Primary Link

When the primary link is repaired, you can use any of the following methods to re-enable the primary port:

- From the ASCII console, select “Port/Segment Configuration”, then “Disable and enable ports option”, then enable ports.
- From HP AdvanceStack Assistant, re-enable the primary port. See the network management product documentation for details on how to enable a port.
- Press the Reset button on the Management Module, or cycle power on the stack of hubs. These processes will reset the hub and restore the primary port's active status.

When the primary port is re-enabled, the backup port is automatically disabled and returned to backup mode.

Index

A

- ASCII console
 - features ... 3-1
- ASCII console, methods of accessing ... 3-3

B

- backup link
 - configuration process ... E-4
 - description ... E-1
 - identification ... E-5
 - indications of activation ... E-6
 - limitations ... E-3
 - operational notes ... E-3
 - reactivating the primary link ... E-6
- BOOTP ... D-4
 - example BOOTP table entry ... D-4
- broadcast packets definition ... 3-8, 3-9

C

- cables
 - RS-232 console port ... A-1
- clearing a password ... 5-6
- collisions definition ... 3-8, 3-9
- communication protocols ... B-3
- community name
 - Managers/Password menu ... 3-7
- configuring a backup link ... E-4
- Connection Configuration option
 - ASCII console ... 3-7
- console
 - cables for connecting to RS-232 port ... A-1
 - greeting screen ... 3-6
- counter definitions ... 3-8, 3-9
- CRC Errors definition ... 3-8
- customer support services ... 5-7

D

- default settings ... 2-7
- diagnostic tests ... 5-4
 - testing the hub only ... 5-4
 - testing the ports and links ... 5-5

E

- EASE description ... 2-8
- encapsulation ... D-2
- examples
 - backup links ... E-1
 - BOOTP table entry ... D-4
 - disconnecting hubs ... 4-4
 - setting an IP address ... D-3

F

- Fragments definition ... 3-9

G

- giant packets definition ... 3-8

H

- HP AdvanceStack Assistant
 - features ... 3-2
 - setting IP address ... D-3
- HP Interconnect Manager. *See* HP AdvanceStack Assistant
- HP Management Module
 - cables for ... A-1
- hub
 - default settings ... 2-7
- Hub Information option
 - ASCII console ... 3-7
- Hubs
 - number in a stack ... 4-2

I

- included parts ... 1-1
- installing
 - extra memory ... 1-2
 - module ... 1-1, 2-1
- Interconnect Manager. *See* HP AdvanceStack Assistant
- IP address ... D-3
 - setting for segments ... D-3
- IP configuration
 - errors in ... 5-3
- IP/IPX Configuration option
 - ASCII console ... 3-7
- IPX
 - encapsulation ... D-2
- IPX address ... D-2
- IPX test ... 5-5
- isolated segment ... 3-7

J

- jabbers definition ... 3-9

L

- LAN adapters
 - communication between segments ... 2-4
- link test ... 5-5

M

- MAC address
 - use in IPX address ... D-2
- Managers/Password Change option
 - ASCII console ... 3-7
- memory, adding ... 1-2
- MIBs
 - support ... B-3
- modem
 - configuration ... C-1
 - illustration of connections ... 3-5
- module
 - installing ... 1-1, 2-1
 - removing ... 1-6
- multicast packets definitions ... 3-9

N

- network addressing
 - IP address ... D-3
 - IPX address ... D-2
- Network Connectivity Test option
 - ASCII console ... 3-7
- network management
 - communication with the hub ... D-1
- Novell NetWare ... D-2

O

- on/off switch. *See* resetting the hub
- out-of-band management
 - RS-232 port pin-out ... A-2

P

- Password, clearing ... 5-6
- ping test ... 5-5
- port mobility. *See* port switching
- Port/Segment Configuration option
 - ASCII console ... 3-7
- power supply, additional. *See* HP Redundant Power Supply
- procedures
 - configuring a backup link ... E-4

R

- recommended cables
 - description ... A-1
- removing the module ... 1-6
- resetting the hub
 - troubleshooting procedure ... 5-4
- RMON
 - adding SIMM for ... 1-2
 - description ... 2-8
 - support ... 2-8
- router
 - communication between segments ... 2-4

S

Security Configuration

ASCII console ... 3-7

segment

isolating ... 3-7

Segment Display button

using ... 2-4

Segmentation

displaying in Port LEDs ... 2-4

self-test ... 1-4

serial cable connection ... 3-3

SIMM, installing ... 1-2

stack

number of hubs allowed in ... 4-2

reinserting a hub into ... 4-3

removing a hub ... 4-3

switch

communication between segments ... 2-4

T

Telnet

connection ... 3-4

disabling ... 3-4

testing

ports and links ... 5-5

troubleshooting

diagnostic tests ... 5-4

IP configuration errors ... 5-3

IPX test ... 5-5

link test ... 5-5

Ping test ... 5-5

problems and solutions ... 5-1

testing the hub ... 5-4

testing the ports and links ... 5-5

V

VLAN support ... 3-2

