



## Installation Guide

# ProCurve Switch g1/x1 Redundant Power Supply



---

ProCurve Switch gl/xl  
Redundant Power Supply

---

Installation Guide

© Copyright 2001, 2005 Hewlett-Packard Development Company, L.P. The information contained herein is subject to change without notice.

This document contains proprietary information, which is protected by copyright. No part of this document may be photocopied, reproduced, or translated into another language without the prior written consent of Hewlett-Packard.

## Publication Number

J4839-90201

May 2005

## Applicable Products

ProCurve Switch gl/xl Redundant Power Supply (J4839A)

## Disclaimer

HEWLETT-PACKARD COMPANY MAKES NO WARRANTY OF ANY KIND WITH REGARD TO THIS MATERIAL, INCLUDING, BUT NOT LIMITED TO, THE IMPLIED WARRANTIES OF MERCHANTABILITY AND FITNESS FOR A PARTICULAR PURPOSE. Hewlett-Packard shall not be liable for errors contained herein or for incidental or consequential damages in connection with the furnishing, performance, or use of this material.

The only warranties for HP products and services are set forth in the express warranty statements accompanying such products and services. Nothing herein should be construed as constituting an additional warranty. HP shall not be liable for technical or editorial errors or omissions contained herein.

Hewlett-Packard assumes no responsibility for the use or reliability of its software on equipment that is not furnished by Hewlett-Packard.

## Warranty

See the Customer Support/Warranty booklet included with the product.

A copy of the specific warranty terms applicable to your Hewlett-Packard products and replacement parts can be obtained from your HP Sales and Service Office or authorized dealer.

---

## Safety

Before installing and operating these products, please read the "Installation Cautions" on [page 3](#), and the safety information on [page 9](#).

---

---

# Contents

Description.....	1
Installing the Power Supply.....	3
Overview.....	3
Installation Cautions:.....	3
Installation Steps.....	4
Troubleshooting.....	7
Customer Support Services.....	7
Specifications.....	8
Physical.....	8
Electrical.....	8
Environmental.....	8
Safety.....	8
Safety Information.....	9
Informations concernant la sécurité.....	10
Hinweise zur Sicherheit.....	11
Considerazioni sulla sicurezza.....	12
Consideraciones sobre seguridad.....	13
Safety Information (Japan).....	14
Safety Information (China).....	15
EMC Regulatory Statements.....	16
U.S.A.....	16
Canada.....	16
Australia/New Zealand.....	16
Japan.....	16
Korea.....	17
Taiwan.....	17
European Community Declaration of Conformity.....	17

— *This page is intentionally unused.* —

---

# ProCurve Switch gl/xl Redundant Power Supply

## Description

The ProCurve Switch gl/xl Redundant Power Supply (J4839A) is a redundant power supply that you can add to any of the ProCurve Series 4100gl and Series 5300xl Switches to provide additional switch reliability.

**Features:** The ProCurve Switch gl/xl Redundant Power Supply is identical to the power unit that is preinstalled in the ProCurve Series 4100gl and Series 5300xl Switches, and has the following features:

- **power redundancy**—if either one of the power supplies should fail, the remaining supply provides the power to continue running a fully loaded Series 4100gl or Series 5300xl Switch.
- **power load sharing**—with two supplies installed, each shares the power load, which increases the life of both of the power supplies.
- **“hot swap” operation**—you can add or replace one of the Power Supplies without having to shut down or reboot the switch.
- **automatic fault detection**—if the power supply encounters a problem, the Series 4100gl and Series 5300xl Switches can immediately detect the condition and report it by way of the Power Status and Fault LEDs on the switch. Event messages will also be displayed in the switch console event log and the web browser interface Alert log.

**Included Parts.** The Switch gl/xl Redundant Power Supply has the following components shipped with it:

- *ProCurve Switch gl/xl Redundant Power Supply Installation Guide* (J4839-90201), this manual
- Customer Support/Warranty booklet

## Description

- Power cord, one of the following:

Australia/New Zealand	8120-6803	Switzerland	8120-6807
China	8120-8377	United Kingdom/ Hong Kong/Singapore	8120-8709
Continental Europe	8120-6802	United States/Canada/Mexico	8121-0605
Denmark	8120-6806		
Japan	8121-0606		

---

### Japan Power Cord Warning

製品には、同梱された電源コードをお使い下さい。  
同梱された電源コードは、他の製品では使用出来ません。

**Please use the power cord supplied with your product. This power cord is not to be used with other products.**



---

# Installing the Power Supply

## Overview

The installation steps are:

1. Install the power supply in the power supply slot in the back of the Series 4100gl or Series 5300xl Switch (see [page 4](#)).
2. Connect the power cord (see [page 5](#)).
3. Verify the power supply is installed correctly (see [page 6](#)).

### Installation Cautions:

- Make sure the power source circuits are properly grounded, then use the power cord supplied with the power supply to connect it to the power source.  
If your installation requires a different power cord than the one supplied with the power supply, be sure the cord is adequately sized for the switch's current requirements. In addition, be sure to use a power cord displaying the mark of the safety agency that defines the regulations for power cords in your country. The mark is your assurance that the power cord can be used safely with the power supply.
- When installing the switch, note that the AC outlet should be near the switch and should be easily accessible in case the switch must be powered off.
- Ensure the power supply does not overload the power circuits, wiring, and over-current protection. To determine the possibility of overloading the supply circuits, add together the ampere ratings of all devices installed on the same circuit as the switch with this power supply and compare the total with the rating limit for the circuit. The maximum ampere ratings are usually printed on the devices near their AC power connectors.
- Do not install the power supply into a switch that is in an environment where the operating ambient temperature might exceed 55°C (131°F).
- Make sure the air flow around the sides and back of the switch is not restricted.
- Make sure that for any switch power supply slot into which a power supply is not installed, the cover plate is installed to cover the slot. A cover plate is required for safe operation, and to ensure proper switch cooling.
- The switch power supplies *are* hot swappable; they can be installed or removed while the switch is receiving power from the supply in the other slot. But, as indicated by the caution statement on the power supply, the supply **must not be connected** to AC power before being installed or removed.

**Caution:**

- Refer to the installation guide for proper power cord selection.
- Disconnect AC power from this power supply BEFORE installing or removing the supply. Otherwise, damage to the equipment may result.

## Installation Steps

Follow these steps to install the power supply into the back of the switch:

1. **Remove the power supply slot cover** with either a flat-bladed or Torx T-10 screwdriver. Retain the slot cover for future use.
2. **Insert the power supply into the opening** making sure it is centered in the opening. This will assure that the guide rails on the bottom of the power supply engage the rails on the bottom of the switch. Then, slide the power supply all the way in until its bulkhead contacts the back face of the switch.

---

### Caution

---

Make sure that AC power is *not* connected to the power supply being installed before installing the power supply into the switch. The switch can be receiving power from the other power supply during the installation of the second unit.

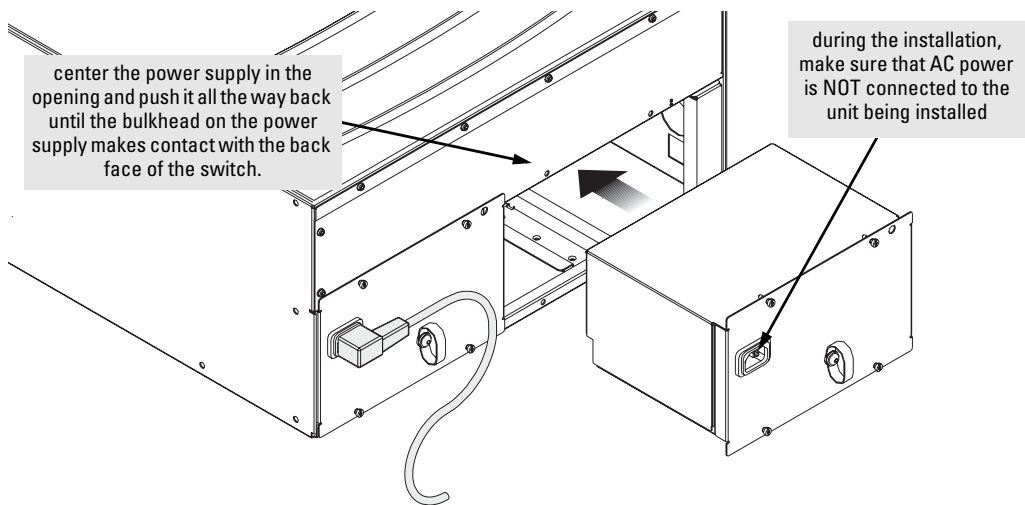

3. **Tighten the four retaining screws** that hold the power supply in place until the screws are secure, as shown in the next illustration. The screws can be tightened with either a flat-bladed or Torx T-10 screwdriver. Be careful not to overtighten the screws.

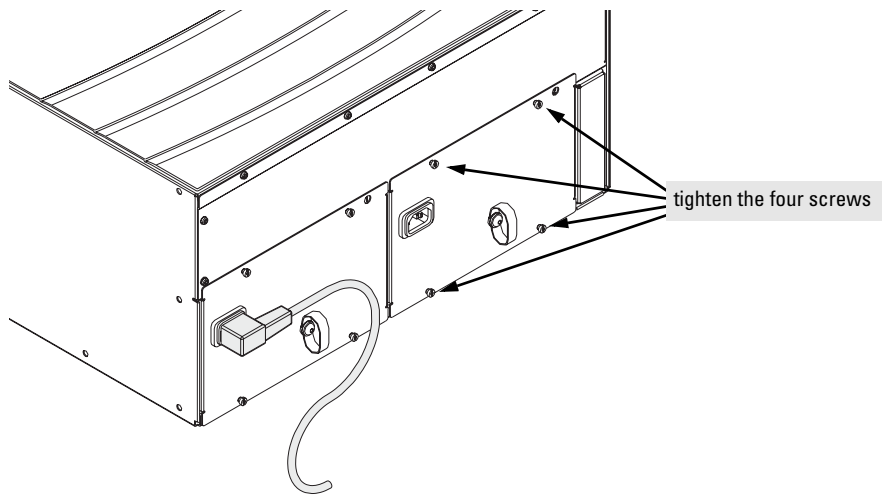

4. **Connect the power cord** supplied with the power supply to the power connector, and then into a properly grounded electrical outlet. To provide true redundancy, the second power supply should be connected to a different AC power source from the other supply. Then, if one AC power source fails, the switch will continue to run.

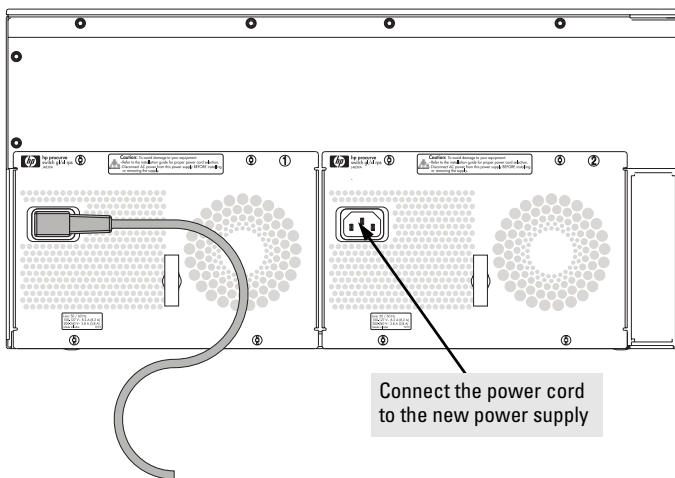

**Note**

The Switch gl/xl Redundant Power Supply does not have a power switch. It is powered on when the power cord is connected to the supply and to a power source.

Please see the “Installation Cautions” on [page 3](#).

- 5. **Verify the power supply is installed correctly** by checking the LEDs on the front of the switch. The following example shows a Series 4100gl Switch.

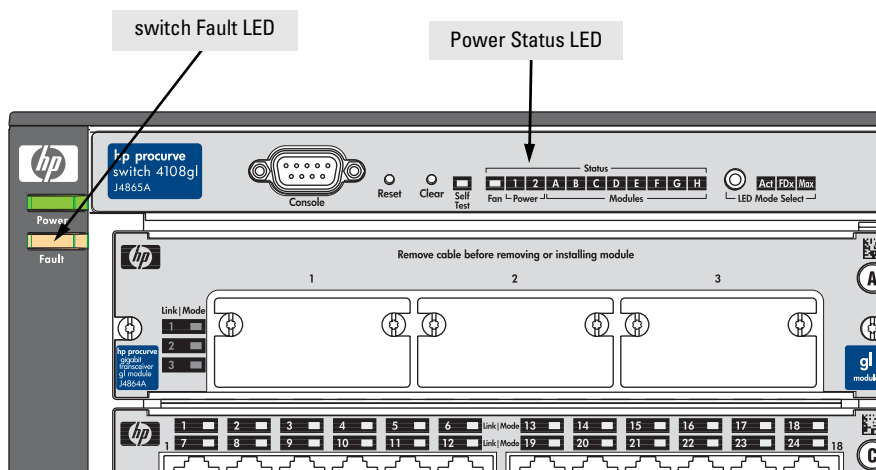

The Power Status LED for the power supply you have just installed will be blinking simultaneously with the Fault LED until that new power supply is connected to an AC power source. Once it is connected to AC power, the Power Status LED will be on continuously and not blinking, and the Fault LED will stop blinking.

If the Power Status LED and the switch Fault LED continue blinking after the power supply is connected to AC power, see “Troubleshooting” on the next page.

---

## Troubleshooting

If the Power Status LED and the switch Fault LED are blinking, either the power supply is not connected to an active AC power source, the power supply is not properly installed, or a fault condition has been detected on the power supply.

1. Verify the power cord is plugged into an active power source and to the power supply. Make sure these connections are secure. You can verify that the AC power source is active by plugging a different device into the outlet and verify that it is receiving power.
2. If the Power Status LED continues to blink, verify that the fan in the power supply is working. If it is, you can feel air being blown out of the vent holes. If it is not, try plugging the power supply into a different outlet, and/or try a different power cord.
3. If the previous steps do not resolve the problem, try removing and reinstalling the power supply.

---

### Caution

Make sure the AC power cord is disconnected from the supply before removing and reinstalling the supply.

If the power source and power cord are OK and this condition persists, the switch power supply may be faulty. Call your HP-authorized LAN dealer, or use the electronic support services from ProCurve to get assistance. See the Customer Support/Warranty booklet supplied with the power supply for more information.

---

## Customer Support Services

If you are having any trouble with your power supply or switch, Hewlett-Packard offers support 24 hours a day, seven days a week through the use of a number of automated electronic services. See the Customer Support/Warranty booklet that came with your switch or power supply for information on how to use these services to get technical support. The ProCurve networking products Web site, <http://www.procurve.com> also provides up-to-date support information.

Additionally, your HP-authorized network reseller can also provide you with assistance, both with services that they offer and with services offered by HP.

# Specifications

## Physical

<b>Width:</b>	20.1 cm (7.9 in)
<b>Depth:</b>	15.0 cm (5.9 in)
<b>Height:</b>	12.8 cm (5.1 in)
<b>Weight:</b>	1.5 kg (3.3 lbs)

## Electrical

The ProCurve Switch gl/xl Redundant Power Supply automatically adjusts to any voltage between 100-127 and 200-240 volts and either 50 or 60 Hz.

<b>AC voltage:</b>	100-127 volts	200-240 volts
<b>Maximum current:</b>	8.2 A max	3.8 A max
<b>Frequency range:</b>	50/60 Hz	50/60 Hz

## Environmental

	<b>Operating</b>	<b>Non-Operating</b>
<b>Temperature:</b>	0°C to 55°C (32°F to 131°F)	-40°C to 70°C (-40°F to 158°F)
<b>Relative humidity: (non-condensing)</b>	15% to 95% at 40°C (104°F)	15% to 90% at 65°C (149°F)
<b>Maximum altitude:</b>	4.6 Km (15,000 ft)	4.6 Km (15,000 ft)

## Safety

- EN60950 / IEC 950
- CSA 22.2 No. 950
- NOM-001-SCFI-1993
- NOM-019-SCFI-1994
- UL 1950

---

# Safety Information



Documentation reference symbol. If the product is marked with this symbol, refer to the product documentation to get more information about the product.

## **WARNING**

A **WARNING** in the manual denotes a hazard that can cause injury or death.

## Caution

A Caution in the manual denotes a hazard that can damage equipment.

Do not proceed beyond a **WARNING** or Caution notice until you have understood the hazardous conditions and have taken appropriate steps.

## **Grounding**

These are safety class I products and have protective earthing terminals. There must be an uninterruptible safety earth ground from the main power source to the product's input wiring terminals, power cord, or supplied power cord set. Whenever it is likely that the protection has been impaired, disconnect the power cord until the ground has been restored.

For LAN cable grounding:

- If your LAN covers an area served by more than one power distribution system, be sure their safety grounds are securely interconnected.
- LAN cables may occasionally be subject to hazardous transient voltages (such as lightning or disturbances in the electrical utilities power grid). Handle exposed metal components of the network with caution.

## **Servicing**

There are no user-serviceable parts inside these products. Any servicing, adjustment, maintenance, or repair must be performed only by service-trained personnel.

These products do not have a power switch; they are powered on when the power cord is plugged in.

## Informations concernant la sécurité



Symbole de référence à la documentation. Si le produit est marqué de ce symbole, reportez-vous à la documentation du produit afin d'obtenir des informations plus détaillées.

### **WARNING**

Dans la documentation, un **WARNING** indique un danger susceptible d'entraîner des dommages corporels ou la mort.

### Caution

Un texte de mise en garde intitulé Caution indique un danger susceptible de causer des dommages à l'équipement.

Ne continuez pas au-delà d'une rubrique **WARNING** ou Caution avant d'avoir bien compris les conditions présentant un danger et pris les mesures appropriées.

Cet appareil est un produit de classe I et possède une borne de mise à la terre. La source d'alimentation principale doit être munie d'une prise de terre de sécurité installée aux bornes du câblage d'entrée, sur le cordon d'alimentation ou le cordon de raccordement fourni avec le produit. Lorsque cette protection semble avoir été endommagée, débrancher le cordon d'alimentation jusqu'à ce que la mise à la terre ait été réparée.

Mise à la terre du câble de réseau local:

- si votre réseau local s'étend sur une zone desservie par plus d'un système de distribution de puissance, assurez-vous que les prises de terre de sécurité soient convenablement interconnectées.
- Les câbles de réseaux locaux peuvent occasionnellement être soumis à des surtensions transitoires dangereuses (telles que la foudre ou des perturbations dans le réseau d'alimentation public). Manipulez les composants métalliques du réseau avec précautions.

Aucune pièce contenue à l'intérieur de ce produit ne peut être réparée par l'utilisateur. Tout dépannage, réglage, entretien ou réparation devra être confié exclusivement à un personnel qualifié.

Cet appareil ne comporte pas de commutateur principal ; la mise sous tension est effectuée par branchement du cordon d'alimentation.



---

## Hinweise zur Sicherheit



Symbol für Dokumentationsverweis. Wenn das Produkt mit diesem Symbol markiert ist, schlagen Sie bitte in der Produktdokumentation nach, um mehr Informationen über das Produkt zu erhalten.

### **WARNING**

Symbol für Dokumentationsverweis. Wenn das Produkt mit diesem Symbol markiert ist, schlagen Sie bitte in der Produktdokumentation nach, um mehr Informationen über das Produkt zu erhalten.

### Caution

Symbol für Dokumentationsverweis. Wenn das Produkt mit diesem Symbol markiert ist, schlagen Sie bitte in der Produktdokumentation nach, um mehr Informationen über das Produkt zu erhalten.

Fahren Sie nach dem Hinweis **WARNING** oder Caution erst fort, nachdem Sie den Gefahrenzustand verstanden und die entsprechenden Maßnahmen ergriffen haben.

Dies ist ein Gerät der Sicherheitsklasse I und verfügt über einen schützenden Erdungsterminal. Der Betrieb des Geräts erfordert eine ununterbrochene Sicherheitserdung von der Hauptstromquelle zu den Geräteingabeterminals, den Netzkabeln oder dem mit Strom belieferten Netzkabelsatz voraus. Sobald Grund zur Annahme besteht, daß der Schutz beeinträchtigt worden ist, das Netzkabel aus der Wandsteckdose herausziehen, bis die Erdung wiederhergestellt ist.

Für LAN-Kabelerdung:

- Wenn Ihr LAN ein Gebiet umfaßt, das von mehr als einem Stromverteilungssystem beliefert wird, müssen Sie sich vergewissern, daß die Sicherheitserdungen fest untereinander verbunden sind.
- LAN-Kabel können gelegentlich gefährlichen Übergangsspannungen ausgesetzt werden (beispielsweise durch Blitz oder Störungen in dem Starkstromnetz des Elektrizitätswerks). Bei der Handhabung exponierter Metallbestandteile des Netzwerkes Vorsicht walten lassen.

Dieses Gerät enthält innen keine durch den Benutzer zu wartenden Teile. Wartungs-, Anpassungs-, Instandhaltungs- oder Reparaturarbeiten dürfen nur von geschultem Bedienungspersonal durchgeführt werden.

Dieses Gerät hat keinen Netzschalter; es wird beim Anschließen des Netzkabels eingeschaltet.

## Considerazioni sulla sicurezza



Simbolo di riferimento alla documentazione. Se il prodotto è contrassegnato da questo simbolo, fare riferimento alla documentazione sul prodotto per ulteriori informazioni su di esso.

### **WARNING**

La dicitura **WARNING** denota un pericolo che può causare lesioni o morte.

### Caution

La dicitura Caution denota un pericolo che può danneggiare le attrezzature.

Non procedere oltre un avviso di **WARNING** o di Caution prima di aver compreso le condizioni di rischio e aver provveduto alle misure del caso.

Questo prodotto è omologato nella classe di sicurezza I ed ha un terminale protettivo di collegamento a terra. Dev'essere installato un collegamento a terra di sicurezza, non interrompibile che vada dalla fonte d'alimentazione principale ai terminali d'entrata, al cavo d'alimentazione oppure al set cavo d'alimentazione fornito con il prodotto. Ogniqualvolta vi sia probabilità di danneggiamento della protezione, disinserite il cavo d'alimentazione fino a quando il collegamento a terra non sia stato ripristinato.

Per la messa a terra dei cavi LAN:

- se la vostra LAN copre un'area servita da più di un sistema di distribuzione elettrica, accertatevi che i collegamenti a terra di sicurezza siano ben collegati fra loro;
- i cavi LAN possono occasionalmente andare soggetti a pericolose tensioni transitorie (ad esempio, provocate da lampi o disturbi nella griglia d'alimentazione della società elettrica); siate cauti nel toccare parti esposte in metallo della rete.

Nessun componente di questo prodotto può essere riparato dall'utente. Qualsiasi lavoro di riparazione, messa a punto, manutenzione o assistenza va effettuato esclusivamente da personale specializzato.

Questo apparato non possiede un commutatore principale; si mette scotto tensione all'inserirsi il cavo d'alimentazione.

---

## Consideraciones sobre seguridad



Símbolo de referencia a la documentación. Si el producto va marcado con este símbolo, consultar la documentación del producto a fin de obtener mayor información sobre el producto.

### **WARNING**

Una **WARNING** en la documentación señala un riesgo que podría resultar en lesiones o la muerte.

### Caution

Una Caution en la documentación señala un riesgo que podría resultar en averías al equipo.

No proseguir después de un símbolo de **WARNING** o Caution hasta no haber entendido las condiciones peligrosas y haber tomado las medidas apropiadas.

Este aparato se enmarca dentro de la clase I de seguridad y se encuentra protegido por una borna de puesta a tierra. Es preciso que exista una puesta a tierra continua desde la toma de alimentación eléctrica hasta las bornas de los cables de entrada del aparato, el cable de alimentación o el juego de cable de alimentación suministrado. Si existe la probabilidad de que la protección a tierra haya sufrido desperfectos, desenchufar el cable de alimentación hasta haberse subsanado el problema.

Puesta a tierra del cable de la red local (LAN):

- Si la LAN abarca un área cuyo suministro eléctrico proviene de más de una red de distribución de electricidad, cerciorarse de que las puestas a tierra estén conectadas entre sí de modo seguro.
- Es posible que los cables de la LAN se vean sometidos de vez en cuando a voltajes momentáneos que entrañen peligro (rayos o alteraciones en la red de energía eléctrica). Manejar con precaución los componentes de metal de la LAN que estén al descubierto.

Este aparato no contiene pieza alguna susceptible de reparación por parte del usuario. Todas las reparaciones, ajustes o servicio de mantenimiento debe realizarlos solamente el técnico.

Este producto no tiene interruptor de potencia; se activa cuando se enchufa el cable de alimentación.

## Safety Information (Japan)

安全性の考慮

安全記号



マニュアル参照記号。製品にこの記号がついている場合はマニュアルを参照し、注意事項等をご確認ください。

**WARNING** マニュアル中の「WARNING」は人身事故の原因となる危険を示します。

**CAUTION** マニュアル中の「CAUTION」は装置破損の原因となる危険を示します。

「WARNING」や「CAUTION」の項は飛ばさないで必ずお読みください。危険性に関する記載事項をよく読み、正しい手順に従った上で次の事項に進んでください。

これは安全性クラス I の製品で保護用接地端子を備えています。主電源から製品の入力配線端子、電源コード、または添付の電源コード・セットまでの間、切れ目のない安全接地が存在することが必要です。もしこの保護回路が損なわれたことが推測されるときは、接地が修復されるまで電源コードを外しておいてください。

LAN ケーブルの接地に関して:

- もし貴社の LAN が複数の配電システムにより電力を受けている領域をカバーしている場合には、それらのシステムの安全接地が確実に相互に結合されていることを確認してください。
- LAN ケーブルは時として危険な過度電圧（例えば雷や、配電設備の電力網での障害）にさらされることがあります。露出した金属部分の取扱いには十分な注意をはらってください。

本製品の内部にはユーザーが修理できる部品はありません。サービス、調整、保守および修理はサービス訓練を受けた専門家におまかせください。

本製品には電源スイッチがありません。電源コードを接続したとき電源入となります。

---

**Japan Power  
Cord Warning**

---

**製品には、同梱された電源コードをお使い下さい。  
同梱された電源コードは、他の製品では使用出来ません。**

---

# Safety Information (China)

## HP 网络产品使用安全手册

### 使用须知

欢迎使用惠普网络产品，为了您及仪器的安全，请您务必注意如下事项：

1. 仪器要和地线相接，要使用有正确接地插头的电源线，使用中国国家规定的220V电源。
2. 避免高温和尘土多的地方，否则易引起仪器内部部件的损坏。
3. 避免接近高温，避免接近直接热源，如直射太阳光、暖气等其它发热体。
4. 不要有异物或液体落入机内，以免部件短路。
5. 不要将磁体放置于仪器附近。

### 警告

为防止火灾或触电事故，请不要将该机放置于淋雨或潮湿处。

### 安装

安装辅助管理模块，请参看安装指南。

### 保修及技术支持

如果您按照以上步骤操作时遇到了困难，或想了解其它产品性能，请按以下方式与我们联系。

如是硬件故障：

1. 与售出单位或当地维修机构联系。
2. 中国惠普有限公司维修中心地址：  
北京市海淀区知春路49号希格玛大厦  
联系电话：010-62623888 转 6101  
邮政编码：100080

如是软件问题：

1. 惠普用户响应中心热线电话：010-65645959
2. 传真自动回复系统：010-65645735

## EMC Regulatory Statements

### U.S.A.

#### FCC Class A

This equipment has been tested and found to comply with the limits for a Class A digital device, pursuant to Part 15 of the FCC Rules. These limits are designed to provide reasonable protection against interference when the equipment is operated in a commercial environment. This equipment generates, uses, and can radiate radio frequency energy and, if not installed and used in accordance with the instruction manual, may cause interference to radio communications. Operation of this equipment in a residential area may cause interference in which case the user will be required to correct the interference at his own expense.

### Canada

This product complies with Class A Canadian EMC requirements.

### Australia/New Zealand



This product complies with Australia/New Zealand EMC Class A requirements.

### Japan

#### VCCI Class A

この装置は、情報処理装置等電波障害自主規制協議会（VCCI）の基準に基づくクラスA情報技術装置です。この装置を家庭環境で使用すると電波妨害を引き起こすことがあります。この場合には使用者が適切な対策を講ずるよう要求されることがあります。

## Korea

사용자 안내문 : A 급기기

이기는 업무용으로 전자파 적합등록을 받은 기기 이오니, 판매자 또는 사용자는 이점을 주의하시기 바라며, 만약 잘못 구입하셨을 때에는 구입한 곳에서 비업무용으로 교환하시기 바랍니다.

## Taiwan

警告使用者：這是甲類的資訊產品，在居住的環境中使用時，可能會造成射頻干擾，在這種情況下，使用者會被要求採取某些適當的對策。

## European Community Declaration of Conformity

This product is designed for operation with the ProCurve Series 4100gl and Series 5300xl Switches. Please see the Declaration of Conformity included in the *Installation and Getting Started Guide* included with the switch.

— *This page is intentionally unused.* —



— *This page is intentionally unused.* —

— *This page is intentionally unused.* —



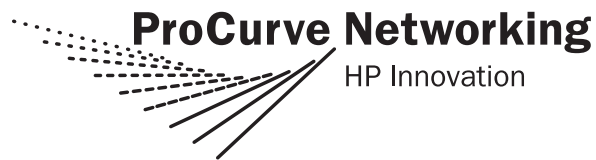

Technical information in this document is subject to change without notice.

© Copyright Hewlett-Packard Company, 2001, 2005. All rights reserved. Reproduction, adaptation, or translation without prior written permission is prohibited except as allowed under the copyright laws.

Printed in Singapore  
May 2005

Manual Part Number  
J4839-90201

