

Port Trunking

Contents

Overview	12-2
Port Status and Configuration	12-2
Port Connections and Configuration	12-3
Link Connections	12-3
Trunk Group Boundary Requirement with IP Routing Enabled on the Series 2800 Switch	12-3
Trunk Group Boundary Requirement for the Series 4100gl Switch 10/100/1000 Module (J4908A)	12-4
Port Trunk Options and Operation	12-5
Trunk Configuration Methods	12-5
Menu: Viewing and Configuring a Static Trunk Group	12-10
CLI: Viewing and Configuring a Static or Dynamic Port Trunk Group	12-12
Using the CLI To View Port Trunks	12-12
Using the CLI To Configure a Static or Dynamic Trunk Group	12-15
Web: Viewing Existing Port Trunk Groups	12-18
Trunk Group Operation Using LACP	12-18
Default Port Operation	12-21
LACP Notes and Restrictions	12-23
Trunk Group Operation Using the “Trunk” Option	12-25
How the Switch Lists Trunk Data	12-25
Outbound Traffic Distribution Across Trunked Links	12-26

Overview

This chapter describes creating and modifying port trunk groups. This includes non-protocol trunks and LACP (802.3ad) trunks.

Port Status and Configuration

Feature	Default	Menu	CLI	Web
viewing port trunks	n/a	page 12-10	page 12-12	page 12-18
configuring a static trunk group	none	page 12-10	page 12-16	—
configuring a dynamic LACP trunk group	LACP passive	—	page 12-16	—

Port trunking allows you to assign physical links to one logical link (trunk) that functions as a single, higher-speed link providing dramatically increased bandwidth. This capability applies to connections between backbone devices as well as to connections in other network areas where traffic bottlenecks exist.

Port Trunking Support	ProCurve Series 2600, 2600-PWR Switch	ProCurve Series 2800 Switch	ProCurve Series 4100gl Switch	ProCurve 6108 Switch
Ports per trunk (maximum)	4	8	4	4
Trunks per switch (maximum)	6	24	6	6

A *trunk group* is a set of ports configured as members of the same port trunk. Note that the ports in a trunk group do not have to be consecutive. For example:

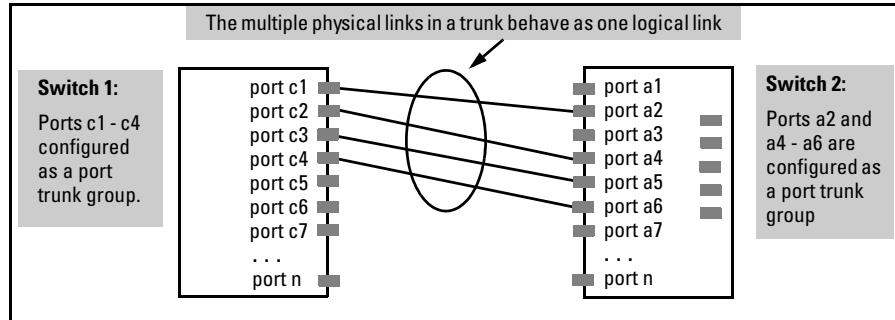

Figure 12-1. Conceptual Example of Port Trunking

Port Connections and Configuration

All port trunk links must be point-to-point connections between the switch and a router, server, workstation, or another switch configured for port trunking. No intervening, non-trunking devices are allowed. It is important to note that ports on both ends of a port trunk group must have the same mode (speed and duplex) and flow control settings.

Note

Link Connections

The switch does not support trunking through an intermediate, non-trunking device such as a hub, or using more than one media type in a port trunk group. Similarly, all links in the same trunk group must have the same speed, duplex, and flow control.

Trunk Group Boundary Requirement with IP Routing Enabled on the Series 2800 Switch

On the Switch 2824 and Switch 2848, trunk groups can generally be specified as any grouping of ports on the switch. However, if IP routing is enabled on the switch, all of the ports in a given trunk group must be in the same group of ports, as shown in table 2.

Table 10-2. Port Group Boundaries when IP Routing Enabled - 2800 Switches

Port Groups				
Switch 2824	1 - 12	13 - 24	<i>n/a</i>	<i>n/a</i>
Switch 2848	1 - 12	13 - 24	25-36	37 - 48

For example:

```
ProCurve (config)# trunk 1-8 trk1
```

This command is valid in all cases (switching or routing) because all of the ports are in the same port group.

```
ProCurve (config)# trunk 9-14 trk2
```

This command is NOT valid if IP routing is enabled on the switch (because the selected ports are in different port groups and IP routing is enabled). If IP routing is enabled, this command generates an error message and will not be executed.

If a trunk group with ports in different port groups is created before IP routing is enabled, then using the **ip routing** command to enable IP routing generates an error message indicating the trunk group that violates the above rule. You can remedy this problem by reducing the trunk to only the ports that are in the same port group. To remove ports from an existing trunk, use the following command:

```
ProCurve (config)# no trunk <ports-to-remove >
```

Trunk Group Boundary Requirement for the Series 4100gl Switch 10/100/1000 Module (J4908A)

On the J4908A, a trunk group (manual or dynamic LACP) must be comprised of ports from the same port group, as shown in table 3.

Table 10-3. Port Group Boundaries for Trunks on a Series 4100gl Switch 10/100/1000 Module (J4908A):

	Ports
Group 1	1 - 5, 7 - 11, 16
Group 2	6, 12 - 15, 17 - 22

Manually or dynamically configuring a trunk with ports in different groups is not supported. For example, configuring a port trunk with ports 10-14 is not supported because the ports used are from two separate groups. (Refer to “Trunk Group Boundary Requirement for the Series 4100gl Switch 10/100/1000 Module (J4908A)” in table 12-3 on page 12-8.)

Port Security Restriction. Port security does not operate on a trunk group. If you configure port security on one or more ports that are later added to a trunk group, the switch resets the port security parameters for those ports to the factory-default configuration.

Caution

To avoid broadcast storms or loops in your network while configuring a trunk, first disable or disconnect all ports you want to add to or remove from the trunk. After you configure the trunk, enable or re-connect the ports.

Port Trunk Options and Operation

The switch offers these options for port trunking:

- LACP (IEEE 802.3ad—page 12-18)
- Trunk (non-protocol—page 12-25)

The switch supports six trunk groups of up to four ports each. (Using the Link Aggregation Control Protocol—LACP—option, you can include standby trunked ports in addition to the maximum of four actively trunking ports.)

LACP Note

LACP operation requires full-duplex (FDx) links. For most installations, HP recommends that you leave the port Mode settings at **Auto** (the default). LACP also operates with **Auto-10**, **Auto-100**, and **Auto-1000** (if negotiation selects FDx); **10FDx**, **100FDx**, and **1000FDx** settings.

Fault Tolerance: If a link in a port trunk fails, the switch redistributes traffic originally destined for that link to the remaining links in the trunk. The trunk remains operable as long as there is at least one link in operation. If a link is restored, that link is automatically included in the traffic distribution again. The LACP option also offers a standby link capability, which enables you to keep links in reserve for service if one or more of the original active links fails. See “Trunk Group Operation Using LACP” on page 12-18.)

Trunk Configuration Methods

Dynamic LACP Trunk: The switch automatically negotiates trunked links between LACP-configured ports on separate devices, and offers one dynamic trunk option: LACP. To configure the switch to initiate a dynamic LACP trunk with another device, use the **interface ethernet** command in the CLI to set the default LACP option to **Active** on the ports you want to use for the trunk. For example, the following command configures ports C1-C4 to LACP active:

```
ProCurve(config) int c1-c4 lacp active
```

Note that the above example works if the ports are not already operating in a trunk. To change the LACP option on ports already operating as a trunk, you must first disable the trunked ports that you want to reconfigure. For example, if ports C1 - C4 were LACP-active and operating in a trunk with another device, you would do the following to change them to LACP-passive:

1. Go to the port context for ports c1 - c4 and disable these ports.

```
ProCurve(config)# interface c1-c4  
ProCurve(eth-c1-c4)#_  
ProCurve(eth-c1-c4)# disable
```

2. Change all four ports to LACP-passive and re-enable the ports.

```
ProCurve(eth-c1-c4)# lacp passive  
ProCurve(eth-c1-c4)# enable
```

Note

If you change the port trunk configuration on a link, ensure that the port trunk configuration on the other end of the link matches the new configuration.

On Switch 2800 Series devices, ensure that all ports in a dynamic trunk belong to the same port group. The Switch 2800 Series devices do not support trunks comprised of ports from different port groups. (Refer to "Trunk Group Boundary Requirement for Switch 2800 Series Devices" in table 12-3 on page 12-8.)

Static Trunk: The switch uses the links you configure with the Port/Trunk Settings screen in the menu interface or the **trunk** command in the CLI to create a static port trunk. The switch offers LACP and Trunk static trunks.

Table 12-1. Trunk Types Used in Static and Dynamic Trunk Groups

Trunking Method	LACP	Trunk
Dynamic	Yes	No
Static	Yes	Yes

Table 12-2. Trunk Configuration Protocols

Protocol	Trunking Options
LACP (802.3ad)	<p>Provides dynamic and static LACP trunking options.</p> <ul style="list-style-type: none"> • Dynamic LACP — Use the switch-negotiated dynamic LACP trunk when: <ul style="list-style-type: none"> – The port on the other end of the trunk link is configured for Active or Passive LACP. – You want to achieve fault-tolerance for high-availability applications where you want a four-link trunk (2600, 2600-PWR, 4100gl, and 6108) or an eight-link trunk (2800) with one or more standby links available in case an active link goes down. (Both ends of the link must be dynamic LACP.) • Static LACP — Use the manually configured static LACP trunk when: <ul style="list-style-type: none"> – The port on the other end of the trunk link is configured for a static LACP trunk – You want to configure non-default spanning tree (STP) or IGMP parameters on an LACP trunk group. – You want an LACP trunk group to operate in a VLAN other than the default VLAN and GVRP is disabled. (Refer to “VLANs and Dynamic LACP” on page 12-24.) – You want to use a monitor port on the switch to monitor an LACP trunk. <p>See “Trunk Group Operation Using LACP” on page 12-18.</p>
Trunk (non-protocol)	<p>Provides manually configured, static-only trunking to:</p> <ul style="list-style-type: none"> • Most HP switches and routing switches not running the 802.3ad LACP protocol. • Windows NT and HP-UX workstations and servers <p>Use the Trunk option when:</p> <ul style="list-style-type: none"> – The device to which you want to create a trunk link is using a non-802.3ad trunking protocol – You are unsure which type of trunk to use, or the device to which you want to create a trunk link is using an unknown trunking protocol. – You want to use a monitor port on the switch to monitor traffic on a trunk. <p>Refer to “Trunk Group Operation Using the “Trunk” Option” on page 12-25.</p>

Table 12-3. General Operating Rules for Port Trunks

Media: All ports on both ends of a trunk group must have the same media type and mode (speed and duplex). The switch blocks any trunked links that do not conform to this rule. (For the switches covered in this guide, HP recommends leaving the port Mode setting at **Auto** or, in networks using Cat 3 cabling, **Auto-10**.)

Port Configuration: The default port configuration is Auto, which enables a port to sense speed and negotiate duplex with an Auto-enabled port on another device. HP recommends that you use the **Auto** setting for all ports you plan to use for trunking. Otherwise, you must manually ensure that the mode setting for each port in a trunk is compatible with the other ports in the trunk.

```
HPswitch(config)# show interface config
Port Settings
-----+-----
C1  10/100TX | Yes   Auto  Disable
C2  10/100TX | Yes   Auto  Disable
```

Recommended Port Mode Setting for LACP

All of the following operate on a per-port basis, regardless of trunk membership:

- Enable/Disable
- Flow control (Flow Ctrl)

LACP is a full-duplex protocol. See “Trunk Group Operation Using LACP” on page 12-18.

Trunk Configuration: All ports in the same trunk group must be the same trunk type (LACP or Trunk). All LACP ports in the same trunk group must be either all static LACP or all dynamic LACP.

A trunk appears as a single port labeled **Dyn1** (for an LACP dynamic trunk) or **Trk1** (for a static trunk of any type: LACP or Trunk) on various menu and CLI screens. For a listing of which screens show which trunk types, see “How the Switch Lists Trunk Data” on page 12-25.

For STP or VLAN operation, configuration for all ports in a trunk is done at the trunk level. (You cannot separately configure individual ports within a trunk for STP or VLAN operation.)

Traffic Distribution: All of the switch trunk protocols use the SA/DA (Source Address/Destination Address) method of distributing traffic across the trunked links. See “Outbound Traffic Distribution Across Trunked Links” on page 12-26.

Trunk Group Boundary Requirement for the Series 2800 Switches When IP Routing is Enabled: On the Switch 2824 and Switch 2848, manually or dynamically configuring a trunk with ports belonging to different port groups is not supported if IP routing is enabled. Each trunk group must be comprised only of ports from the same port group, as shown below:

- Ports 1- 12 (Switch 2824 and 2848.)
- Ports 13 - 24 (Switch 2824 and 2848.)
- Ports 25 - 36 (Switch 2848 only.)
- Ports 37 - 48 (Switch 2848 only.)

For example, you can configure a new trunk (or the switch can dynamically configure an LACP trunk) comprised of ports 1, 3, 4, 7, 8, 10, 11, and 12, and another trunk comprised of ports 13, 14, 17, 18, 20, 21, 22, and 24. However, for example, configuring a trunk, or allowing a dynamic LACP trunk to occur with some ports in the range of 1 - 12 and other ports in the range of 13 - 24 is not supported if IP routing is enabled. When IP routing is disabled, any eligible switch ports (having the same media type and mode (speed and duplex)) can be used in a trunk group,

Trunk Group Boundary Requirement for the Series 4100gl Switch 10/100/1000 Module (J4908A): Trunks must be created, manually or dynamically, with ports from the same group, Group1 or Group2.

Group1: Ports 1-5, 7-11, 16

Group2: Ports 6, 12-15, 17-22

For example, a trunk made up of ports 3 - 5 is valid; a trunk made up of ports 4 - 6 is not (port 6 is a member of Group2, not Group 1. Ports 21 and 22, for use with mini-GBICs, may be used to form a trunk.

Spanning Tree: Spanning Tree operates as a global setting on the switch (one instance of Spanning Tree per switch). However, you can adjust Spanning Tree parameters on a per-port basis. A static trunk of any type appears in the Spanning Tree configuration display, and you can configure Spanning Tree parameters for a static trunk in the same way that you would configure Spanning Tree parameters on a non-trunked port. (Note that the switch lists the trunk by name—such as **Trk1**—and does not list the individual ports in the trunk.) For example, if ports C1 and C2 are configured as a static trunk named **Trk1**, they are listed in the Spanning Tree display as **Trk1** and do not appear as individual ports in the Spanning Tree displays.

In this example showing part of the **show spanning-tree** listing, ports C1 and C2 are members of TRK1 and do not appear as individual ports in the port configuration part of the listing.

Port	Type	Cost	Priority	State	Designated Bridge
C3	100/1000T	5	128	Forwarding	0020c1-b27ac0
C4	100/1000T	5	128	Forwarding	0060b0-889e00
C5	100/1000T	5	128	Disabled	
C6	100/1000T	5	128	Disabled	
Trk1		1	64	Forwarding	0001e7-a0ec00

When Spanning Tree forwards on a trunk, all ports in the trunk will be forwarding. Conversely, when Spanning Tree blocks a trunk, all ports in the trunk are blocked.

Note: A dynamic LACP trunk operates only with the default Spanning Tree settings and does not appear in the Spanning Tree configuration display or **show ip igmp** listing.

If you remove a port from a static trunk, the port retains the same Spanning Tree settings that were configured for the trunk.

IP Multicast Protocol (IGMP): A static trunk of any type appears in the IGMP configuration display, and you can configure IGMP for a static trunk in the same way that you would configure IGMP on a non-trunked port. (Note that the switch lists the trunk by name—such as **Trk1**—and does not list the individual ports in the trunk.) Also, creating a new trunk automatically places the trunk in IGMP Auto status if IGMP is enabled for the default VLAN. A dynamic LACP trunk operates only with the default IGMP settings and does not appear in the IGMP configuration display or **show ip igmp** listing.

VLANs: Creating a new trunk automatically places the trunk in the DEFAULT_VLAN, regardless of whether the ports in the trunk were in another VLAN. Similarly, removing a port from a trunk group automatically places the port in the default VLAN. You can configure a static trunk in the same way that you configure a port for membership in any VLAN.

Note: For a dynamic trunk to operate in a VLAN other than the default VLAN (DEFAULT_VLAN), GVRP must be enabled. See “Trunk Group Operation Using LACP” on page 12-18.

Port Security: Trunk groups (and their individual ports) cannot be configured for port security, and the switch excludes trunked ports from the **show port-security** listing. If you configure non-default port security settings for a port, then subsequently try to place the port in a trunk, you will see the following message and the command will not be executed:

```
< port-list > Command cannot operate over a logical port.
```

Monitor Port:

Note: A trunk cannot be a monitor port. A monitor port can monitor a static trunk but cannot monitor a dynamic LACP trunk.

Menu: Viewing and Configuring a Static Trunk Group

Important

Configure port trunking *before* you connect the trunked links to another switch, routing switch, or server. Otherwise, a broadcast storm could occur. (If you need to connect the ports before configuring them for trunking, you can temporarily disable the ports until the trunk is configured. See “Using the CLI To Configure Ports” on page 10-10.)

To View and/or Configure Static Port Trunking: This procedure uses the Port/Trunk Settings screen to configure a static port trunk group on the switch.

1. Follow the procedures in the Important note above.
2. From the Main Menu, Select:
2. Switch Configuration . . .
2. Port/Trunk Settings
3. Press [E] (for **E**dit) and then use the arrow keys to access the port trunk parameters.

```
----- CONSOLE - MANAGER MODE -----
                          Switch Configuration - Port/Trunk Settings
-----+-----
Port      Type      Enabled  Mode      Flow Ctrl  Group      Type
-----+-----
C1       10/100TX | Yes      Auto      Disable    -----
C2       10/100TX | Yes      Auto      Disable    -----
C3       10/100TX | Yes      Auto      Disable    -----
C4       10/100TX | Yes      Auto      Disable    -----
C5       10/100TX | Yes      Auto      Disable    -----
C6       10/100TX | Yes      Auto      Disable    -----

Actions->  Cancel      Edit      Save      Help

Select Yes to enable the port, No to disable.
Use arrow keys to change field selection, <Space> to toggle field choices,
and <Enter> to go to Actions.
```

Figure 12-4. Example of the Menu Screen for Configuring a Port Trunk Group

4. In the Group column, move the cursor to the port you want to configure.
5. Use the Space bar to choose a trunk group (**Trk1**, **Trk2** . . .) trunk group assignment for the selected port.

- All ports in a trunk must have the same media type and mode (such as 10/100TX set to 100FDx, or 100FX set to 100FDx). The flow control settings must also be the same for all ports in a given trunk. To verify these settings, see “Viewing Port Status and Configuring Port Parameters” on page 10-3.
- You can configure the trunk group with one, two, three, or four ports per trunk (2600, 2600-PWR, 4100gl, and 6108 switches) or with one to eight ports (2800 switches). If multiple VLANs are configured, all ports within a trunk will be assigned to the same VLAN or set of VLANs. (With the 802.1Q VLAN capability built into the switch, more than one VLAN can be assigned to a trunk. See the chapter “Port-Based Virtual LANs (VLANs) and GVRP” in the *Advanced Traffic Management Guide*.)

(To return a port to a non-trunk status, keep pressing the Space bar until a blank appears in the highlighted Group value for that port.)

```

===== CONSOLE - MANAGER MODE =====
Switch Configuration - Port/Trunk Settings

Port   Type      Enabled  Mode      Flow Ctrl  Group  Type
-----+-----+-----+-----+-----+-----+-----
C1     10/100TX | Yes     Auto      Disable    -----
C2     10/100TX | Yes     Auto      Disable    -----
C3     10/100TX | Yes     Auto      Disable    -----
C4     10/100TX | Yes     Auto      Disable    -----
C5     10/100TX | Yes     Auto      Disable    Trk1  Trunk
C6     10/100TX | Yes     Auto      Disable    Trk1  Trunk

Actions->  Cancell  Edit     Save     Help

Select whether the port is part of a trunk or Mesh.
Use arrow keys to change field selection, <Space> to toggle field choices,
and <Enter> to go to Actions.

```

Figure 12-5. Example of the Configuration for a Two-Port Trunk Group

6. Move the cursor to the Type column for the selected port and use the Space bar to select the trunk type:
 - LACP
 - Trunk (the default type if you do not specify a type)

All ports in the same trunk group on the same switch must have the same Type (**LACP** or **Trunk**).

7. When you are finished assigning ports to the trunk group, press **[Enter]**, then **[S]** (for **Save**) and return to the Main Menu. (It is not necessary to reboot the switch.)

During the Save process, traffic on the ports configured for trunking will be delayed for several seconds. If the Spanning Tree Protocol is enabled, the delay may be up to 30 seconds.

8. Connect the trunked ports on the switch to the corresponding ports on the opposite device. If you previously disabled any of the trunked ports on the switch, enable them now. (See “Viewing Port Status and Configuring Port Parameters” on page 10-3.)

Check the Event Log (“Using Logging To Identify Problem Sources” on page C-23) to verify that the trunked ports are operating properly.

CLI: Viewing and Configuring a Static or Dynamic Port Trunk Group

Trunk Status and Configuration Commands

show trunks	below
show lacp	page 12-14
trunk	page 12-16
interface lacp	page 12-16

Using the CLI To View Port Trunks

You can list the trunk type and group for all ports on the switch or for selected ports. You can also list LACP-only status information for LACP-configured ports.

Listing Static Trunk Type and Group for All Ports or Selected Ports.

Syntax: show trunks [<port-list>]

Omitting the < **port-list** > parameter results in a static trunk data listing for all LAN ports in the switch. For example, in a switch where ports A4 and A5 belong to Trunk 1 and ports A7 and A8 belong to Trunk 2, you have the options shown in figures 12-6 and 12-7 for displaying port data for ports belonging to static trunks.

Using a port list specifies, for switch ports in a static trunk group, only the ports you want to view. In this case, the command specifies ports A5 through A7. However, because port A6 is not in a static trunk group, it does not appear in the resulting listing:

Port A5 appears with an example of a name that you can optionally assign using the Friendly PortNames feature. (See "Using Friendly (Optional) PortNames" on page 10-33.)

```

ProCurve> show trunks a5-a7

Load Balancing

  Port | Name | Type | Group | Type
-----+-----+-----+-----+-----
  A5   | Print-Server-Trunk | 10/100TX | Trk1 | Trunk
  A7   | not assigned | 10/100TX | Trk2 | Trunk
    
```

Port A6 does not appear in this listing because it is not assigned to a static trunk.

Figure 12-6. Example Listing Specific Ports Belonging to Static Trunks

The **show trunks <port-list>** command in the above example includes a port list, and thus shows trunk group information only for specific ports that have membership in a static trunk. In figure 12-7, the command does not include a port list, so the switch lists all ports having static trunk membership.

```

ProCurve> show trunks

Load Balancing

  Port | Name | Type | Group | Type
-----+-----+-----+-----+-----
  A4   | Print-Server-Trunk | 10/100TX | Trk1 | Trunk
  A5   | Print-Server-Trunk | 10/100TX | Trk1 | Trunk
  A7   | not assigned | 10/100TX | Trk2 | Trunk
  A8   | not assigned | 10/100TX | Trk2 | Trunk
    
```

Figure 12-7. Example of a Show Trunk Listing Without Specifying Ports

Listing Static LACP and Dynamic LACP Trunk Data. This command lists data for only the LACP-configured ports.

Syntax: show lacp

In the following example, ports A1 and A2 have been previously configured for a static LACP trunk. (For more on “Active”, see table 12-5 on page 12-22.)

```
ProCurve> show lacp
```

LACP					
PORT NUMB	LACP ENABLED	TRUNK GROUP	PORT STATUS	LACP PARTNER	LACP STATUS
A1	Active	Trk1	Up	Yes	Success
A2	Active	Trk1	Up	Yes	Success
A3	Active	A3	Down	No	Success
A4	Passive	A4	Down	No	Success
A5	Passive	A5	Down	No	Success
A6	Passive	A6	Down	No	Success

Figure 12-8. Example of a Show LACP Listing

Dynamic LACP Standby Links. Dynamic LACP trunking enables you to configure standby links for a trunk by including more than the maximum number of allowed ports in a dynamic LACP trunk configuration. When the maximum number of allowed ports (trunk links) are up, the remaining link(s) will be held in standby status. If a trunked link that is “Up” fails, it will be replaced by a standby link, which maintains your intended bandwidth for the trunk. (See also the “Standby” entry under “Port Status” in table 12-5, “LACP Port Status Data”, on page 12-22.) In the next example, ports A1 through A5 have been configured for the same dynamic LACP trunk, even though a maximum of four ports are allowed in a trunk by the switch. Notice that one of the links shows Standby status, while the remaining four links are “Up”.

```

ProCurve> show lacp

```

		LACP					
		PORT	LACP	TRUNK	PORT	LACP	LACP
		NUMB	ENABLED	GROUP	STATUS	PARTNER	STATUS
		----	-----	-----	-----	-----	-----
"Up" Links	→	A1	Active	Dyn1	Up	Yes	Success
	→	A2	Active	Dyn1	Up	Yes	Success
	→	A3	Active	Dyn1	Up	Yes	Success
	→	A4	Active	Dyn1	Up	Yes	Success
Standby Link	→	A5	Active	Dyn1	Standby	Yes	Success

Figure 12-9. Example of a Dynamic LACP Trunk with One Standby Link

Using the CLI To Configure a Static or Dynamic Trunk Group

Important

Configure port trunking *before* you connect the trunked links between switches. Otherwise, a broadcast storm could occur. (If you need to connect the ports before configuring them for trunking, you can temporarily disable the ports until the trunk is configured. See “Using the CLI To Configure Ports” on page 10-10.)

On the 2600, 2600-PWR, 4100gl and 6108 switches covered by this guide you can configure up to six port trunk groups having up to four links each (with additional standby links if you’re using dynamic LACP). On the 2800 switches covered by this guide you can configure up to 24 port trunk groups having up to 8 links each (with additional standby links if you’re using dynamic LACP). You can configure trunk group types as follows:

Trunk Type	Trunk Group Membership	
	TrkX (Static)	DynX (Dynamic)
LACP	Yes	Yes
Trunk	Yes	No

Note

Trunks configured as FEC (Fast Ethernet Channel) are not supported. To configure port trunk groups, use static or LACP trunks. For release notes describing the latest software updates, visit the ProCurve Networking website at <http://www.procurve.com>. Click on **Technical support**, and then click on **Product manuals**.

The following examples show how to create different types of trunk groups.

Configuring a Static Trunk or Static LACP Trunk Group.

For 2600, 2600-PWR, 4100gl, and 6108 switches:

Syntax: trunk <port-list> <trk1 | trk2 | trk3 | trk4 | trk5 | trk6 > <trunk | lacp >

For 2800 switches:

Syntax: trunk <port-list> <trk1 ... trk24 > <trunk | lacp >

The following example uses ports C4 - C6 to create a non-protocol static trunk group with the group name of **Trk2**.

```
ProCurve(config)# trunk c4-c6 trk2 trunk
```

Removing Ports from a Static Trunk Group. This command removes one or more ports from an existing **Trkx** trunk group.

Caution

Removing a port from a trunk can result in a loop and cause a broadcast storm. When you remove a port from a trunk where STP is not in use, HP recommends that you first disable the port or disconnect the link on that port.

Syntax: no trunk <port-list >

This example removes ports C4 and C5 from an existing trunk group.

```
ProCurve(config)# no trunk c4-c5
```

Enabling a Dynamic LACP Trunk Group. In the default port configuration, all ports on the switch are set to LACP **Passive**. However, to enable the switch to automatically form a trunk group that is dynamic on both ends of the link, the ports on one end of a set of links must be LACP **Active**. The ports on the other end can be either LACP **Active** or LACP **Passive**. This command enables the switch to automatically establish a dynamic LACP trunk group when the device ports on the other end of the link are configured for LACP **Passive**.

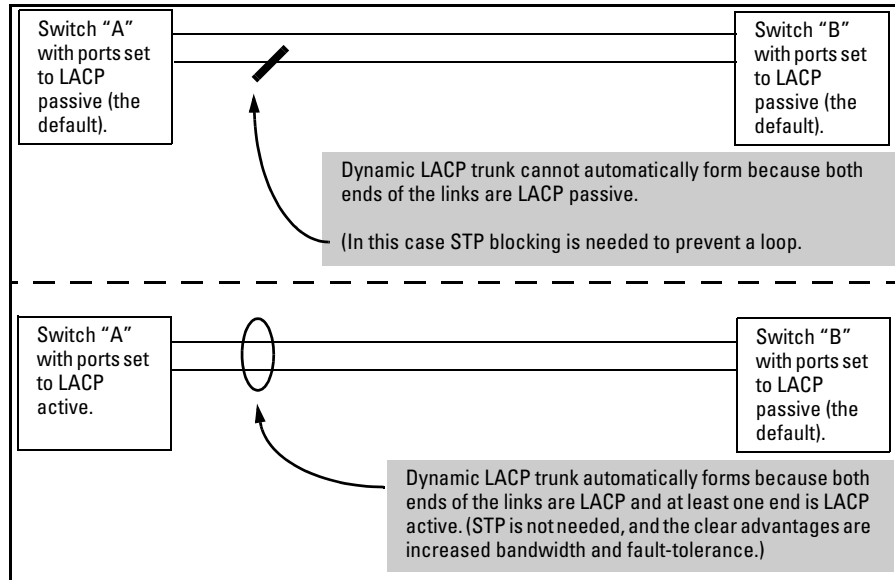

Figure 12-10. Example of Criteria for Automatically Forming a Dynamic LACP Trunk

Syntax: interface < port-list > lACP active

This example uses ports C4 and C5 to enable a dynamic LACP trunk group.

```
ProCurve(config)# interface c4-c5 lACP active
```

Removing Ports from a Dynamic LACP Trunk Group. To remove a port from dynamic LACP trunk operation, you must turn off LACP on the port. (On a port in an operating, dynamic LACP trunk, you cannot change between LACP **Active** and LACP **passive** without first removing LACP operation from the port.)

Caution

Unless STP is running on your network, removing a port from a trunk can result in a loop. To help prevent a broadcast storm when you remove a port from a trunk where STP is not in use, HP recommends that you first disable the port or disconnect the link on that port.

Syntax: no interface <port-list> lacp

In this example, port C6 belongs to an operating, dynamic LACP trunk. To remove port C6 from the dynamic trunk and return it to passive LACP, you would do the following:

```
ProCurve>(config)# no interface c6 lacp  
ProCurve>(config)# interface c6 lacp passive
```

Note that in the above example, if the port on the other end of the link is configured for active LACP or static LACP, the trunked link will be re-established almost immediately.

Web: Viewing Existing Port Trunk Groups

While the web browser interface does not enable you to configure a port trunk group, it does provide a view of an existing trunk group.

To view any port trunk groups:

Click on the **Status** tab.

Click on **Port Status**.

Trunk Group Operation Using LACP

The switch can automatically configure a dynamic LACP trunk group or you can manually configure a static LACP trunk group.

Note

LACP requires full-duplex (FDx) links of the same media type (10/100Base-T, 100FX, etc.) and the same speed, and enforces speed and duplex conformance across a trunk group.

LACP trunk status commands include:

Trunk Display Method	Static LACP Trunk	Dynamic LACP Trunk
CLI show lacp command	Included in listing.	Included in listing.
CLI show trunk command	Included in listing.	Not included.
Port/Trunk Settings screen in menu interface	Included in listing.	Not included

Thus, to display a listing of dynamic LACP trunk ports, you must use the **show lacp** command.

Note

Dynamic LACP trunks operate only in the default VLAN (unless GVRP is enabled and **Forbid** is used to prevent the trunked ports from joining the default VLAN). Thus, if an LACP dynamic trunk forms using ports that are not in the default VLAN, the trunk will automatically move to the default VLAN unless GVRP operation is configured to prevent this from occurring. In some cases, this can create a traffic loop in your network. For more on this topic, refer to “VLANs and Dynamic LACP” on page 12-24.

In most cases, trunks configured for LACP operate as described in table 12-4 on the next page.

Table 12-4. LACP Trunk Types

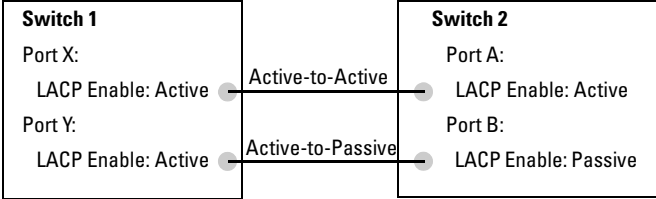
LACP Port Trunk Configuration	Operation
Dynamic LACP	<p>This option automatically establishes an 802.3ad-compliant trunk group, with LACP for the port Type parameter and DynX for the port Group name, where X is an automatically assigned value from 1 to 6 (2600, 2600-PWR, 4100gl, and 6108) or 1 to 24 (2800), depending on how many dynamic and static trunks are currently on the switch. (The 2600, 2600-PWR, 4100gl, and 6108 switches allow a maximum of six trunk groups in any combination of static and dynamic trunks; the 2800 switch allows a maximum of 24 trunk groups in any combination of static and dynamic trunks.)</p> <p>Under the following conditions, the switch automatically establishes a dynamic LACP port trunk group and assigns a port Group name:</p> <ul style="list-style-type: none"> • The ports on both ends of a link have compatible mode settings (speed and duplex). • The port on one end of a link must be configured for LACP Active and the port on the other end of the same link must be configured for either LACP Passive (the default) or LACP Active. For example:
 <pre> graph LR subgraph Switch1 [Switch 1] direction TB P1[Port X: LACP Enable: Active] P2[Port Y: LACP Enable: Active] end subgraph Switch2 [Switch 2] direction TB P3[Port A: LACP Enable: Active] P4[Port B: LACP Enable: Passive] end P1 --- Active-to-Active P3 P2 --- Active-to-Passive P4 </pre>	
<p>Either of the above link configurations allow a dynamic LACP trunk link.</p> <p>Standby Links: A maximum of four (2600, 2600-PWR, 4100gl, and 6108) or eight (2800) operating links are allowed in the trunk, but, with dynamic LACP, you can configure one or more backup links that the switch automatically activates if a primary link fails. To configure a link as a standby for an existing dynamic LACP trunk, ensure that the ports in the standby link are configured the same as either of the above examples.</p> <p>Displaying Dynamic LACP Trunk Data: To list the configuration and status for a dynamic LACP trunk, use the CLI show lacp command.</p>	
<p>Note: The dynamic trunk is automatically created by the switch, and is not listed in the static trunk listings available in the menu interface or in the CLI show trunk listing.</p>	
Static LACP	<p>The trunk operates if the trunk group on the opposite device is running one of the following trunking protocols:</p> <ul style="list-style-type: none"> • Active LACP • Passive LACP • Trunk <p>This option uses LACP for the port Type parameter and TrkX for the port Group parameter, where X is an automatically assigned value from 1 to 6 (2600, 2600-PWR, 4100gl, and 6108) or 1 to 24 (2800), depending on how many static trunks are currently operating on the switch. (The switch allows the maximum number of trunk groups in any combination of static and dynamic trunks.)</p> <p>Displaying Static LACP Trunk Data: To list the configuration and status for a static LACP trunk, use the CLI show lacp command. To list a static LACP trunk with its assigned ports, use the CLI show trunk command or display the menu interface Port/Trunk Settings screen.</p> <p>Static LACP does not allow standby ports.</p>

Default Port Operation

In the default configuration, all ports are configured for passive LACP. However, if LACP is not configured, the port will not try to detect a trunk configuration and will operate as a standard, untrunked port.

Note

Passive and active LACP port will pause and listen for LACP packets once a link is established. Once this pause is complete then the port, if a trunk is not detected, will be placed in forwarding mode. Some end-node applications have been found to be sensitive to this pause and may require LACP to be disabled on the port.

The following table describes the elements of per-port LACP operation. To display this data for a particular switch, execute the following command in the CLI:

```
ProCurve> show lacp
```

Table 12-5. LACP Port Status Data

Status Name	Meaning
Port Numbr	Shows the physical port number for each port configured for LACP operation (C1, C2, C3 . . .). Unlisted port numbers indicate that the missing ports are assigned to a static Trunk group or are not configured for any trunking.
LACP Enabled	Active: The port automatically sends LACP protocol packets. Passive: The port does not automatically send LACP protocol packets, and responds only if it receives LACP protocol packets from the opposite device. A link having either two active LACP ports or one active port and one passive port can perform dynamic LACP trunking. A link having two passive LACP ports will not perform LACP trunking because both ports are waiting for an LACP protocol packet from the opposite device. Note: In the default switch configuration, all ports are configured for passive LACP operation.
Trunk Group	TrkX: This port has been manually configured into a static LACP trunk. Trunk Group Same as Port Number: The port is configured for LACP, but is not a member of a port trunk.
Port Status	Up: The port has an active LACP link and is not blocked or in Standby mode. Down: The port is enabled, but an LACP link is not established. This can indicate, for example, a port that is not connected to the network or a speed mismatch between a pair of linked ports. Disabled: The port cannot carry traffic. Blocked: LACP, or STP has blocked the port. (The port is not in LACP Standby mode.) This may be due to a trunk negotiation (very brief) or a configuration error such as differing port speeds on the same link or attempting to connect the switch to more than the maximum number of supported trunks. Standby: The port is configured for dynamic LACP trunking to another device, but the maximum number of ports for the Dynamic trunk to that device has already been reached on either the switch itself or the other device. This port will remain in reserve, or “standby” unless LACP detects that another, active link in the trunk has become disabled, blocked, or down. In this case, LACP automatically assigns a Standby port, if available, to replace the failed port.
LACP Partner	Yes: LACP is enabled on both ends of the link. No: LACP is enabled on the switch, but either LACP is not enabled or the link has not been detected on the opposite device.
LACP Status	Success: LACP is enabled on the port, detects and synchronizes with a device on the other end of the link, and can move traffic across the link. Failure: LACP is enabled on a port and detects a device on the other end of the link, but is not able to synchronize with this device, and therefore not able to send LACP packets across the link. This can be caused, for example, by an intervening device on the link (such as a hub), a bad hardware connection, or if the LACP operation on the opposite device does not comply with the IEEE 802.3ad standard.

LACP Notes and Restrictions

802.1X (Port-Based Access Control) Configured on a Port. To maintain security, LACP is not allowed on ports configured for 802.1X authenticator operation. If you configure port security on a port on which LACP (active or passive) is configured, the switch removes the LACP configuration, displays a notice that LACP is disabled on the port(s), and enables 802.1X on that port.

```
ProCurve(config)# aaa port-access authenticator e b1
LACP has been disabled on 802.1X port(s).
```

The switch will not allow you to configure LACP on a port on which port access (802.1X) is enabled. For example:

```
ProCurve(config)# int b1 lacp passive
Error configuring port < port-number >: LACP and 802.1X cannot be run
together.
```

To restore LACP to the port, you must first remove the port's 802.1X configuration and then re-enable LACP active or passive on the port.

Port Security Configured on a Port. To maintain security, LACP is not allowed on ports configured for port security. If you configure port security on a port on which LACP (active or passive) is configured, the switch removes the LACP configuration, displays a notice that LACP is disabled on the port(s), and enables port security on that port. For example:

```
ProCurve(config)# port-security a17 learn-mode static address-limit 2
LACP has been disabled on secured port(s).
```

The switch will not allow you to configure LACP on a port on which port security is enabled. For example:

```
ProCurve(config)# int a17 lacp passive
Error configuring port A17: LACP and port security cannot be run together.
```

To restore LACP to the port, you must remove port security and re-enable LACP active or passive.

Changing Trunking Methods. To convert a trunk from static to dynamic, you must first eliminate the static trunk.

Static LACP Trunks. Where a port is configured for LACP (Active or Passive), but does not belong to an existing trunk group, you can add that port to a static trunk. Doing so disables dynamic LACP on that port, which means you must manually configure both ends of the trunk.

Dynamic LACP Trunks. You can configure a port for LACP-active or LACP-passive, but on a dynamic LACP trunk you cannot configure the other options that you can on static trunks. If you want to manually configure a trunk, use the **trunk** command. (Refer to “Using the CLI To Configure a Static or Dynamic Trunk Group” on page 12-15.)

VLANs and Dynamic LACP. A dynamic LACP trunk operates only in the default VLAN (unless you have enabled GVRP on the switch and use **Forbid** to prevent the ports from joining the default VLAN).

- If you want to use LACP for a trunk on a non-default VLAN and GVRP is disabled, configure the trunk as a static trunk.
- If there are ports that you do not want on the default VLAN, ensure that they cannot become dynamic LACP trunk members. Otherwise a traffic loop can unexpectedly occur. For example:

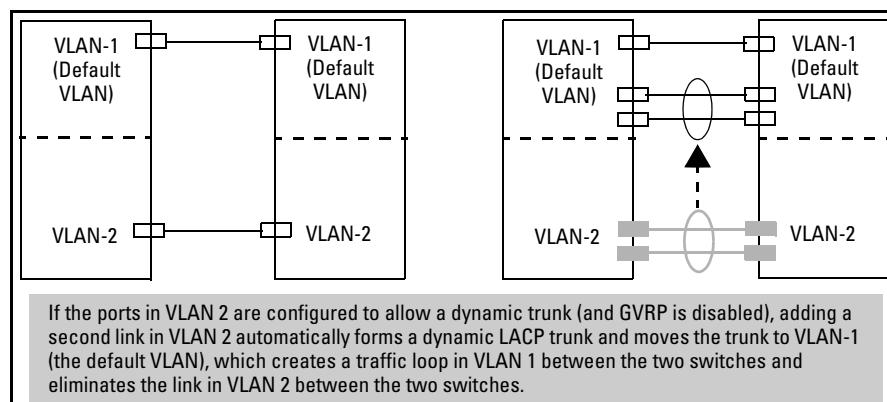

Figure 12-11. A Dynamic LACP Trunk Forming in a VLAN Can Cause a Traffic Loop

Easy control methods include either disabling LACP on the selected ports or configuring them to operate in static LACP trunks.

STP and IGMP. If spanning tree (STP) and/or IGMP is enabled in the switch, a dynamic LACP trunk operates only with the default settings for these features and does not appear in the port listings for these features.

Half-Duplex and/or Different Port Speeds Not Allowed in LACP

Trunks. The ports on both sides of an LACP trunk must be configured for the same speed and for full-duplex (FDx). The 802.3ad LACP standard specifies a full-duplex (FDx) requirement for LACP trunking.

A port configured as LACP passive and not assigned to a port trunk can be configured to half-duplex (HDx). However, in any of the following cases, a port cannot be reconfigured to an HDx setting:

- If a port is set to LACP Active, you cannot configure it to HDx.
- If a port is already a member of a static or dynamic LACP trunk, you cannot configure it to HDx.
- If a port is already set to HDx, the switch does not allow you to configure it for a static or dynamic LACP trunk.

Dynamic/Static LACP Interoperation: A port configured for dynamic LACP can properly interoperate with a port configured for static (TrkX) LACP, but any ports configured as standby LACP links will be ignored.

Trunk Group Operation Using the “Trunk” Option

This method creates a trunk group that operates independently of specific trunking protocols and does not use a protocol exchange with the device on the other end of the trunk. With this choice, the switch simply uses the SA/DA method of distributing outbound traffic across the trunked ports without regard for how that traffic is handled by the device at the other end of the trunked links. Similarly, the switch handles incoming traffic from the trunked links as if it were from a trunked source.

Use the Trunk option when you are trying to establish a trunk group between the switch and another device, but the other device’s trunking operation fails to interoperate properly with LACP trunking configured on the switch itself.

How the Switch Lists Trunk Data

Static Trunk Group: Appears in the menu interface and the output from the CLI **show trunk** and **show interfaces** commands.

Dynamic LACP Trunk Group: Appears in the output from the CLI **show lacp** command.

Interface Option	Dynamic LACP Trunk Group	Static LACP Trunk Group	Static Non-Protocol Trunk Group
Menu Interface	No	Yes	Yes
CLI:			
show trunk	No	Yes	Yes
show interfaces	No	Yes	Yes
show lacp	Yes	Yes	No
show spanning-tree	No	Yes	Yes
show igmp	No	Yes	Yes
show config	No	Yes	Yes

Outbound Traffic Distribution Across Trunked Links

Both trunk group options (LACP and Trunk) use source-destination address pairs (SA/DA) for distributing outbound traffic over trunked links.

SA/DA (source address/destination address) causes the switch to distribute outbound traffic to the links within the trunk group on the basis of source/destination address pairs. That is, the switch sends traffic from the same source address to the same destination address through the same trunked link, and sends traffic from the same source address to a different destination address through a different link, depending on the rotation of path assignments among the links in the trunk. Likewise, the switch distributes traffic for the same destination address but from different source addresses through different links. Because the amount of traffic coming from or going to various nodes in a network can vary widely, it is possible for one link in a trunk group to be fully utilized while others in the same trunk have unused bandwidth capacity even though the address assignments are evenly distributed across the links in a trunk. In actual networking environments, this is rarely a problem. However, if it becomes a problem, you can use the ProCurve Manager Plus network management software to quickly and easily identify the sources of heavy traffic (top talkers) and make adjustments to improve performance.

Broadcasts, multicasts, and floods from different source addresses are distributed evenly across the links. As links are added or deleted, the switch redistributes traffic across the trunk group. For example, in figure 12-12 showing a three-port trunk, traffic could be assigned as shown in table 12-6.

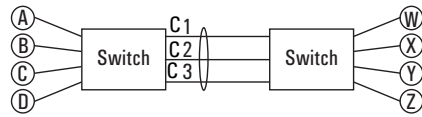

Figure 12-12. Example of Port-Trunked Network

Table 12-6. Example of Link Assignments in a Trunk Group (SA/DA Distribution)

Source:	Destination:	Link:
Node A	Node W	1
Node B	Node X	2
Node C	Node Y	3
Node D	Node Z	1
Node A	Node Y	2
Node B	Node W	3

— This page is intentionally unused. —