

HP ProCurve Switch 2600 Series

Installation and Getting Started Guide

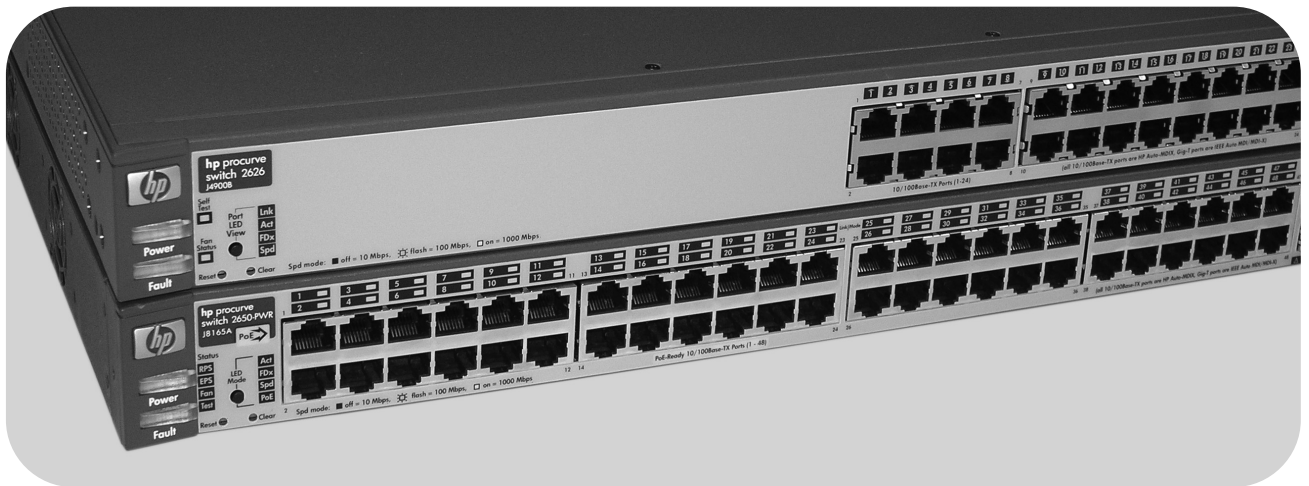

Power over Ethernet Devices

www.hp.com/go/hpprocurve

HP ProCurve switch 2600 and 2600-PWR Series

Installation and Getting Started Guide

© Copyright 2004 Hewlett-Packard Development Company, L.P. The information contained herein is subject to change without notice.

This document contains proprietary information, which is protected by copyright. No part of this document may be photocopied, reproduced, or translation into another language without the prior written consent of Hewlett-Packard.

Publication Number

5990-8821
September 2004

Applicable Products

HP ProCurve Switch 2626-PWR	(J8164A)
HP ProCurve Switch 2650-PWR	(J8165A)
HP ProCurve 600 Redundant and External Power Supply	(J8168A)
HP ProCurve 610 External Power Supply	(J8169A)
HP ProCurve Switch 2626	(J4900B)
HP ProCurve Switch 2650	(J4899B)

Trademark Credits

Windows NT®, Windows®, and MS Windows® are US registered trademarks of Microsoft Corporation.

Disclaimer

HEWLETT-PACKARD COMPANY MAKES NO WARRANTY OF ANY KIND WITH REGARD TO THIS MATERIAL, INCLUDING, BUT NOT LIMITED TO, THE IMPLIED WARRANTIES OF MERCHANTABILITY AND FITNESS FOR A PARTICULAR PURPOSE. Hewlett-Packard shall not be liable for errors contained herein or for incidental or consequential damages in connection with the furnishing, performance, or use of this material.

The only warranties for HP products and services are set forth in the express warranty statements accompanying such products and services. Nothing herein should be construed as constituting an additional warranty. HP shall not be liable for technical or editorial errors or omissions contained herein.

Hewlett-Packard assumes no responsibility for the use or reliability of its software on equipment that is not furnished by Hewlett-Packard.

Warranty

See the Customer Support/Warranty booklet included with the product.

A copy of the specific warranty terms applicable to your Hewlett-Packard products and replacement parts can be obtained from your HP Sales and Service Office or authorized dealer.

Contents

1 Introducing the Switch

Front of the Switch	1-3
Network Ports	1-4
LEDs	1-4
Port LEDs	1-6
Multiple-Display Port LEDs - Port LED View or LED Mode Select Button and Indicator LEDs	1-7
Reset Button	1-9
Clear Button	1-9
Back of the Switch	1-10
Console Port	1-10
Power Connector	1-10
Switch Features	1-11

2 Installing the Switch

Included Parts	2-1
Installation Procedures	2-3
Installation Precautions:	2-4
1. Prepare the Installation Site	2-5
2. Installing or Removing mini-GBICs	2-7
3. Verify the Switch Passes Self Test	2-9
LED Behavior:	2-10
4. Mount the Switch	2-11
Rack or Cabinet Mounting	2-11
Rack Mounting the 2626-PWR and 2650-PWR switches	2-12
Rack Mounting the Non-PWR Switches	2-14
Flat Wall Mounting	2-15
Horizontal Surface Mounting	2-17
5. Connect the Switch to a Power Source	2-17
6. Connect the Network Cables	2-18
Using the RJ-45 Connectors	2-18
Connecting Cables to mini-GBICs	2-18

7. (Optional) Connect a Redundant Power Supply to a	
Switch 2600-PWR Series	2-19
RPS/EPS Operation	2-19
Operating Characteristics of the HP 600 RPS/EPS (J8168A) . . .	2-19
HP 600 RPS/EPS LEDs	2-20
HP 610 EPS LEDs	2-25
Operating Characteristics of the HP 610 EPS (J8169A)	2-25
8. (Optional) Connect a Console to the Switch	2-28
Terminal Configuration	2-28
Direct Console Access	2-29
Sample Network Topologies for Non-PWR Switches	2-30
As a Desktop Switch	2-30
As a Segment Switch	2-31
Connecting to a Backbone Switch	2-33
Sample Network Topologies for PWR Switches	2-34
As a Desktop Switch Implementing PoE	2-34
As a Segment Switch Implementing PoE	2-35
Stacking the Switch	2-37

3 Configuring the Switch

Recommended Minimal Configuration	3-1
Using the Console Setup Screen	3-2
Where to Go From Here	3-4
Using the IP Address for Remote Switch Management	3-5
Starting a Telnet Session	3-5
Starting a Web Browser Session	3-5

4 Troubleshooting

Basic Troubleshooting Tips	4-1
Diagnosing with the LEDs	4-4
Proactive Networking	4-8
Hardware Diagnostic Tests	4-9
Testing the Switch by Resetting It	4-9
Checking the Switch LEDs	4-9
Checking Console Messages	4-9
Testing Twisted-Pair Cabling	4-10

Testing Switch-to-Device Network Communications	4-10
Testing End-to-End Network Communications	4-10
Restoring the Factory Default Configuration	4-11
Downloading New Switch Software	4-12
HP Customer Support Services	4-12
Before Calling Support	4-12

A Switch Specifications

Physical	A-1
Electrical	A-1
Environmental	A-1
Acoustic	A-2
Connectors	A-2
Safety	A-2
Lasers	A-2

B Switch Ports and Network Cables

Switch Ports	B-1
Twisted-Pair Cables	B-1
Fiber-Optic Cables	B-2
Mode Conditioning Patch Cord for Gigabit-LX	B-3
Installing the Patch Cord	B-4
Recommended Patch Cords	B-4
Twisted-Pair Cable/Connector Pin-Outs	B-5
Straight-Through Twisted-Pair Cable for	
10 Mbps or 100 Mbps Network Connections	B-7
Cable Diagram	B-7
Pin Assignments	B-7
Crossover Twisted-Pair Cable for	
10 Mbps or 100 Mbps Network Connection	B-8
Cable Diagram	B-8
Pin Assignments	B-8
Straight-Through Twisted-Pair Cable for 1000 Mbps	
Network Connections	B-9
Cable Diagram	B-9
Pin Assignments	B-9

C Safety and EMC Regulatory Statements

Safety Information	C-1
Informations concernant la sécurité	C-2
Hinweise zur Sicherheit	C-3
Considerazioni sulla sicurezza	C-4
Consideraciones sobre seguridad	C-5
Safety Information (Japan)	C-6
Safety Information (China)	C-7
EMC Regulatory Statements	C-8
U.S.A.	C-8
Canada	C-8
Australia/New Zealand	C-8
Japan	C-8
Korea	C-9
Taiwan	C-9
European Community	C-10

Index

Introducing the Switch

The HP ProCurve Switch 2600 Series devices are multiport switches that can be used to build high-performance switched workgroup networks. These switches are store-and-forward devices that offers low latency for high-speed networking. The 2600-PWR Switches also support Redundant Power Supply and Power over Ethernet (PoE) technologies.

HP ProCurve Switch 2650 (J4899B)

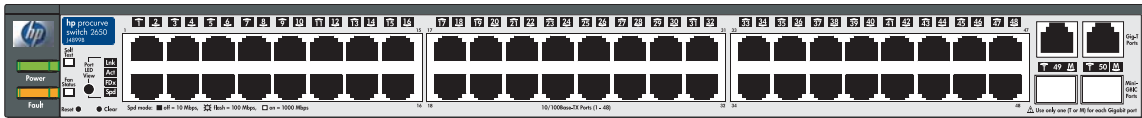

HP ProCurve Switch 2626 (J4900B)

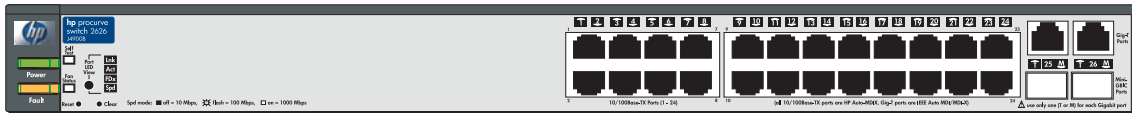

HP ProCurve Switch 2650-PWR (J8165A)

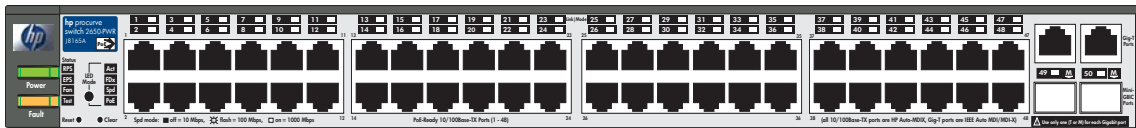

HP ProCurve Switch 2626-PWR (J8164A)

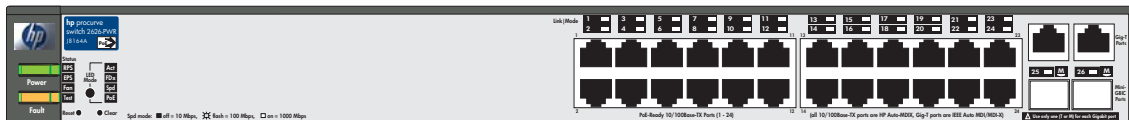

Throughout this manual, these switches will be referred to as the Switch 2600 Series and the Switch 2600-PWR Series.

The Switch 2650 and 2650-PWR, and Switch 2626 and 2626-PWR have 48 and 24 auto-sensing 10/100Base-TX RJ-45 ports, respectively, and two dual-personality ports—either auto-sensing 10/100/1000Base-T RJ-45, or mini-GBIC (SFP ports in an Ethernet application).

The Switch 2600-PWR Series devices incorporate two additional features, both having to do with power. These switches have two internal power supplies, one for switch AC operating power, and the other for Power over Ethernet (PoE) power:

- **Power-over-Ethernet or PoE power** - PoE technology allows IP telephones, wireless LAN Access Points and other appliances to receive power as well as data over existing LAN cabling, without needing to modify the existing Ethernet infrastructure. The Switch 2600-PWR Series is designed with an internal PoE power supply capable of providing 406 watts of PoE power. All of the Switch 2600-PWR ports can provide up to 15.4 watts of PoE power to connected devices. For further information regarding PoE power, see the *PoE Planning and Implementation Guide* which is on the documentation CD that came with the switch.
- **Redundant and External Power Supply Support** - The Switch 2600-PWR Series can be connected to an HP ProCurve 600 Redundant and External Power Supply (J8168A), hereafter referred to as the HP 600 RPS/EPS or an HP ProCurve 610 External Power Supply, hereafter referred to as the HP 610 EPS, and receive redundant power from that unit. As an RPS unit, the HP 600 RPS/EPS will provide all the AC power necessary to keep the switch running should the switch internal AC power supply fail.

As an EPS unit, the HP 600 RPS/EPS and the HP 610 EPS can supply up to 408 watts of PoE power to the switch if the internal PoE power supply of the switch should fail. When used with the Switch 2650-PWR, the additional EPS power can provide up to 15.4 watts per port for 48 ports. For further information regarding the HP 600 RPS/EPS or the HP 610 EPS PoE capabilities, see the *PoE Planning and Implementation Guide*, which is on the documentation CD that came with the switch.

With these switches you can directly connect computers, printers, and servers to provide dedicated bandwidth to those devices, and you can build a switched network infrastructure by connecting the switch to hubs, other switches, or routers. In addition, the Switch 2600 Series offer full network management capabilities.

This chapter describes the HP Switch 2600 and 2600-PWR Series devices including:

- Front and back of the switch
- LED patterns
- Switch features

Front of the Switch

HP ProCurve Switch 2650

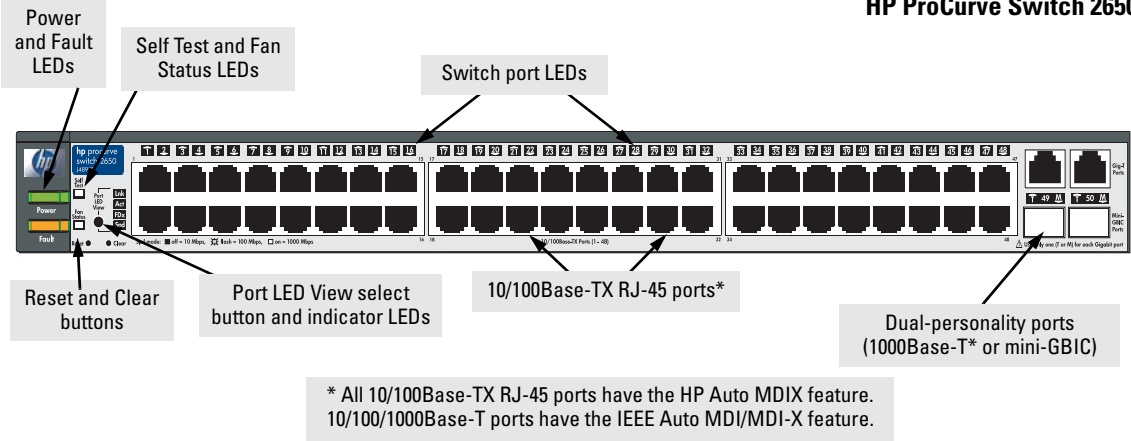

HP ProCurve Switch 2650-PWR

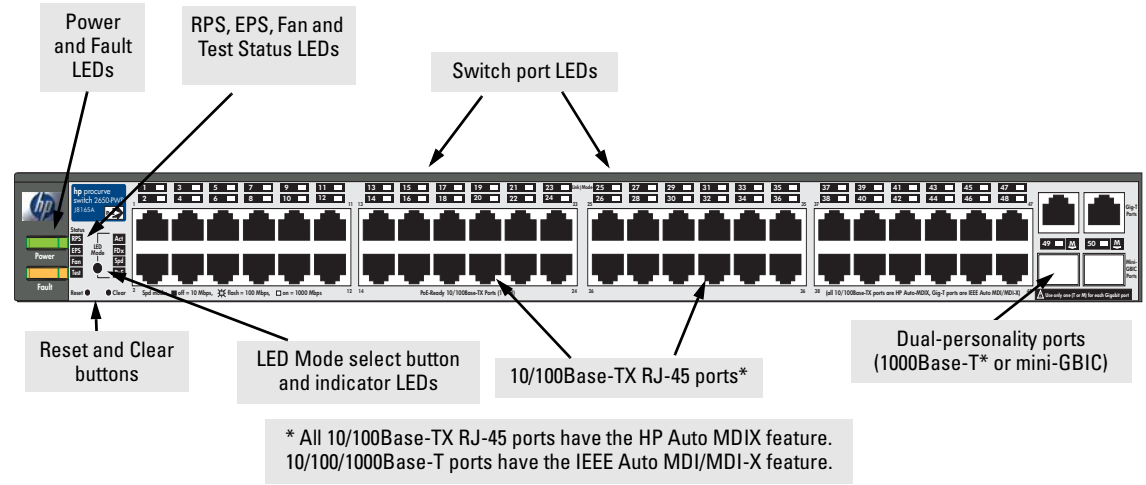

Network Ports

- 48 or 24 auto-sensing 10/100Base-TX ports.
All these ports have the “HP Auto MDIX” feature, which means that you can use either straight-through or crossover twisted-pair cables to connect any network devices to the switch.
- Two dual-personality ports. You can use either the 10/100/1000Base-T RJ-45 connector, or install a supported HP ProCurve mini-GBIC for fiber-optic connections. *The RJ-45 connectors support the IEEE Auto MDI/MDI-X feature, which operates the same as the “HP Auto-MDIX” feature.*

By default, the RJ-45 connectors are enabled. If a mini-GBIC is installed in a slot, it is enabled and the associated RJ-45 connector is disabled and cannot be used. If the mini-GBIC is removed, the associated RJ-45 port is automatically re-enabled.

LEDs

On the Switch 2600 Series devices, there are three groupings of LEDs:

- switch status LEDs (Table 1-1)
- port LEDs (Table 1-2)
- Port LED View (non-PWR switches) and LED Mode (PWR switches) indicator LEDs (near the selector button) (Table 1-3).

Table 1-1. Switch Status LEDs

Switch LEDs	State	Meaning
Power (green)	On	The switch is receiving power.
	Off	The switch is NOT receiving power.
Fault (orange)	Off	The normal state; indicates there are no fault conditions on the switch.
	Blinking*	A fault has occurred on the switch, one of the switch ports, the fan, or the RPS or EPS operation of the switch. The Status LED for the component with the fault will blink simultaneously.
	On	On briefly after the switch is powered on or reset, at the beginning of switch self test. If this LED is on for a prolonged time, the switch has encountered a fatal hardware failure, or has failed its self test. See chapter 4, “ Troubleshooting ” for more information.

Switch LEDs	State	Meaning
Self Test (green) labeled "Test" on the PWR switches	Off	The normal operational state; the switch is not undergoing self test.
	On	The switch self test and initialization are in progress after you have power cycled or reset the switch. The switch is not operational until this LED goes off. The Self Test LED also comes on briefly when you "hot swap" a mini-GBIC into the switch; the mini-GBIC is tested when it is hot swapped.
	Blinking*	A component of the switch has failed its self test. The status LED for that component, for example an RJ-45 port, and the switch Fault LED will blink simultaneously.
Fan Status (green)	On	The cooling fan is operating normally.
	Blinking*	The cooling fan has failed. The switch Fault LED will be blinking simultaneously.
RPS Status** (green)	On	Normal operation. An HP 600 RPS/EPS unit is connected and operating correctly. The HP 600 RPS/EPS could be powering the unit - see table below.
	Blinking	The HP 600 RPS/EPS is connected but may be powering another switch or the HP 600 RPS/EPS has experienced a fault.
	Off	The HP 600 RPS/EPS is not connected or is not powered.
EPS Status** (green)	On	Connected to an External Power Supply, either an HP 600 RPS/EPS or an HP 610 EPS, and receiving PoE power.
	Blinking	The External Power Supply has experienced a fault: <ul style="list-style-type: none"> • PoE power is oversubscribed (not enough PoE power available). • The software on the HP ProCurve Switch 2600-PWR Series device may not support the EPS function. • There is a fan, overcurrent, power supply, or temp fault. • The Switch detects the EPS is present but cannot communicate with it. Check the Error Log on the switch for more information.
	Off	The switch is not connected to an External Power Supply or the EPS cable is connected but the External Power Supply is not powered up.
** HP ProCurve Switch 2600-PWR Series devices only.		
* The blinking behavior is an on/off cycle once every 1.6 seconds, approximately.		

See the *HP ProCurve 600/610 External Power Supplies Installation and Getting Started Guide* for information on the LED behavior of the external power supplies.

Port LEDs

The port LEDs provide information about the individual switch ports.

Table 1-2. Port LEDs

Switch LEDs	State	Meaning
Switch 2626 and Switch 2650		
Port LEDs (green – overlaid with the port number)		Displays port link information, network activity information, whether the port is configured for full-duplex operation, or the speed of the connection depending on the Port LED View selected. See “Port LED View Select Button and Indicator LEDs” on the next page for more information.
Switch 2626-PWR and Switch 2650-PWR		
Link (green - overlaid with the port number)	On	Indicates the port is enabled and receiving a link beat signal (for the twisted-pair ports), of a strong enough light level (for the fiber-optic ports) from the connected device.
	Off	One of these condition exists: <ul style="list-style-type: none"> no active network cable is connected to the port the port is not receiving link beat or sufficient light the port has been disabled through the switch console, the web browser interface, HP ProCurve Manager, or other network management tool.
	Blinking*	The port has failed self test. The switch Fault, and Self Test LEDs will flash simultaneously.
Mode		Depending on the mode selected, displays the following: network activity information, whether the port is configured for Full Duplex operation, maximum speed operation, or whether network errors are occurring on the port. See “LED Mode Select Button and Indicator LEDs:” below for more information.
All four Switch 2600 Series devices		
T/M (green – ports 49 and 50 only)	On	For the dual-personality ports, indicates the enabled port: <ul style="list-style-type: none"> if the “T” is on, the 10/100/1000Base-T RJ-45 port is enabled. if the “M” is on, the mini-GBIC port is enabled.
* The blinking behavior is an on/off cycle once every 1.6 seconds, approximately.		

Multiple-Display Port LEDs - Port LED View or LED Mode Select Button and Indicator LEDs

To optimize the amount of information that can be displayed for each of the switch ports in the limited space available, the Switch 2600 Series devices use multiple-display LEDs for each port.

Switch 2626 and Switch 2650

For the non-PWR switches, there is a single LED per port. The operation of this LED is controlled by the Port LED View select button, and the current setting is indicated by the Port LED View indicator LEDs near the button. Press the button to step from one view mode to the next. The default view is Link (Lnk).

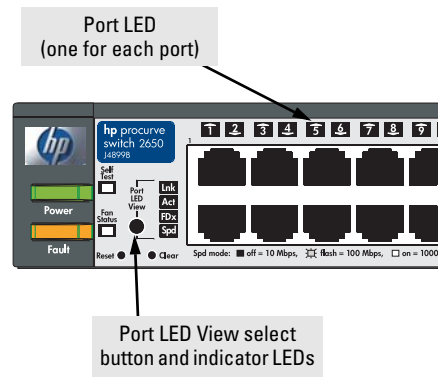

Switch 2626-PWR and 2650-PWR

For the PWR switches, there are two LEDs per port. The Link status is always shown by the Link LED. The operation of the Mode LED is controlled by the LED Mode select button, and the current setting is indicated by the LED Mode indicator LEDs near the button. Press the button to step from one view mode to the next. The default view is Activity (Act).

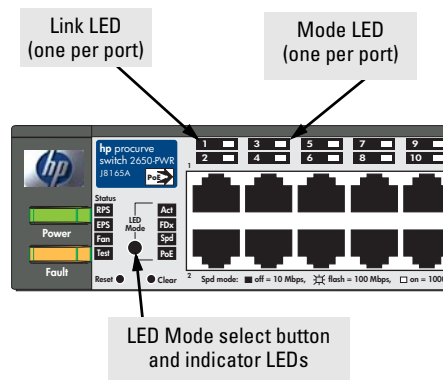

Table 1-3. Multiple-Display Port LEDs

Switch LEDs	State	Meaning
Switch 2626 and Switch 2650		
Port LED View indicator LEDs (4 green LEDs)	Lnk	Indicates that the Port LEDs are displaying link information: <ul style="list-style-type: none"> • if the Port LED is on, the port is enabled and receiving a link indication from the connected device. • if the Port LED is off, the port has no active network cable connected, or is not receiving signal or sufficient light. Otherwise, the port may have been disabled through the switch console or the web browser interface. • if the Port LED is blinking* simultaneously with the Fault LED, the corresponding port has failed its self test.
	Act	Indicates the Port LEDs are displaying network activity information.
	FDx	Indicates the Port LEDs are lit for ports that are in full-duplex mode.
	Spd	Indicates the Port LEDs are displaying the connection speed at which each port is operating: <ul style="list-style-type: none"> • if the Port LED is off, the port is operating at 10 Mbps. • if the Port LED is flashing, the port is operating at 100 Mbps. • if the Port LED is on continuously, the port is operating at 1000 Mbps.
Switch 2626-PWR and Switch 2650-PWR		
LED Mode indicator LEDs (4 green LEDs)	Act	Indicates the Port Mode LEDs are displaying network activity information.
	FDx	Indicates the Port Mode LEDs are lit for ports that are in full-duplex mode.
	Spd	Indicates the Port Mode LEDs are displaying the connection speed at which each port is operating: <ul style="list-style-type: none"> • if the Port LED is off, the port is operating at 10 Mbps. • if the Port LED is flashing, the port is operating at 100 Mbps. • if the Port LED is on continuously, the port is operating at 1000 Mbps.
	PoE	Indicates the Port Mode LEDs are lit for ports that are providing PoE power to the connected device.
* The blinking behavior is an on/off cycle once every 1.6 seconds, approximately.		

Reset Button

This button is used to reset the switch while it is powered on. This action clears any temporary error conditions that may have occurred and executes the switch self test.

Clear Button

This button is used for these purposes:

- **Deleting Passwords** - When pressed by itself for at least one second, the button deletes any switch console access passwords that you may have configured. Use this feature if you have misplaced the password and need console access.

This button is provided for your convenience, but its presence means that if you are concerned with the security of the switch configuration and operation, you should make sure the switch is installed in a secure location, such as a locked wiring closet.

- **Restoring Factory Default Configuration** - When pressed with the Reset button in a specific pattern, any configuration changes you may have made through the switch console, the web browser interface, and SNMP management are removed, and the factory default configuration is restored to the switch. For the specific method to restore the factory default configuration, see [“Restoring the Factory Default Configuration” on page 11](#), “Troubleshooting” of this manual.

Back of the Switch

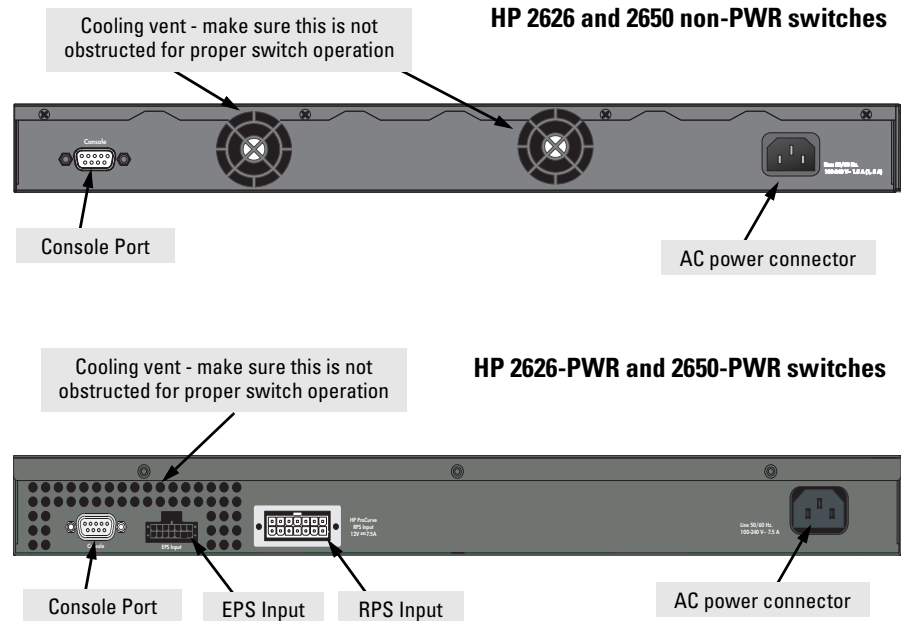

Console Port

This port is used to connect a console to a Switch 2600 Series device by using the serial cable supplied with each switch. This connection is described under [“8. \(Optional\) Connect a Console to the Switch”](#) on page 28 in chapter 2, “Installing the Switch 2600 Series.” The console can be a PC or workstation running a VT-100 terminal emulator, or a VT-100 terminal.

Power Connector

The Switch 2600 Series devices do not have a power switch; they are powered on when connected to an active AC power source. The switches automatically adjust to any voltage between 100–240 volts and either 50 or 60 Hz. There are no voltage range settings required.

Switch Features

The features of the Switch 2600 Series devices include:

- 48 or 24 auto-sensing 10/100Base-TX RJ-45 ports with HP Auto-MDIX.
- two dual-personality ports—either the auto sensing 10/100/1000Base-T RJ-45 or the mini-GBIC can be used for each port.
- Power over Ethernet (PoE) operation—the Switch 2626-PWR and the Switch 2650-PWR are IEEE 802.3af compliant and provide up to 15.4W per port to power IP phones, wireless access points, web cameras, and more. For more information, see the *POE Planning and Implementation Guide*, which is on the Documentation CD-ROM that is included with your switch.
- plug-and-play networking—all ports are enabled—just connect the network cables to active network devices and your switched network is operational.
- HP Auto-MDIX on all 10/100 twisted-pair ports, and IEEE 802.3ab Auto MDI/MDI-X on all 10/100/1000 twisted-pair ports, meaning that **all twisted-pair connections can be made using straight-through cables**. Cross-over cables are not required, although they will also work.
- automatic learning of the network addresses in each switch's 8000-address forwarding table, (with configurable address aging value).
- automatically negotiated full-duplex operation for the 10/100 and 10/100/1000 RJ-45 ports when connected to other auto-negotiating devices—the mini-GBIC ports always operate at full duplex.
- easy management of the switches through several available interfaces:
 - **console interface**—a full featured, easy to use, VT-100 terminal interface that is especially good for out-of-band switch management or for Telnet access to the switch.
 - **web browser interface**—an easy to use built-in graphical interface that can be accessed from common web browsers.
 - **HP ProCurve Manager**—an SNMP-based, graphical network management tool that you can use to manage your entire network.
- support for the Spanning Tree Protocol to eliminate network loops
- support for up to 30 IEEE 802.1Q-compliant VLANs so you can divide the attached end nodes into logical groupings that fit your business needs.
- support for many advanced features to enhance network performance—for a description, see the *Management and Configuration Guide*, which is on the Documentation CD-ROM that is included with your switch.
- download of new switch software for product enhancements or bug fixes.

— *This page is intentionally unused.* —

Installing the Switch

The HP Switch 2600 Series devices come with an accessory kit that includes the brackets for mounting the switch in a standard 19-inch telco rack, in an equipment cabinet, or on a wall. The brackets are designed to allow mounting the switch in a variety of locations and orientations. Rubber feet are provided that can be attached so the switch can be securely located on a horizontal surface.

This chapter shows you how to install your Switch 2600 Series devices.

Included Parts

The Switch 2600 Series devices have the following components shipped with them:

- *HP ProCurve Switch 2600 Series Installation and Getting Started Guide* (5990-8821), this manual
- *HP ProCurve Product Documentation CD ROM* (contains PDF file copies of the documentation for the Switch 2600 Series, including the *Management and Configuration Guide*, and documentation for most other HP ProCurve switches)
- *HP ProCurve Manager* - CD ROM and booklet
- Console cable
- Customer Support/Warranty booklet
- Accessory kits

(5069-6535) for Switches 2626 and 2650

(5069-5705) for Switches 2626-PWR and 2650-PWR

two mounting brackets

two mounting brackets*

four 8-mm M4 screws to attach the mounting brackets to the switch

eight 8-mm M4 screws to attach the mounting brackets to the switch

four 5/8-inch number 12-24 screws to attach the switch to a rack

four 5/8-inch number 12-24 screws to attach the switch to a rack

four rubber feet

four rubber feet

* The mounting brackets differ from the 5069-6535 mounting brackets by being longer to support the increased depth of the PWR products (compared to the non-PWR products).

- AC power cord, one of the following:

Country	Non-PWR Switches	PWR Switches*
Australia/New Zealand	8120-6803	8120-6810
China	8120-8377	8120-8471
Continental Europe	8120-6802	8120-6811
Denmark	8120-6806	8120-6814
Japan	8120-6804	8120-6804
Switzerland	8120-6807	8120-6815
United Kingdom/Hong Kong/Singapore	8120-8709	8120-6809
United States/Canada/Mexico	8120-6805	8120-2371

* The cords for the PWR Switches support a higher amperage.

Installation Procedures

These steps summarize your switch installation. The rest of this chapter provides details on these steps.

1. **Prepare the installation site (page 2-5).** Make sure the physical environment into which you will be installing the switch is properly prepared, including having the correct network cabling ready to connect to the switch and having an appropriate location for the switch. *Please see page 2-4 for some installation precautions.*
2. **Install mini-GBICs (optional—page 2-7).** The switch has two slots for installing mini-GBICs. Depending on where you install the switch, it may be easier to install the mini-GBICs first. Mini-GBICs can be hot swapped—they can be installed or removed while the switch is powered on.
3. **Verify the switch passes self test (page 2-9).** Plug the switch into a power source and observe that the LEDs on the switch's front panel indicate correct switch operation.
4. **Mount the switch (page 2-11).** The Switch 2600 Series can be mounted in a 19-inch telco rack, in an equipment cabinet, on a wall, or on a horizontal surface. The Switch 2600-PWR Series devices may be mounted in the above racks and cabinets or on a horizontal surface. The Switch 2600-PWR Series devices must not be wall mounted.
5. **Connect power to the switch (page 2-17).** Once the switch is mounted, plug it into the main power source.
6. **Connect the network devices (page 2-18).** Using the appropriate network cables, connect the network devices to the switch ports.
7. **Connect an HP 600 RPS/EPS or HP 610 EPS, (optional—page 2-19).** You may wish to use an HP 600 RPS/EPS or HP 610 EPS with your Switch 2626-PWR or Switch 2650-PWR. To do so you must connect these external power supplies using the RPS or EPS cables supplied with these devices.
8. **Connect a console to the switch (optional—page 2-28).** You may wish to modify the switch's configuration, for example, to configure an IP address so it can be managed using a web browser, from an SNMP network management station, or through a Telnet session. Configuration changes can be made by using the included console cable to connect a PC to the switch's console port.

At this point, your switch is fully installed. See the rest of this chapter if you need more detailed information on any of these installation steps.

Installation Precautions:

Follow these precautions when installing your HP Switch 2600 Series.

WARNING

- **The rack or cabinet should be adequately secured to prevent it from becoming unstable and/or falling over.**

Devices installed in a rack or cabinet should be mounted as low as possible, with the heaviest devices at the bottom and progressively lighter devices installed above.

- **For safe operation do not install the switch with the back of the switch (with the fan vents) facing either downward or upward. Do not wall mount the PWR switches.**

Cautions

- Ensure the power source circuits are properly grounded, then use the power cord supplied with the switch to connect it to the power source.
- If your installation requires a different power cord than the one supplied with the switch, ensure the cord is adequately sized for the switch's current requirements. In addition, be sure to use a power cord displaying the mark of the safety agency that defines the regulations for power cords in your country. The mark is your assurance that the power cord can be used safely with the switch. If the PWR device's supplied power cord does not fit, contact HP.
- When installing the switch, the AC outlet should be near the switch and should be easily accessible in case the switch must be powered off.
- Ensure the switch does not overload the power circuits, wiring, and over-current protection. To determine the possibility of overloading the supply circuits, add together the ampere ratings of all devices installed on the same circuit as the switch and compare the total with the rating limit for the circuit. Maximum ampere ratings are usually printed on the devices near the AC power connectors.
- Do not install the switch in an environment where the operating ambient temperature might exceed 55°C (131°F), if using a 2600 switch, or 50°C (122°F) if using a 2600-PWR switch.
- Ensure the air flow around the sides and back of the switch is not restricted. Leave at least 7.6 cm (3 inches) for cooling. If this unit is placed in a fully-enclosed rack make certain the ambient temperature inside the rack near the switch does not exceed 55°C (if using a 2600 switch) or 50°C (if using a 2600-PWR switch).

1. Prepare the Installation Site

- **Cabling Infrastructure** - Ensure the cabling infrastructure meets the necessary network specifications. See the following table for cable types and lengths, and see appendix B, “[Switch Ports and Network Cables](#)” for more information:

Table 2-1. Summary of Cable Types to Use With the Switch

Port Type	Cable Type	Length Limits
Twisted-Pair Cables		
10/100/1000Base-T	<p>For either 10, 100 Mbps, or 1000 Mbps operation: Category 5 or better, 100-ohm UTP or shielded twisted-pair (STP) balanced cable. For 1000 Mbps (gigabit) operation, Category 5e cabling or better is recommended.</p>	<p>100 meters</p> <p>Note: The Switch 2600 Series devices are compatible with the IEEE 802.3ab standard including the “Auto MDI/MDI-X” feature, which allows use of either straight-through or crossover twisted-pair cables for connecting to any network devices including end nodes, such as computers, or to other switches, hubs, and routers.</p> <p>Note: For 1000 Mbps operation, all four wire pairs are used for data transmission, therefore PoE is not supported for 1000 Mbps operation.</p>

Port Type	Cable Type	Length Limits
Fiber Optic Cables		
Gigabit-SX (on Gigabit-SX-LC mini-GBIC)	Multimode fiber-optic cables fitted with LC connectors	220 meters to 550 meters depending on the cable used. See “Fiber-Optic Cables” on page B-2 for more information.
Gigabit-LX (on Gigabit-LX-LC mini-GBIC)	Single-mode fiber-optic cables fitted with LC connectors. The multimode cables specified for the Gigabit-SX mini-GBIC may also be used, but a mode-conditioning patch cord may be needed — see “ Mode Conditioning Patch Cord for Gigabit-LX ” on page B-3 for more information.	<ul style="list-style-type: none"> • single-mode cable = 10 kilometers • multimode cable = 550 meters
Gigabit-LH (on Gigabit-LH-LC mini-GBIC)	The same single-mode fiber-optic cables as for Gigabit-LX.	<ul style="list-style-type: none"> • 70 kilometers
Note:		
Gigabit-LH - Between the transmit and receive ends of the cable, at least 5db of attenuation is required for a reliable connection. This is equivalent to 20Km of the fiber-optic cable. For distances less than 20Km, you must add attenuators to bring the total attenuation to at least 5db. Most cable vendors carry attenuators.		

- **Installation Location** - Before installing the switch, plan its location and orientation relative to other devices and equipment:
 - In the front of the switch, leave at least 7.6 cm (3 inches) of space for the twisted-pair and fiber-optic cabling.
 - In the back of the switch, leave at least 3.8 cm (1 1/2 inches) of space for the power cord.
 - On the sides of the switch, leave at least 7.6 cm (3 inches) for cooling.

2. Installing or Removing mini-GBICs

You can install or remove a mini-GBIC from a mini-GBIC slot without having to power off the switch. Use only HP ProCurve mini-GBICs.

Notes

- The mini-GBIC slots are shared with the two 10/100/1000Base-T RJ-45 ports. If a mini-GBIC is installed in a slot, the associated RJ-45 port is disabled and cannot be used.
- The mini-GBIC ports operate only at full duplex. Half duplex operation is not supported.
- Ensure the network cable is NOT connected when you install or remove a mini-GBIC.

When this manual was printed, the supported mini-GBICs include the following:

- HP ProCurve Gigabit-SX-LC mini-GBIC (J4858A)
- HP ProCurve Gigabit-LX-LC mini-GBIC (J4859A)
- HP ProCurve Gigabit-LH-LC mini-GBIC (J4860A)

WARNING

The HP ProCurve mini-GBICs are Class 1 laser devices. Avoid direct eye exposure to the beam coming from the transmit port.

Installing the mini-GBICs:

Remove the protective plastic cover and retain it for later use. Hold the mini-GBIC by its sides and gently insert it into either of the slots on the switch until the mini-GBIC clicks into place.

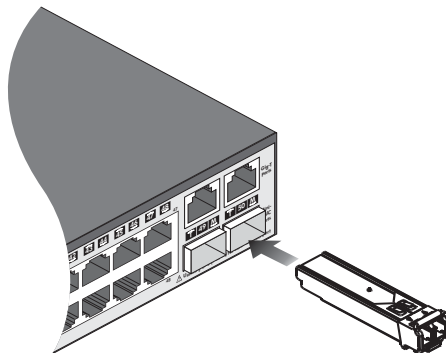

Removing the mini-GBICs:

Note

You should disconnect the network cable from the mini-GBIC before removing it from the switch.

Depending on when you purchased your HP ProCurve mini-GBIC, it may have either of three different release mechanisms: a plastic tab on the bottom of the mini-GBIC, a plastic collar around the mini-GBIC, or a wire bail.

To remove the mini-GBICs that have the plastic tab or plastic collar, push the tab or collar toward the switch until you see the mini-GBIC release from the switch (you can see it move outward slightly), and then pull it from the slot.

To remove the mini-GBICs that have the wire bail, lower the bail until it is approximately horizontal, and then using the bail, pull the mini-GBIC from the slot.

Replace the protective plastic cover on the mini-GBIC.

3. Verify the Switch Passes Self Test

Before mounting the switch in its network location, you should first verify it is working properly by plugging it into a power source and verifying it passes its self test.

1. Connect the power cord supplied with the switch to the power connector on the back of the switch, and then into a properly grounded electrical outlet.

HP 2626 and 2650 non-PWR switches



Connect power cord to the power connector

HP 2626 PWR and 2650 PWR switches



Connect power cord to the power connector

Note

The Switch 2600 Series devices do not have a power switch. They are powered on when the power cord is connected to the switch and to a power source. For safety, the power outlet should be located near the switch installation.

The switch automatically adjusts to any voltage between 100-240 volts and either 50 or 60 Hz. There are no voltage range settings required.

If your installation requires a different power cord than the one supplied with the switch, be sure the cord is adequately sized for the switch's current requirements. In addition, be sure to use a power cord displaying the mark of the safety agency that defines the regulations for power cords in your country. The mark is your assurance that the power cord can be used safely with the switch. If the PWR device's supplied power cord does not fit, contact HP.

2. Check the LEDs on the switch as described below.

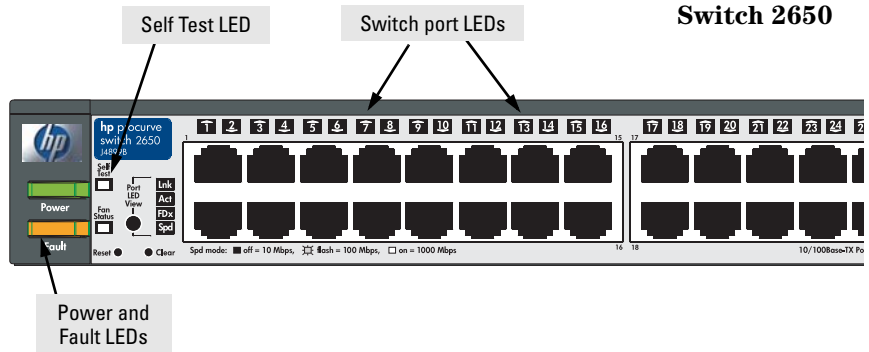

When the switch is powered on, it performs its diagnostic self test. Self test takes approximately 50 seconds to complete.

Switch 2650-PWR

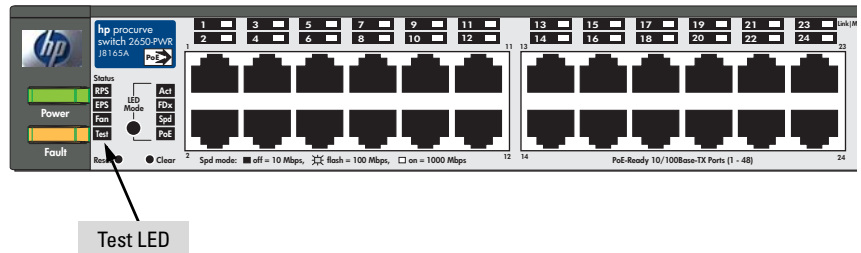

LED Behavior:

During the self test:

- Initially, all the switch and port LEDs are on. Most of the LEDs go off and then may come on again during phases of the self test.
- For the duration of the self test, the Self Test LED stays on.

When the self test completes successfully:

- The **Power** and **Fan Status** LEDs remain on.
- The **Fault** and **Self Test** LEDs go off.
- The port LEDs on the front of the switch go into their normal operational mode:
 - If the ports are connected to active network devices, the LEDs behave according to the Port LED View or LED Mode selected. For the non-PWR switches, in the default view mode (Link), the LEDs should be on. For the PWR switches, with two LEDs per connections, the Link LEDs will be on and the Mode LEDs will flicker if there is network activity.
 - If the ports are not connected to active network devices, the Link and Activity LEDs will stay off.

If the LED display is different than what is described above, especially if the **Fault** and **Self Test** LEDs stay on for more than 60 seconds or they start blinking, the self test has not completed correctly. Refer to chapter 4, “[Troubleshooting](#)” for diagnostic help.

4. Mount the Switch

After the switch passes self test, it is ready to be mounted in a stable location. The Switch 2600 Series can be mounted in these ways:

Mounting Location	Non-PWR Switches	PWR Switches
In a rack or cabinet	Yes	Yes
On a horizontal surface	Yes	Yes
On a wall	Yes	No

Rack or Cabinet Mounting

The Switch 2600 Series devices are designed to be mounted in any EIA-standard 19-inch telco rack or communication equipment cabinet. Note that the mounting brackets have multiple mounting holes and can be rotated allowing for a wide variety of mounting options. *Secure the rack in accordance with the manufacture’s safety guidelines.*

WARNING

For safe operation, please read the mounting precautions on [page 2-4](#), before mounting a switch.

**Equipment
Cabinet
Note**

The 12-24 screws supplied with the switch are the correct threading for standard EIA/TIA open 19-inch racks. If installing the switch in an equipment cabinet such as a server cabinet, use the clips and screws that came with the cabinet in place of the 12-24 screws that are supplied with the switch.

Rack Mounting the 2626-PWR and 2650-PWR switches

1. Use a #1 Phillips (cross-head) screwdriver and attach the mounting brackets to the switch with the included 8-mm M4 screws.

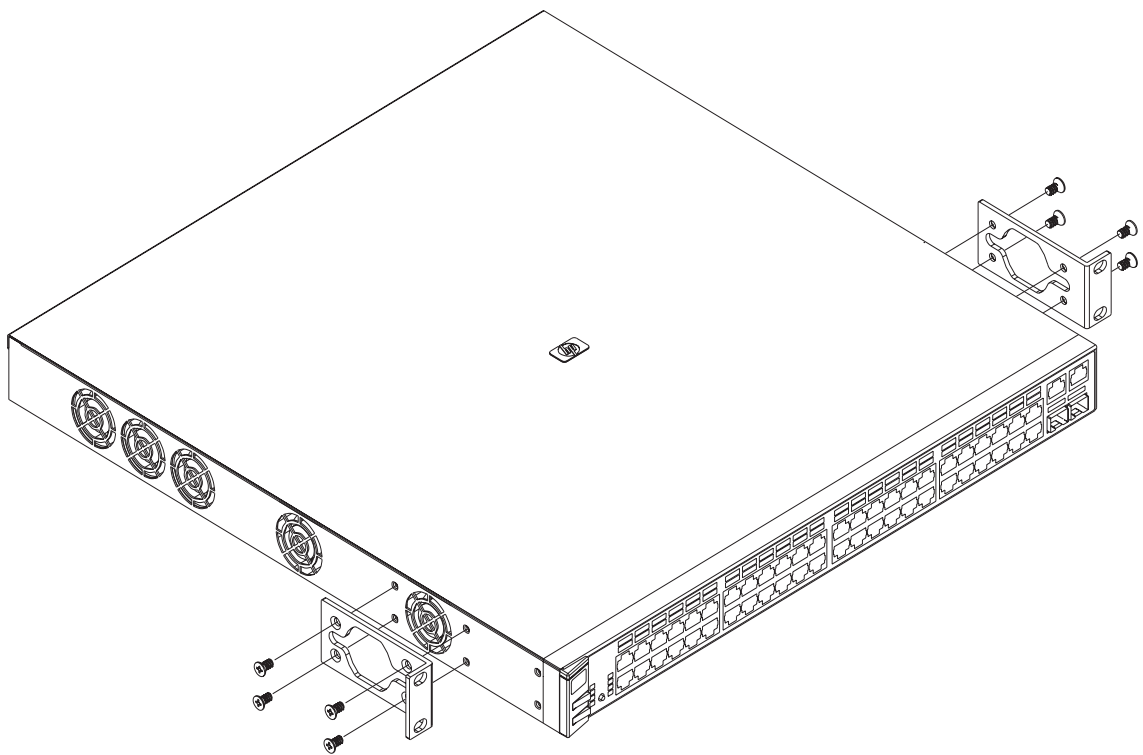

WARNING

For safe reliable installation, only use the screws provided in the accessory kit to attach the mounting brackets to the switch.

Note

The mounting brackets have multiple mounting holes and can be rotated allowing for a wide variety of mounting options. These include mounting the switch so that its front face is flush with the face of the rack, or mounting it in a more balanced position as shown in the illustration above.

2. Hold the switch with attached brackets up to the rack and move it vertically until rack holes line up with the bracket holes, then insert and tighten the four number 12-24 screws holding the brackets to the rack.

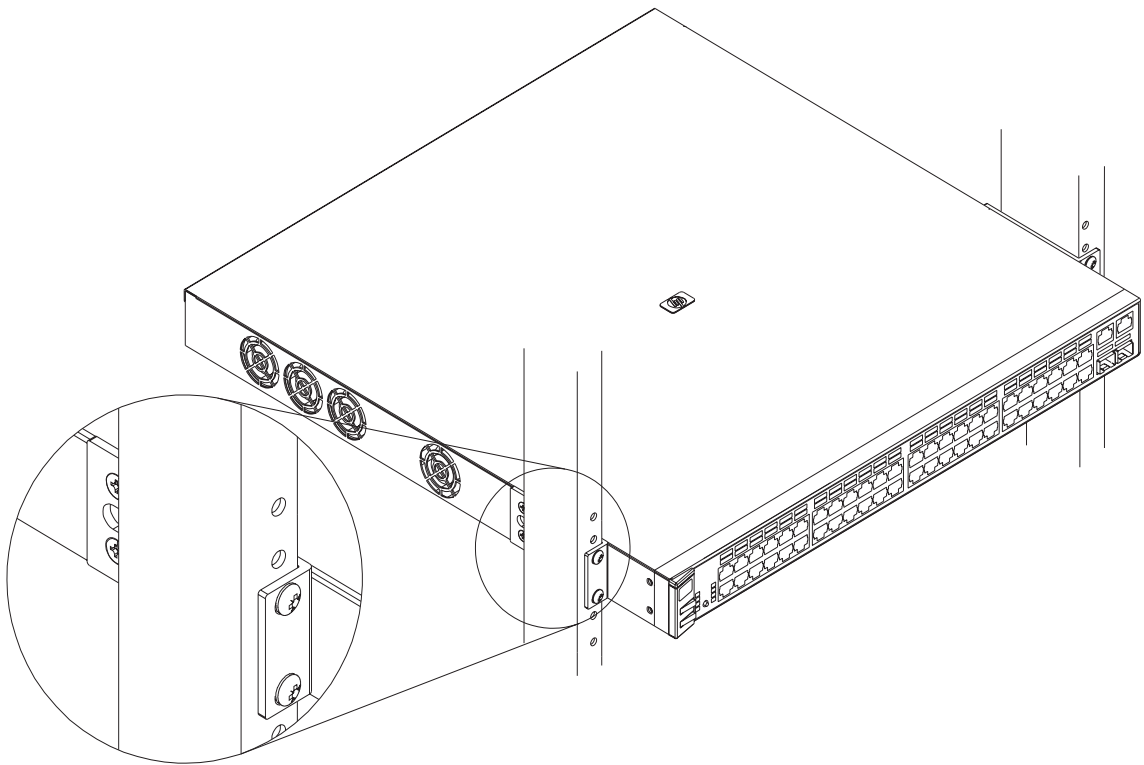

Rack Mounting the Non-PWR Switches

1. Use a #1 Phillips (cross-head) screwdriver and attach the mounting brackets to the switch with the included 8-mm M4 screws.

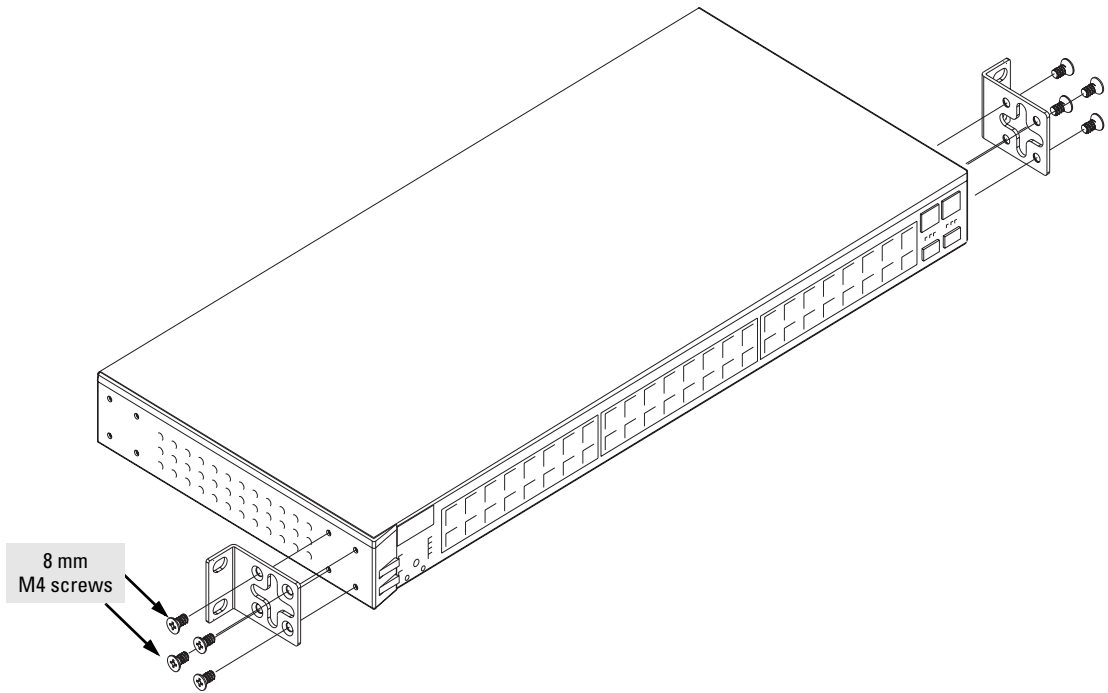

Note

The mounting brackets have multiple mounting holes and can be rotated allowing for a wide variety of mounting options. These include mounting the switch so that its front face is flush with the face of the rack, or mounting it in a more balanced position as shown in the illustration.

WARNING

For safe reliable installation, only use the screws provided in the accessory kit to attach the mounting brackets to the switch.

2. Hold the switch with attached brackets up to the rack and move it vertically until rack holes line up with the bracket holes, then insert and tighten the four number 12-24 screws holding the brackets to the rack.

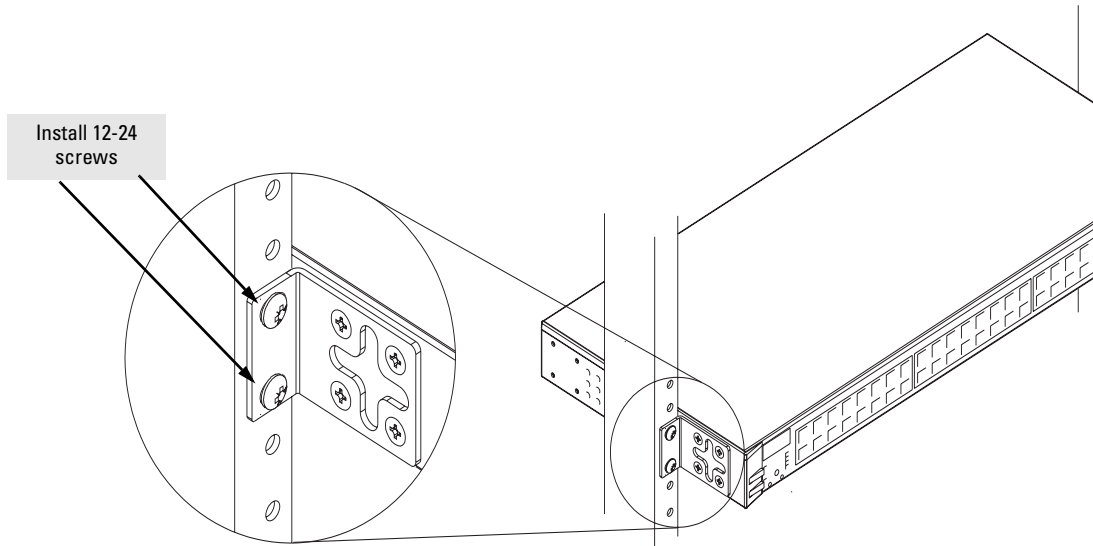

Flat Wall Mounting

You can mount the Non-PWR switches on a wall as shown in the illustration on the next page. However, this is not supported for the PWR switches. Wall mounting the PWR switches is not supported because of the size and weight of the devices.

WARNING

For safe operation do not install the switch with the back face of the switch (with the fan vents) facing either downward or upward. Do not wall mount a PWR switch.

Caution

The switch should be mounted only to a wall or wood surface that is at least 1/2-inch plywood or its equivalent.

Installing the Switch

Installation Procedures

1. Use a #1 Phillips (cross-head) screwdriver and attach the mounting brackets to opposite corners of the switch with the included 8-mm M4 screws.
2. Attach the switch to the wall or wood surface with two 5/8-inch number 12 wood screws (not included).

For "Flat" Wall Mounting

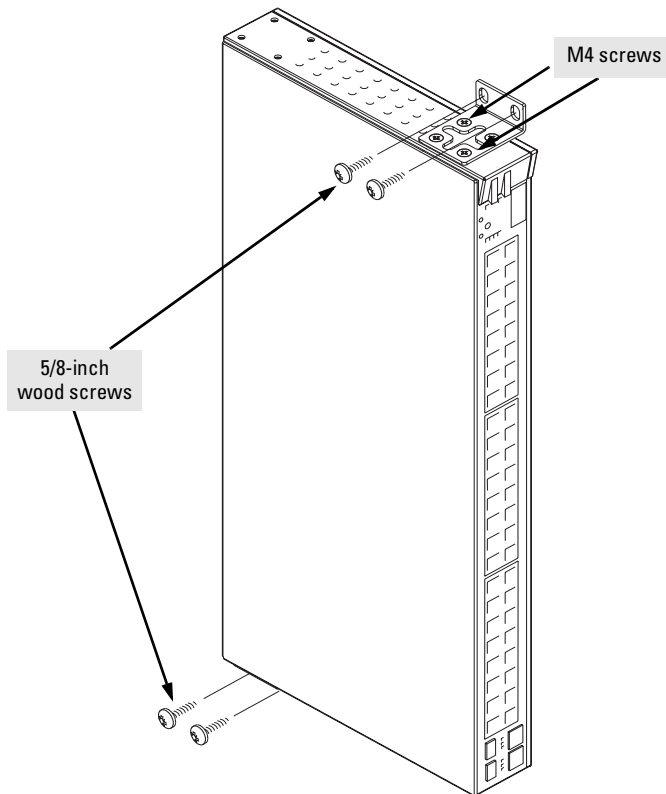

The brackets are attached on opposite corners to improve the stability of the switch on the wall.

Note

The Switch 2600-PWR Series devices are not wall mountable.

Horizontal Surface Mounting

Place the switch on a table or other horizontal surface. The switch comes with rubber feet in the accessory kit that can be used to help keep the switch from sliding on the surface.

Attach the rubber feet to the four corners on the bottom of the switch within the embossed angled lines. Use a sturdy surface in an uncluttered area. You may want to secure the networking cables and switch power cord to the table leg or other part of the surface structure to help prevent tripping over the cords.

Caution

Ensure the air flow is not restricted around the sides and back of the switch.

5. Connect the Switch to a Power Source

1. Plug the included power cord into the switch's power connector and into a nearby AC power source.
2. Re-check the LEDs during self test. See "LED Behavior" on [page 2-10](#).

6. Connect the Network Cables

Connect the network cables, described under “Cabling Infrastructure” ([page 2-5](#)), from the network devices or your patch panels to the fixed RJ-45 ports on the switch or to any mini-GBICs you have installed in the switch.

Using the RJ-45 Connectors

To connect:

Push the RJ-45 plug into the RJ-45 port until the tab on the plug clicks into place. When power is on for the switch and for the connected device, the Link LED for the port should light to confirm a powered-on device (for example, an end node) is at the other end of the cable.

If the Link LED does *not* go on when the network cable is connected to the port, see “Diagnosing With the LEDs” in chapter 4, “Troubleshooting”.

To disconnect:

Press the small tab on the plug and pull the plug out of the port.

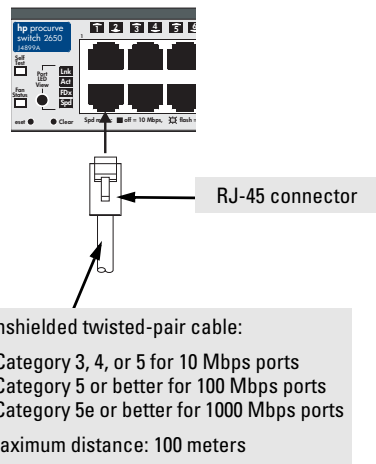

Connecting Cables to mini-GBICs

Note

The mini-GBIC slots are shared with the two 10/100/1000Base-T RJ-45 ports. If a mini-GBIC is installed in a slot, the associated RJ-45 port is disabled.

If you have any mini-GBICs installed in the switch, the type of network connections you will need to use depends on the type of mini-GBICs you have installed. See the table on [page 2-5](#), and appendix B, “[Switch Ports and Network Cables](#)”, for the mini-GBIC cabling information.

For mini-GBICs ports, and in general for all the switch ports, when a network cable from an active network device is connected to the port, the port LED for that port should go on. If the port LED does *not* go on when the network cable is connected to the port, see “[Diagnosing with the LEDs](#)” in chapter 4, “Troubleshooting”.

7. (Optional) Connect a Redundant Power Supply to a Switch 2600-PWR Series

The HP ProCurve 600 Redundant and External Power Supply, (J8168A), hereafter referred to as the HP 600 RPS/EPS, is an accessory product for the Switch 2600-PWR Series and specific other HP ProCurve switches. The HP 600 RPS/EPS provides two types of power to the switches:

- Redundant power to one of up to six switches, to back up the internal switch power supply in case of AC power loss, or a fault condition. Should the internal switch power supply fail, power will be supplied from the HP 600 RPS/EPS, if it is available, that is, if the HP 600 RPS/EPS is not already providing power to a higher priority switch. See the documentation that came with your HP 600 RPS/EPS for more information.
- External Power-over-Ethernet (PoE) power to up to two switch products. The HP 600 RPS/EPS can supply 408 watts of PoE power to the switch if the internal PoE power supply should fail. For the Switch 2650-PWR the external PoE power is additional power made available to the switch's ports. For further information regarding the HP 600 RPS/EPS PoE capabilities, see the *PoE Planning and Implementation Guide*, which is on the Documentation CD-ROM that came with your switch.

The HP 600 RPS/EPS is an unmanaged power supply that only provides information by way of LEDs.

RPS/EPS Operation

The RPS/EPS monitors the power signal from the switch by detecting that the RPS/EPS is connected to a switch with an RPS/EPS cable. When the power from the switch is no longer detected, the RPS/EPS will turn on and provide power to the switch within 1ms.

The RPS/EPS supports hot plugging of the RPS/EPS cable without causing a reboot of the switch or causing the power supply in either the RPS/EPS or switch to shut down temporarily or permanently. For more information refer to the documentation that came with the RPS/EPS.

Operating Characteristics of the HP 600 RPS/EPS (J8168A)

The HP 600 RPS/EPS has six RPS ports, each of which can provide redundant +12V power to a connected switch, but only one connector can provide this power at a given time. If a switch with no AC power is connected to an operating HP 600 RPS/EPS, it will receive power if power is available (no higher priority port is already using the RPS power).

If two or more devices fail, priority goes to the device plugged into the lower numbered port on the HP 600 RPS/EPS unit. Consequently the most important switch should be plugged into port one on the HP 600 RPSEPS. In this state, the “Connected” LED should be ON, and the “Power Status” LED should be BLINKING on the lower priority RPS port not supplying power. (Refer to the documentation that came with your HP 600 RPS/EPS unit.)

The HP 600 RPS/EPS also has two EPS Ports. The HP 600 RPS/EPS can provide a maximum of 408 watts of PoE power to a switch. It is important to understand the PoE power requirements of the 2626-PWR and 2650-PWR switches because if the PoE power is not planned and implemented correctly the end devices connected to the switch ports may not receive power if an internal switch PoE power supply should fail. For further information regarding the HP 600 RPS/EPS PoE capabilities, see the *PoE Planning and Implementation Guide*, which is on the Documentation CD-ROM that came with your switch.

For redundant AC power, connect the HP RPS/EPS to the switch using one of the six supplied RPS cables. RPS cables are 1.25 meters (4.10 feet) in length.

For redundant or additional PoE power, connect the HP 600 RPS/EPS to the switch using one of the two supplied EPS cables. EPS cables are 2.00 meters (6.56 feet) in length.

HP 600 RPS/EPS LEDs

The RPS/EPS LEDs are located on the back of the RPS/EPS. These LEDs are duplicated on the front of the device for your convenience. The following graphic shows an example of the back of the EPS/RPS. There are two green LEDs for each RPS/EPS port:

- Device Connected
- Power Status

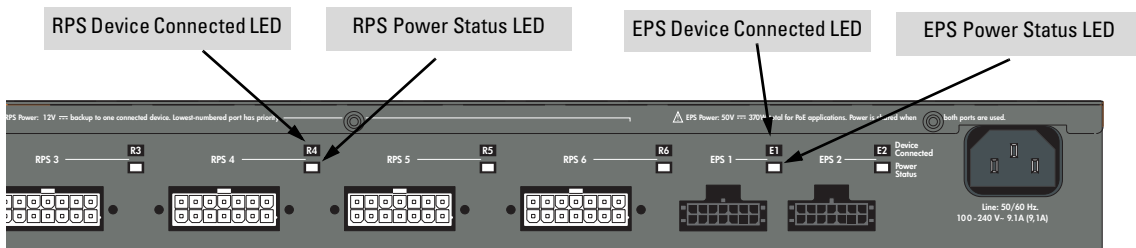

The following states provide status of an RPS/EPS port.

Fault (located on the front)	Device Connected	Power Status	Message
Off	Off	Off	Nothing Connected
On or Off	Off	On	Not a valid state - should never happen
Off	On	Off	Switch is connected, RPS is available but not required
Off	On	On	RPS is powering the connected device
Blinking	Off	Blinking	RPS port is in fault condition
Off	On	Blinking	Switch is requesting power, RPS can not provide it

Installing the Switch

HP 600 RPS/EPS Connectivity

The following illustration shows an example of connectivity between an RPS/
EPS device and a switch device as a redundant AC power supply.

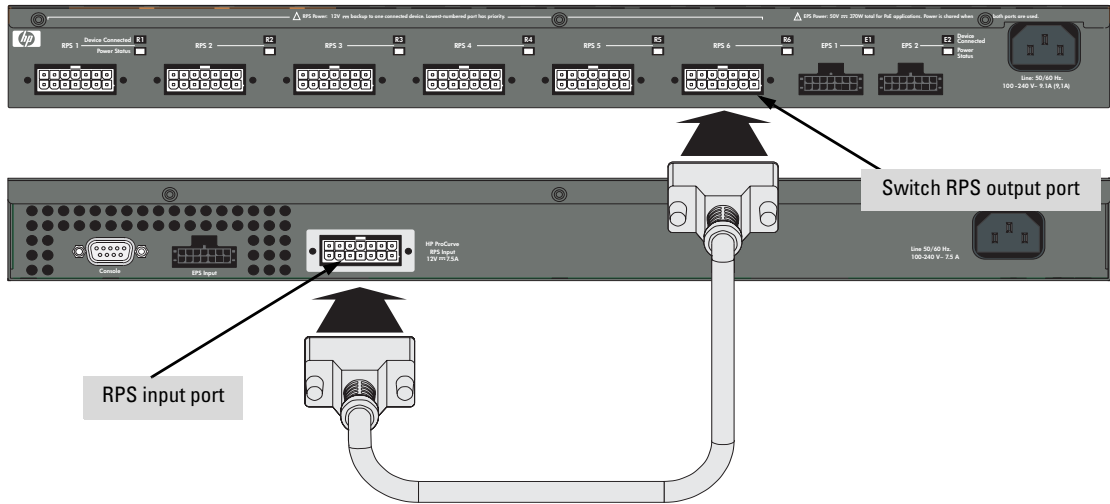

The following illustration shows an example of connectivity between an RPS/
EPS device and six switch devices as a redundant AC power supply.

HP 2650-PWR switches

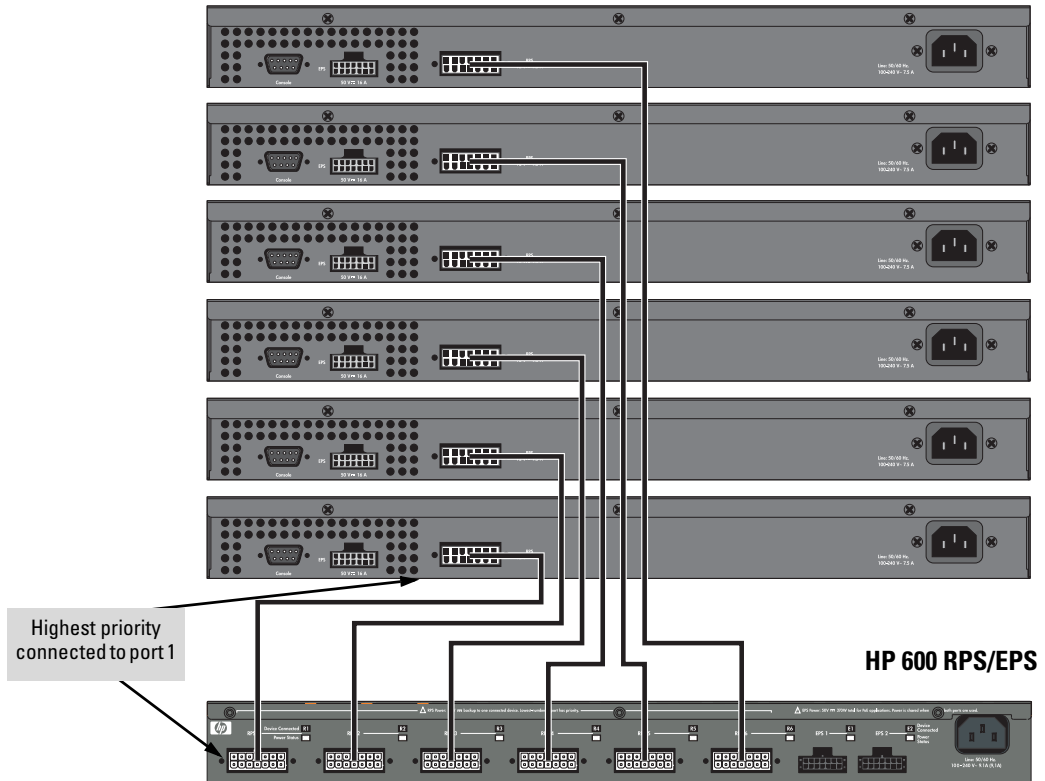

The HP 600 RPS/EPS can provide backup power for up to six switches. The HP 600 RPS/EPS can supply power to only one connected and failed switch at a time. In the illustration above, the switch connected to RPS port 1 has the highest priority and the switch connected to RPS port 6 has the lowest priority. When multiple switches fail, a switch connected to a higher priority port always receives power before a switch connected to a lower priority port.

Installing the Switch

Installing the Switch

Installation Procedures

The following illustration demonstrates an example of connectivity between an RPS/EPS device and a Switch device as a PoE power supply.

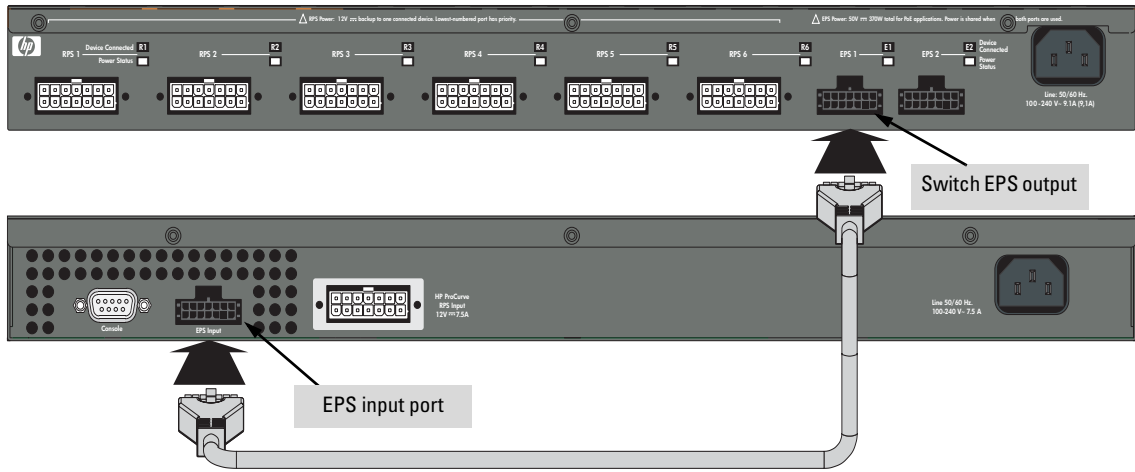

HP 610 EPS LEDs

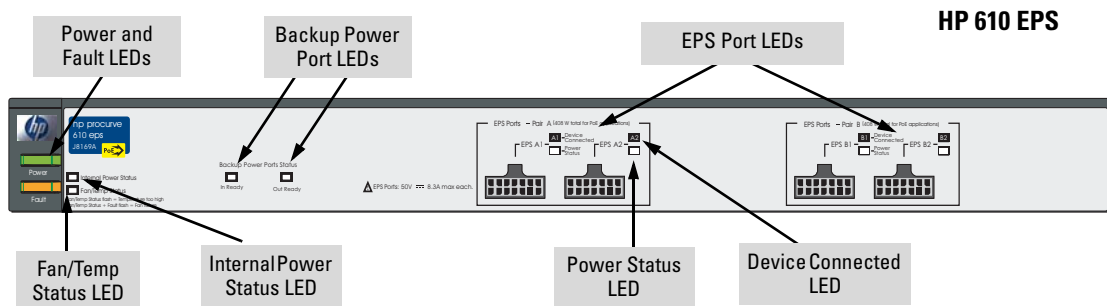

For a complete description of the LEDs see the documentation that came with the HP 610 EPS.

Operating Characteristics of the HP 610 EPS (J8169A)

The HP 610 EPS does not have any RPS ports and can not supply RPS power. It has four EPS Ports. Two in Pair A and two in Pair B. Each pair can provide a maximum of 408 watts of PoE power to a switch. Again, it is important to understand the PoE power requirements of the switches. For further information regarding the HP 610 EPS PoE capabilities, see the *PoE Planning and Implementation Guide*, which is on the Documentation CD-ROM that came with your switch and the documentation that came with the HP 610 EPS.

For redundant or additional PoE power, connect the HP 610 EPS to the switch using one of the four supplied EPS cables. EPS cables are 2.00 meters (6.56 feet) in length.

The following illustration demonstrates an example of connectivity between an HP 610 EPS device and two Switch devices as a PoE power supply.

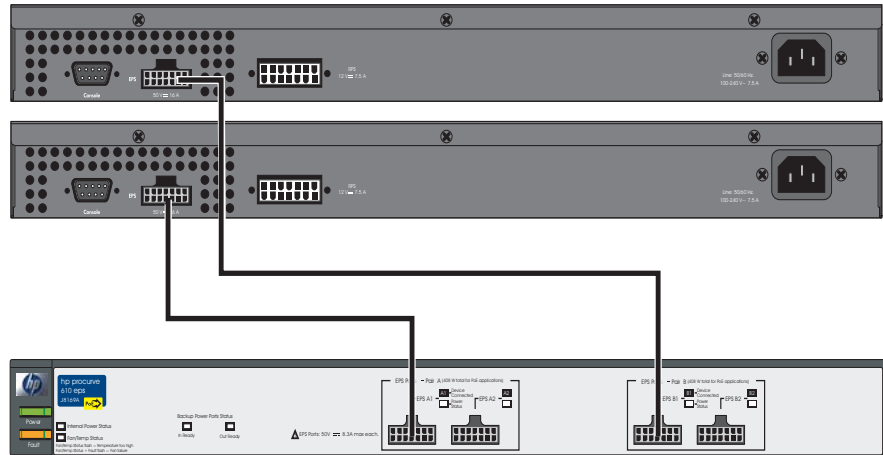

In this example each switch receives 408 watts of PoE power. Each switch is connected to one port of each pair. If the two switches were connected to both ports of a pair, both ports of pair A for example, then each switch receives 204 watts. See the following example.

The following illustration demonstrates an example of connectivity between an HP 610 EPS device and four Switch devices as a PoE power supply. In this example each switch receives 204 watts of PoE power.

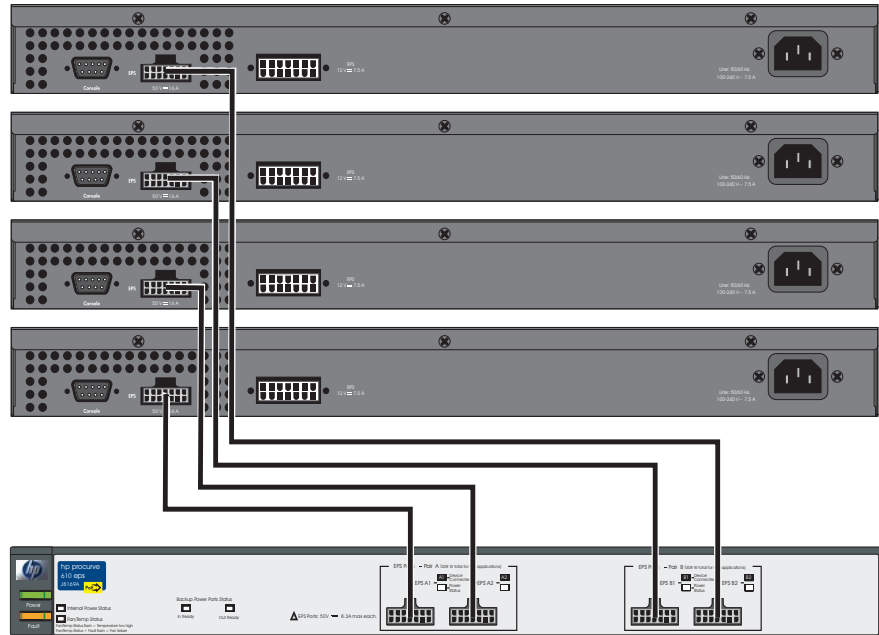

Installing the Switch

8. (Optional) Connect a Console to the Switch

The Switch 2600 Series has a full-featured, easy to use console interface for performing switch management tasks including the following:

- monitor switch and port status and observe network activity statistics
- modify the switch's configuration to optimize switch performance, enhance network traffic control, and improve network security
- read the event log and access diagnostic tools to help in troubleshooting
- download new software to the switch
- add passwords to control access to the switch from the console, web browser interface, and network management stations

The console can be accessed through these methods:

- **Out-of-band:** The Switch 2600 Series come with a serial cable for connecting a PC or VT-100 terminal, to be used as a console, directly to the switch.
- **In-Band:** Access the console using Telnet from a PC or UNIX station on the network, and a VT-100 terminal emulator. This method requires that you first configure the switch with an IP address and subnet mask by using either out-of-band console access or through DHCP/Bootp. For more information on IP addressing and on starting a Telnet session, see chapter 3, “[Configuring the Switch](#)”, in the *Management and Configuration Guide*, which is on the Documentation CD-ROM that came with your switch.

The Switch 2600 Series can simultaneously support one out-of-band console session through the Console Port and in-band Telnet console sessions.

Terminal Configuration

To connect a console to the switch, configure the PC terminal emulator as a DEC VT-100 (ANSI) terminal or use a VT-100 terminal, and configure either one to operate with these settings:

- any baud rate from 1200 to 115200 (the switch senses the speed)
- 8 data bits, 1 stop bit, no parity, and flow control set to Xon/Xoff
- For the Windows Terminal program, also disable (uncheck) the “Use Function, Arrow, and Ctrl Keys for Windows” option
- For the Hilgraeve HyperTerminal program, select the “Terminal keys” option for the “Function, arrow, and ctrl keys act as” parameter

If you want to operate the console using a different configuration, make sure you change the settings on both the terminal and on the switch so they are compatible. Change the switch settings first, then change the terminal settings, then reboot the switch and reestablish the console session.

Direct Console Access

To connect a console to the switch, follow these steps:

1. Connect the PC or terminal to the switch's Console Port using the console cable included with the switch. (If your PC or terminal has a 25-pin serial connector, first attach a 9-pin to 25-pin straight-through adapter at one end of the console cable.)
2. Turn on the terminal or PC's power and, if using a PC, start the PC terminal program.
3. Press **[Enter]** two or three times and you will see the copyright page and the message "Press any key to continue". Press a key, and you will then see the switch console command (CLI) prompt, for example:

HP ProCurve Switch 2650#

If you want to continue with console management of the switch at this time, see chapter 3, "Getting Started With Switch Configuration" for some basic configuration steps. For more detailed information, refer to the *Management and Configuration Guide*, which is on the Documentation CD-ROM that came with your switch.

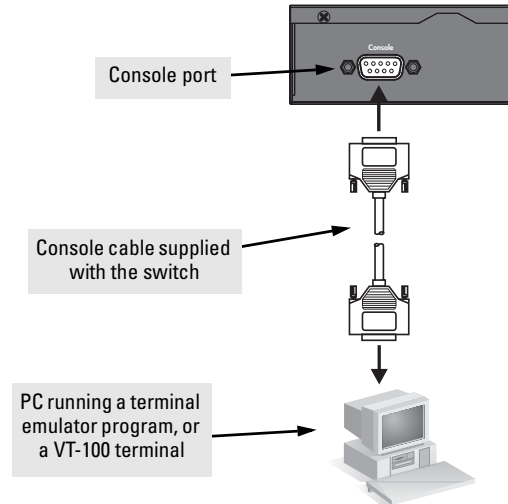

Sample Network Topologies for Non-PWR Switches

This section shows a few sample network topologies in which the Switch 2650 is implemented. For more topology information, see the HP network products World Wide Web site, <http://www.hp.com/go/hpprocurve>.

As a Desktop Switch

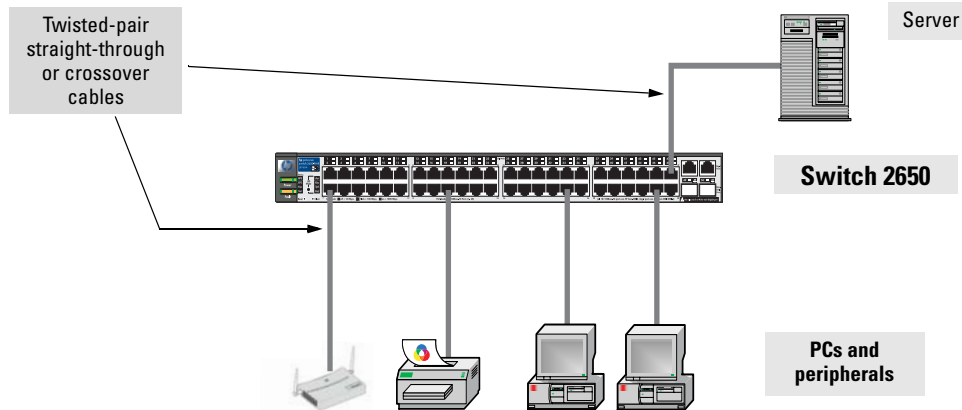

The Switch 2600 Series devices are designed to be used primarily as desktop switches to which end nodes, printers and other peripherals, and servers are directly connected, as shown in the above illustration. The end node devices are connected to the switch by straight-through or crossover twisted-pair cables. Either cable type can be used because of the “HP Auto-MDIX” and “IEEE Auto MDI/MDI-X” features on the Series 2600 Switches.

As a Segment Switch

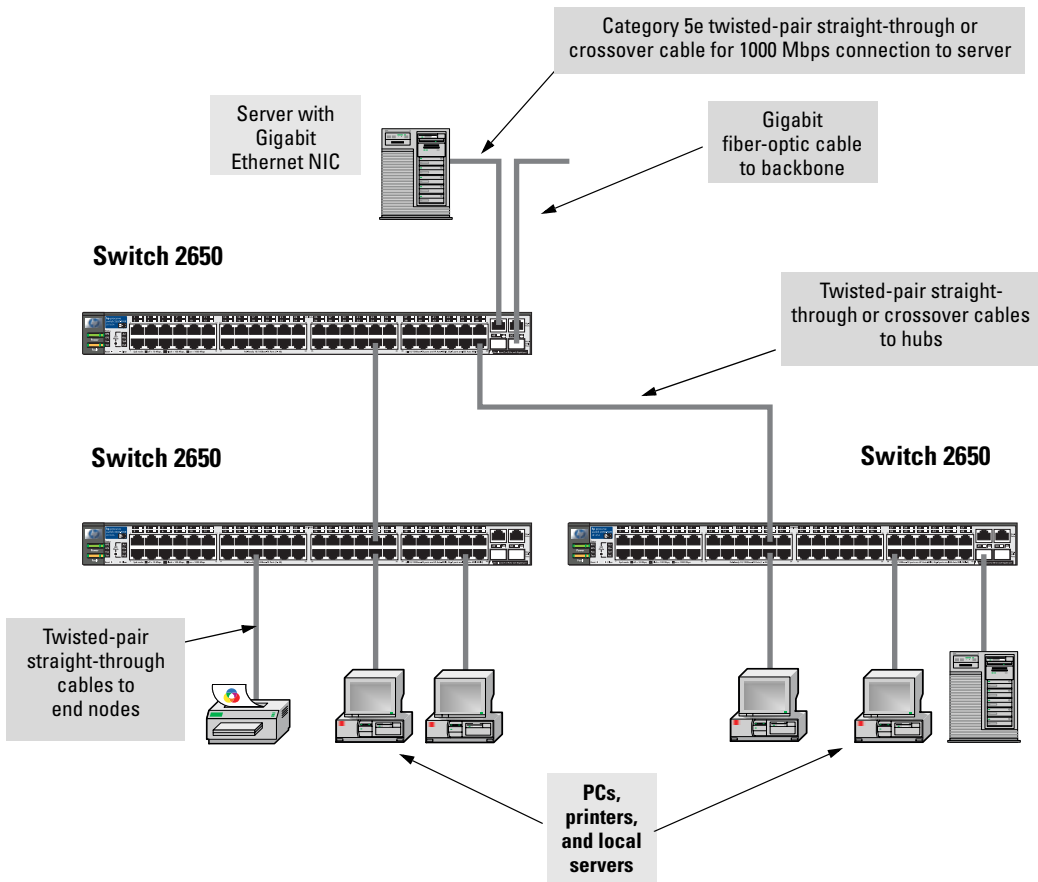

The Switch 2600 Series devices also work well as a segment switches. That is, with their high performance, they can be used for interconnecting network segments—simply connect the network devices that form those segments to the Switch 2600 Series devices.

In the illustration above, two “Fast Ethernet” switches with PCs, printers, and local servers attached, are both connected to a Switch 2650. The devices attached to the two desktop switches can now communicate with each other through the switch. They can also all communicate with the server that is connected to a 1000Base-T port on the switch.

Installing the Switch

Sample Network Topologies for Non-PWR Switches

Because the Series 2600 Switches have the “HP Auto-MDIX” and “IEEE Auto MDI/MDI-X” features, the connections between the switch and the hubs, and between the switch and end nodes or servers can be through category 5 straight-through or crossover twisted-pair cable. Category 3 or 4 cable can also be used if the connection is 10 Mbps only. In all cases, the device ports must be configured to auto negotiate the link characteristics for this feature to work.

The switch, in turn, can be connected to a network backbone through fiber-optic cabling connected to a Gigabit-SX, -LX, or -LH mini-GBIC. Now, all the devices on these network segments can access other network resources that are connected elsewhere on the network backbone.

Connecting to a Backbone Switch

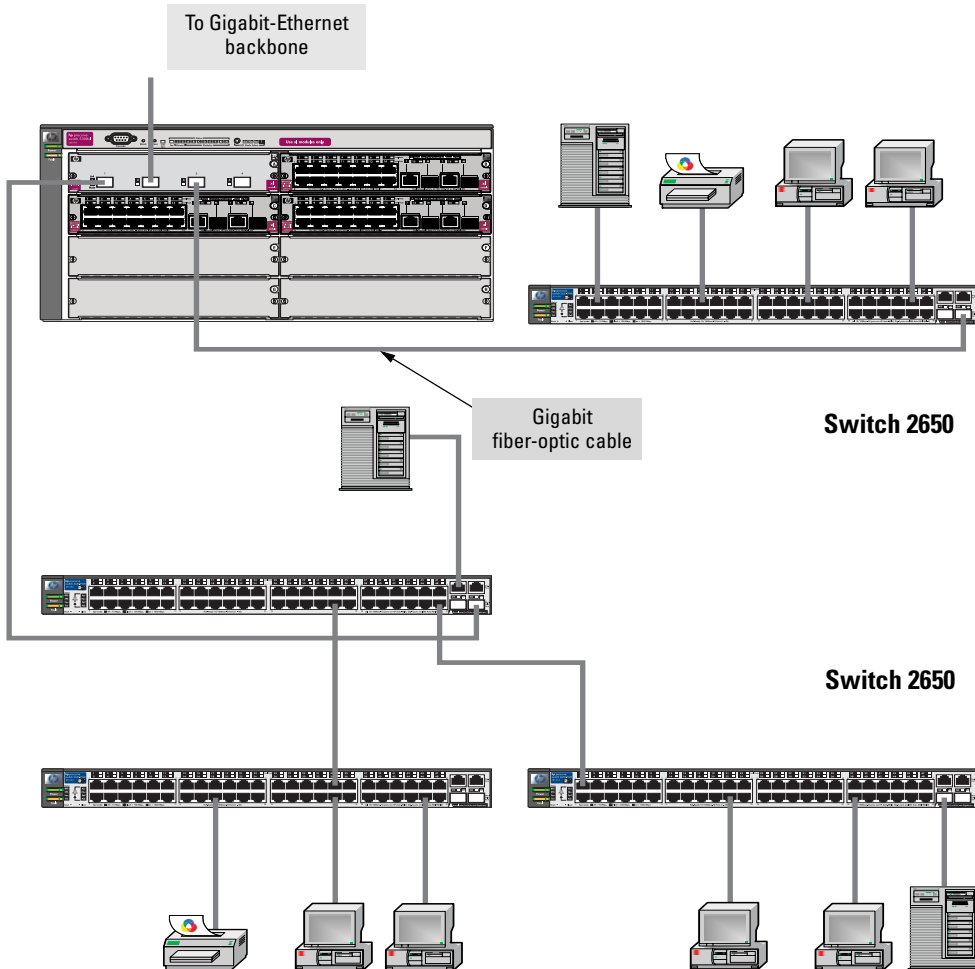

The simpler desktop and segment networks shown in the previous two examples can easily be combined and expanded. For example, you could use an HP ProCurve Switch 5308 to interconnect each of your smaller switched workgroups to form a larger switched network. All the devices in this network can communicate with each other. For example, with Gigabit-SX Mini-GBICs installed in a Mini-GBIC Module, in the Switch 5308, the entire switched topology could be connected to a campus backbone, as shown in the illustration above.

Note

In the illustration above, the 1000 Mbps fiber-optic connection between the Switch 2650 and the Switch 5308 is by way of a Gigabit-SX mini-GBIC installed in the Switch 2650 connected to a mini-GBIC Module in the Switch 5308.

Sample Network Topologies for PWR Switches

This section shows a few sample network topologies in which the Switch 2650-PWR is implemented. For more topology information, see the HP network products Web site, <http://www.hp.com/go/hpprocurve>.

As a Desktop Switch Implementing PoE

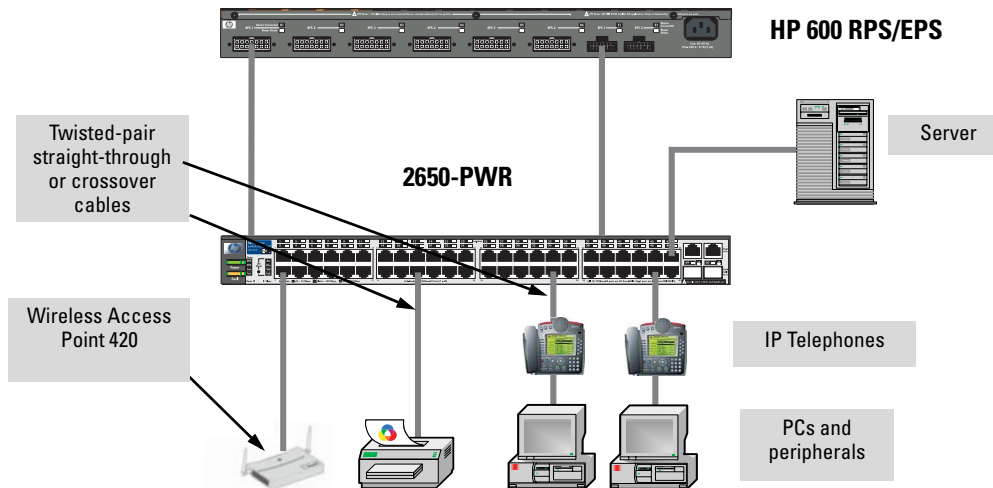

The Switch 2600-PWR Series devices are also designed to be used as desktop switches to which end nodes, printers and other peripherals, and servers are directly connected, as shown in the above illustration. Except now these switches can supply PoE power to end devices such as IP telephones and wireless access points (WAP).

As shown in the above illustration the IP telephones can be connected in line, that is, between the switch and the end device, in this case a PC. The IP telephones have two ports, one in and one out. Therefore the phone receives voice and power from the switch and the PC can send and receive data through the phone to the switch.

The end node devices are connected to the switch by straight-through or crossover twisted-pair cables. Either cable type can be used because of the “HP Auto-MDIX” and “IEEE Auto MDI/MDI-X” features on the Series 2600-PWR Switches.

As a Segment Switch Implementing PoE

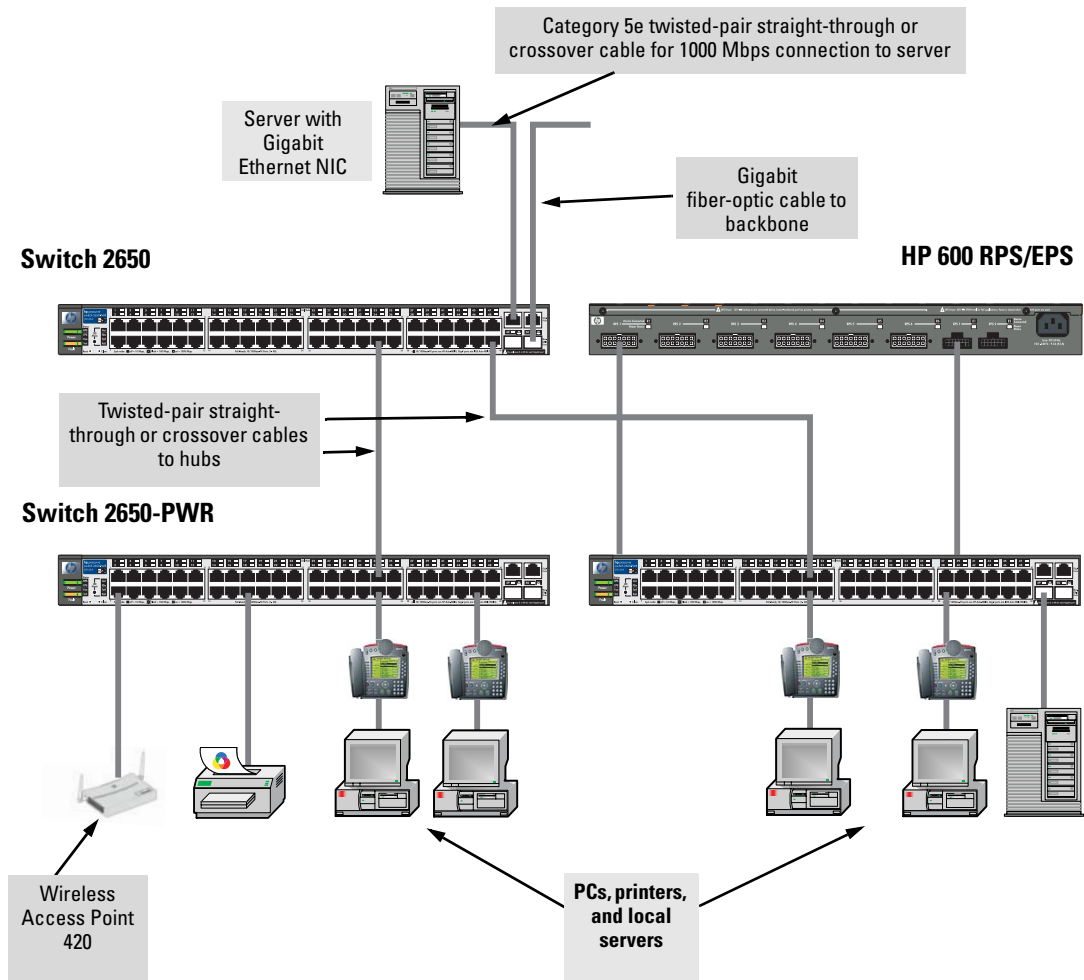

Installing the Switch

As shown in the illustration above, the IP telephones have been inserted in between the Switch 2650-PWR and the PCs, and a WAP has been connected to the Switch 2650-PWR. Both the telephones and WAP will receive PoE power from the Switch 2650-PWR. Only devices directly connected to the PWR switches can receive PoE power if they are 802.3af compliant. Devices connected to a non-PWR segment switch cannot receive PoE power.

Connecting to a Backbone Switch Implementing PoE

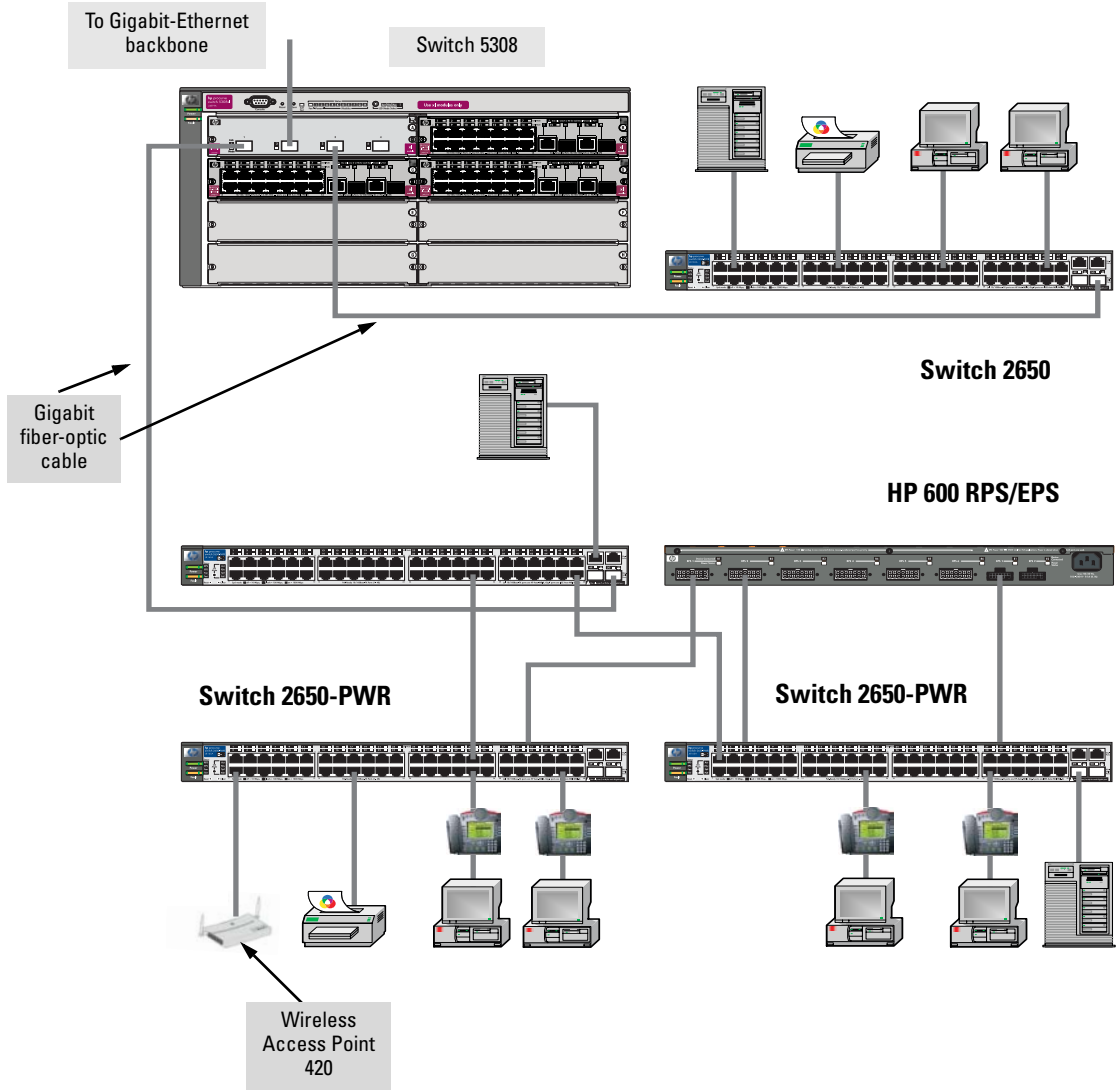

Stacking the Switch

Switch 2600 and 2600-PWR Series devices can be connected together, through standard network connections, and managed through a single IP address. Up to 16 switches can be connected together in such a “virtual stack”.

You identify a Switch 2600 or 2600-PWR Series device as the “Commander” and give that switch an IP address. Up to 15 other switches in the network can then easily be configured as Members of the stack and managed through the Commander’s IP address. The management includes Telnet access and web browser interface access to the Commander and to each Member switch through the Commander.

For more information on stacking your switch, see the *Management and Configuration Guide*, which is on the Documentation CD-ROM that came with your switch.

— *This page is intentionally unused.* —

Configuring the Switch

This chapter is a guide for using the console Switch Setup screen to quickly assign an IP (Internet Protocol) address and subnet mask to the switch, set a Manager password, and, optionally, configure other basic features.

For more information on using the switch console and the web browser interface, please see the *Management and Configuration Guide*, which is on the Documentation CD-ROM that came with your switch.

Recommended Minimal Configuration

In the factory default configuration, the switch has no IP (Internet Protocol) address and subnet mask, and no passwords. In this state, it can be managed only through a direct console connection. To manage the switch through in-band (networked) access, you should configure the switch with an IP address and subnet mask compatible with your network. Also, you should configure a Manager password to control access privileges from the console and web browser interface. Other parameters in the Switch Setup screen can be left at their default settings or you can configure them with values you enter.

Many other features can be configured through the switch's console interface, to optimize the switch's performance, to enhance your control of the network traffic, and to improve network security. Once an IP address has been configured on the switch, these features can be accessed more conveniently through a remote Telnet session, through the switch's web browser interface, and from an SNMP network management station running a network management program. For a listing of switch features available with and without an IP address, refer to "How IP Addressing Affects Switch Operation" in the *Management and Configuration Guide*, which is on the Documentation CD-ROM that came with your switch.

For more information on IP addressing, refer to "IP Configuration" in the *Management and Configuration Guide*.

Note

By default, the switch is configured to acquire an IP address configuration from a DHCP or Bootp server. To use DHCP/Bootp instead of the manual method described in this chapter, see “DHCP/Bootp Operation” in the *Management and Configuration Guide*, which is on the Documentation CD-ROM that came with your switch.

Using the Console Setup Screen

The quickest and easiest way to minimally configure the switch for management and password protection in your network is to use a direct console connection to the switch, start a console session, and access the Switch Setup screen.

1. Using the method described in the preceding section, connect a terminal device to the switch and display the switch console command line interface (CLI) prompt (the default display).

The CLI prompt appears displaying the switch model number:

```
HP ProCurve Switch 2650#
```

2. At the prompt, enter the **setup** command to display the Switch Setup screen. The following illustration shows the Setup screen with the default settings.

```

HP ProCurve Switch 2650                               1-Jan-2003   2:59:24
=====  CONSOLE - MANAGER MODE  =====
                          Switch Setup

System Name : HP ProCurve Switch 2650
System Contact :
Manager Password :                               Confirm Password :
Logon Default : CLI                               Time Zone [0] : 0
Community Name : public                           Spanning Tree Enabled [No] : No

Default Gateway :
Time Sync Method [None] : TIMEP
TimeP Mode [Disabled] : Disabled

IP Config [DHCP/Bootp] : DHCP/Bootp
IP Address :
Subnet Mask :

Actions->   Cancel   Edit   Save   Help

Enter System Name - up to 25 characters.
Use arrow keys to change field selection, <Space> to toggle field choices,
and <Enter> to go to Actions.
    
```

3. Use the **[Tab]** key to select the **Manager Password** field and enter a manager password of up to 16 printable ASCII characters.

4. [Tab] to the **IP Config (DHCP/Bootp)** field and use the Space bar to select the **Manual** option.
5. [Tab] to the **IP Address** field and enter the IP address that is compatible with your network.
6. [Tab] to the **Subnet Mask** field and enter the subnet mask used for your network.
7. Press [Enter], then [S] (for **Save**).

Here is some information on the fields in the Setup screen. For more information on these fields, see the *Management and Configuration Guide*, which is on the Documentation CD-ROM that came with your switch:

Parameter	Default	
System Name	blank	Optional; up to 25 characters, including spaces
System Contact	blank	Optional; up to 48 characters, including spaces
Manager Password	blank	Recommended; up to 16 characters (no blank spaces)
Logon Default	CLI	The default setting selects the command line interface for console access. The alternative is the menu interface.
Time Zone	0 (none)	Optional; 1440 to -1440. The number of minutes your location is to the West (-) or East (+) of GMT.
Community Name	public	Default setting recommended.
Spanning Tree Enabled	No	Default setting recommended unless STP is already running on your network or the switch will be used in complex network topologies.
Default Gateway	blank	Optional; Enter the IP address of the next-hop gateway node if network traffic needs to be able to reach off-subnet destinations.
Time Sync Method	None	Optional; The protocol the switch uses to acquire a time signal. The options are SNTP and TimeP.
TimeP Mode	Disabled	Optional; The method the switch uses to acquire the TimeP server address.
IP Config (DHCP/Bootp)	DHCP/Bootp	Set to Manual unless a DHCP/Bootp server is used on your network to configure IP addressing.
IP Address	xxx.xxx.xxx.xxx	Recommended; If you set IP Config to Manual, then enter an IP address compatible with your network.
<p>Note: The IP address and subnet mask assigned for the switch must be compatible with the IP addressing used in your network. For more information on IP addressing, see the <i>Management and Configuration Guide</i>, which is on the Documentation CD-ROM that came with your switch.</p>		
Subnet Mask	xxx.xxx.xxx.xxx	Recommended; If you entered an IP address, then enter a subnet mask compatible with your network.

Where to Go From Here

The above procedure configures your switch with a Manager password, IP address, and subnet mask. As a result, with the proper network connections, you can now manage the switch from a PC equipped with Telnet, and/or a web browser interface.

Some basic information on managing your switch is included in the next section. For more information on the console, web browser, and SNMP management interfaces and all the features that can be configured on the Switches 2600 Series, please see the *Management and Configuration Guide*, which is on the Documentation CD-ROM that came with your switch.

To Recover from a Lost Manager Password: If you cannot start a console session at the manager level because of a lost Manager password, you can clear all passwords and user names by getting physical access to the switch and pressing and holding the Clear button for a full second.

Using the IP Address for Remote Switch Management

With your switch, you can use the switch's IP address to manage the switch from any PC that is on the same subnet as the switch. You can use either a Telnet session or a standard web browser to manage the switch.

Starting a Telnet Session

To access the switch through a Telnet session, follow these steps:

1. Make sure the switch is configured with an IP address and that the switch is reachable from the PC that is running the Telnet session (for example, by using a Ping command to the switch's IP address).
2. Start the Telnet program on a PC that is on the same subnet as the switch and connect to the switch's IP address.
3. You will see the copyright page and the message "Press any key to continue". Press a key, and you will then see the switch console command (CLI) prompt, for example:

HP ProCurve Switch 2650#

Enter **help** or **?** to see a list of commands that can be executed at the prompt. Entering any command followed by **help** provides more detailed context help information about the command. Entering any command followed by **?** displays a list of options that are available at that point in the command entry.

Starting a Web Browser Session

The Switches 2600 Series can be managed through a graphical interface that you can access from any PC or workstation on the network by running your web browser and typing in the switch's IP address as the URL. No additional software installation is required to make this interface available; it is included in the switch's onboard software.

A typical web browser interface screen is shown in the next illustration.

Configuring the Switch

Using the IP Address for Remote Switch Management

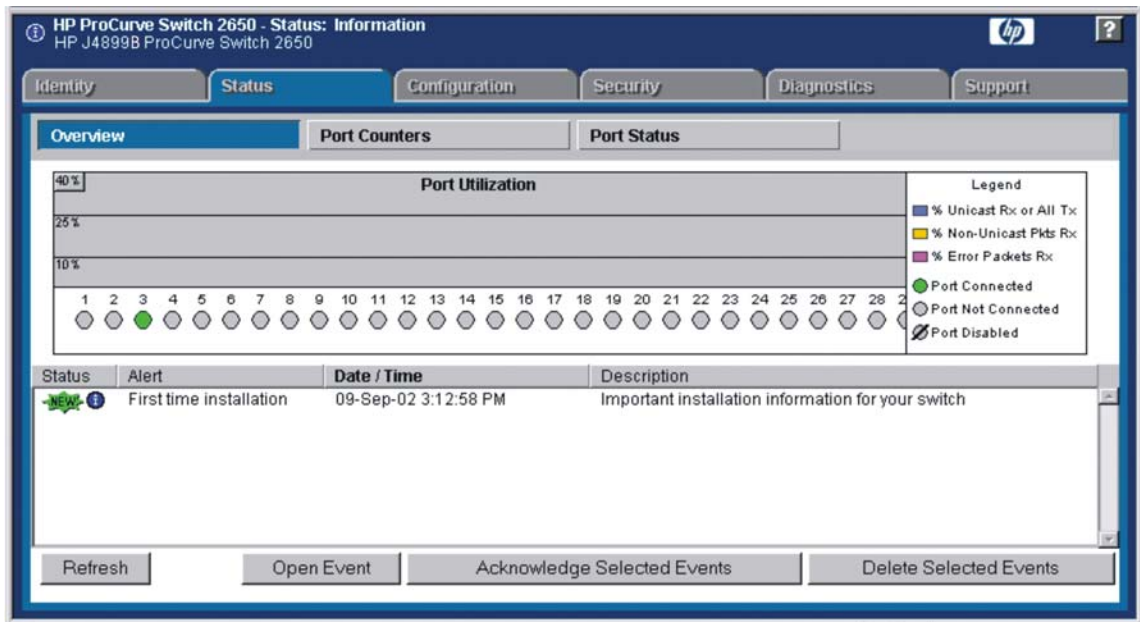

For more information on using the web browser interface, please see the *Management and Configuration Guide*, which is on the Documentation CD-ROM that came with your switch.

An extensive help system is also available for the web browser interface. To access the help system though, the subnet on which the switch is installed must have access to the internet.

Troubleshooting

This chapter describes how to troubleshoot your HP ProCurve Switch 2600 and Switch 2600-PWR Series devices. This document describes troubleshooting mostly from a hardware perspective. You can perform more in-depth troubleshooting on these devices using the software tools available with the switches, including the full-featured console interface, the built-in web browser interface, and HP ProCurve Manager, the SNMP-based network management tool. For more information, see the chapter “Troubleshooting” in the *Management and Configuration Guide*, which is on the Documentation CD-ROM that came with your switch.

This chapter describes the following:

- basic troubleshooting tips ([page 4-1](#))
 - diagnosing with the LEDs ([page 4-4](#))
 - Proactive Networking tools ([page 4-8](#))
 - hardware diagnostic tests ([page 4-9](#))
 - restoring the factory default configuration ([page 4-11](#))
 - downloading new software to the Switch 2600 Series ([page 4-12](#))
 - HP Customer Support Services ([page 4-12](#))
-

Basic Troubleshooting Tips

Most problems are caused by the following situations. Check for these items first when starting your troubleshooting:

- **Connecting to devices that have a fixed full-duplex configuration.** The RJ-45 ports are configured as “Auto”. That is, when connecting to attached devices, the switch operates in one of two ways to determine the link speed and the communication mode (half duplex or full duplex):
 - If the connected device is also configured to Auto, the switch will automatically negotiate both link speed and communication mode.

- If the connected device has a fixed configuration, for example 100 Mbps, at half or full duplex, the switch will automatically sense the link speed, but will default to a communication mode of half duplex.

Caution

Because the Switches 2600 Series behave in this way (*in compliance with the IEEE 802.3 standard*), if a device connected to the switch has a fixed configuration at full duplex, the device will not connect correctly to the switch. The result will be high error rates and very inefficient communications between the switch and the device.

Ensure all devices connected to the Switch 2600 Series devices are configured to auto negotiate, or are configured to connect at half duplex (all hubs are configured this way, for example).

- **Faulty or loose cables.** Look for loose or obviously faulty connections. If the cables appear to be OK, make sure the connections are snug. If that does not correct the problem, try a different cable.
- **Non-standard cables.** Non-standard and miswired cables may cause network collisions and other network problems, and can seriously impair network performance. Use a new correctly-wired cable or compare your cable to the cable in appendix B, “Switch Ports and Network Cables” for pinouts and correct cable wiring. A category 5 cable tester is a recommended tool for every 100Base-TX and 1000Base-T network installation.
- **Improper Network Topologies.** It is important to make sure you have a valid network topology. Common topology faults include excessive cable length and excessive repeater delays between end nodes. If you have network problems after recent changes to the network, change back to the previous topology. If you no longer experience the problems, the new topology is probably at fault. Sample topologies are shown at the end of chapter 2 in this book, and some topology configuration guidelines can be found online at the HP ProCurve web site, <http://www.hp.com/go/hpprocurve>.

In addition, you should make sure that your network topology contains **no data path loops**. Between any two end nodes, there should be only one active cabling path at any time. Data path loops will cause broadcast storms that will severely impact your network performance.

For your Switch, if you wish to build redundant paths between important nodes in your network to provide some fault tolerance, you should enable **Spanning Tree Protocol** support on the switch. This ensures that only one of the redundant paths is active at any time, thus avoiding data path loops. Spanning Tree can be enabled through the switch console or the web browser interface.

The Switch 2600 Series devices also support **Trunking**, which allows multiple network cables to be used for a single network connection without causing a data path loop. For more information on Spanning Tree and Trunking, see the *Management and Configuration Guide*, which is on the Documentation CD-ROM that came with your switch.

- **Check the port configuration.** A port on your switch may not be operating as you expect because it has been put into a “blocking” state by Spanning Tree, GVRP (automatic VLANs), or LACP (automatic trunking). (Note that the normal operation of the Spanning Tree, GVRP, and LACP features may put the port in a blocking state.) Or, the port just may have been configured as disabled through software.

Use the switch console to determine the port’s configuration and verify that there is not an improper or undesired configuration of any of the switch features that may be affecting the port. For more information, see the *Management and Configuration Guide*, which is on the Documentation CD-ROM that came with your switch.

For more information on possible network problems and their solutions, refer to the technical note “Troubleshooting LAN Performance and Intermittent Connectivity Problems”, which can be found on the HP ProCurve web site, <http://www.hp.com/go/hpprocurve>, in the Information Library section.

Diagnosing with the LEDs

Table 4-1 shows LED patterns on the switch and the switch modules that indicate problem conditions.

1. Check in the table for the LED pattern you see on your switch.
2. Refer to the corresponding diagnostic tip on the next few pages.

Table 4-1. LED Error Indicators

LED Pattern Indicating Problems							Diagnostic Tips
Power	Fault	RPS	EPS	Self Test	Fan Status	Port LED (in Link view mode)	
Off with power cord plugged in	*	*	*	*	*	*	1
On	Prolonged On	*	*	Prolonged On	*	*	2
On	Blinking [†]	*	*	Blinking [†]	*	*	3
On	Blinking [†]	*	*	Off	Blinking [†]	*	4
On	Blinking [†]	*	*	Blinking [†]	*	Blinking [†]	5
On	Off	*	*	Off	*	Off with cable connected	6
On	Off	*	*	Off	*	On, but the port is not communicating	7
On	Blinking	Blinking	Blinking		*	*	8

* This LED is not important for the diagnosis.
[†] The blinking behavior is an on/off cycle once every 1.6 seconds, approximately.

Diagnostic Tips:

Tip	Problem	Solution
1	The switch is not plugged into an active AC power source, or the switch's power supply may have failed.	<ol style="list-style-type: none"> 1. Verify the power cord is plugged into an active power source and to the switch. Make sure these connections are snug. 2. Try power cycling the switch by unplugging and plugging the power cord back in. 3. If the Power LED is still not on, verify the AC power source works by plugging another device into the outlet. Or try plugging the switch into a different outlet or try a different power cord. <p>If the power source and power cord are OK and this condition persists, the switch power supply may have failed. Call your HP-authorized LAN dealer, or use the electronic support services from HP to get assistance. See the Customer Support/Warranty booklet for more information.</p>
2	A switch hardware failure has occurred. All the LEDs will stay on indefinitely.	<p>Try power cycling the switch. If the fault indication reoccurs, the switch may have failed. Call your HP-authorized LAN dealer, or use the electronic support services from HP to get assistance. See the Customer Support/Warranty booklet for more information.</p>
3	The switch has experienced a software failure during self test.	<ol style="list-style-type: none"> 1. Try resetting the switch by pressing the Reset button on the front of the switch, or by power cycling the switch. 2. If the fault indication reoccurs, attach a console to the switch (as indicated in chapter 2) and configure it to operate at 9600 baud. Then, reset the switch. Messages should appear on the console screen and in the console log identifying the error condition. You can view the console log at that point by selecting it from the console Main Menu. <p>If necessary to resolve the problem, contact your HP-authorized LAN dealer, or use the electronic support services from HP to get assistance. See the Customer Support/Warranty booklet for more information.</p>
4	One or both of the switch cooling fans may have failed.	<p>Try disconnecting power from the switch and wait a few moments. Then reconnect the power to the switch and check the LEDs again. If the error indication reoccurs, one or both of the fans has failed. The switch has two fans and may continue to operate under this condition if the ambient temperature does not exceed normal room temperature, but for best operation, the switch should be replaced. Contact your HP-authorized LAN dealer, or use the electronic support services from HP to get assistance. See the Customer Support/Warranty booklet for more information.</p>
5	The network port for which the LED is blinking has experienced a self test or initialization failure.	<p>Try power cycling the switch. If the fault indication reoccurs, the switch port may have failed. Call your HP-authorized LAN dealer, or use the electronic support services from HP to get assistance. See the Customer Support/Warranty booklet for more information.</p> <p>If the port is a mini-GBIC, verify that it is one of the mini-GBICs supported by the switch. Unsupported mini-GBICs will be identified with this fault condition. The supported mini-GBICs are listed in Chapter 2, "Installing the Switch" on page 2-7. The mini-GBICs are also tested when they are "hot-swapped"—installed or changed while the switch is powered on.</p> <p>To verify that the port has failed, try removing and reinstalling the mini-GBIC without having to power off the switch. If the port fault indication reoccurs, you will have to replace the mini-GBIC.</p>

continued on the next page

Tip	Problem	Solution
⑥	The network connection is not working properly.	<p>Try the following procedures:</p> <ul style="list-style-type: none">• For the indicated port, verify that both ends of the cabling, at the switch and the connected device, are connected properly.• Verify the connected device and switch are both powered <i>on</i> and operating correctly.• Verify you have used the correct cable type for the connection:<ul style="list-style-type: none">– For twisted-pair connections to the fixed 10/100 or 10/100/1000 ports, if the port is configured to “Auto” (auto negotiate), either straight-through or crossover cables can be used because of the switch’s “HP Auto-MDIX” feature and the Auto MDI/MDI-X feature of the 10/100/1000-T port. <hr/> <p>Note: If the switch port configuration is changed to one of the fixed configuration options (for example, 100 Mbps/Full Duplex), then the port operates as MDI-X only and you must use the correct type of cable for the connection. In general, for connecting an end node (MDI port) to the switch, use straight-through cable; for connecting to MDI-X ports on hubs, other switches, and routers, use crossover cable.</p> <hr/> <ul style="list-style-type: none">– For fiber-optic connections, verify that the transmit port on the switch is connected to the receive port on the connected device, and the switch receive port is connected to the transmit port on the connected device.• For the dual-personality 10/100/1000-T ports, be sure a mini-GBIC is not installed in the associated slot.• For 1000Base-T connections, verify that the network cabling complies with the IEEE 802.3ab standard. the cable should be installed according to the ANSI/TIA/EIA-568-A-5 specifications. Cable testing should comply with the stated limitations for Attenuation, Near-End Crosstalk, Far-End Crosstalk, Equal-Level Far-End Crosstalk (ELFEXT), Multiple Disturber ELFEXT, and Return Loss. The cable verification process must include all patch cables from any end devices, including the switch, to any patch panels in the cabling path.• Verify the port has not been disabled through a switch configuration change. You can use the console interface, or, if you have configured an IP address on the switch, use the web browser interface to determine the state of the port and re-enable the port if necessary.• Verify the switch port configuration matches the configuration of the attached device. For example, if the switch port is configured as “Auto”, the port on the attached device also MUST be configured as “Auto”. Depending on the port type, twisted-pair or fiber-optic, if the configurations don’t match, the results could be a very unreliable connection, or no link at all.• If the other procedures don’t resolve the problem, try using a different port or a different cable.

Tip	Problem	Solution
7	The port may be improperly configured, or the port may be in a “blocking” state by the normal operation of the Spanning Tree, LACP, or IGMP features.	<p>Use the switch console to see if the port is part of a dynamic trunk (through the LACP feature) or to see if Spanning Tree is enabled on the switch, and to see if the port may have been put into a “blocking” state by those features. The show lacp command displays the port status for the LACP feature; the show spanning-tree command displays the port status for Spanning Tree.</p> <p>Also check the Port Status screen using the show interfaces command to see if the port has been configured as “disabled”.</p> <p>Other switch features that may affect the port operation include VLANs and IGMP. Use the switch console to see how the port is configured for these features.</p> <p>For software troubleshooting tips, see the chapter “Troubleshooting” in the <i>Management and Configuration Guide</i>, which is on the Documentation CD-ROM that came with your switch.</p> <p>Ensure also, that the device at the other end of the connection is indicating a good link to the switch. If it is not, the problem may be with the cabling between the devices or the connectors on the cable.</p>
8	RPS or EPS is connected but has experienced a fault.	Refer to the HP 600/610 External Power Supplies documentation.

Proactive Networking

The HP ProCurve Switch 2600 Series devices have built-in management capabilities that proactively help you manage your network including:

- finding and helping you fix the most common network error conditions (for example, faulty network cabling, and non-standard network topologies)
- informing you of the problem with clear, easy-to-understand messages
- recommending network configuration changes to enhance the performance of your network

The following interfaces provide tests, indicators, and an event log that can be used to monitor the switch and its network connections and to help you take advantage of these proactive networking features:

- A graphical web browser interface you can use to manage your switch from a PC running a supported web browser, for example Microsoft Internet Explorer, and Netscape Communicator.
- A full-featured easy-to-use console interface you can access by connecting a standard terminal or PC running a terminal emulator to the switch's console port. The cable to make that connection is provided with your switch. If an IP address has been assigned, the console interface is also accessible through a Telnet connection.

For more information on using these software tools to diagnose and manage your switch, see the “Troubleshooting” chapter in the *Management and Configuration Guide*, which is on the Documentation CD-ROM that came with your switch.

Hardware Diagnostic Tests

Testing the Switch by Resetting It

If you believe the switch is not operating correctly, you can reset the switch to test its circuitry and operating code. To reset a switch, either:

- Unplug and plug in the power cord (power cycling)
- Press the Reset button on the front of the switch

Power cycling the switch and pressing the Reset button both cause the switch to perform its power-on self test, which almost always will resolve any temporary operational problems. These reset processes also cause any network traffic counters to be reset to zero, and cause the System Up Time timer to reset to zero.

Checking the Switch LEDs

The self test passes if the Fault and Self Test LEDs on the front of the switch go off after approximately 50 seconds. If these LEDs stay on longer than 60 seconds or begin blinking, there may be a problem with the switch.

See “Diagnosing With the LEDs” on [page 4-4](#) for information on interpreting the LED patterns.

Checking Console Messages

Useful diagnostic messages may be displayed on the console screen when the switch is reset. As described in chapter 2 under step 7, Connect a Console to the Switch connect a PC running a VT-100 terminal emulator program or a standard VT-100 terminal to the switch’s Console Port and configure it to run at 9600 baud, and with the other terminal communication settings shown on “[Configuring the Switch](#)”. Then, when you reset the switch, note the messages that are displayed. Additionally, you can check the switch event log, which can be accessed from the console using the **show log** command, or from the console Main Menu after entering the **Menu** command.

Testing Twisted-Pair Cabling

Network cables that fail to provide a link or provide an unreliable link between the switch and the connected network device may not be compatible with the IEEE 802.3 Type 10Base-T, 100Base-TX, or 1000Base-T standards. The twisted-pair cables attached to the switch must be compatible with the appropriate standards. To verify your cable is compatible with these standards, use a qualified cable test device.

Testing Switch-to-Device Network Communications

You can perform the following communication tests to verify the network is operating correctly between the switch and any connected device that can respond correctly to the communication test.

- **Link Test** – a physical layer test that sends IEEE 802.2 test packets to any device identified by its MAC address
- **Ping Test** – a network layer test used on IP networks that sends test packets to any device identified by its IP address

These tests can be performed through the switch console interface from a terminal connected to the switch or through a Telnet connection, or from the switch's web browser interface. For more information, see the *Management and Configuration Guide*, which is on the Documentation CD-ROM that came with your switch.

Testing End-to-End Network Communications

Both the switch and the cabling can be tested by running an end-to-end communications test – a test that sends known data from one network device to another through the switch. For example, if you have two PCs on the network that have LAN adapters between which you can run a link-level test or Ping test through the switch, you can use this test to verify that the entire communication path between the two PCs is functioning correctly. See your LAN adapter documentation for more information on running a link test or Ping test.

Restoring the Factory Default Configuration

As part of your troubleshooting process on the Switch, it may become necessary to return the switch configuration to the factory default settings. This clears any passwords, clears the console event log, resets the network counters to zero, performs a complete self test, and reboots the switch into its factory default configuration including deleting the IP address, if one is configured.

Note

This process removes all switch configuration changes that you have made from the factory default settings. This includes, for example, configuration of VLANs, Spanning Tree, trunks, and stacking. Returning the configuration of these features to their factory default settings (usually disabling them) may result in network connectivity issues.

If the switch has a valid configuration, and you are restoring the factory default settings for a reason other than configuration problems, you should save the switch configuration prior to performing the factory default reset. Then, after the reset and resolution of the original problem, you can restore the saved configuration to the switch. For both the save and restore processes, you can use the console **copy** command. For more information on this command, see the *Management and Configuration Guide*, which is on the Documentation CD-ROM that came with your switch.

You can restore the factory default configuration either on the switch itself, or through the switch console.

To execute the factory default reset on the switch, perform these steps:

1. Using pointed objects, simultaneously press both the Reset and Clear buttons on the front of the switch. The power and fault lights come on.
2. Continue to press the Clear button while releasing the Reset button.
3. When the Self Test LED begins to blink, release the Clear button.

The switch will then complete its self test and begin operating with its configuration restored to the factory default settings.

To restore the factory default configuration using the console, execute the **erase startup-config** command from the console command prompt.

Downloading New Switch Software

When product enhancements occur for the Switch 2600 Series devices, new software can be downloaded to the switch through several methods, for product enhancements and new features. For more information, see the *Management and Configuration Guide*, which is on the Documentation CD-ROM that came with your switch.

The new switch software would be available on the HP ProCurve web site, <http://www.hp.com/go/hpprocurve>.

HP Customer Support Services

If you are still having trouble with your switch, Hewlett-Packard offers support 24 hours a day, seven days a week through the use of a number of automated electronic services. See the Customer Support/Warranty booklet that came with your switch for information on how to use these services to get technical support. The HP ProCurve web site, <http://www.hp.com/go/hpprocurve> also provides up-to-date support information.

Additionally, your HP-authorized network reseller can provide you with assistance, both with services that they offer and with services offered by HP.

Before Calling Support

Before calling your networking dealer or HP Support, to make the support process most efficient, you first should retrieve the following information:

Information Item	Information Location
• product identification, including mini-GBICs	the front of the switch and on labels on the mini-GBICs
• details about the switch's status including the software (OS) version, a copy of the switch configuration, a copy of the switch Event Log, and a copy of the switch status and counters information	switch console: show tech command
• copy of your network topology map, including network addresses assigned to the relevant devices	your network records

Switch Specifications

Physical

	2626 (J4900B)	2626-PWR (J8164A)	2650 (J4899B)	2650-PWR (J8165A)
Width:	44.3 cm (17.42 in)	44 cm (17.0 in)	44.3 cm (17.42 in)	44 cm (17.0 in)
Depth:	36.7 cm (14.4 in)	48.3 cm (19.0 in)	43.0 cm (16.9 in)	48.3 cm (19.0 in)
Height:	4.4 cm (1.73 in)	4.4 cm (1.73 in)	4.4 cm (1.73 in)	4.4 cm (1.73 in)
Weight:	4.62 kg (10.20 lbs)	6.84 kg (15.05 lbs)	4.88 kg (10.75 lbs)	7.58 kg (16.70 lbs)

Electrical

The switch automatically adjusts to any voltage between 100-240 volts and either 50 or 60 Hz.

	2626 (J4900B)	2626-PWR (J8164A)	2650 (J4899B)	2650-PWR (J8165A)
AC voltage:	100/240 volts	100/240 volts	100/240 volts	100/240 volts
Maximum current:	0.6A/0.3A	7.5A/3.5A	0.8A/0.4A	7.5A/3.5A
Frequency range:	50/60 Hz	50/60 Hz	50/60 Hz	50/60 Hz

Environmental

2600 Series	Operating	Non-Operating
Temperature:	0°C to 55°C (32°F to 131°F)	-40°C to 70°C (-40°F to 158°F)
Relative humidity: (non-condensing)	15% to 95% at 40°C (104°F)	15% to 90% at 65°C (149°F)
Maximum altitude:	4.6 Km (15,000 ft)	4.6 Km (15,000 ft)
2600-PWR Series	Operating	Non-Operating
Temperature:	0°C to 50°C (32°F to 122°F)	-40°C to 70°C (-40°F to 158°F)
Relative humidity: (non-condensing)	15% to 95% at 40°C (104°F)	15% to 90% at 65°C (149°F)

Acoustic

Non-PWR 2600 Series (J4899B/J4900B):

Geraeuschemission LwA=62 dB am fiktiven Arbeitsplatz nach DIN 45635 T.19
Noise Emission LwA=62 dB at virtual work space according to DIN 45635 T.19

2600 PWR Series (J8164A/J8165A):

Geraeuschemission LwA=53 dB am fiktiven Arbeitsplatz nach DIN 45635 T.19
Noise Emission LwA=53 dB at virtual work space according to DIN 45635 T.19

Connectors

- The 10/100/1000 Mbps RJ-45 twisted-pair ports are compatible with the following standards:
 - IEEE 802.3ab 1000Base-T
 - IEEE 802.3u 100Base-TX
 - IEEE 802.3 10Base-T
- The 1000 Mbps LC fiber-optic ports on the Gigabit-SX and Gigabit-LX mini-GBIC transceivers are compatible with the IEEE 802.3z Gigabit-SX and Gigabit-LX standards.
- EPS connector: A 2x7 Molex Micro-Fit connector should be used for EPS connection.
- RPS connector: A 2x7 connector is provided for external RPS connection on the power supply module.

Safety

Complies with:

- EN60950 / IEC 950
- CSA 22.2 No. 950
- UL 60950

Lasers

The Gigabit-SX LC mini-GBIC, and the Gigabit-LX LC mini-GBIC, both of which can be installed in the Switch 2600 Series devices, are Class 1 Laser Products.

Laser Klasse 1

These mini-GBICs comply with IEC 825-2: 1993.

Switch Ports and Network Cables

This appendix includes switch connector information and network cable information for cables that should be used with the Switch 2600 and 2600-PWR Series devices, including minimum pin-out information and specifications for twisted-pair cables.

Note

Incorrectly wired cabling is the most common cause of problems for LAN communications. HP recommends that you work with a qualified LAN cable installer for assistance with your cabling requirements.

Switch Ports

The fixed RJ-45 10/100/1000Base-T ports on the switch accept 100-ohm unshielded and shielded twisted-pair cable with RJ-45 connectors as described on the next page.

Twisted-Pair Cables

10 Mbps Operation	Category 3, 4, or 5 100-ohm unshielded twisted-pair (UTP) or shielded twisted-pair (STP) cable, complying with IEEE 802.3 Type 10Base-T specifications, fitted with RJ-45 connectors
100 Mbps Operation	Category 5 100-ohm UTP or STP cable, complying with IEEE 802.3u 100Base-TX specifications, fitted with RJ-45 connectors
1000 Mbps Operation	Category 5 100-ohm 4-pair UTP or STP cable, complying with IEEE 802.3ab 1000Base-T specifications, fitted with RJ-45 connectors—Category 5e or better is recommended (<i>please see “Note on 1000Base-T Cable Requirements”, below</i>)

Note on 1000Base-T Cable Requirements. The Category 5 networking cables that work for 100Base-TX connections should also work for 1000Base-T, as long as all four-pairs are connected. But, for the most robust connections you should use cabling that complies with the Category 5e specifications, as described in Addendum 5 to the TIA-568-A standard (ANSI/TIA/EIA-568-A-5).

Because of the increased speed provided by 1000Base-T (Gigabit-T), network cable quality is more important than for either 10Base-T or 100Base-TX. Cabling plants being used to carry 1000Base-T networking must comply with the IEEE 802.3ab standards. In particular, the cabling must pass tests for Attenuation, Near-End Crosstalk (NEXT), and Far-End Crosstalk (FEXT). Additionally, unlike the cables for 100Base-TX, the 1000Base-T cables must pass tests for Equal-Level Far-End Crosstalk (ELFEXT) and Return Loss.

When testing your cabling, be sure to include the patch cables that connect the switch and other end devices to the patch panels on your site. The patch cables are frequently overlooked when testing cable and they must also comply with the cabling standards.

Fiber-Optic Cables

Port Type	Cable Specifications	Connector Type	Maximum Length
Gigabit-SX	62.5/125 mm or 50/125 μm (core/cladding) diameter, graded-index, low metal content, multimode fiber-optic cables, complying with the ITU-T G.651 and ISO/IEC 793-2 Type A1b or A1a respectively.	LC - Gigabit-SX mini-GBIC SC - Gigabit-SX transceiver	<ul style="list-style-type: none"> • 62.5 μm cable: <ul style="list-style-type: none"> – 160 MHz*km=220 meters – 200 MHz*km=275 meters • 50 μm cable: <ul style="list-style-type: none"> – 400 MHz*km=500 meters – 500 MHz*km=550 meters
Gigabit-LX	9/125 μm (core/cladding) diameter, graded-in 1310 nm, low metal content, single mode fiber-optic cables, complying with the ITU-T G.652 and ISO/IEC 793-2 Type B1 standards. OR the multimode fiber-optic cables listed for Gigabit-SX.	LC - Gigabit-LX mini-GBIC SC - Gigabit-LX transceiver	<ul style="list-style-type: none"> • single-mode cable: 10 kilometers • Multimode cable: 550 meters
<p>Note: To use multimode cables for Gigabit-LX, a mode conditioning patch cord may be needed - See "Mode Conditioning Patch Cord for Gigabit-LX" on page B-3 for more information.</p>			
Gigabit-LH	9/125 mm (core/cladding) diameter, graded-in 1550 nm, low metal content, single mode fiber-optic cables, complying with the ITU-T G.652 and ISO/IEC 793-2 Type B1 standards.	LC - Gigabit-LH mini-GBIC	70 kilometers
<p>Note: Between the transmit and receive ends of the cable, at least 5db of attenuation is required for a reliable connection. This is equivalent to 20Km of the fiber-optic cable. For distances less than 20Km, you must add attenuators to bring the total attenuation to at least 5db. Most cable vendors carry attenuators.</p>			

Mode Conditioning Patch Cord for Gigabit-LX

The following information applies to installations in which multimode fiber-optic cables are connected to a Gigabit-LX port.

Unlike Gigabit-SX, which connects to only multimode fiber-optic cabling, Gigabit-LX can use either single-mode or multimode cable. Multimode cable has a design characteristic called “Differential Mode Delay”, which requires that the transmission signals be “conditioned” to compensate for the cable design and thus prevent resulting transmission errors. Since Gigabit-SX is designed to operate only with multimode cable, Gigabit-SX mini-GBICs can provide that transmission conditioning internally.

Gigabit-LX mini-GBICs, since they are designed to operate with both single-mode and multimode cable, do not provide the transmission conditioning internally. Thus, under certain circumstances, depending on the cable used and the lengths of the cable runs, an external **Mode Conditioning Patch Cord** may need to be installed between the Gigabit-LX transmitting device and the multimode network cable to provide the transmission conditioning.

If you experience a high number of transmission errors on the Gigabit-LX ports, usually CRC or FCS errors, you may need to install one of these patch cords between the Gigabit-LX port in your switch and your multimode fiber-optic network cabling, *and between the Gigabit-LX transmission device and the network cabling at the other end of the multimode fiber-optic cable run. A patch cord must be installed at both ends.*

The patch cord consists of a short length of single-mode fiber cable coupled to graded-index multimode fiber cable on the transmit side, and only multimode cable on the receive side. The section of single-mode fiber is connected in such a way that it minimizes the effects of the differential mode delay in the multimode cable.

Note

Most of the time, if you are using good quality graded-index multimode fiber cable that adheres to the standards listed on [page 2-6](#), there should not be a need to use mode conditioning patch cords in your network. This is especially true if the fiber runs in your network are relatively short.

If you are using *single-mode* fiber-optic cabling in your network, there is no need to use mode conditioning patch cords. Connect the single-mode network cable directly to the Gigabit-LX mini-GBIC.

Installing the Patch Cord

As shown in the illustration below, connect the patch cord to the Gigabit-LX mini-GBIC with the section of single-mode fiber plugged in to the Tx (transmit) port. Then, connect the other end of the patch cord to your network cabling patch panel, or directly to the network multimode fiber.

If you connect the patch cord directly to the network cabling, you may need to install a **female-to-female adapter** to allow the cables to be connected together.

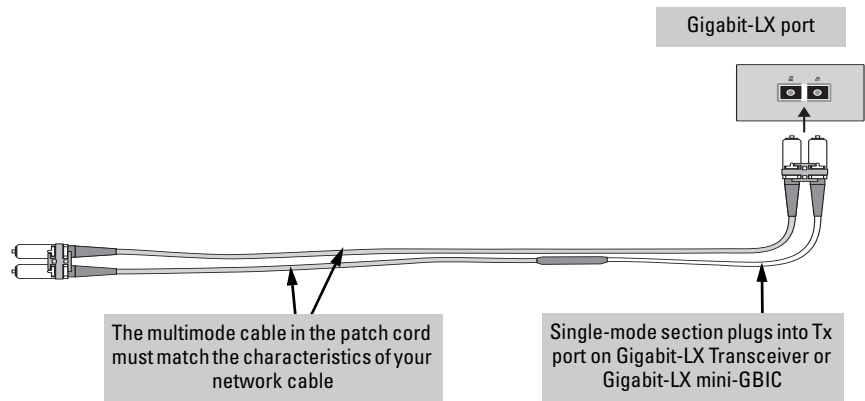

Make sure you purchase a patch cord that has LC connectors on the end that connects to the Gigabit-LX mini-GBIC, and has multimode fibers that match the characteristics of the multimode fiber in your network.

Recommended Patch Cords

Hewlett-Packard maintains a list of recommended Mode Conditioning Patch Cords that have been tested and verified to operate correctly with the HP ProCurve Gigabit-LX Transceiver and HP ProCurve Gigabit-LX LC mini-GBIC.

The list is on the HP ProCurve web site, <http://www.hp.com/go/hpprocurve>, in the Technical Support section.

Twisted-Pair Cable/Connector Pin-Outs

The HP Auto-MDIX Feature: In the default configuration, “Auto”, the fixed 10/100Base-TX ports on the Series 2600 Switches all automatically detect the type of port on the connected device and operate as either an MDI or MDI-X port, whichever is appropriate. So for any connection, a straight-through twisted-pair cable can be used – *you no longer have to use crossover cables*, although crossover cables can also be used for any of the connections. (The 10/100/1000-T ports support the IEEE 802.3ab standard, which includes the “Auto MDI/MDI-X” feature, which operates the same way.)

If you connect a Switch 2600 or 2600-PWR Series device’s twisted-pair port to another switch or hub, which typically have MDI-X ports, the Switch 2600-PWR Series device port automatically operates as an MDI port. If you connect it to an end node, such as a server or PC, which typically have MDI ports, the Switch 2600-PWR Series device’s port operates as an MDI-X port. In all cases, you can use standard straight through cables or crossover cables.

If you happen to use a correctly wired crossover cable, though, the switch will still be able to automatically detect the MDI/MDI-X operation and link correctly to the connected device.

Note

Using Fixed Configurations. If the port configuration is changed to any of the fixed configurations though, for example 100 Mbps/full duplex, the port operates as MDI-X only and the correct cable type must be used: for connections to MDI ports, such as end nodes, use a straight-through cable; for connections to MDI-X ports, such as on hubs and other switches, use a crossover cable.

Other Wiring Rules:

- All twisted-pair wires used for 10 Mbps, and 100 Mbps operation must be twisted through the entire length of the cable. The wiring sequence must conform to EIA/TIA 568-B (not USOC). See “Twisted-Pair Cable Pin Assignments” later in this appendix for a listing of the signals used on each pin.
- For 1000Base-T connections, all four pairs of wires in the cable must be available for data transmission. *Please see “[Note on 1000Base-T Cable Requirements](#)” on page B-1 for more information on 1000Base-T cabling.*
- For 10 Mbps connections to the ports, you can use Category 3, 4, or 5 unshielded twisted-pair cable, as supported by the IEEE 802.3 Type 10Base-T standard.

Switch Ports and Network Cables

Twisted-Pair Cable/Connector Pin-Outs

- For 100 Mbps connections to the ports, use 100-ohm Category 5 UTP or STP cable only, as supported by the IEEE 802.3u Type 100Base-TX standard.
- For 1000 Mbps connections, 100-ohm Category 5e or better cabling is recommended.
- To provide Power over Ethernet to the access point, all 4 pairs must be connected for any network cable attached to this port; the cable must meet ISO/DIS 11801 Class D requirements and IEEE 802.3af requirements.

Straight-Through Twisted-Pair Cable for 10 Mbps or 100 Mbps Network Connections

Because of the HP Auto-MDIX operation of the 10/100 ports on the switch, for all network connections, to PCs, servers or other end nodes, or to hubs or other switches, you can use straight-through cables.

If any of these ports are given a fixed configuration, for example 100 Mbps/ Full Duplex, the ports operate as MDI-X ports, and straight-through cables must be then used for connections to PC NICs and other MDI ports.

Cable Diagram

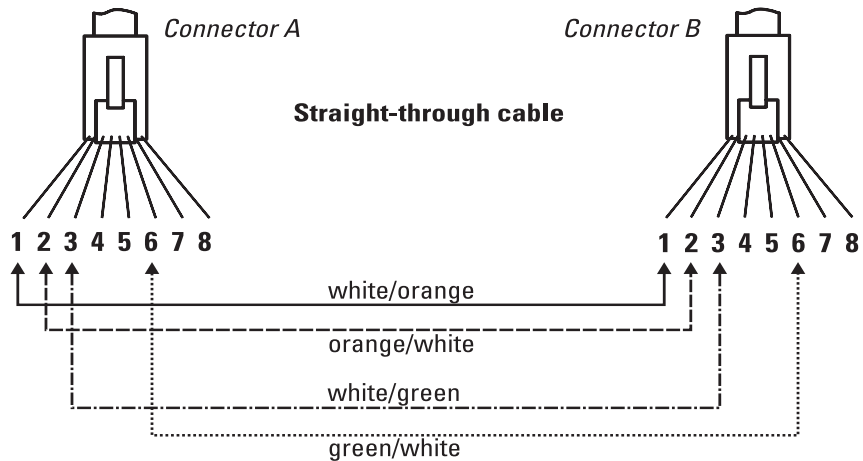

Note

Pins 1 and 2 on connector “A” *must* be wired as a twisted pair to pins 1 and 2 on connector “B”.

Pins 3 and 6 on connector “A” *must* be wired as a twisted pair to pins 3 and 6 on connector “B”.

Pins 4, 5, 7, and 8 are not used in this application, although they may be wired in the cable.

Pin Assignments

Switch End (MDI-X)		Computer, Transceiver, or Other End	
Signal	Pins	Pins	Signal
receive +	1 ←	1	transmit +
receive -	2 ←	2	transmit -
transmit +	3 →	3	receive +
transmit -	6 →	6	receive -

Crossover Twisted-Pair Cable for 10 Mbps or 100 Mbps Network Connection

The HP Auto-MDIX operation of the 10/100 ports on the switch also allows you to use crossover cables for all network connections, to PCs, servers or other end nodes, or to hubs or other switches.

If any of these ports are given a fixed configuration, for example 100 Mbps/ Full Duplex, the ports operate as MDI-X ports, and crossover cables *must* be then used for connections to hubs or switches or other MDI-X network devices.

Cable Diagram

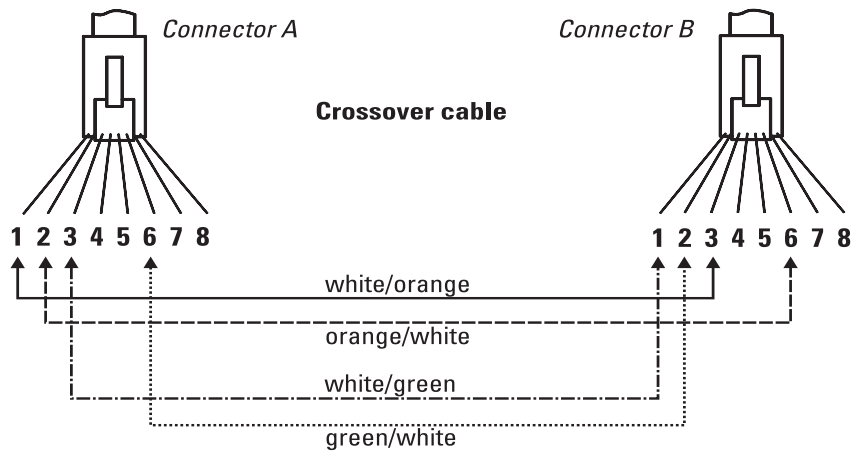

Note

Pins 1 and 2 on connector “A” *must* be wired as a twisted pair to pins 3 and 6 on connector “B”.

Pins 3 and 6 on connector “A” *must* be wired as a twisted pair to pins 1 and 2 on connector “B”.

Pins 4, 5, 7, and 8 are not used in this application, although they may be wired in the cable.

Pin Assignments

Switch End (MDI-X)		Hub or Switch Port, or Other MDI-X Port End	
Signal	Pins	Pins	Signal
receive +	1	6	transmit -
receive -	2	3	transmit +
transmit +	3	2	receive -
transmit -	6	1	receive +

Straight-Through Twisted-Pair Cable for 1000 Mbps Network Connections

1000Base-T connections require that all four pairs of wires be connected.

Cable Diagram

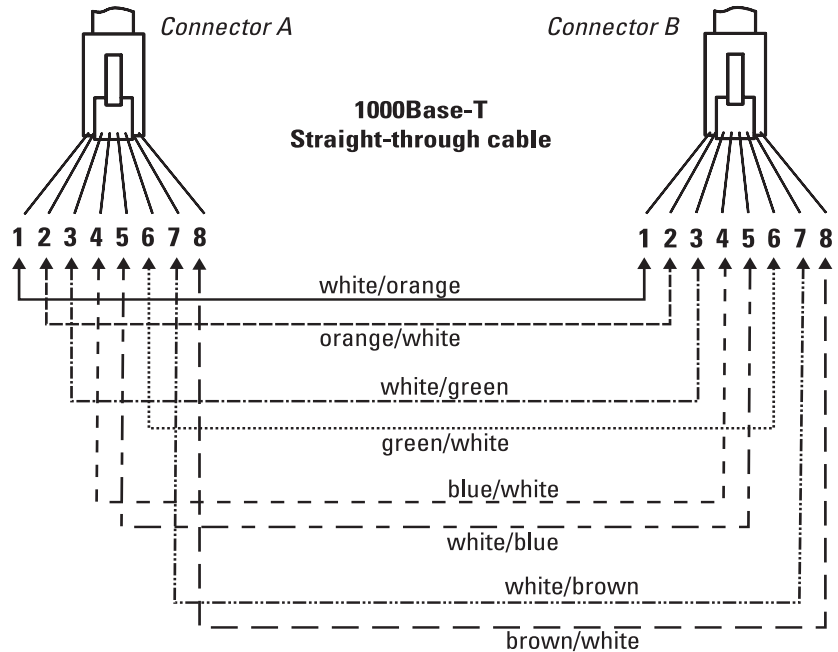

Note

Pins 1 and 2 on connector "A" *must* be wired as a twisted pair to pins 1 and 2 on connector "B".

Pins 3 and 6 on connector "A" *must* be wired as a twisted pair to pins 3 and 6 on connector "B".

Pins 4 and 5 on connector "A" *must* be wired as a twisted pair to pins 4 and 5 on connector "B".

Pins 7 and 8 on connector "A" *must* be wired as a twisted pair to pins 7 and 8 on connector "B".

Pin Assignments

For 1000Base-T operation, all four pairs of wires are used for both transmit and receive.

— *This page is intentionally unused.* —

Safety and EMC Regulatory Statements

Safety Information



Documentation reference symbol. If the product is marked with this symbol, refer to the product documentation to get more information about the product.

WARNING

A WARNING in the manual denotes a hazard that can cause injury or death.

Caution

A Caution in the manual denotes a hazard that can damage equipment.

Do not proceed beyond a WARNING or Caution notice until you have understood the hazardous conditions and have taken appropriate steps.

Grounding

These are safety class I products and have protective earthing terminals. There must be an uninterruptible safety earth ground from the main power source to the product's input wiring terminals, power cord, or supplied power cord set. Whenever it is likely that the protection has been impaired, disconnect the power cord until the ground has been restored.

For LAN cable grounding:

- If your LAN covers an area served by more than one power distribution system, be sure their safety grounds are securely interconnected.
- LAN cables may occasionally be subject to hazardous transient voltages (such as lightning or disturbances in the electrical utilities power grid). Handle exposed metal components of the network with caution.

Servicing

There are no user-serviceable parts inside these products. Any servicing, adjustment, maintenance, or repair must be performed only by service-trained personnel.

These products do not have a power switch; they are powered on when the power cord is plugged in.

Informations concernant la sécurité



Symbole de référence à la documentation. Si le produit est marqué de ce symbole, reportez-vous à la documentation du produit afin d'obtenir des informations plus détaillées.

WARNING

Dans la documentation, un WARNING indique un danger susceptible d'entraîner des dommages corporels ou la mort.

Caution

Un texte de mise en garde intitulé Caution indique un danger susceptible de causer des dommages à l'équipement.

Ne continuez pas au-delà d'une rubrique WARNING ou Caution avant d'avoir bien compris les conditions présentant un danger et pris les mesures appropriées.

Cet appareil est un produit de classe I et possède une borne de mise à la terre. La source d'alimentation principale doit être munie d'une prise de terre de sécurité installée aux bornes du câblage d'entrée, sur le cordon d'alimentation ou le cordon de raccordement fourni avec le produit. Lorsque cette protection semble avoir été endommagée, débrancher le cordon d'alimentation jusqu'à ce que la mise à la terre ait été réparée.

Mise à la terre du câble de réseau local:

- si votre réseau local s'étend sur une zone desservie par plus d'un système de distribution de puissance, assurez-vous que les prises de terre de sécurité soient convenablement interconnectées.
- Les câbles de réseaux locaux peuvent occasionnellement être soumis à des surtensions transitoires dangereuses (telles que la foudre ou des perturbations dans le réseau d'alimentation public). Manipulez les composants métalliques du réseau avec précautions.

Aucune pièce contenue à l'intérieur de ce produit ne peut être réparée par l'utilisateur. Tout dépannage, réglage, entretien ou réparation devra être confié exclusivement à un personnel qualifié.

Cet appareil ne comporte pas de commutateur principal ; la mise sous tension est effectuée par branchement du cordon d'alimentation.

Hinweise zur Sicherheit



Symbol für Dokumentationsverweis. Wenn das Produkt mit diesem Symbol markiert ist, schlagen Sie bitte in der Produktdokumentation nach, um mehr Informationen über das Produkt zu erhalten.

WARNING

Eine WARNING in der Dokumentation symbolisiert eine Gefahr, die Verletzungen oder sogar Todesfälle verursachen kann.

Caution

Caution in der Dokumentation symbolisiert eine Gefahr, die das Gerät beschädigen kann.

Fahren Sie nach dem Hinweis WARNING oder Caution erst fort, nachdem Sie den Gefahrenzustand verstanden und die entsprechenden Maßnahmen ergriffen haben.

Dies ist ein Gerät der Sicherheitsklasse I und verfügt über einen schützenden Erdungsterminal. Der Betrieb des Geräts erfordert eine ununterbrochene Sicherheitserdung von der Hauptstromquelle zu den Geräteingabeterminals, den Netzkabeln oder dem mit Strom belieferten Netzkabelsatz voraus. Sobald Grund zur Annahme besteht, daß der Schutz beeinträchtigt worden ist, das Netzkabel aus der Wandsteckdose herausziehen, bis die Erdung wiederhergestellt ist.

Für LAN-Kabelerdung:

- Wenn Ihr LAN ein Gebiet umfaßt, das von mehr als einem Stromverteilungssystem beliefert wird, müssen Sie sich vergewissern, daß die Sicherheitserdungen fest untereinander verbunden sind.
- LAN-Kabel können gelegentlich gefährlichen Übergangsspannungen ausgesetzt werden (beispielsweise durch Blitz oder Störungen in dem Starkstromnetz des Elektrizitätswerks). Bei der Handhabung exponierter Metallbestandteile des Netzwerkes Vorsicht walten lassen.

Dieses Gerät enthält innen keine durch den Benutzer zu wartenden Teile. Wartungs-, Anpassungs-, Instandhaltungs- oder Reparaturarbeiten dürfen nur von geschultem Bedienungspersonal durchgeführt werden.

Dieses Gerät hat keinen Netzschalter; es wird beim Anschließen des Netzkabels eingeschaltet.

Considerazioni sulla sicurezza



Simbolo di riferimento alla documentazione. Se il prodotto è contrassegnato da questo simbolo, fare riferimento alla documentazione sul prodotto per ulteriori informazioni su di esso.

WARNING

La dicitura **WARNING**denota un pericolo che può causare lesioni o morte.

Caution

La dicitura **Caution**denota un pericolo che può danneggiare le attrezzature.

Non procedere oltre un avviso di **WARNING** o di **Caution**prima di aver compreso le condizioni di rischio e aver provveduto alle misure del caso.

Questo prodotto è omologato nella classe di sicurezza I ed ha un terminale protettivo di collegamento a terra. Dev'essere installato un collegamento a terra di sicurezza, non interrompibile che vada dalla fonte d'alimentazione principale ai terminali d'entrata, al cavo d'alimentazione oppure al set cavo d'alimentazione fornito con il prodotto. Ogniquilvolta vi sia probabilità di danneggiamento della protezione, disinserite il cavo d'alimentazione fino a quando il collegaento a terra non sia stato ripristinato.

Per la messa a terra dei cavi LAN:

- se la vostra LAN copre un'area servita da più di un sistema di distribuzione elettrica, accertatevi che i collegamenti a terra di sicurezza siano ben collegati fra loro;
- i cavi LAN possono occasionalmente andare soggetti a pericolose tensioni transitorie (ad esempio, provocate da lampi o disturbi nella griglia d'alimentazione della società elettrica); siate cauti nel toccare parti esposte in metallo della rete.

Nessun componente di questo prodotto può essere riparato dall'utente. Qualsiasi lavoro di riparazione, messa a punto, manutenzione o assistenza va effettuato esclusivamente da personale specializzato.

Questo apparato non possiede un commutatore principale; si mette scotto tensione all'inserirsi il cavo d'alimentazione.

Consideraciones sobre seguridad



Símbolo de referencia a la documentación. Si el producto va marcado con este símbolo, consultar la documentación del producto a fin de obtener mayor información sobre el producto.

WARNING

Una WARNING en la documentación señala un riesgo que podría resultar en lesiones o la muerte.

Caution

Una Caution en la documentación señala un riesgo que podría resultar en averías al equipo.

No proseguir después de un símbolo de WARNING o Caution hasta no haber entendido las condiciones peligrosas y haber tomado las medidas apropiadas.

Este aparato se enmarca dentro de la clase I de seguridad y se encuentra protegido por una borna de puesta a tierra. Es preciso que exista una puesta a tierra continua desde la toma de alimentación eléctrica hasta las bornas de los cables de entrada del aparato, el cable de alimentación o el juego de cable de alimentación suministrado. Si existe la probabilidad de que la protección a tierra haya sufrido desperfectos, desenchufar el cable de alimentación hasta haberse subsanado el problema.

Puesta a tierra del cable de la red local (LAN):

- Si la LAN abarca un área cuyo suministro eléctrico proviene de más de una red de distribución de electricidad, cerciorarse de que las puestas a tierra estén conectadas entre sí de modo seguro.
- Es posible que los cables de la LAN se vean sometidos de vez en cuando a voltajes momentáneos que entrañen peligro (rayos o alteraciones en la red de energía eléctrica). Manejar con precaución los componentes de metal de la LAN que estén al descubierto.

Este aparato no contiene pieza alguna susceptible de reparación por parte del usuario. Todas las reparaciones, ajustes o servicio de mantenimiento debe realizarlos solamente el técnico.

Este producto no tiene interruptor de potencia; se activa cuando se enchufa el cable de alimentación.

Safety Information (Japan)

安全性の考慮

安全記号



マニュアル参照記号。製品にこの記号がついている場合はマニュアルを参照し、注意事項等をご確認ください。

WARNING マニュアル中の「WARNING」は人身事故の原因となる危険を示します。

CAUTION マニュアル中の「CAUTION」は装置破損の原因となる危険を示します。

「WARNING」や「CAUTION」の項は飛ばさないで必ずお読みください。危険性に関する記載事項をよく読み、正しい手順に従った上で次の事項に進んでください。

これは安全性クラス1の製品で保護用接地端子を備えています。主電源から製品の入力配線端子、電源コード、または添付の電源コード・セットまでの間、切れ目のない安全接地が存在することが必要です。もしこの保護回路が損なわれたことが推測されるときは、接地が修復されるまで電源コードを外しておいてください。

LAN ケーブルの接地に関して:

- もし貴社の LAN が複数の配電システムにより電力を受けている領域をカバーしている場合には、それらのシステムの安全接地が確実に相互に結合されていることを確認してください。
- LAN ケーブルは時として危険な過度電圧（例えば雷や、配電設備の電力網での障害）にさらされることがあります。露出した金属部分の取扱いには十分な注意をはらってください。

本製品の内部にはユーザーが修理できる部品はありません。サービス、調整、保守および修理はサービス訓練を受けた専門家におまかせください。

本製品には電源スイッチがありません。電源コードを接続したとき電源入となります。

Safety Information (China)

HP 网络产品使用安全手册

使用须知

欢迎使用惠普网络产品，为了您及仪器的安全，请您务必注意如下事项：

1. 仪器要和地线相接，要使用有正确接地插头的电源线，使用中国国家规定的220V电源。
2. 避免高温和尘土多的地方，否则易引起仪器内部部件的损坏。
3. 避免接近高温，避免接近直接热源，如直射太阳光、暖气等其它发热体。
4. 不要有异物或液体落入机内，以免部件短路。
5. 不要将磁体放置于仪器附近。

警告

为防止火灾或触电事故，请不要将该机放置于淋雨或潮湿处。

安装

安装辅助管理模块，请参看安装指南。

保修及技术支持

如果您按照以上步骤操作时遇到了困难，或想了解其它产品性能，请按以下方式与我们联系。

如是硬件故障：

1. 与售出单位或当地维修机构联系。
2. 中国惠普有限公司维修中心地址：
北京市海淀区知春路49号希格玛大厦
联系电话：010-62623888 转 6101
邮政编码：100080

如是软件问题：

1. 惠普用户响应中心热线电话：010-65645959
2. 传真自动回复系统：010-65645735

EMC Regulatory Statements

U.S.A.

FCC Class A

This equipment has been tested and found to comply with the limits for a Class A digital device, pursuant to Part 15 of the FCC Rules. These limits are designed to provide reasonable protection against interference when the equipment is operated in a commercial environment. This equipment generates, uses, and can radiate radio frequency energy and, if not installed and used in accordance with the instruction manual, may cause interference to radio communications. Operation of this equipment in a residential area may cause interference in which case the user will be required to correct the interference at his own expense.

Canada

This product complies with Class A Canadian EMC requirements.

Australia/New Zealand



This product complies with Australia/New Zealand EMC Class A requirements.

Japan

VCCI Class A

この装置は、情報処理装置等電波障害自主規制協議会（VCCI）の基準に基づくクラスA情報技術装置です。この装置を家庭環境で使用すると電波妨害を引き起こすことがあります。この場合には使用者が適切な対策を講ずるよう要求されることがあります。

Korea

사용자 안내문 : A 급기기

이기는 업무용으로 전자파 적합등록을 받은 기기 이오니, 판매자 또는 사용자는 이점을 주의하시기 바라며, 만약 잘못 구입하셨을 때에는 구입한 곳에서 비업무용으로 교환하시기 바랍니다.

Taiwan

警告使用者：這是甲類的資訊產品，在居住的環境中使用時，可能會造成射頻干擾，在這種情況下，使用者會被要求採取某些適當的對策。

European Community

DECLARATION OF CONFORMITY

according to ISO/IEC Guide 22 and EN45014

Manufacturer's Name: Hewlett-Packard Company

Manufacturer's Address: 8000 Foothills Blvd
Roseville, CA 95747-5502
U.S.A.

declares that the product:

Product Name: HP ProCurve Switch 2650,
HP ProCurve Switch 2626

Model Numbers: J4899A, J4899B; J4900A, J4900B

Accessories: J4858A, J4859A, J4860A

Regulatory Model Number: RSVLC-0204

conforms to the following Product Specifications:

Safety: EN60950 (1992) +A1,A2,A3,A4,A11 / IEC 950 (1991) +A1,A2,A3,A4
EN60825-1 (1994) +A11 (1996) / IEC 825-1 (1993), Class 1

EMC: EN 55022 (1998) / CISPR-22 (1997) Class A
EN55024 (1998) / CISPR-24 (1997)
EN 61000-3-2 (2000) / IEC 61000-3-2 (2000) Harmonics
EN 61000-3-3 (1995) / IEC 61000-3-3 (1994) Flicker

Supplementary Information:

The product herewith complies with the requirements of the Low Voltage Directive 73/23/EEC and the EMC Directive 89/336/EEC and carries the CE marking accordingly.

Tested with Hewlett-Packard Co. products only.



Mike Avery,
Regulatory Engineering Manager

Roseville, April 18, 2004

European Contact: Your local Hewlett-Packard Sales and Service Office or Hewlett-Packard GmbH,
Department TRE, Herrenberger Strasse 140, D-71034 Böblingen (FAX: +49-7031-14-3143).

DECLARATION OF CONFORMITY

according to ISO/IEC Guide 22 and EN45014

Manufacturer's Name: Hewlett-Packard Company

Manufacturer's Address: 8000 Foothills Blvd.
Roseville, CA 95747-5502
U.S.A.

declares that the products:

Product Names: HP Procurve Switch 2626 -PWR
HP Procurve Switch 2650 -PWR

Model Numbers: HP J8164A
HP J8165A

Regulatory Model: RSVLC-0302

Accessories: HP J4858A, HP J4859A ,HP J4860A,

Conform to the following Product Specifications:

Safety: EN60950 (2000) / IEC60950 (1999)
EN60825-1: 1994 +A11 (1996) / IEC 825-1 (1993), Class 1

EMC: EN 55022 (1998) / CISPR-22 (1997) Class A
EN 55024 (1998) / CISPR-24 (1997)
EN 61000-3-2 (1995) + A14 / IEC 61000-3-2 (1995) - Harmonics
EN 61000-3-3 (1995)/IEC 61000-3-3 (1994) - Flicker

Supplementary Information:

The product herewith complies with the requirements of the Low Voltage Directive 73/23/EEC and the EMC Directive 89/336/EEC and carries the CE marking accordingly.

Tested with Hewlett-Packard Co. products only.



Mike Avery
Regulatory Engineering Manager

Roseville, 7 October 2003

European Contact: Your local Hewlett-Packard Sales and Service Office or Hewlett-Packard GmbH, Department TRE, Herrenberger Strasse 140, D-71034 Böblingen (FAX:+49-7031-14-3143).

— *This page is intentionally unused.* —

Index

Numerics

- 10/100Base-TX ports
 - location on switch ... 1-3
- 1000Base-LH
 - connections, length limitations ... 2-6
 - ports, cables used with ... 2-6
- 1000Base-LX
 - connections, length limitations ... 2-6
 - ports, cables used with ... 2-6
- 1000Base-SX
 - connections, length limitations ... 2-6
 - ports, cables used with ... 2-6
- 1000Base-T
 - connections, length limitations ... 2-5
 - ports, cables used with ... 2-5

A

- AC power connector
 - location on back of switch ... 1-10
- auto MDI/MDI-X operation ... B-7, B-9
 - HP Auto-MDIX feature ... B-5

B

- back of switch
 - description ... 1-10
 - power connector ... 1-10
- backbone switch
 - topology with ... 2-33, 2-36–2-37

- basic switch configuration
 - IP address ... 3-3
 - manager password ... 3-2
 - subnet mask ... 3-3
 - Switch Setup screen ... 3-2
- basic troubleshooting tips ... 4-1
- blinking LEDs
 - error indications ... 4-4

Bootp

- automatic switch configuration ... 3-2
- for in-band access ... 2-28

buttons

- Clear button ... 1-9
- Reset button ... 1-9

C

cabinet

- mounting the switch in ... 2-11

cables

- 1000Base-LH
 - connections ... 2-6
 - fiber-optic cable specifications ... B-2
 - 1000Base-LX
 - connections ... 2-6
 - fiber-optic cable specifications ... B-2
 - 1000Base-SX
 - connections ... 2-6
 - fiber-optic cable specifications ... B-2
 - 1000Base-T connections ... 2-5
 - connecting cables to switch ports ... 2-18
 - effects of non-standard cables ... 4-2
 - fiber-optic, specifications ... B-2
 - infrastructure requirements ... 2-5
 - length limitations ... 2-5
 - required types ... 2-5
 - serial, for direct console connection ... 2-29
- ### cables, twisted pair
- category 3, 4, 5 ... B-5
 - cross-over cable pin-out ... B-8
 - MDI-X to MDI connections ... B-7, B-9
 - MDI-X to MDI-X connections ... B-8
 - pin-outs ... B-7, B-9
 - straight-through cable pin-out ... B-7, B-9
 - switch-to-computer connection ... B-7, B-9
 - switch-to-switch or hub connection ... B-8
- ### cables, twisted-pair
- HP Auto-MDIX feature ... B-5
 - wiring rules ... B-5
- ### cables, twisted-pair connector pin-outs ... B-5
- cabling infrastructure ... 2-5

- Clear button
 - deleting passwords ... 1-9
 - description ... 1-9
 - location on switch ... 1-3, 1-9
 - restoring factory default configuration ... 1-9, 4-11
 - to delete password protection ... 3-4
- CLI prompt, console
 - displaying ... 2-29
- configuration
 - checking when troubleshooting ... 4-3
 - DHCP/Bootp ... 3-2
 - full duplex only for mini-GBICs ... 2-7
 - IP address ... 3-3
 - IP address, manually ... 3-2
 - manager password ... 3-2
 - restoring factory defaults ... 1-9, 4-11
 - subnet mask ... 3-3
 - Switch Setup screen ... 3-2
- connecting the switch to a power source ... 2-17
- connecting the switch to an EPS ... 2-26–2-27
- connecting the switch to an RPS/EPS ... 2-22, 2-24
- connector specifications ... A-2
- console
 - checking messages during troubleshooting ... 4-9
 - displaying the CLI prompt ... 2-29
 - features ... 2-28
 - how to connect in-band ... 2-28
 - how to connect out-of-band ... 2-28
 - serial cable connection ... 2-29
 - Switch Setup screen ... 3-2
 - Telnet access ... 3-5
 - terminal configuration ... 2-28
- console port
 - definition ... 1-10
 - location on switch ... 1-3
- cross-over cable
 - pin-out ... B-8

D

- deleting passwords ... 1-9
- description
 - back of switch ... 1-10
 - front of switch ... 1-3
 - LEDs ... 1-4
 - switch ... 1-1

- desktop switch
 - sample topology ... 2-30, 2-34
- DHCP
 - automatic switch configuration ... 3-2
 - for in-band access ... 2-28
- diagnostic tests ... 4-9
 - checking the console messages ... 4-9
 - checking the LEDs ... 4-9
 - end-to-end connectivity ... 4-10
 - testing the switch only ... 4-9
 - testing twisted-pair cabling ... 4-10
- downloading new switch software ... 4-12
- dual-personality ports
 - LEDs ... 1-6
 - location on switch ... 1-4
 - operation description ... 1-4

E

- electrical specifications, switch ... A-1
- EMC regulatory statements ... C-8
- environmental specifications, switch ... A-1
- EPS
 - connecting to a switch ... 2-26–2-27

F

- factory default configuration, restoring ... 1-9, 4-11
- Fan Status LED ... 1-5
- Fault LED ... 1-4
 - behavior during self test ... 2-11
 - behaviors ... 1-4
 - blinking definition ... 1-5–1-6, 1-8
 - location on switch ... 1-3
 - showing error conditions ... 4-4
- features
 - console ... 2-28
 - switch ... 1-11
- fiber-optic cables ... B-2
 - 1000Base-LH ... B-2
 - 1000Base-LX ... B-2
 - 1000Base-SX ... B-2

- front of switch ... 1-3
 - 10/100Base-TX ports ... 1-3
 - Clear button ... 1-9
 - description ... 1-3
 - dual-personality ports ... 1-4
 - LEDs ... 1-4
 - network ports ... 1-4
 - Reset button ... 1-9
- full-duplex fixed configuration
 - effects on network connections ... 4-1
- full-duplex operation of mini-GBICs ... 2-7

G

- Gigabit-LH
 - ports, cables used with ... B-2
- Gigabit-SX
 - ports, cables used with ... B-2
- Gigabit-LX
 - ports, cables used with ... B-2

H

- horizontal surface
 - mounting switch on ... 2-17
- HP 600 RPS/EPS
 - cables ... 2-20
 - connectivity ... 2-22
 - LEDs ... 2-20
 - operating characteristics ... 2-19
- HP 610 EPS
 - cables ... 2-25
 - connectivity ... 2-27
 - LEDs ... 2-25
 - operating characteristics ... 2-25
- HP Auto-MDIX
 - feature description ... B-5
- HP ProCurve 600 Redundant and External Power Supply ... 1-2
- HP ProCurve 610 External Power Supply ... 1-2

I

- in-band ... 3-1
- in-band console access
 - types of ... 2-28
- included parts ... 2-1

- installation
 - connecting the switch to a power source ... 2-17
 - horizontal surface mounting ... 2-17
 - location considerations ... 2-6
 - network cable requirements ... 2-5
 - precautions ... 2-4
 - rack or cabinet mounting ... 2-11
 - site preparation ... 2-5
 - wall mounting ... 2-15
- IP address
 - configuring ... 3-3
- IP telephones ... 2-34

L

- LEDs
 - behavior during self test ... 2-10
 - blinking definition ... 1-5–1-6, 1-8
 - checking during troubleshooting ... 4-9
 - descriptions of ... 1-4
 - dual-personality ports ... 1-6
 - error indications ... 4-4
 - Fan Status ... 1-5
 - Fault ... 1-4
 - behavior during self test ... 2-11
 - showing error conditions ... 4-4
 - location on switch ... 1-3
 - on switch ... 1-4
 - port
 - description ... 1-6
 - Power ... 1-4
 - behavior during self test ... 2-11
 - Self Test ... 1-5
 - behavior during self test ... 2-10
 - T and M ... 1-6
- length limitations
 - 1000Base-LH connections ... 2-6
 - 1000Base-LX connections ... 2-6
 - 1000Base-SX connections ... 2-6
 - 1000Base-T connections ... 2-5
- link test ... 4-10
- location for the switch, considerations ... 2-6

M

- MDI-X to MDI network cable ... B-7, B-9
- MDI-X to MDI-X network cable ... B-8

- mini-GBICs
 - full-duplex operation ... 2-7
 - slot, location on switch ... 1-3
- mounting the switch
 - in a rack or cabinet ... 2-11
 - precautions ... 2-4
 - on a horizontal surface ... 2-17
 - on a wall ... 2-15
 - precautions ... 2-15
- Multiple-Display Port LEDs ... 1-7

N

- network cables
 - 1000Base-LH connections ... 2-6
 - 1000Base-LX connections ... 2-6
 - 1000Base-SX connections ... 2-6
 - 1000Base-T connections ... 2-5
 - fiber-optic, specifications ... B-2
 - HP Auto-MDIX feature ... B-5
 - required types ... 2-5
 - twisted-pair connector pin-outs ... B-5
 - twisted-pair, wiring rules ... B-5
- network devices
 - connecting to the switch ... 2-18
- network ports
 - connecting to ... 2-18
 - location on switch ... 1-4
 - standards compliance ... A-2
 - types of ... 1-4, 2-5
- non-standard network cables, effects ... 4-2

O

- out-of-band console access ... 3-5

P

- parts, included with the switch ... 2-1
- password
 - configuring ... 3-2
- passwords
 - deleting with the Clear button ... 3-4
 - if you lose the password ... 3-4
- passwords, deleting ... 1-9
- physical specifications, switch ... A-1
- Ping test ... 4-10

- pin-outs
 - twisted-pair cables ... B-5
- port configuration
 - checking when troubleshooting ... 4-3
- port LEDs
 - description ... 1-6
 - normal operation ... 2-11
 - T and M ... 1-6
- ports
 - 10/100Base-TX, location on switch ... 1-3
 - connecting to ... 2-18
 - console ... 2-28
 - HP Auto-MDIX feature ... B-5
 - network connections ... 2-18
- power connector ... 1-10
- Power LED ... 1-4
 - behavior during self test ... 2-11
 - behaviors ... 1-4
 - location on switch ... 1-3
- power source
 - connecting the switch to ... 2-17
- Power-over-Ethernet
 - PoE ... 2-19
 - PoE power ... 1-2
- precautions
 - mounting the switch ... 2-4
 - power requirements ... 2-4
- preparing the installation site ... 2-5
- Proactive Network tools
 - diagnostics with ... 4-8

R

- rack
 - mounting precautions ... 2-4
 - mounting the switch in ... 2-11
- Redundant and External Power Supply ... 1-2
 - RPS/EPS ... 2-19
- Redundant Power Supply ... 2-19
- regulatory statements ... C-8
- Reset button
 - description ... 1-9
 - location on switch ... 1-3, 1-9
 - restoring factory default configuration ... 4-11

- resetting the switch
 - factory default reset ... 4-11
 - location of Reset button ... 1-9
 - troubleshooting procedure ... 4-9
- RPS/EPS ... 2-19
 - cables ... 2-20
 - connecting to a switch ... 2-22, 2-24
 - operation ... 2-19

S

- safety and regulatory statements ... C-1
- safety specifications ... A-2
- segment switch
 - sample topology ... 2-31, 2-35
- self test
 - Fault LED behavior ... 2-11
 - LED behavior during ... 2-10
 - Power LED behavior ... 2-11
- Self Test LED ... 1-5
 - behavior during factory default reset ... 4-11
 - behavior during self test ... 2-10
- serial cable
 - for direct console connection ... 2-29
- slots for mini-GBICs
 - location on switch ... 1-3
- specifications
 - connectors ... A-2
 - electrical ... A-1
 - environmental ... A-1
 - physical ... A-1
 - safety ... A-2
- straight-through cable
 - pin-out ... B-7, B-9
- subnet mask
 - configuring ... 3-3
- summary
 - of cables used with the switch ... 2-5

- switch
 - connecting to a power source ... 2-17
 - description ... 1-1
 - downloading new software ... 4-12
 - electrical specifications ... A-1
 - environmental specifications ... A-1
 - features ... 1-11
 - front panel description ... 1-3
 - included parts ... 2-1
 - LED descriptions ... 1-4
 - mounting in a rack or cabinet ... 2-11
 - mounting on a wall ... 2-15
 - mounting on horizontal surface ... 2-17
 - physical specifications ... A-1
- switch operation
 - verifying after installation ... 2-9
- Switch Setup screen ... 3-2
 - configuring a subnet mask ... 3-3
 - configuring an IP address ... 3-3
 - field descriptions ... 3-3

T

- Telnet access to the console ... 3-5
- terminal configuration ... 2-28
- testing
 - checking the console messages ... 4-9
 - checking the LEDs ... 4-9
 - diagnostic tests ... 4-9
 - end-to-end communications ... 4-10
 - link test ... 4-10
 - Ping test ... 4-10
 - switch operation ... 4-9
 - switch-to-device communications ... 4-10
 - twisted-pair cabling ... 4-10
- tips for troubleshooting ... 4-1
- topologies
 - effects of improper topology ... 4-2
 - samples of ... 2-30, 2-34

- troubleshooting ... 4-1
 - basic tips ... 4-1
 - checking port configuration ... 4-3
 - checking the console messages ... 4-9
 - checking the LEDs ... 4-9
 - common network problems ... 4-1
 - connecting to fixed full-duplex devices ... 4-1
 - diagnostic tests ... 4-9
 - effects of improper topology ... 4-2
 - effects of non-standard cables ... 4-2
 - link test ... 4-10
 - Ping test ... 4-10
 - Proactive Network tools ... 4-8
 - restoring factory default configuration ... 4-11
 - testing connections to other devices ... 4-10
 - testing end-to-end communications ... 4-10
 - testing the switch ... 4-9
 - testing the twisted-pair cables ... 4-10
- twisted-pair cable
 - cross-over cable pin-out ... B-8
 - pin-outs ... B-5, B-7, B-9
 - straight-through cable pin-out ... B-7, B-9
 - switch-to-computer connection ... B-7, B-9
 - switch-to-switch or hub connection ... B-8
 - testing ... 4-10
- twisted-pair ports
 - HP Auto-MDIX feature ... B-5

V

- VT-100 terminal
 - serial cable connection for ... 2-29

W

- wall
 - mounting switch on ... 2-15
- wireless access point
 - WAP ... 2-34
- wiring rules for twisted-pair cables ... B-5



Technical information in this document
is subject to change without notice.

©Copyright 2001, 2004
Hewlett-Packard Development Company, L.P.
Reproduction, adaptation, or translation
without prior written permission is prohibited
except as allowed under the copyright laws.

Printed in Taiwan
September 2004

Manual Part Number
5990-8821

