

installation and  
getting started guide



hp procurve  
600 redundant and external  
power supply

[www.hp.com/go/hpprocurve](http://www.hp.com/go/hpprocurve)



Power over Ethernet Devices



---

HP ProCurve 600  
Redundant and External  
Power Supply

---

Installation and Getting Started Guide

© Copyright 2003 Hewlett-Packard Development Company, L.P. The information contained herein is subject to change without notice.

This document contains proprietary information, which is protected by copyright. No part of this document may be photocopied, reproduced, or translated into another language without the prior written consent of Hewlett-Packard.

### **Publication Number**

5990-6035  
December 2003  
Edition 1

### **Applicable Products**

HP ProCurve 600 Redundant and  
External Power Supply (J8168A)

### **Disclaimer**

HEWLETT-PACKARD COMPANY MAKES NO WARRANTY OF ANY KIND WITH REGARD TO THIS MATERIAL, INCLUDING, BUT NOT LIMITED TO, THE IMPLIED WARRANTIES OF MERCHANTABILITY AND FITNESS FOR A PARTICULAR PURPOSE. Hewlett-Packard shall not be liable for errors contained herein or for incidental or consequential damages in connection with the furnishing, performance, or use of this material.

The only warranties for HP products and services are set forth in the express warranty statements accompanying such products and services. Nothing herein should be construed as constituting an additional warranty. HP shall not be liable for technical or editorial errors or omissions contained herein.

Hewlett-Packard assumes no responsibility for the use or reliability of its software on equipment that is not furnished by Hewlett-Packard.

### **Warranty**

See the Customer Support/Warranty booklet included with the product.

A copy of the specific warranty terms applicable to your Hewlett-Packard products and replacement parts can be obtained from your HP Sales and Service Office or authorized dealer.

---

### **Safety**

Before installing and operating these products, please read the "Installation Precautions" in chapter 2, "Installing and Connecting the HP 600 RPS/EPS", and the safety statements in appendix C, "Safety and Regulatory Statements".

---

---

# Contents

## **1 Introducing the HP ProCurve 600 Redundant and External Power Supply**

<b>Back of the Unit</b> .....	1-2
RPS Ports .....	1-2
EPS Ports .....	1-2
Power Connector .....	1-2
Port Status LEDs .....	1-2
<b>Front of the Unit</b> .....	1-3
LEDs .....	1-3
RPS Port Operation .....	1-4
EPS Port Operation .....	1-4
<b>Supported Switches</b> .....	1-5

## **2 Installing and Connecting the HP 600 RPS/EPS**

<b>Included Parts</b> .....	2-1
<b>Installation Procedures</b> .....	2-2
Summary .....	2-2
Installation Precautions: .....	2-3
1. Prepare the Installation Site .....	2-4
2. Mount the HP 600 RPS/EPS .....	2-5
Rack or Cabinet Mounting .....	2-5
Horizontal Surface Mounting .....	2-7
3. Connect to Switches .....	2-8
Connecting RPS Ports to Switches .....	2-8
Connecting EPS Ports to Switches .....	2-9
4. Connect to AC Power .....	2-10
5. Verify Correct HP 600 RPS/EPS Operation .....	2-11
LED Behavior: .....	2-11

<b>Recommended Connection Topologies</b> .....	2-12
EPS Connections .....	2-12
Recommendations .....	2-12
Limitations .....	2-12
RPS Connections .....	2-13
Recommendations .....	2-13
Limitations .....	2-13
Status Indication .....	2-14
UPS Support .....	2-14

### **3 Troubleshooting**

<b>Basic Troubleshooting Tips</b> .....	3-1
<b>Diagnosing with the LEDs</b> .....	3-2
<b>Diagnostic Tests</b> .....	3-5
Testing the HP 600 RPS/EPS by Resetting It .....	3-5
Checking the Unit's LEDs .....	3-5
Testing Cabling .....	3-5
<b>HP Customer Support Services</b> .....	3-6

### **A Specifications**

Physical .....	A-1
Electrical .....	A-1
Environmental .....	A-1
Acoustic .....	A-2
Connectors .....	A-2
Safety .....	A-2
EMC Compliance (Class A) .....	A-2
Immunity .....	A-2

### **B Connectors and Cables**

HP 600 RPS/EPS Ports .....	B-1
<b>HP 600 RPS/EPS Connector Pin-Outs</b> .....	B-2
EPS Cable for HP PoE Switch Connections .....	B-2
Connector Diagram .....	B-2
Pin Assignments .....	B-2

RPS Cable for HP ProCurve Switch Connections .....	B-3
Connector Diagram .....	B-3
Pin Assignments .....	B-3

## **C Safety and EMC Regulatory Statements**

<b>Safety Information</b> .....	C-1
<b>EMC Regulatory Statements</b> .....	C-8

## **Index**

— *This page is intentionally unused.* —

# Introducing the HP ProCurve 600 Redundant and External Power Supply

The HP ProCurve 600 Redundant and External Power Supply is a dual-mode power supply that can supply backup power to so equipped HP ProCurve switches and additional power for Power over Ethernet (PoE) capable switches.

## HP ProCurve 600 Redundant and External Power Supply (J8168A)



Throughout this manual, this unit will be abbreviated as the HP 600 RPS/EPS.

The HP 600 RPS/EPS has six Redundant Power Supply (RPS) ports for supporting backup power to six supported HP ProCurve switches. The HP 600 RPS/EPS also has two External Power Supply (EPS) ports that provide PoE power for up to two HP PoE switches.

This chapter describes your HP 600 RPS/EPS including:

- Front and back of the unit
- RPS/EPS features

## Back of the Unit

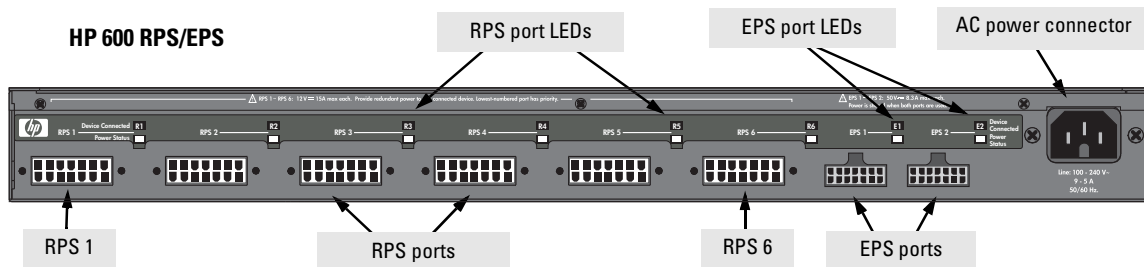

### RPS Ports

The HP 600 RPS/EPS has six redundant power supply ports. You can connect up to six HP ProCurve switch units, but backup power can be supplied to only one unit based on port priority. Port 1 has the highest priority and port 6 the lowest.

### EPS Ports

The HP 600 RPS/EPS has two external power supply ports. You can connect one or two HP PoE capable switches to provide PoE power as a primary or backup source. Power is equally shared between the two EPS ports; one port supplies maximum power if the other port is not used.

### Power Connector

The HP 600 RPS/EPS does not have a power switch; it is powered on when connected to an active AC power source. The unit automatically adjusts to any voltage between 100–240 volts and either 50 or 60 Hz. There are no voltage range settings required.

### Port Status LEDs

The RPS and EPS port status LEDs on the unit's back panel are a duplication of those on the front panel. For a description of these LEDs, see Table 1-1 on page 1-3.

## Front of the Unit

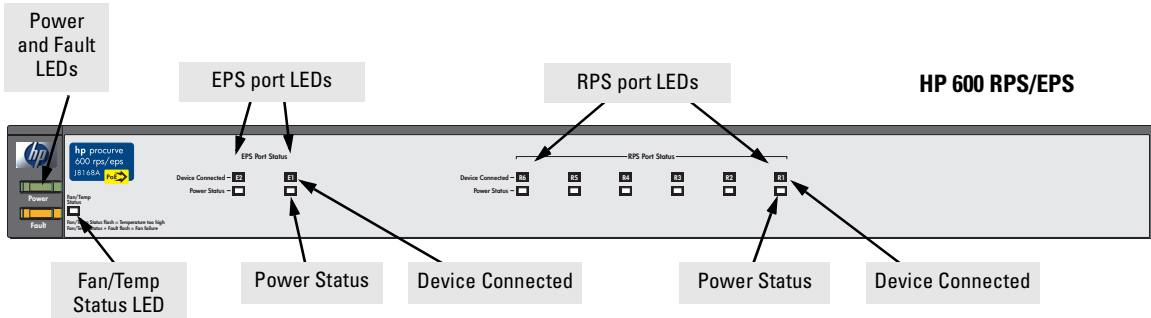

## LEDs

**Table 1-1. HP 600 RPS/UPS LEDs**

LED	State	Meaning
Power (green)	On	The unit is receiving power.
	Off	The unit is NOT receiving power.
Fault (orange)	Off	The normal state; indicates that there are no fault conditions on the unit.
	Blinking*	A fault has occurred on the unit, one of the ports, or the fan. The Status LED for the component with the fault will blink simultaneously.
	On	On briefly after the unit is powered on or reset, at the beginning of unit self test. If this LED is on for a prolonged time, the unit has encountered a fatal hardware failure, or has failed its self test. See chapter 4, "Troubleshooting" for more information.
Fan/Temp Status (green)	On	The cooling fans are operating normally.
	Blinking*	One of these conditions exists: <ul style="list-style-type: none"> <li>• A cooling fan has failed. The unit Fault LED will be blinking simultaneously.</li> <li>• There is an over temperature condition in the unit. The unit Fault LED is off.</li> </ul>
Port Status (on front and back panels)		
Device Connected (green – over-laid with the port number)	On	There is a valid connection to a device. For xl PoE Modules, the EPS Device Connected LED is only on if the module is receiving power from the 5300 switch chassis.
	Off	There is no device connected to the port.
<b>* The blinking behavior is an on/off cycle once every 1.6 seconds, approximately.</b>		

**Table 1-1. HP 600 RPS/EPS LEDs (Continued)**

LED	State	Meaning
Power Status (green)	On	The unit is supplying power to a connected device.
	Off	One of these conditions exists: <ul style="list-style-type: none"> <li>• There is no connected device.</li> <li>• A connected RPS device does not require power.</li> <li>• A connected EPS device has not successfully communicated for EPS power.</li> </ul>
	Blinking*	One of these conditions exists: <ul style="list-style-type: none"> <li>• RPS power is not available to the connected device because a higher priority port is using it.</li> <li>• When the LED is blinking simultaneously with the Fault LED, there is a fault condition on the port.</li> </ul>
* The blinking behavior is an on/off cycle once every 1.6 seconds, approximately.		

## RPS Port Operation

The HP 600 RPS/EPS can be connected to six switches through RPS cables, but can provide redundant power to only one switch whose AC power fails. The unit can provide up to 180 W of power at +12 VDC to a single switch.

Each RPS port has a priority, with port 1 the highest and port 6 the lowest. The HP 600 RPS/EPS always provides power to a switch connected to a higher priority port, if necessary by dropping power to a switch on a lower priority port. The switching of power from low-priority ports to high-priority ports is completely automatic and effectively instantaneous.

The HP 600 RPS/EPS is able to detect switches connected to each RPS port and also the status of their primary AC power supply. The unit supports a hot-plug feature where switches can be connected or disconnected to the RPS ports without causing any disruption either to switch operation or the HP 600 RPS/EPS. Over-current protection on each RPS port prevents any switch from exceeding the power supply limit of the unit. Any overload condition causes the HP 600 RPS/EPS to shut down the port.

## EPS Port Operation

The HP 600 RPS/EPS supports two EPS ports that can provide power to PoE capable switches through EPS cables. The HP 600 RPS/EPS can provide PoE power to a switch as a primary source or as a backup to a switch that has its own internal PoE power supply.

The HP 600 RPS/EPS can provide up to 368 W of PoE power at -50 VDC. There are four possible power allocations:

- All 368 W of power allocated to port 1 and none to port 2
- All 368 W of power allocated to port 2 and none to port 1
- Port 1 and port 2 each allocated 184 W
- No power allocated to either port

If power is shared between the two EPS ports, current limits are set to prevent an over-current condition. An over-current condition causes the port power to be shut down. Also, EPS power may be lost if a connected device has not successfully communicated for EPS power. Lastly, if the EPS power supply fails, EPS power is lost. Try disconnecting, then reconnecting the EPS cable to restore EPS power. See “Recommended Connection Topologies” on page 2-12.

---

## Supported Switches

Switch	HP Product Number
HP ProCurve Switch 2824	J4903A
HP ProCurve Switch 2848	J4904A
HP ProCurve Switch 2626-PWR	J8164A
HP ProCurve Switch 2650-PWR	J8165A
HP ProCurve Switch xl PoE Module	J8161A

— *This page is intentionally unused.* —

# Installing and Connecting the HP 600 RPS/EPS

---

The HP 600 RPS/EPS is easy to install. It comes with an accessory kit that includes the brackets for mounting the unit in a standard 19-inch telco rack or in an equipment cabinet, and rubber feet that can be attached so the unit can be securely located on a horizontal surface. The brackets are designed to allow mounting the unit in a variety of locations and orientations.

This chapter shows you how to install your HP 600 RPS/EPS.

---

## Included Parts

The HP 600 RPS/EPS has the following components shipped with it:

- *HP ProCurve EPS/RPS Installation and Getting Started Guide* (5990-6035), this manual
- *HP ProCurve PoE Planning and Implementation Guide* (5990-6045)
- Read Me First (5990-6034)
- Customer Support/Warranty booklet (5990-6019)
- Accessory kit (5069-6535)
  - two mounting brackets
  - eight 8-mm M4 screws to attach the mounting brackets to the unit
  - four 5/8-inch number 12-24 screws to attach the unit to a rack
  - four rubber feet
- Six RPS cables
- Two EPS cables
- AC power cord, one of the following:

United States/Canada/Mexico	8120-5337
Continental Europe	8120-5336
United Kingdom/Hong Kong/Singapore	8120-5334
Australia/New Zealand	8120-5335
Japan	8120-5342
China	8120-8385
Denmark	8120-5340
Switzerland	8120-5339

# Installation Procedures

## Summary

Follow these easy steps to install your HP 600 RPS/EPS. The rest of this chapter provides details on these steps.

1. **Prepare the installation site (page 2-4).** Make sure that the physical environment into which you will be installing the unit is properly prepared, including having the correct cabling ready to connect to the unit and having an appropriate location for the unit. *Please see page 2-3 for some installation precautions.*
2. **Mount the unit (page 2-5).** The HP 600 RPS/EPS can be mounted in a 19-inch telco rack, in an equipment cabinet, or on a horizontal surface.
3. **Connect devices to the unit (page 2-8).** Using the supplied RPS and EPS cables, connect the unit to the devices that it will support with redundant power or PoE power.
4. **Connect power to the unit (page 2-10).** Once the HP 600 RPS/EPS is mounted, plug it into a nearby main power source.
5. **Verify that the unit is operating correctly (page 2-11).** This is a simple process of observing that the LEDs on the unit's front panel indicate correct operation.

At this point, your HP 600 RPS/EPS is fully installed. See the rest of this chapter if you need more detailed information on any of these installation steps.

## Installation Precautions:

Follow these precautions when installing your HP ProCurve EPS/RPS:

---

### Warning

- The rack or cabinet should be adequately secured to prevent it from becoming unstable and/or falling over.

Devices installed in a rack or cabinet should be mounted as low as possible, with the heaviest devices at the bottom and progressively lighter devices installed above.

---

### Cautions

- Make sure that the power source circuits are properly grounded, then use the power cord supplied with the unit to connect it to the power source.
- If your installation requires a different power cord than the one supplied with the unit, be sure to use a power cord displaying the mark of the safety agency that defines the regulations for power cords in your country. The mark is your assurance that the power cord can be used safely with the unit.
- When installing the HP 600 RPS/EPS, note that the AC outlet should be near the unit and should be easily accessible in case the unit must be powered off.
- Ensure that the HP 600 RPS/EPS does not overload the power circuits, wiring, and over-current protection. To determine the possibility of overloading the supply circuits, add together the ampere ratings of all devices installed on the same circuit as the HP 600 RPS/EPS and compare the total with the rating limit for the circuit. The maximum ampere ratings are usually printed on devices near the AC power connectors.
- Do not install the unit in an environment where the operating ambient temperature might exceed 55°C (131°F).
- Make sure the air flow around the sides and back of the unit is not restricted. If this unit is placed in a fully enclosed rack, make certain that the ambient temperature inside the rack near the unit does not exceed 55°C (131°F).

## 1. Prepare the Installation Site

- **Cabling** - Only use the RPS and EPS cables supplied with the HP 600 RPS/ EPS to connect to switches.
  
- **Installation Location** - Before installing the HP 600 RPS/ EPS, plan its location and orientation relative to other devices and equipment:
  - In the back of the unit, leave at least 7.6 cm (3 inches) of space for the EPS and RPS cables, and the power cord.
  - On the sides of the unit, leave at least 7.6 cm (3 inches) for cooling.

## 2. Mount the HP 600 RPS/EPS

The HP 600 RPS/EPS can be mounted in these ways:

- in a rack or cabinet
- on a horizontal surface

### Rack or Cabinet Mounting

The HP 600 RPS/EPS is designed to be mounted in any EIA-standard 19-inch telco rack or communication equipment cabinet. Note that the mounting brackets have multiple mounting holes and can be rotated allowing for a wide variety of mounting options.

---

**Warning**

---

*For safe operation, please read the mounting precautions on page 2-3, before mounting the unit.*

---

**Equipment  
Cabinet  
Note**

---

The 12-24 screws supplied with the unit are the correct threading for standard EIA/TIA open 19-inch racks. If you are installing the unit in an equipment cabinet such as a server cabinet, use the clips and screws that came with the cabinet in place of the 12-24 screws that are supplied with the unit.

1. Use a #1 Phillips (cross-head) screwdriver and attach the mounting brackets to the unit with the included 8-mm M4 screws.

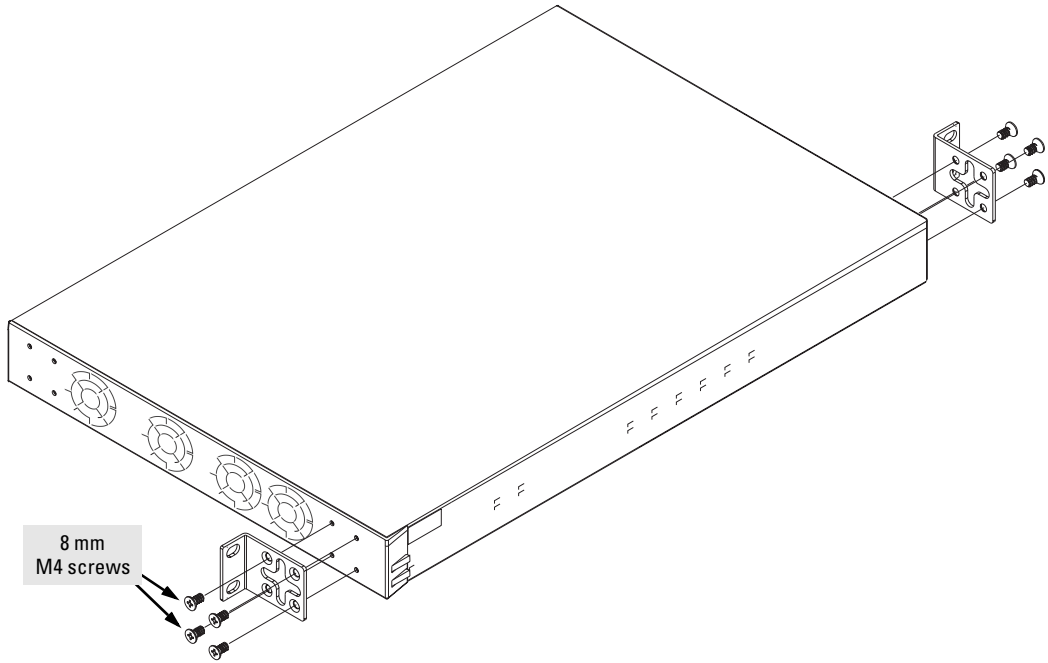

---

**Warning**

---

**For safe reliable installation, only use the screws provided in the accessory kit to attach the mounting brackets to the unit.**

---

**Note**

---

Note that the mounting brackets have multiple mounting holes and can be rotated allowing for a wide variety of mounting options. These include mounting the unit so that its front face is flush with the face of the rack, or mounting it in a more balanced position as shown in the illustration above.

2. Hold the unit with attached brackets up to the rack and move it vertically until rack holes line up with the bracket holes, then insert and tighten the four number 12-24 screws holding the brackets to the rack.

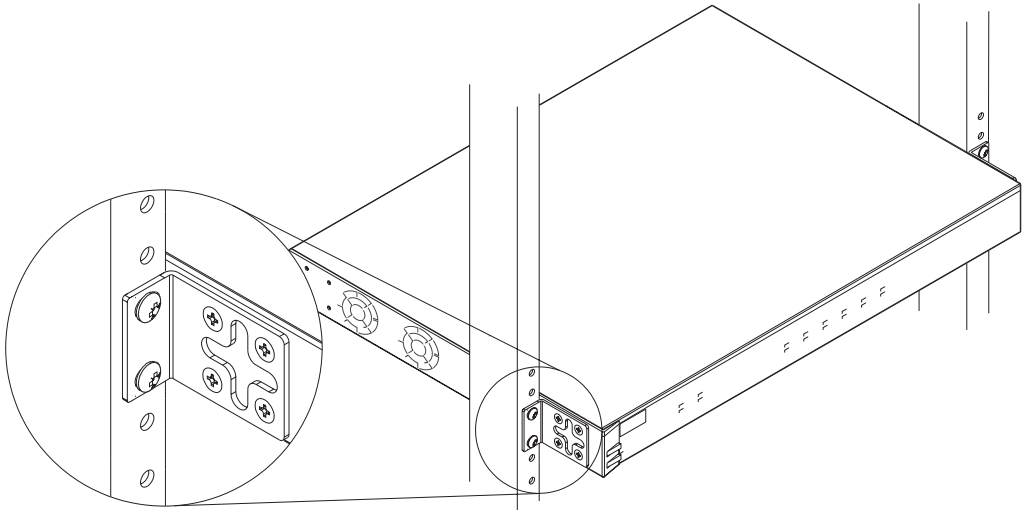

## Horizontal Surface Mounting

Place the unit on a table or other horizontal surface. The HP 600 RPS/EPS comes with rubber feet in the accessory kit that can be used to help keep the unit from sliding on the surface.

Attach the rubber feet to the four corners on the bottom of the unit within the embossed angled lines. Use a sturdy surface in an uncluttered area. You may want to secure the EPS and RPS cables and the unit's power cord to the table leg or other part of the surface structure to help prevent tripping over the cords.

---

### **Caution**

---

Make sure the air flow is not restricted around the sides and back of the unit.

### 3. Connect to Switches

Connect the EPS and RPS cables from the supported network switches to the appropriate ports on the HP 600 RPS/EPS.

#### Connecting RPS Ports to Switches

**To connect:**

Push the RPS cable plug into the desired RPS port until the thumb screws engage with the screw holes in the unit. Tighten the plug thumb screws to secure the connection.

When power is on for the HP 600 RPS/ EPS and for the connected switch, the Device Connected LED should go on to confirm a powered-on switch is at the other end of the cable.

If the Device Connected LED does *not* go on when the RPS cable is connected to the port, see “Diagnosing with the LEDs” in chapter 3, “Troubleshooting”.

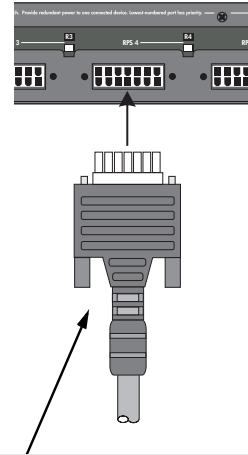

- RPS Cable:
- Only use the cables supplied with the unit
  - The cable connectors are keyed and can only be attached in one orientation

---

#### Note

---

Connect switches to the RPS ports based on their priority, with the highest priority switch connected to port 1.

**To disconnect:**

Unscrew the thumb screws on the plug and pull the plug out of the port.

## Connecting EPS Ports to Switches

### To connect:

Push the EPS cable plug into the EPS port until the tab on the plug clicks into place. When power is on for the HP 600 RPS/EPS and for the connected device, the Device Connected LED should go on to confirm a powered-on switch is at the other end of the cable.

If the Device Connected LED does *not* go on when the EPS cable is connected to the port, see “Diagnosing with the LEDs” in chapter 3, “Troubleshooting”.

### To disconnect:

Press the small tab on the plug and pull the plug out of the port.

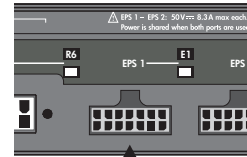

#### EPS Cable:

- Only use the cables supplied with the unit
- The cable connectors are keyed and can only be attached in one orientation

## 4. Connect to AC Power

Connect the power cord supplied with the HP 600 RPS/EPS to the power connector on the back of the unit, and then into a properly grounded electrical outlet.

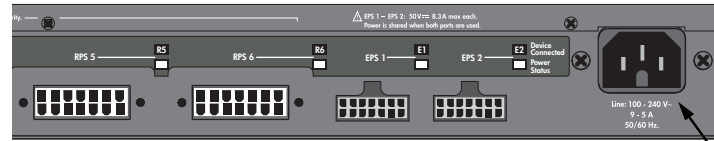

Connect the AC power cord to the power connector

---

### Note

The HP 600 RPS/EPS does not have a power switch. It is powered on when the power cord is connected to the unit and to a power source. For safety, the power outlet should be located near the unit installation.

The unit automatically adjusts to any voltage between 100-240 volts and either 50 or 60 Hz. There are no voltage range settings required.

If your installation requires a different power cord than the one supplied with the unit, be sure the cord is adequately sized for the unit's current requirements. In addition, be sure to use a power cord displaying the mark of the safety agency that defines the regulations for power cords in your country. The mark is your assurance that the power cord can be used safely with the unit.

---

## 5. Verify Correct HP 600 RPS/EPS Operation

When the HP 600 RPS/EPS is mounted in its location and powered on, you should first verify that it is working properly by checking the unit's LEDs.

Check the LEDs on the unit as described below.

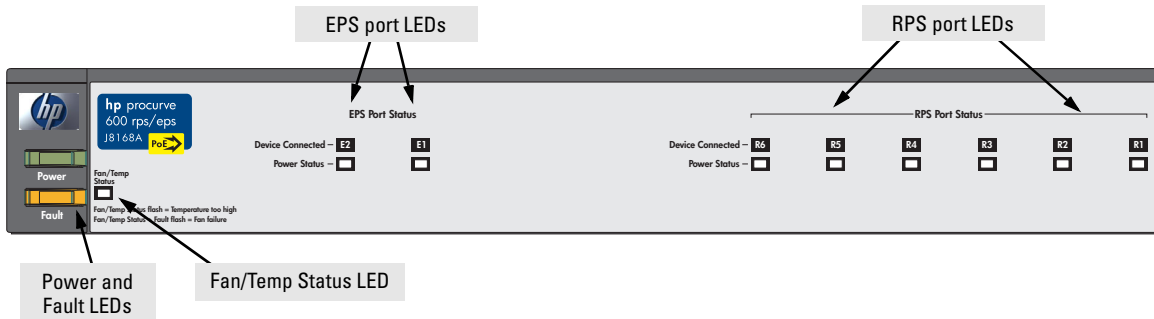

When the unit is powered on, it performs its diagnostic self test. Self test takes approximately 5 seconds to complete.

### LED Behavior:

#### During the self test:

- Initially, all the unit and port LEDs are on and stay on for most of the duration of the self test.
- Most of the LEDs go off and then may come on again during phases of the self test.

#### When the self test completes successfully:

- The **Power** and **Fan/Temp Status** LEDs remain on.
- The **Fault** LED goes off.
- The EPS and RPS Port Status LEDs on the front of the unit go into their normal operational mode:
  - If the ports are connected to active devices, the **Device Connected** LEDs should be on.
  - If the ports are not connected to active devices, the LEDs stay off.

If the LED display is different than what is described above, especially if the **Fault** LED stays on for more than 15 seconds or it starts blinking, the self test has not completed correctly. Refer to chapter 4, “Troubleshooting” for diagnostic help.

## Recommended Connection Topologies

This section shows you some recommended connection topologies using the HP 600 RPS/EPS. For more topology information, see the HP network products World Wide Web site, <http://www.hp.com/go/hpprocurve>.

### EPS Connections

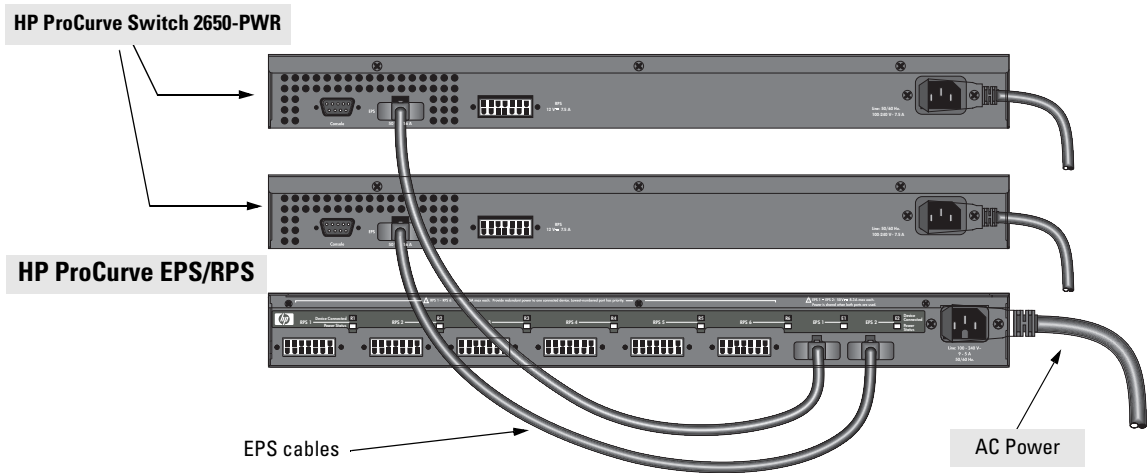

### Recommendations

The HP 600 RPS/EPS is designed to provide primary or backup power to up to two HP PoE switches. In the illustration above, two HP ProCurve Switch 2650-PWR units are being supplied with external PoE power from an HP 600 RPS/EPS. The switches provide PoE power to Ethernet devices connected to their ports.

### Limitations

In the illustration above, the two switches connected to the HP 600 RPS/EPS are limited to 184 W of power on each EPS port. If a switch tries to draw more than 184 W of power from the HP 600 RPS/EPS, an over-current condition occurs and the EPS port shuts down. To supply more than 184 W on one EPS port, the other port must first be disconnected. The maximum power that can be provided when only one EPS port is connected to a switch is 368 W.

## RPS Connections

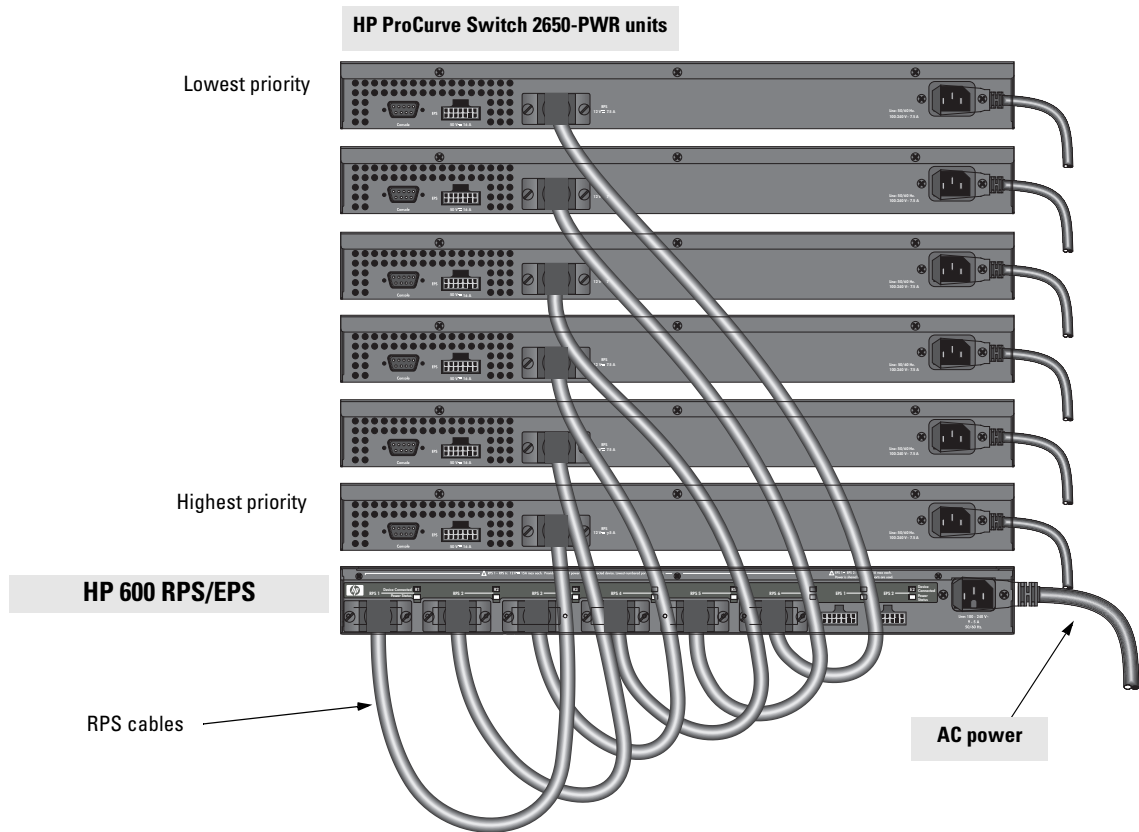

### Recommendations

The HP 600 RPS/EPS can provide backup power support for up to six HP ProCurve switches. In the illustration above, six HP ProCurve Switch 2650-PWR units are connected to the RPS ports on an HP 600 RPS/EPS.

### Limitations

The HP 600 RPS/EPS can supply power to only one connected and failed switch at a time. In the illustration above, the switch connected to RPS port 1 has the highest priority and the switch connected to RPS port 6 has the lowest priority. When multiple switches fail, a switch connected to a higher priority port always receives power before a switch connected to a lower priority port.

## Status Indication

The Power Status LEDs on the HP 600 RPS/EPS indicate if a port can provide power. For example, if six switches are connected to the HP 600 RPS/EPS and the power to the switch on port 4 fails, the Power Status LED for port 4 turns on and for ports 5 and 6 it blinks. The Power Status LEDs for ports 1, 2, and 3 remain off. The blinking Power Status LEDs for ports 5 and 6 indicate that they are lower priority ports and cannot supply power to the connected switches.

## UPS Support

The HP 600 RPS/EPS may be used in configurations where an Uninterruptible Power Supply (UPS) is desired. See Appendix A, “Specifications”, for the power requirements of the HP 600 RPS/EPS for use in determining your UPS requirements.

# Troubleshooting

---

This chapter describes how to troubleshoot your HP 600 RPS/EPS.

This chapter describes the following:

- basic troubleshooting tips (page 3-1)
  - diagnosing with the LEDs (page 3-2)
  - diagnostic tests (page 3-5)
  - HP Customer Support Services (page 3-6)
- 

## Basic Troubleshooting Tips

Most problems are caused by the following situations. Check for these items first when starting your troubleshooting:

- **Faulty or loose cables.** Look for loose or obviously faulty connections. If the cables appear to be OK, make sure the connections are secure. If that does not correct the problem, try a different cable.
- **Connection topologies.** It is important to make sure you have a valid connection topology. The HP 600 RPS/EPS can support two HP PoE devices on its EPS ports, but with limited power output. Up to six HP ProCurve switches can be connected to the RPS ports, but only one can be supplied power based on port priority. Sample topologies are shown at the end of chapter 2 in this book.
- **Power limitations.** Be sure to understand the power limitations of the HP 600 RPS/EPS when connecting switches. An overload condition on a port causes the port to be shut down.

---

### Note

Use caution when power cycling the HP 600 RPS/EPS as this may affect switches receiving operating power from the unit.

---

## Diagnosing with the LEDs

Table 3-1 shows LED patterns on the HP 600 RPS/EPS that indicate problem conditions.

1. Check in the table for the LED pattern that you see on your HP 600 RPS/EPS.
2. Refer to the corresponding diagnostic tip on the next few pages.

**Table 3-1. LED Error Indicators**

LED Pattern Indicating Problems					Diagnostic Tips
Power	Fault	Fan/Temp Status	Device Connected	Power Status	
Off with power cord plugged in	*	*	*	*	❶
On	Prolonged On	*	*	*	❷
On	Blinking <sup>†</sup>	*	*	*	❸
On	Blinking <sup>†</sup>	Blinking <sup>†</sup>	*	*	❹
On	Off	Blinking <sup>††</sup>	*	*	❺
On	Blinking <sup>†</sup>	*	*	Blinking <sup>†</sup>	❻
On	Off	*	*	Blinking <sup>†</sup>	❼
On	Off	*	Off with cable connected	Off	❽
On	Off	*	On with cable connected	Off <sup>††</sup> (EPS port only)	❾

\* This LED is not important for the diagnosis.  
<sup>†</sup> The blinking behavior is an on/off cycle once every 1.6 seconds, approximately.  
<sup>††</sup> Check the log file of the connected switch for a message on the fault.

## Diagnostic Tips:

Tip	Problem	Solution
<b>1</b>	The unit is not plugged into an active AC power source, or the unit's power supply may have failed.	<ol style="list-style-type: none"> <li>1. Verify that the power cord is plugged into an active power source and to the unit. Make sure these connections are snug.</li> <li>2. Try power cycling the unit by unplugging and plugging the power cord back in.</li> <li>3. If the Power LED is still not on, verify that the AC power source works by plugging another device into the outlet. Or try plugging the unit into a different outlet or try a different power cord.</li> </ol> <p>If the power source and power cord are OK and this condition persists, the unit's power supply may have failed. Call your HP-authorized LAN dealer, or use the electronic support services from HP to get assistance. See the Customer Support/Warranty booklet for more information.</p>
<b>2</b>	A hardware failure has occurred. All the LEDs will stay on indefinitely.	Try power cycling the unit. If the fault indication reoccurs, the unit may have failed. Call your HP-authorized LAN dealer, or use the electronic support services from HP to get assistance. See the Customer Support/Warranty booklet for more information.
<b>3</b>	The unit has experienced a failure.	Try resetting the unit by power cycling the unit. If necessary to resolve the problem, contact your HP-authorized LAN dealer, or use the electronic support services from HP to get assistance. See the Customer Support/Warranty booklet for more information.
<b>4</b>	One or more of the unit cooling fans may have failed.	Try disconnecting power from the unit and waiting a few moments. Then reconnect the power to the unit and check the LEDs again. If the error indication reoccurs, one or more of the fans has failed. The unit has four fans and may continue to operate under this condition if the ambient temperature does not exceed normal room temperature, but for best operation, the unit should be replaced. Contact your HP-authorized LAN dealer, or use the electronic support services from HP to get assistance. See the Customer Support/Warranty booklet for more information.
<b>5</b>	There is an over temperature condition in the unit.	Check the log file of the connected switch for more detailed information. Make sure the air flow around the sides and back of the unit is not restricted. Also check to see that no hot exhaust air from another device is blowing on the unit. If this unit is in a fully enclosed rack, make certain that the ambient temperature inside the rack near the unit does not exceed 55°C (131°F).
<b>6</b>	The port for which the LED is blinking has experienced a failure.	An over-current condition may have been caused by a connected device. Unplug the cable connected to the port, then plug it back in. If the condition returns, carefully power cycle the unit (be careful that other devices connected to the HP 600 RPS/EPS will not be adversely affected). If the fault indication reoccurs, the unit port may have failed. Call your HP-authorized LAN dealer, or use the electronic support services from HP to get assistance. See the Customer Support/Warranty booklet for more information.
<b>7</b>	RPS power is not available to the connected device.	A higher priority RPS port is using RPS power from the HP 600 RPS/EPS. The LED blinks even if the connected device does not require RPS power at this time. The blinking LED is indicating that there is no RPS power available to that device should it be required. Higher priority ports will get RPS power if it is needed, so their Power Status LED remains off. The highest priority device should be connected to RPS port 1 to ensure that it receives power if it is needed.

**Troubleshooting**  
Diagnosing with the LEDs

Tip	Problem	Solution
⑧	The connection is not working properly.	Try the following procedures: <ul style="list-style-type: none"><li>• For the indicated port, verify that both ends of the cabling, at the unit and the connected device, are connected properly.</li><li>• Verify the connected device and unit are both powered <i>on</i> and operating correctly.</li><li>• If the other procedures don't resolve the problem, try using a different port or a different cable.</li></ul>
⑨	EPS power is not available.	Check the log file of the connected switch for more detailed information. Possible causes are an over-current condition on the port; a failure to successfully communicate with a connected device; a failed EPS power supply in the unit. Try disconnecting, then reconnecting the EPS cable. Wait three to four seconds for the device to successfully communicate for EPS power. Also try another EPS cable. If this fails to restore EPS power, call your HP-authorized LAN dealer, or use the electronic support services from HP to get assistance. See the Customer Support/Warranty booklet for more information.

---

## Diagnostic Tests

### Testing the HP 600 RPS/EPS by Resetting It

If you believe that the HP 600 RPS/EPS is not operating correctly, you can reset the unit to test its circuitry and operating code. To reset an HP 600 RPS/EPS, unplug and plug in the power cord (power-cycling).

---

#### **Note**

Use caution when power cycling the HP 600 RPS/EPS as this may affect switches receiving operating power from the unit.

Power-cycling the HP 600 RPS/EPS causes the unit to perform its power-on self test, which normally resolves any temporary operational problems.

### Checking the Unit's LEDs

The self test passes if the Fault LED on the front of the HP 600 RPS/EPS goes off after approximately 5 seconds. If this LED stays on longer than 15 seconds or begins blinking, there may be a problem with the unit.

See “Diagnosing with the LEDs” on page 3-2 for information on interpreting the LED patterns.

### Testing Cabling

EPS or RPS cables that fail to provide a link or provide an unreliable link between the HP 600 RPS/EPS and the connected device may be faulty. To verify your cable, try using it to connect to a device that is known to operate correctly or try using a different port. If the problem persists, replace it with another cable.

## HP Customer Support Services

If you are still having trouble with your HP 600 RPS/EPS, Hewlett-Packard offers support 24 hours a day, seven days a week through a number of automated electronic services. See the Customer Support/Warranty booklet that came with your HP 600 RPS/EPS for information on how to use these services to get technical support. The HP ProCurve web site, *<http://www.hp.com/go/hpprocurve>* also provides up-to-date support information under “product support.”

Additionally, your HP-authorized network reseller can provide you with assistance, both with services that they offer and with services offered by HP.

# Specifications

---

## Physical

<b>Width:</b>	44.3 cm (17.4 in)
<b>Depth:</b>	32.6 cm (12.8 in)
<b>Height:</b>	4.4 cm (1.7 in)
<b>Weight:</b>	5.3 kg (11.68 lbs)

## Electrical

The unit automatically adjusts to any voltage between 100-240 volts and either 50 or 60 Hz.

<b>AC voltage:</b>	100-240 volts
<b>Maximum current:</b>	9 -5 A
<b>Frequency range:</b>	50/60 Hz
<b>Power consumption:</b>	821 watts

## Environmental

	<b>Operating</b>	<b>Non-Operating</b>
<b>Temperature:</b>	0°C to 55°C (32°F to 131°F)	-40°C to 70°C (-40°F to 158°F)
<b>Relative humidity: (non-condensing)</b>	15% to 95% at 40°C (104°F)	90% maximum at 65°C (149°F)
<b>Maximum altitude:</b>	4.6 Km (15,000 ft)	4.6 Km (15,000 ft)

## Acoustic

Geraeuschemission  $L_{wA}=59.2$  dB am fiktiven Arbeitsplatz nach DIN 45635 T.19

Noise Emission  $L_{wA}=59.2$  dB at virtual workspace according to DIN 45635 T.19

## Connectors

- EPS Ports: 2x7-pin Micro-Fit 3mm
- RPS Ports: 2x7-pin Mini-Fit 4.2mm

## Safety

Complies with:

- EN60950 / IEC 60950
- CSA 22.2 No. 950
- UL 60950

## EMC Compliance (Class A)

Complies with:

- FCC Part 15.107
- ICES-003 (Canada)
- VCCI
- CISPR-22

## Immunity

- CISPR-24

# Connectors and Cables

---

This appendix includes connector and cable information for cables that should be used with the HP 600 RPS/EPS, including minimum pin-out information and specifications for EPS and RPS cables.

## HP 600 RPS/EPS Ports

The EPS and RPS ports on the unit's back panel accept only the EPS and RPS cables included with the HP 600 RPS/EPS. These cables are described on the next page.

---

**Caution**

---

Use only the EPS and RPS cables supplied with the unit. Use of other cables may result in damage to the equipment.

## HP 600 RPS/EPS Connector Pin-Outs

The HP 600 RPS/EPS includes two EPS ports and six RPS ports. The EPS ports must be connected to HP PoE switches using the provided EPS cable. The RPS ports must be connected to HP ProCurve switches using the provided RPS cables.

### EPS Cable for HP PoE Switch Connections

The EPS cables supplied with the HP 600 RPS/EPS must be used for all EPS connections.

#### Connector Diagram

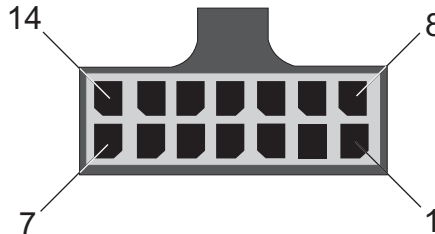

#### Pin Assignments

Pins	Signal Name	Signal Description
1	nINT	A signal from the HP 600 RPS/EPS to the attached device that indicates an interrupt is requested.
2	SDA	The control signal from the attached switch.
3	CGND	A ground connection to the shell of the chassis and the cable to restrict EMI within the cable assembly.
4,7,8,14	50RET	The positive side of the isolated 50V supply.
5,6,12,13	-50V	The negative side of the isolated 50V supply.
8	DCOM	Provides a ground return and reference for the control and status signals from the attached device.
9	SCL	The clock signal generated by the attached device.
10	nPRSNT	Indicates to the HP 600 RPS/EPS that an attached device is present.

## RPS Cable for HP ProCurve Switch Connections

The RPS cables supplied with the HP 600 RPS/EPS must be used for all connections.

### Connector Diagram

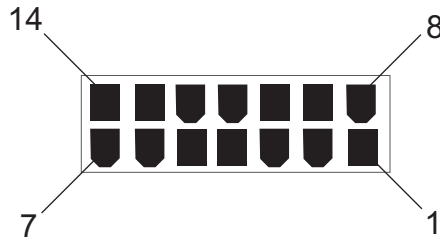

### Pin Assignments

Pins	Signal Name	Signal Description
1	GND	12V power return
2	-	<i>Not used</i>
3,4,5,6	12V	12V power from the HP 600 RPS/EPS
7	GND	12V power return
8	GND	12V power return
9	-	<i>Not used</i>
10	RPS_Present	RPS present signal from HP 600 RPS/EPS
11	Status_1	Provides the condition of the HP 600 RPS/EPS to the attached switch
12	Status_2	Provides the condition of the HP 600 RPS/EPS to the attached switch
13	Power_Good	Power Good signal to the HP 600 RPS/EPS
14	GND	12V power return

— *This page is intentionally unused.* —

# Safety and EMC Regulatory Statements

---

## Safety Information



Documentation reference symbol. If the product is marked with this symbol, refer to the product documentation to get more information about the product.

### WARNING

A WARNING in the manual denotes a hazard that can cause injury or death.

### CAUTION

A CAUTION in the manual denotes a hazard that can damage equipment.

Do not proceed beyond a WARNING or CAUTION notice until you have understood the hazardous conditions and have taken appropriate steps.

### Grounding

This product is a safety class I compliant product and has a protective earthing terminal. There must be an uninterruptible safety earth ground from the main power source to the product's power cord or supplied power cord set. Whenever it is likely that the protection has been impaired, disconnect the power cord until the ground has been restored..

For LAN cable grounding:

- If your LAN covers an area served by more than one power distribution system, be sure their safety grounds are securely interconnected.
- LAN cables may occasionally be subject to hazardous transient voltages (such as lightning or disturbances in the electrical utilities power grid). Handle exposed metal components of the network with caution.

### Servicing

There are no user-serviceable parts inside this product. Any servicing, adjustment, maintenance, or repair must be performed only by service-trained personnel.

This product does not have a power switch; it is powered on when the power cord is plugged in.

## Informations concernant la sécurité



Symbole de référence à la documentation. Si le produit est marqué de ce symbole, reportez-vous à la documentation du produit afin d'obtenir des informations plus détaillées.

### WARNING

Dans la documentation, un WARNING indique un danger susceptible d'entraîner des dommages corporels ou la mort.

### CAUTION

Un texte de mise en garde intitulé CAUTION indique un danger susceptible de causer des dommages à l'équipement.

Ne continuez pas au-delà d'une rubrique WARNING ou CAUTION avant d'avoir bien compris les conditions présentant un danger et pris les mesures appropriées.

Cet appareil est un produit de classe I et possède une borne de mise à la terre. La source d'alimentation principale doit être munie d'une prise de terre de sécurité installée aux bornes du câblage d'entrée, sur le cordon d'alimentation ou le cordon de raccordement fourni avec le produit. Lorsque cette protection semble avoir été endommagée, débrancher le cordon d'alimentation jusqu'à ce que la mise à la terre ait été réparée.

Mise à la terre du câble de réseau local:

- si votre réseau local s'étend sur une zone desservie par plus d'un système de distribution de puissance, assurez-vous que les prises de terre de sécurité soient convenablement interconnectées.
- Les câbles de réseaux locaux peuvent occasionnellement être soumis à des surtensions transitoires dangereuses (telles que la foudre ou des perturbations dans le réseau d'alimentation public). Manipulez les composants métalliques du réseau avec précautions.

Aucune pièce contenue à l'intérieur de ce produit ne peut être réparée par l'utilisateur. Tout dépannage, réglage, entretien ou réparation devra être confié exclusivement à un personnel qualifié.

Cet appareil ne comporte pas de commutateur principal ; la mise sous tension est effectuée par branchement du cordon d'alimentation.

---

## Hinweise zur Sicherheit



Symbol für Dokumentationsverweis. Wenn das Produkt mit diesem Symbol markiert ist, schlagen Sie bitte in der Produktdokumentation nach, um mehr Informationen über das Produkt zu erhalten.

### WARNING

Eine WARNING in der Dokumentation symbolisiert eine Gefahr, die Verletzungen oder sogar Todesfälle verursachen kann.

### CAUTION

CAUTION in der Dokumentation symbolisiert eine Gefahr, die das Gerät beschädigen kann.

Fahren Sie nach dem Hinweis WARNING oder CAUTION erst fort, nachdem Sie den Gefahrenzustand verstanden und die entsprechenden Maßnahmen ergriffen haben.

Dies ist ein Gerät der Sicherheitsklasse I und verfügt über einen schützenden Erdungsterminal. Der Betrieb des Geräts erfordert eine ununterbrochene Sicherheitserdung von der Hauptstromquelle zu den Geräteingabeterminals, den Netzkabeln oder dem mit Strom belieferten Netzkabelsatz voraus. Sobald Grund zur Annahme besteht, daß der Schutz beeinträchtigt worden ist, das Netzkabel aus der Wandsteckdose herausziehen, bis die Erdung wiederhergestellt ist.

Für LAN-Kabelerdung:

- Wenn Ihr LAN ein Gebiet umfaßt, das von mehr als einem Stromverteilungssystem beliefert wird, müssen Sie sich vergewissern, daß die Sicherheitserdungen fest untereinander verbunden sind.
- LAN-Kabel können gelegentlich gefährlichen Übergangsspannungen ausgesetzt werden (beispielsweise durch Blitz oder Störungen in dem Starkstromnetz des Elektrizitätswerks). Bei der Handhabung exponierter Metallbestandteile des Netzwerkes Vorsicht walten lassen.

Dieses Gerät enthält innen keine durch den Benutzer zu wartenden Teile. Wartungs-, Anpassungs-, Instandhaltungs- oder Reparaturarbeiten dürfen nur von geschultem Bedienungspersonal durchgeführt werden.

Dieses Gerät hat keinen Netzschalter; es wird beim Anschließen des Netzkabels eingeschaltet.

## Considerazioni sulla sicurezza



Simbolo di riferimento alla documentazione. Se il prodotto è contrassegnato da questo simbolo, fare riferimento alla documentazione sul prodotto per ulteriori informazioni su di esso.

### WARNING

La dicitura **WARNING** denota un pericolo che può causare lesioni o morte.

### CAUTION

La dicitura **CAUTION** denota un pericolo che può danneggiare le attrezzature.

Non procedere oltre un avviso di **WARNING** o di **CAUTION** prima di aver compreso le condizioni di rischio e aver provveduto alle misure del caso.

Questo prodotto è omologato nella classe di sicurezza I ed ha un terminale protettivo di collegamento a terra. Dev'essere installato un collegamento a terra di sicurezza, non interrompibile che vada dalla fonte d'alimentazione principale ai terminali d'entrata, al cavo d'alimentazione oppure al set cavo d'alimentazione fornito con il prodotto. Ogniqualvolta vi sia probabilità di danneggiamento della protezione, disinserite il cavo d'alimentazione fino a quando il collegaento a terra non sia stato ripristinato.

Per la messa a terra dei cavi LAN:

- se la vostra LAN copre un'area servita da più di un sistema di distribuzione elettrica, accertatevi che i collegamenti a terra di sicurezza siano ben collegati fra loro;
- i cavi LAN possono occasionalmente andare soggetti a pericolose tensioni transitorie (ad esempio, provocate da lampi o disturbi nella griglia d'alimentazione della società elettrica); siate cauti nel toccare parti esposte in metallo della rete.

Nessun componente di questo prodotto può essere riparato dall'utente. Qualsiasi lavoro di riparazione, messa a punto, manutenzione o assistenza va effettuato esclusivamente da personale specializzato.

Questo apparato non possiede un commutatore principale; si mette scotto tensione all'inserirsi il cavo d'alimentazione.

## Consideraciones sobre seguridad



Símbolo de referencia a la documentación. Si el producto va marcado con este símbolo, consultar la documentación del producto a fin de obtener mayor información sobre el producto.

### WARNING

Una WARNING en la documentación señala un riesgo que podría resultar en lesiones o la muerte.

### CAUTION

Una CAUTION en la documentación señala un riesgo que podría resultar en averías al equipo.

No proseguir después de un símbolo de WARNING o CAUTION hasta no haber entendido las condiciones peligrosas y haber tomado las medidas apropiadas.

Este aparato se enmarca dentro de la clase I de seguridad y se encuentra protegido por una borna de puesta a tierra. Es preciso que exista una puesta a tierra continua desde la toma de alimentación eléctrica hasta las bornas de los cables de entrada del aparato, el cable de alimentación o el juego de cable de alimentación suministrado. Si existe la probabilidad de que la protección a tierra haya sufrido desperfectos, desenchufar el cable de alimentación hasta haberse subsanado el problema.

Puesta a tierra del cable de la red local (LAN):

- Si la LAN abarca un área cuyo suministro eléctrico proviene de más de una red de distribución de electricidad, cerciorarse de que las puestas a tierra estén conectadas entre sí de modo seguro.
- Es posible que los cables de la LAN se vean sometidos de vez en cuando a voltajes momentáneos que entrañen peligro (rayos o alteraciones en la red de energía eléctrica). Manejar con precaución los componentes de metal de la LAN que estén al descubierto.

Este aparato no contiene pieza alguna susceptible de reparación por parte del usuario. Todas las reparaciones, ajustes o servicio de mantenimiento debe realizarlos solamente el técnico.

Este producto no tiene interruptor de potencia; se activa cuando se enchufa el cable de alimentación.

## Safety Information (Japan)

安全性の考慮

安全記号



マニュアル参照記号。製品にこの記号がついている場合はマニュアルを参照し、注意事項等をご確認ください。

WARNING マニュアル中の「WARNING」は人身事故の原因となる危険を示します。

CAUTION マニュアル中の「CAUTION」は装置破損の原因となる危険を示します。

「WARNING」や「CAUTION」の項は飛ばさないで必ずお読みください。危険性に関する記載事項をよく読み、正しい手順に従った上で次の事項に進んでください。

これは安全性クラス I の製品で保護用接地端子を備えています。主電源から製品の入力配線端子、電源コード、または添付の電源コード・セットまでの間、切れ目のない安全接地が存在することが必要です。もしこの保護回路が損なわれたことが推測されるときは、接地が修復されるまで電源コードを外しておいてください。

LAN ケーブルの接地に関して:

- もし貴社の LAN が複数の配電システムにより電力を受けている領域をカバーしている場合には、それらのシステムの安全接地が確実に相互に結合されていることを確認してください。
- LAN ケーブルは時として危険な過度電圧（例えば雷や、配電設備の電力網での障害）にさらされることがあります。露出した金属部分の取扱いには十分な注意をはらってください。

本製品の内部にはユーザーが修理できる部品はありません。サービス、調整、保守および修理はサービス訓練を受けた専門家におまかせください。

本製品には電源スイッチがありません。電源コードを接続したとき電源入となります。

# Safety Information (China)

## HP 网络产品使用安全手册

### 使用须知

欢迎使用惠普网络产品，为了您及仪器的安全，请您务必注意如下事项：

1. 仪器要和地线相接，要使用有正确接地插头的电源线，使用中国国家规定的220V电源。
2. 避免高温和尘土多的地方，否则易引起仪器内部部件的损坏。
3. 避免接近高温，避免接近直接热源，如直射阳光、暖气等其它发热体。
4. 不要有异物或液体落入机内，以免部件短路。
5. 不要将磁体放置于仪器附近。

### 警告

为防止火灾或触电事故，请不要将该机放置于淋雨或潮湿处。

### 安装

安装辅助管理模块，请参看安装指南。

### 保修及技术支持

如果您按照以上步骤操作时遇到了困难，或想了解其它产品性能，请按以下方式与我们联系。

如是硬件故障：

1. 与售出单位或当地维修机构联系。
2. 中国惠普有限公司维修中心地址：  
北京市海淀区知春路49号希格玛大厦  
联系电话：010-62623888 转 6101  
邮政编码：100080

如是软件问题：

1. 惠普用户响应中心热线电话：010-65645959
2. 传真自动回复系统：010-65645735

---

## EMC Regulatory Statements

### U.S.A.

#### FCC Class A

This equipment has been tested and found to comply with the limits for a Class A digital device, pursuant to Part 15 of the FCC Rules. These limits are designed to provide reasonable protection against interference when the equipment is operated in a commercial environment. This equipment generates, uses, and can radiate radio frequency energy and, if not installed and used in accordance with the instruction manual, may cause interference to radio communications. Operation of this equipment in a residential area may cause interference in which case the user will be required to correct the interference at his own expense.

### Canada

This product complies with Class A Canadian EMC requirements.

### Australia/New Zealand



This product complies with Australia/New Zealand EMC Class A requirements.

### Japan

#### VCCI Class A

この装置は、情報処理装置等電波障害自主規制協議会（VCCI）の基準に基づくクラスA情報技術装置です。この装置を家庭環境で使用すると電波妨害を引き起こすことがあります。この場合には使用者が適切な対策を講ずるよう要求されることがあります。

## Korea

사용자 안내문 : A 급기기

이기는 업무용으로 전자파 적합등록을 받은 기기 이오니, 판매자 또는 사용자는 이점을 주의하시기 바라며, 만약 잘못 구입하셨을 때에는 구입한 곳에서 비업무용으로 교환하시기 바랍니다.

## Taiwan

警告使用者：這是甲類的資訊產品，在居住的環境中使用時，可能會造成射頻干擾，在這種情況下，使用者會被要求採取某些適當的對策。

## EU Declaration of Conformity

### DECLARATION OF CONFORMITY

according to ISO/IEC Guide 22 and EN45014

**Manufacturer's Name:** Hewlett-Packard Company

**Manufacturer's Address:** 8000 Foothills Blvd.  
Roseville, CA 95747-5502  
U.S.A.

**declares that the product:**

**Product Name:** HP ProCurve 600 RPS/EPS,

**Model Number:** J8168A

**Regulatory Model Number:** RSVLC-0303

**conforms to the following Product Specifications:**

**Safety:** EN60950 (2000) / IEC 950 (1999)

**EMC:** EN 55022 (1998) / CISPR-22 (1997) Class A  
EN55024 (1998) / CISPR-24 (1997)  
EN 61000-3-2 (2000) / IEC 61000-3-2 (2000) Harmonics  
EN 61000-3-3 (1995) / IEC 61000-3-3 (1994) Flicker

**Supplementary Information:**

The product herewith complies with the requirements of the Low Voltage Directive 73/23/EEC and the EMC Directive 89/336/EEC and carries the CE mark.

Tested with Hewlett-Packard Co. products only.

Roseville, October 31, 2003



Mike Avery,  
Regulatory Engineering Manager

European Contact: Your local Hewlett-Packard Sales and Service Office or Hewlett-Packard GmbH,  
Department TRE, Herrenberger Strasse 140, D-71034 Böblingen (FAX:+49-7031-14-3143).

---

# Index

## B

- back of unit ... 1-2
  - EPS ports ... 1-2
  - EPS/RPS ports ... 1-2
  - power connector ... 1-2
  - RPS ports ... 1-2
- basic troubleshooting tips ... 3-1
- blinking LEDs
  - error indications ... 3-2

## C

- cabinet
  - mounting the unit in ... 2-5
- cables
  - connecting cables to the unit ports ... 2-8
  - EPS connector pin-outs ... B-2
  - required types ... 2-4
  - requirements ... 2-4
  - testing ... 3-5
- cables, EPS ... B-2
  - pin-outs ... B-2
- cables, EPS connector pin-outs ... B-2
- cables, RPS ... B-3
  - unit-to-switch connection ... B-3
- cabling ... 2-4
- connecting the unit to a power source ... 2-10
- connector specifications ... A-2

## D

- description ... 1-2
  - back of unit ... 1-2
  - LEDs ... 1-3
  - unit ... 1-1
- diagnostic tests ... 3-5
  - checking the LEDs ... 3-5
  - testing cabling ... 3-5
  - testing the unit only ... 3-5

## E

- electrical specifications, unit ... A-1
- EMC regulatory statements ... C-8

- emissions specifications, unit ... A-2
- environmental specifications, unit ... A-1
- EPS cable
  - pin-outs ... B-2
  - unit-to-device connection ... B-2
- EPS connections
  - sample topology ... 2-12
- EPS ports
  - location on unit ... 1-2
  - operation description ... 1-2

## F

- Fan Status LED ... 1-3
- Fault LED ... 1-3
  - behavior during self test ... 2-11
  - behaviors ... 1-3
  - blinking definition ... 1-3–1-4
  - showing error conditions ... 3-2
- front of unit
  - LEDs ... 1-3

## H

- horizontal surface
  - mounting unit on ... 2-7

## I

- included parts ... 2-1
- installation
  - cable requirements ... 2-4
  - connecting the unit to a power source ... 2-10
  - horizontal surface mounting ... 2-7
  - location considerations ... 2-4
  - precautions ... 2-3
  - rack or cabinet mounting ... 2-5
  - site preparation ... 2-4
  - summary of steps ... 2-2

## L

### LEDs

- behavior during self test ... 2-11
- blinking definition ... 1-3–1-4
- checking during troubleshooting ... 3-5
- descriptions of ... 1-3
- error indications ... 3-2
- Fan Status ... 1-3
- Fault ... 1-3
  - behavior during self test ... 2-11
  - showing error conditions ... 3-2
- location on unit ... 1-3
- port
  - description ... 1-3
- Power ... 1-3
  - behavior during self test ... 2-11
- Self Test
  - behavior during self test ... 2-11
- location for the unit, considerations ... 2-4

## M

### mounting the unit

- in a rack or cabinet ... 2-5
- on a horizontal surface ... 2-7

## N

### network devices

- connecting to the unit ... 2-8

## P

- parts, included with the unit ... 2-1
- physical specifications, unit ... A-1
- pin-outs
  - EPS cables ... B-2
- port LEDs
  - description ... 1-3
  - location on unit ... 1-3
  - normal operation ... 2-11
- ports
  - connecting to ... 2-8
  - connections ... 2-8
  - location on unit ... 1-2
  - RPS, location on unit ... 1-2
  - standards compliance ... A-2
- power connector ... 1-2

### Power LED ... 1-3

- behavior during self test ... 2-11
- behaviors ... 1-3

### power source

- connecting the unit to ... 2-10

### precautions

- mounting the unit ... 2-3
- power requirements ... 2-3

### preparing the installation site ... 2-4

## R

### rack

- mounting the unit in ... 2-5

### regulatory statements ... C-8

### resetting the unit

- troubleshooting procedure ... 3-5

### RPS cable

- unit-to-switch connection ... B-3

### RPS connections

- sample topology ... 2-13

### RPS ports

- location on unit ... 1-2
- operation description ... 1-2

## S

### safety and regulatory statements ... C-1

### safety specifications ... A-2

### self test

- Fault LED behavior ... 2-11
- LED behavior during ... 2-11
- Power LED behavior ... 2-11

### Self Test LED

- behavior during self test ... 2-11

### specifications

- connectors ... A-2
- electrical ... A-1
- emissions ... A-2
- environmental ... A-1
- physical ... A-1
- safety ... A-2

### summary

- of unit installation ... 2-2

## T

### testing

- cabling ... 3-5
- checking the LEDs ... 3-5
- diagnostic tests ... 3-5
- unit operation ... 3-5

### tips for troubleshooting ... 3-1

### topologies

- effects of improper topology ... 3-1
- samples of ... 2-12

### troubleshooting ... 3-1

- basic tips ... 3-1
- checking the LEDs ... 3-5
- common problems ... 3-1
- diagnostic tests ... 3-5
- effects of improper topology ... 3-1
- testing the cables ... 3-5
- testing the unit ... 3-5

## U

### unit

- connecting to a power source ... 2-10
- electrical specifications ... A-1
- emissions specifications ... A-2
- environmental specifications ... A-1
- included parts ... 2-1
- mounting in a rack or cabinet ... 2-5
- mounting on horizontal surface ... 2-7
- physical specifications ... A-1

### unit operation

- verifying after installation ... 2-11

— *This page is intentionally unused.* —





Technical information in this document  
is subject to change without notice.

©Copyright 2003  
Hewlett-Packard Development Company, L.P.  
Reproduction, adaptation, or translation  
without prior written permission is prohibited  
except as allowed under the copyright laws.

Printed in Taiwan  
November 2003

Manual Part Number  
5990-6035

