



Release Notes:

Version E.07.37 Software

for the HP ProCurve Series 5300XL Switches

Release E.07.37 supports these switches:

- HP ProCurve Switch 5304XL (J4850A)
- HP ProCurve Switch 5308XL (J4819A)
- HP ProCurve Switch 5348XL (J4849A) – 48-port bundle in Switch 5304XL chassis
- HP ProCurve Switch 5372XL (J4848A) – 72-port bundle in Switch 5308XL chassis

These release notes include information on the following:

- Downloading switch software and Documentation from the Web
- Software features available in release E.07.xx
- Clarification of operating details for certain software features
- A listing of software fixes included in releases E.06.01 through E.07.37

Caution

The startup-config file saved under version E.07.2x or greater, is NOT backward-compatible with previous software versions. Users are advised to save a copy of the pre-E.07.2x startup-config file BEFORE UPGRADING to E.07.21 or greater, in case there is ever a need to revert to pre-E.07.2x software. Instructions for saving a copy of the startup-config file are found in the “Transferring Switch Configurations” section of Appendix A in the Management and Configuration Guide (included in PDF format on the Product Documentation CD-ROM) shipped with the switch, and also available on the HP ProCurve web site. (Refer to [“To Download Product Documentation:” on page 1.](#))

Software Update Notice

Check the HP ProCurve web site frequently for *free* software updates for the various HP ProCurve switches you may have in your network ([see page 1](#)).

© Copyright 2001, 2003 Hewlett-Packard Company, LP.
The information contained herein is subject to change
without notice.

Publication Number

5990-6004
October 2003
Edition 3

Applicable Product

HP ProCurve Switch 5304XL	(J4850A)
HP ProCurve Switch 5308XL	(J4819A)
HP ProCurve Switch 5348XL	(J4849A)
HP ProCurve Switch 5372XL	(J4848A)

Trademark Credits

Microsoft®, Windows®, and Windows NT® are US registered trademarks of Microsoft Corporation. Adobe® and Acrobat® are trademarks of Adobe Systems Incorporated. Java™ is a US trademark of Sun Microsystems, Inc.

Software Credits

SSH on HP ProCurve Switches is based on the OpenSSH software toolkit. This product includes software developed by the OpenSSH Project for use in the OpenSSH Toolkit. For more information on OpenSSH, visit

[http:// www.openssh.com](http://www.openssh.com).

SSL on HP ProCurve Switches is based on the OpenSSL software toolkit. This product includes software developed by the OpenSSL Project for use in the OpenSSL Toolkit. For more information on OpenSSL, visit

<http://www.openssl.org>.

This product includes cryptographic software written by Eric Young (eay@cryptsoft.com). This product includes software written by Tim Hudson (tjh@cryptsoft.com)

Hewlett-Packard Company
8000 Foothills Boulevard, m/s 5551
Roseville, California 95747-5551
<http://www.hp.com/go/hpprocurve>

Disclaimer

The information contained in this document is subject to change without notice.

HEWLETT-PACKARD COMPANY MAKES NO WARRANTY OF ANY KIND WITH REGARD TO THIS MATERIAL, INCLUDING, BUT NOT LIMITED TO, THE IMPLIED WARRANTIES OF MERCHANTABILITY AND FITNESS FOR A PARTICULAR PURPOSE. Hewlett-Packard shall not be liable for errors contained herein or for incidental or consequential damages in connection with the furnishing, performance, or use of this material.

The only warranties for HP products and services are set forth in the express warranty statements accompanying such products and services. Nothing herein should be construed as constituting an additional warranty. HP shall not be liable for technical or editorial errors or omissions contained herein.

Hewlett-Packard assumes no responsibility for the use or reliability of its software on equipment that is not furnished by Hewlett-Packard.

Warranty

See the Customer Support/Warranty booklet included with the product.

A copy of the specific warranty terms applicable to your Hewlett-Packard products and replacement parts can be obtained from your HP Sales and Service Office or authorized dealer.

Contents

Software Management	1
Downloading Switch Documentation and Software from the Web	1
Downloading Software to the Switch	2
TFTP Download from a Server	3
Xmodem Download From a PC or Unix Workstation	4
Saving Configurations While Using the CLI	6
HP ProCurve Switch Software Key	6
Minimum Software Versions for Series 5300XL Switch Features	7
Clarifications	8
Heterogeneous Switch Meshing	8
Switch Mesh Considerations When Upgrading to Release E.07.27 or Greater	9
Upgrading the OS in Meshed, Series 5300XL Switches	9
Upgrading in Heterogeneous Meshes	9
OS/Web/Java Compatibility Table	10
Time Zone Offset	10
Manual Errata	10
Enhancements	11
Release E.07.37 Enhancements	11
Release E.07.34 Enhancements	11
Release E.07.30 Enhancements	11
Release E.07.29 Enhancements	11
Release E.07.27 Enhancements	11
Release E.07.22 Enhancements	12
Release E.07.21 Enhancements	12
Release E.06.10 Enhancements	13
Release E.06.05, E.06.03, and E.06.02 Enhancements	13
Release E.06.01 Enhancements	13

Software Fixes in Release E.06.xx and E.07.xx	15
Release E.07.37	15
Release E.07.34	15
Release E.07.30	16
Release E.07.29	16
Release E.07.27	17
Release E.07.22	17
Release E.07.21	18
Release E.06.10	22
Release E.06.05	23
Release E.06.03	23
Release E.06.02	23
Release E.06.01	23

Software Management

Downloading Switch Documentation and Software from the Web

You can download software updates and the corresponding product documentation from HP's ProCurve web site as described below.

To Download a Software Version:

1. Go to HP's ProCurve web site at:
<http://www.hp.com/go/hpprocurve>.
2. Click on **software** (in the sidebar).
3. Under **latest software**, click on **switches**.

To Download Product Documentation: You will need the Adobe® Acrobat® Reader to view, print, and/or copy the product documentation.

1. Go to HP's ProCurve web site at <http://www.hp.com/go/hpprocurve>.
2. Click on **technical support**, then **manuals**.
3. Click on the name of the product for which you want documentation.
4. On the resulting web page, double-click on a document you want.
5. When the document file opens, click on the disk icon  in the Acrobat® toolbar and save a copy of the file.

Downloading Software to the Switch

Caution

The startup-config file generated by the latest software release may not be backward-compatible with the same file generated by earlier software releases. Refer to the “[Caution](#)” on the front page.

HP periodically provides switch operating system (OS) updates through the HP ProCurve web site (<http://www.hp.com/go/hpprocurve>). After you acquire the new OS file, you can use one of the following methods for downloading the operating system (OS) code to the switch:

- For a TFTP transfer from a server, do either of the following:
 - Click on **Download OS** in the Main Menu of the switch’s menu interface and use the (default) **TFTP** option.
 - Use the **copy tftp** command in the switch’s CLI (see below).
- For an Xmodem transfer from a PC or Unix workstation, do either of the following:
 - Click on **Download OS** in the Main Menu of the switch’s menu interface and select the **Xmodem** option.
 - Use the `copy xmodem` command in the switch’s CLI (page 4).
- HP’s SNMP Download Manager included in HP TopTools for Hubs & Switches
- A switch-to-switch file transfer

Note

Downloading a new OS does not change the current switch configuration. The switch configuration is contained in a separate file that can also be transferred, for example, for archive purposes or to be used in another switch of the same model.

This section describes how to use the CLI to download an OS to the switch. You can also use the menu interface for OS downloads. For more information, refer to the *Management and Configuration Guide* for your switch.

TFTP Download from a Server

Syntax: `copy tftp flash <ip-address> <remote-os-file> [< primary | secondary >]`

Note that if you do not specify the flash destination, the TFTP download defaults to the primary flash.

For example, to download an OS file named `E_07_27.swi` from a TFTP server with the IP address of `10.28.227.103`:

1. Execute the copy command as shown below:

```
HPswitch# copy tftp flash 10.28.227.103 E_07_27.swi
Device will be rebooted, do you want to continue [y/n]? y
00224K _
```

2. When the switch finishes downloading the OS file from the server, it displays this progress message:

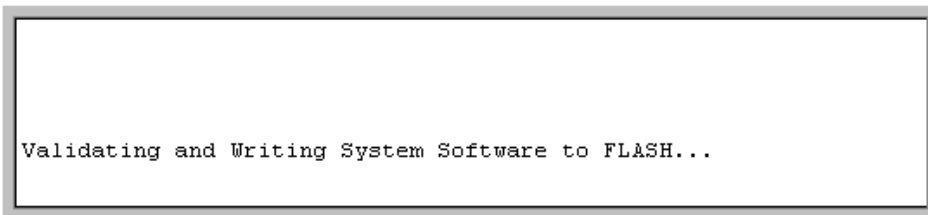
A screenshot of a terminal window with a double-line border. The text inside the window reads: "Validating and Writing System Software to FLASH...".

```
Validating and Writing System Software to FLASH...
```

Figure 1. Message Indicating the Switch Is Writing the Downloaded Software to Flash Memory

3. After the switch writes the downloaded software to flash memory, you will see this screen:

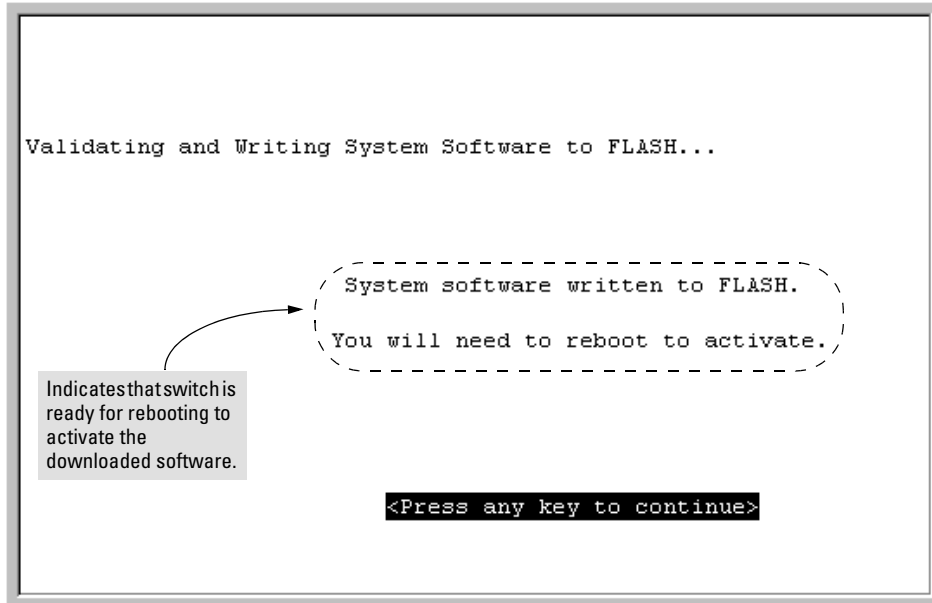

Figure 2. Message Indicating the Switch Is Ready To Activate the Downloaded Software

4. Reboot the switch.

After the switch reboots, it displays the CLI or Main Menu, depending on the **Logon Default** setting last configured in the menu's Switch Setup screen.

Xmodem Download From a PC or Unix Workstation

This procedure assumes that:

- The switch is connected via the Console RS-232 port on a PC operating as a terminal. (Refer to the Installation Guide you received with the switch for information on connecting a PC as a terminal and running the switch console interface.)
- The switch operating system (OS) is stored on a disk drive in the PC.
- The terminal emulator you are using includes the Xmodem binary transfer feature. (For example, in the Microsoft Windows NT® terminal emulator, you would use the **Send File** option in the **Transfer** drop-down menu.)

Syntax: `copy xmodem flash < unix | pc >`

For example, to download an OS file from a PC:

1. To reduce the download time, you may want to increase the baud rate in your terminal emulator and in the switch to a value such as 57600 bits per second. (The baud rate must be the same in both devices.) For example, to change the baud rate in the switch to 57600, execute this command:

```
HPswitch(config)# console baud-rate 57600
```

(If you use this option, be sure to set your terminal emulator to the same baud rate.)

2. Execute the following command in the CLI:

```
HPswitch(config)# copy xmodem flash pc
Device will be rebooted, do you want to continue [y/n]? y
Press 'Enter' and start XMODEM on your host...
```

3. Execute the terminal emulator commands to begin the Xmodem transfer.

The download can take several minutes, depending on the baud rate used in the transfer.

When the download finishes, the switch automatically reboots itself and begins running the new OS version.

4. To confirm that the operating system downloaded correctly:

```
HPswitch> show system
```

Check the **Firmware revision** line.

```
HP5304XL# show system

Status and Counters - General System Information

System Name       : HP5304XL
System Contact    :
System Location   :

MAC Age Time (sec) : 300

Time Zone         : 0
Daylight Time Rule : None

Firmware revision : E.07.27
ROM Version       : E.05.02
Base MAC Addr     : 0004ea-5e2000
Serial Number     : SG22600588

Up Time          : 9 mins
CPU Util (%)     : 2
Memory - Total   : 19,981,624
              Free : 9,991,960

IP Mgmt - Pkts Rx : 418
          Pkts Tx : 233
Packet - Total   : 1152
        Free     : 642
        Lowest   : 621
        Missed   : 0
```

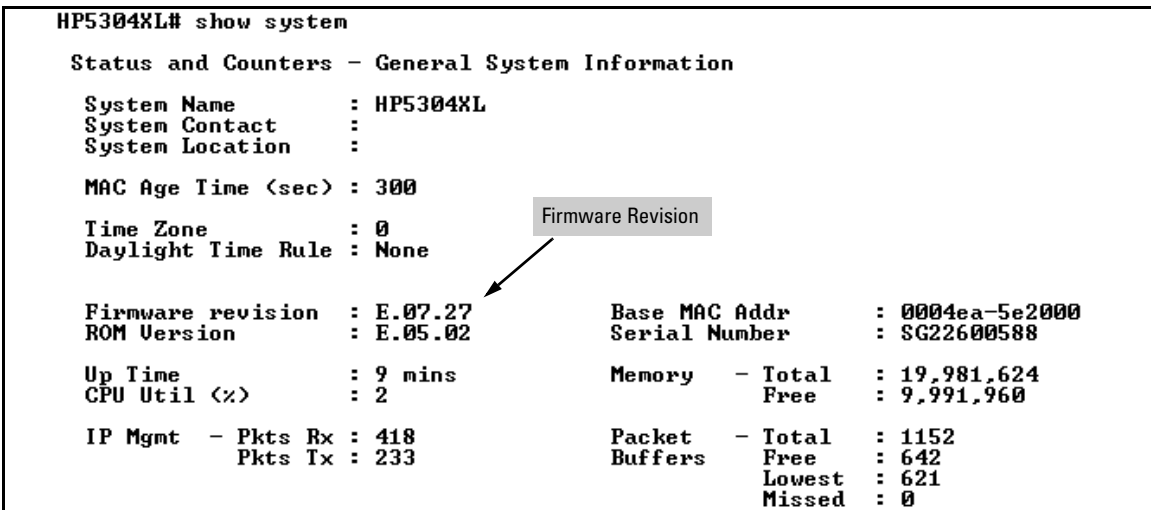

Verifying the

5. If you increased the baud rate on the switch ([step 1](#)), use the same command to return it to its previous setting. (HP recommends a baud rate of 9600 bits per second for most applications.)
(Remember to return your terminal emulator to the same baud rate as the switch.)

Saving Configurations While Using the CLI

The switch operates with two configuration files:

- **Running-Config File:** Exists in volatile memory and controls switch operation. Rebooting the switch erases the current running-config file and replaces it with an exact copy of the current startup-config file. To save a configuration change, you must save the running configuration to the startup-config file.
- **Startup-Config File:** Exists in flash (non-volatile) memory and preserves the most recently-saved configuration as the “permanent” configuration. When the switch reboots for any reason, an exact copy of the current startup-config file becomes the new running-config file in volatile memory.

When you use the CLI to make a configuration change, the switch places the change in the running-config file. If you want to preserve the change across reboots, you must save the change to the startup-config file. Otherwise, the next time the switch reboots, the change will be lost. There are two ways to save configuration changes while using the CLI:

- Execute **write memory** from the Manager, Global, or Context configuration level.
- When exiting from the CLI to the Main Menu, press **[Y]** (for Yes) when you see the “save configuration” prompt:

Do you want to save current configuration [y/n] ?

HP ProCurve Switch Software Key

Software Letter	HP ProCurve Switch
C	1600M, 2400M, 2424M, 4000M, 8000M
E	Series 5300XL (5304XL and 5308XL)
F	Series 2500 (2512 and 2524)
G	Series 4100GL (4104GL and 4108GL)
H	Series 2600 (2626 and 2650) Switches and Switch 6108

Minimum Software Versions for Series 5300XL Switch Features

For Software Features. To view a tabular listing of major switch software features and the minimum software version each feature requires:

1. Visit the HP ProCurve web site at <http://www.hp.com/go/hpprocurve>.
2. Click on **software**.
3. Click on **Minimum Software Version Required by Feature**.

If you are viewing this publication online, just click on [step 3](#) to go directly to the Minimum Software information.

For Switch 5300XL Hardware Accessories.

HP ProCurve Device	Minimum Supported Software Version
J4820A 24-Port 10/100-TX Module	E.05.04
J4821A 4-Port 100/1000-T Module	E.05.04
J4839A Redundant Power Supply (RPS)	E.05.04
J4852A 12-Port 100-FX MTRJ Module	E.06.10
J4878A 4-Port Mini-GBIC Module	E.05.04
J4858A Gigabit-SX-LC Mini-GBIC	E.05.04
J4859A Gigabit-LX-LC Mini-GBIC	E.05.04
J4860A Gigabit-LH-LC Mini-GBIC	E.06.01

Clarifications

Heterogeneous Switch Meshing

When Series 5300XL switches running software release E.07.2x or greater are placed in backward-compatibility mode, they can operate in switch mesh domains that include HP ProCurve 1600M, 2400M, 2424M, 4000M, and 8000M switches. However, because these older switch models use a single-forwarding database, a heterogeneous domain must be free of duplicate MAC addresses on multiple switches and different VLANs. Refer to [figure 3](#) and [figure 4](#):

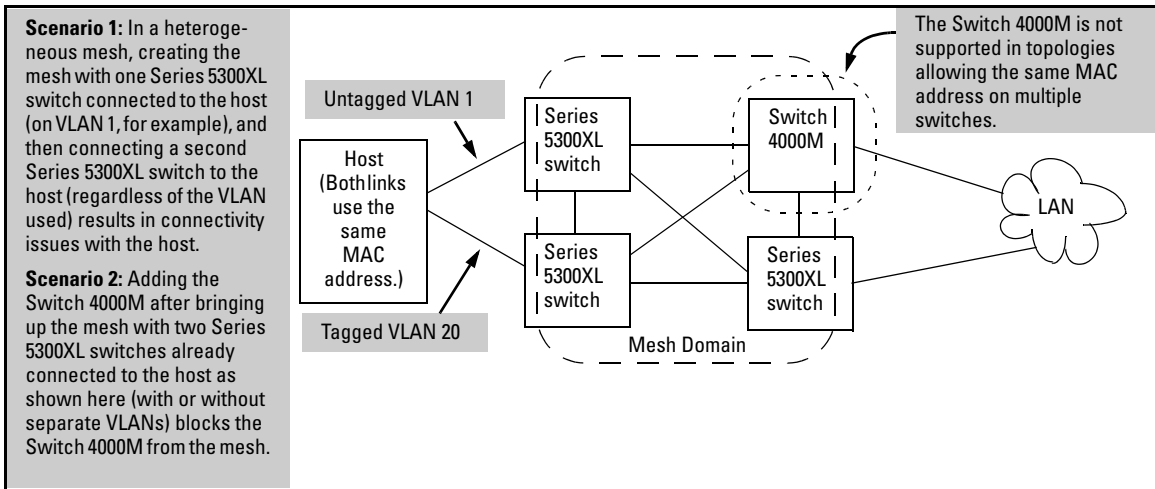

Figure 3. Example of an Unsupported Heterogeneous Topology Where Duplicate MAC Addresses Come Through Different Switches (Regardless of the VLANs Used)

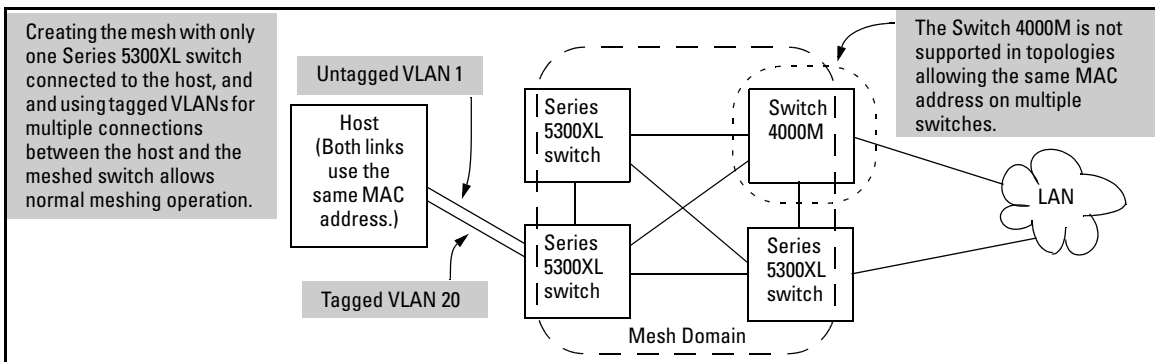

Figure 4. Example of a Supported Heterogeneous Topology Where Duplicate MAC Addresses Come Through Different VLANs on the Same Switch

Note that in [figure 3](#) and [figure 4](#), if all switches are Series 5300XL switches, then you can use either topology.

For more on this topic, refer to “Multiple VLAN Considerations” in the VLAN chapter in edition 7 (or later) of the Management and Configuration Guide for the Series 5300XL switches. (The latest version of this manual is available on the HP ProCurve web site. Refer to [“Downloading Switch Documentation and Software from the Web” on page 1.](#))

Switch Mesh Considerations When Upgrading to Release E.07.27 or Greater

Upgrading the OS in Meshed, Series 5300XL Switches

When performing an OS upgrade in a mesh domain, you must always upgrade all Series 5300XL switches to the same software version.

- Supported switch mesh operation requires all Series 5300XL switches in the mesh to run the same OS version.
- Although a mesh may appear to operate properly with some switches running release E.07.27 (or greater) and other switches running E.06.xx or earlier, this scenario creates an unsupported mesh environment.

Upgrading in Heterogeneous Meshes

If your mesh includes Series 5300XL switches running release E.07.22 or greater *and* any HP ProCurve 1600M/2400M/2424M/4000M/8000M switches, then you must enable mesh interoperability between the two switch families. To do so, execute the following command in the CLI of each Series 5300XL switch in the mesh:

```
HPswitch(config)# mesh backward-compat
```

Note: Until you complete this step, the Series 5300XL switches and the HP ProCurve 1600M/2400M/2424M/4000M/8000M switches *will not interoperate* in the mesh. For more on heterogeneous meshes, refer to the Switch Meshing chapter in the *Management and Configuration Guide* for your Series 5300XL Switch (HP part number 5990-3016, edition 1, February 2003, or a later edition), available on the HP ProCurve web site. (Refer to [“Downloading Switch Documentation and Software from the Web” on page 1.](#))

OS/Web/Java Compatibility Table

The switch web agent supports the following combinations of OS browsers and Java Virtual Machines:

Operating System	Internet Explorer	Netscape Navigator	Java
Windows NT 4.0 SP6	5.00 5.01 5.01, SP1 6.0, SP1	4.7 7.0 7.01	Sun Java 2 Runtime Environment, Ver. 1.4.1 Microsoft Virtual Machine 5.0.38.09
Windows 2000 SP3	5.01, SP1 6.0, SP1	7.0 7.01	
Windows XP Professional XP Hotfix SP2	6.0, SP1	7.0 7.01	

Time Zone Offset

Starting with release E.05.*xx*, the method of configuring the Time Zone for TimeP or SNTP configuration has been updated. Previous switch software for all HP ProCurve switches used positive time offset values for time zones that are West of GMT and negative values for time zones that are East of GMT. The standards indicate that time zones West of GMT should be designated by negative offset values, and time zones East of GMT by positive values. Software version E.05.*xx* updates this configuration method, but if you use the same values for indicating time zones as you did for previous HP ProCurve switches, the time will be set incorrectly on your Series 5300GL switch. For example, for previous HP ProCurve switches, the US Pacific time zone was configured by entering **+480**. With software version E.05.*xx*, the US Pacific time zone must now be configured by entering **-480**.

Manual Errata

In editions 2 and 3 of the *Access Security Guide* (part number 5990-3031), text in the fourth bullet of the list under “General Operating Rules and Notes” incorrectly indicates that the Stacking feature is available in the Series 5300XL switches. Stacking is not offered in these switch models.

Enhancements

Unless otherwise noted, each new release includes the features added in all previous releases.

Release E.07.37 Enhancements

Boot ROM Update, Version E.05.04 — Modifications have been made to Boot ROM to allow for a larger flash memory space to be available for future software releases and switch feature enhancements. The updated Boot ROM is backwards compatible with older software. Downloading E.07.37 will automatically update Boot ROM code upon switch reboot.

You can confirm that the Boot ROM has been updated using the **show flash** command. See the example below:

```
HP ProCurve Switch 5304XL# show flash
Image          Size(Bytes)  Date   Version
-----
Primary Image  : 2901599  09/26/03 E.07.37
Secondary Image : 2784788  08/13/03 E.07.34
Boot Rom Version: E.05.04
Current Boot   : Primary
```

Release E.07.34 Enhancements

Software fixes only; no new enhancements.

Release E.07.30 Enhancements

Software fixes only; no new enhancements.

Release E.07.29 Enhancements

Software fixes only; no new enhancements.

Release E.07.27 Enhancements

Software fixes only; no new enhancements.

Release E.07.22 Enhancements

Software fixes only; no new enhancements.

Release E.07.21 Enhancements

To Locate Publications Supporting E.07.21 Features:

1. Go to HP's ProCurve web site at <http://www.hp.com/go/hpprocurve>.
2. Click on **technical support**, then **manuals**.
3. Click on the name of the product for which you want documentation.
4. Select the document indicated in the enhancement description ([table 1](#)) for the desired feature.

(HP recommends periodically visiting the HP ProCurve web site to keep up-to-date with the latest documentation available for HP ProCurve Series 5300XL switch products.)

Table 1. Release E.07.21 Enhancements

Enhancement	Overview
Access Control Lists (ACLs)	Layer 3 IP filtering with ACLs lets you improve network performance and restrict network use by creating policies for switch management access and application access security. ¹
Debug and Syslog Messaging Operation	These features provide a method for recording messages you can use to help in debugging network-level problems such as routing misconfigurations and other protocol details. ¹
SNMPv3	The Series 5300XL switches now support SNMPv3 to enhance the security of SNMPv3 traffic. It include authentication and/or encryption of Management traffic configurable at the operators discretion. ¹
Meshing improvements	The Series 5300XL switches now have improved meshing features. They include greater configuration checks for meshes with (only) Series 5300XL and backwards compatibility mode for reduced connect times with legacy meshing devices. ¹ Note: If you upgrade to release E.07.21 or later from a code version earlier than E.07.21, and if the Series 5300XL switch belongs to a switch mesh domain that includes any HP ProCurve 1600M, 2400M, 2424M, 4000M, or 8000M switches, then you must execute the backward compatibility mode command (mesh backward-compat). Otherwise, the Series 5300XL switch will not connect to the mesh.
OSPF Authentication	Adds MD5 encryption for authenticating OSPF packets. Encryption keys are managed by a centralized Key Management System (KMS). ¹
SSHv2	Updates SSH to support SSHv2. This allows for the use of PEM encoded keys and greater compatibly to SSH client software. ²
SSL	The Series 5300XL Switches now support Secure Socket Layer transactions for Web management access. This allows the switch to authenticate itself to the user and to establish a secure connection. There is support for self-signed and CA signed certificates to allow the administrator to choose the level of security required. ²

Enhancement	Overview
XRRP	The feature used by the HP ProCurve Series 5300XL switches to provide router redundancy or fail-over – a backup router in case one fails. XRRP is similar to the industry standard VRRP (Virtual Router Redundancy Protocol), although the details of the operation are different. ¹
IGMPv3	Adds support for the IGMPv3 Join request. ¹

¹ Refer to the *Management and Configuration Guide for the HP ProCurve Series 5300XL Switches*, Edition 7 — 5990-3016, April 2003 (or later) on the HP ProCurve web site.

² Refer to the *Access Security Guide for the HP ProCurve Series 5300XL Switches*, Edition 3—5990-3031, February 2003 (or later) on the HP ProCurve web site.

Release E.06.10 Enhancements

Adds support for the J4852A HP ProCurve Switch XL 100-FX MTRJ module. Refer to the *HP ProCurve Switch XL Modules Installation Guide* (part number 5990-3069, November 2002).

Release E.06.05, E.06.03, and E.06.02 Enhancements

Software fixes only; no new enhancements.

Release E.06.01 Enhancements

To Locate Publications Supporting E.06.01 (and greater) Features:

1. Go to HP's ProCurve web site at <http://www.hp.com/go/hpprocurve>.
2. Click on **technical support**, then **manuals**.
3. Click on the name of the product for which you want documentation.
4. Select the publication indicated in the enhancement description (below) for the desired feature.

(HP recommends periodically visiting the HP ProCurve web site to keep up-to-date with the latest documentation available for HP ProCurve Series 5300XL switch products.)

Enhancement	Overview
HP J4860A LH-LC Mini-GBIC	New long-haul mini-GBIC support for Series 5300XL switches. ¹
New Flow Control Command	The Series 5300XL switches enable per-port flow control. Beginning with release E.06.0x, use the (global) Flow Control command to enable flow control on the switch, then enable flow control on the desired port(s). ² Note: If you have enabled flow-control on individual ports while using software version E.05.04, but then downloaded software version E.06.01 (or greater) and rebooted the switch, flow control will be disabled globally on the switch (the default) and therefore will not operate on the individual ports previously configured to allow flow control. To resume the configured per-port flow-control activity, you must enable global flow control.

Enhancement	Overview
Change in Default for RIP Redistribution of Connected Routes	Formerly, RIP redistributed both static and connected routes by default. Now, the factory-default RIP operation automatically redistributes connected routes, but not static routes. ²
Change in Default State DHCP-Relay and Helper-Addresses	Changes the factory-default state to now enable DHCP-Relay. You can determine the current state and list Helper addresses. ² Note: With DHCP-Relay disabled, if you upgrade from release E.05.04 to E.06.01 or greater, then reboot the switch, DHCP-Relay becomes enabled. (However, to use DHCP-Relay, you will still need to configure IP Helper addresses.)
Trace Route	Provides a new feature for tracking the path of a packet between the switch and a destination IP address. ²
IP Address Command Change	This change simplifies multinetting on VLANs. ²
802.1x Open VLAN Mode (Authorized-Client and Unauthorized-Client VLANs)	Provides more flexibility for authenticating clients lacking 802.1x supplicant software, and an additional provision for controlling VLAN access by authenticated clients. ³

¹ Refer to the *Switch XL Modules Installation Guide, 5990-3069, November 2002*.

² Refer to the *Management and Configuration Guide for the HP ProCurve Series 5300XL Switches, Edition 7 — 5990-3016, April 2003 (or later)*.

³ Refer to the *Access Security Guide for the HP ProCurve Series 5300XL Switches, Edition 3—5990-3031, February 2003 (or later)*.

Software Fixes in Release E.06.xx and E.07.xx

Release E.05.04 was the first software release for the HP ProCurve Series 5300XL switches.

Release E.07.37

Problems Resolved in Release E.07.34

- **Meshing (PR_96007)** — If a mesh link is broken then shortly followed by the learning of new MAC addresses, the switch may exhibit problems such as bus errors and/or improper communication with other mesh switches.
- **SNMP (PR_96999)** — When the switch is reset (or power-cycled) after configuring an SNMP Community Name with “Operator/Restricted” Rights, it will still allow SNMP sets (writes) to MIB objects.

Release E.07.34

Problems Resolved in Release E.07.34

- **Agent Hang (PR_92802)** — The switch may become unresponsive or hang due to UDP port 1024 broadcast packets never being freed, after the TIMEP and SNTP clients are disabled on the switch.
- **Crash (PR_92659)** — Software exception at memrpt.c:1153 – in 'mInstCtrl', task ID = 0x1455a30
- **IPv6 (PR_93171)** — The switch does not forward IPv6 Router Solicitation/Advertisements when IGMP is enabled.
- **Routing/Agent Performance (PR_95009)** — Routing performance may be degraded due to the aging of host route entries. In this scenario, traffic will be routed through the switch software, thereby resulting in lower performance of routing and agent access (TELNET, SNMP, ping, etc.) operations.
- **VLAN (PR_92466)** — The switch may experience a Bus error related to 802.1X/unauthorized VLAN. The Bus error is similar to:

```
Bus error: HW Addr=0x3861000c IP=0x002df470 Task='mAdMgrCtrl'  
Task ID=0x16e616 0 fp: 0x006a090c sp:0x016e5df0 lr:0x0021d6d8
```

Release E.07.30

Problems Resolved in Release E.07.30

- **Agent Performance (PR_81861)** — The switch may get into a state where end nodes and other network devices cannot contact (ping, telnet, SNMP, etc.) the switch's agent.
- **Routing (PR_90802/91236)** — The switch may route packets out the wrong port due to a mismatch between the source and destination MAC addresses.

Release E.07.29

Problems Resolved in Release E.07.29

- **ACL (No PR)** — The switch allows a user to execute a “no access-list” command for a non-existent ACE without responding with an appropriate error message.
- **ACL (PR_90250)** — Packets that match a “denied” ACL entry may cause the switch’s CPU to run at full utilization.
- **ACL (PR_90415)** — On ACL entries such as “permit/deny tcp any any” the switch will incorrectly permit/deny UDP traffic. The same is inversely true for ACL entries such as “permit/deny udp any any” resulting in TCP traffic being permitted/denied.
- **ACL Performance (PR_90366)** — Addressed potential performance issues of cached TCP and UDP ACL entries.
- **Config (PR_88753)** — A 1000-FDX port setting in the switch config file is not processed properly, resulting in Gigabit-SX ports remaining in an “auto” port configuration. This is most often seen when reloading or TFTP’ing a config file to the switch.
- **Port-sec (PR_88612)** — Static MAC addresses are set up under port security with learn-mode “configure specific” to allow those MAC addresses to communicate through the switch. If one of those MAC addresses is removed via the Web interface of the switch and then re-entered, the owner of that MAC address cannot communicate through the switch.
- **Routing (PR_90554)** — Cached routing information was only updated by IP routable datagrams, and was not being updated by Layer-2 traffic such as ARP.
- **Self Test (PR_90777)** — A self test error may occur when a Gigabit-SX, or LX mini-GBIC module is inserted into the switch while powered on.
- **Spanning Tree (PR_90412)** — Enhancements made to 802.1w operation to address version 3 BPDU communication issues.

Release E.07.27

Problems Resolved in Release E.07.27

- **Enhancement (PR_90365)** — Modifications have been made to the switch meshing code to allow limited mesh interoperability between E.07.x and pre-E.07.x software to allow easier upgrades of all switches in a mesh. (Current implementation does not allow switches running pre-E.07.x software to participate with meshed switches running E.07.x or greater.)
- **IGMP (PR_82491)** — A Group-Specific Query (GSQ) timeout is currently .2 to .6 seconds, rather than the specified default of 1 second.
- **IGMP (PR_90376)** — In some cases, the switch would display “0.0.0.0” for the output of the CLI command “show ip igmp”.
- **Meshing (PR_88689)** — A 12-switch mesh may cause the switch to temporarily run out of packet buffers.
- **Telnet (PR_82522)** — Switch TELNET connections were not closed properly resulting in new TELNET sessions being established which could result in the switch reaching its maximum number (3) of TELNET sessions.
- **Web-Browser Interface (PR_82530)** — A client using Sun java 1.3.X or 1.4.X to access the Web-Browser Interface of the switch, may cause the switch's CPU utilization to increase causing agent processes (such as console, telnet, STP, ping, etc.) to stop functioning.

Release E.07.22

Problems Resolved in Release E.07.22

- **Meshing/Packet Buffer Depletion (PR_88694)** — Certain mesh topologies may cause packet buffers to be depleted on the switch. In this state the switch will generate an "Out of pkt buffers" Event Log message.
- **OSPF (PR_88718)** — In topologies where the switch has redundant routes (via a directly connected link and via an OSPF learned route) to the same network, the switch does not learn the alternate route via OSPF when the directly connected link goes down.
- **Port Hang (Packet Not Forwarded) (PR_88613)** — Under certain traffic load conditions, ports that are toggling on the mini-GBIC module (J4878A) may stop transmitting packets.

Release E.07.21

Problems Resolved in Release E.07.21

- **ARP (PR_5185)** — ARP has been enhanced to have a configurable timeout value, beyond the current default of 20 minutes.
- **CDP (PR_5054)** — CDP multicasts are not passed when CDP is disabled on the switch.
- **CLI (PR_5053)** — Setting the telnet inactivity timeout from the CLI does not indicate a reboot is necessary for changes to take effect.
- **CLI (PR_4984)** — The definition of default gateway following the “ip ?” in the CLI is stated as “Add/delete default route to/from routing tale.”, which is incorrect. Clarified help text for 'ip default-gateway' CLI command to state that this parameter is only used if routing is not enabled on the switch.
- **CLI (PR_5242)** — Information in the command “show boot-history” is not in the order claimed (most recent first).
- **Crash (PR_4621)** — The switch may crash with a message similar to:

```
NMI occurred: IP=0x00317d9c MSR:0x0000b000 LR:0x00013b88  
Task='eDrvPollRx' Task ID=0x1708f20 cr: 0x22000080 sp:0x01708e60 xer:
```
- **Crash (PR_5745)** — The switch may crash with a message similar to:

```
-> Divide by Zero Error: IP=0x801400c0 Task='sal_dpc_hi'  
Task ID=0x80616690 fp:0x00000000 sp:0x80616600 ra:0x800140060  
sr:0x1000af01
```
- **Crash (PR_5635)** — The switch may crash with a message similar to:

```
-> Assertion failed:0, file drvmem.c, line 167
```
- **Crash (PR_5679)** — The switch may crash with a message similar to:

```
-> Bus error: HW Addr=0x00000000 IP=0x00000000 Task='mNSR' Task  
ID=0x1725148 fp: 0x0000c4b0 sp:0x012e9780 lr:0x00330674
```
- **Crash (PR_5712)** — The switch may crash with a message similar to:

```
-> TLB Miss: Virtual Addr=0x00000000 IP=0x8002432c Task='tSmeDebug'
```
- **Crash (PR_5725)** — The switch may crash with a message similar to:

```
-> Assertion failed: nt, file dpc.c, line 169
```
- **Crash (PR_5846)** — WhatsUpGold telnet scan can cause switch to run out of memory and crash with error message similar to:

```
-> malloc_else_fatal() ran out of memory
```

- **Crash (PR_5955)** — The switch may crash with a message similar to:

```
Software exception at alpha_chassis_slot_sm.c:506
```

- **Crash (PR_4986)** — The switch may crash with a message similar to:

```
-> Bus error: HW Addr=0x00ffffff IP=0x332c4530 Task='mSess1' Task  
ID=0x16a62f0 fp: 0x2e2e2e29 sp:0x016a61a0 lr:0x0010f028
```

This crash can occur when eight transceiver modules are installed and the command “interface all” is typed in the configuration context.

- **Crash (PR_5418)** — The switch may crash with a message similar to:

```
-> Software exception at rtsock.c:459 -- in 'tNetTask', task ID =  
0x1a225b0
```

- **Crash (PR_5635)** — The switch may crash with a message similar to:

```
-> Assertion failed:0, file drvmem.c, line 167
```

- **Crash (PR_5341)** — All three of the following steps must occur before the crash is exhibited:

1. A 1000-T port (without a link) is configured as a mirror destination port.
2. Another blade/port traffic is mirrored to that destination port.
3. Mirror destination port/blade will crash or hang after connecting, then disconnecting a 100T link with a message similar to:

```
Software exception at nc_fd_fi.c:693 - in 'mPmSlvCtrl'task ID =  
0x405e9cc8 -> netchip_FIOutboundFlush: Timeout reached!
```

- **Crash (PR_5236)** — The switch may crash with a message similar to:

```
-> AlphaSlaveAddrmgr.p 1021 this time
```

This crash can occur when a module is hot-swapped after downloading new software to the switch without rebooting.

- **Date/Time (PR_5264)** — The timezone can cause the date to wrap if the timezone is set to a valid, but negative value (like -720) without previously configuring the switch's time. The switch may report an invalid year (i.e. 2126).
- **DHCP** — If a client moves without first releasing its IP address, it will not receive a NAK, resulting in the client's inability to get an IP address at its new location.
- **Event Log (PR_5154)** — When a module fails to download, the severity code is INFO instead of WARNING.
- **Fault Finder/CLI (PR_4696)** — Setting fault finder sensitivity always resets action configuration to 'warn', when it should remain 'warn and disable'.

- **FFI/Port Counters (PR_5429)** — No errors are reported by the FFI or port counters when linking at 100 HDX on a Gigabit port with a duplex mismatch.
- **FFI/Port counters (PR_5280)** — FFI and port counters don't have consistent values.
- **Filter (PR_5132)** — Source port Filter on Dyn1 LACP trunk creates Multicast Filter entry that cannot be deleted.
- **Filter (PR_4833)** — Creating a source port filter for a port, moving the port into a trunk, and then reloading the saved TFTP configuration file results in a corrupted download file error.
- **Flow Control (PR_5102)** — Setting a port “X1” in 10-HDX, then attempting to turn on flow control returns an error similar to: “Error setting value fl for port X2”. The error should read “X1”.
- **GVRP (PR_5284)** — Port does not register VLAN even though advertisements are received.
- **Hot-swap (PR_4900)** — Hot-swapping a transceiver logs a message requesting to reboot the switch in order to enable the port, which is not necessary.
- **IGMP (PR_5736)** — If IGMP is turned on for multiple VLANs, and is then turned off for a single VLAN, the Data-Driven Mcast filters for that VLAN are not flushed.
- **IP (PR_5408)** — IP is causing the driver to apply source port filters incorrectly to non-routed packets.
- **IRDP (PR_5923)** — When running the 'rdisc' router discovery tool under Redhat 8.0 or 7.3, Linux reports “ICMP Router Advertise from <IP>: Too short 16 40” when a IRDP packet is received.
- **LACP/Port Security (PR_5059)** — With LACP on, the command “port-sec a l l c action send-alarm” fails with a message similar to “learn-mode: Inconsistent value”.
- **Link Toggle Corruption (PR_5527)** — Addressed issue whereby toggling ports with active, bi-directional traffic could result in corrupted packets within the system.
- **Link-up Polling Interval (PR_5000)** — A delay of up to 1.7 seconds between plugging in a cable (linkbeat established) and traffic being forwarded to and from that port may cause problems with some time sensitive applications. For example, AppleTalk dynamic address negotiation can be affected, resulting in multiple devices using the same AppleTalk address.
- **Menu (PR_5346)** — The one-line help text below the password entry field, displays the message "Enter up to 16 characters (case sensitive), or just press <Enter> to quit". It should read "...sensitive...".
- **Meshing (PR_4969)** — Traffic on oversubscribed mesh links will migrate to other mesh links too slowly.

- **Meshing (PR_4980)** — Meshing does not maintain priority on encapsulated packets that are sent out non-mesh ports.
- **Multicast Filters (PR_4741)** — Any static multicast filters configured once the limit has been reached, would appear in the output of the “show filter” CLI command with only partial information. Switch now correctly returns error message “Unable to add filter” once limit has been reached.
- **OSPF (PR_88611)** — When configured for authentication-key type “simple passwords”, the switch does not include the password in OSPF packets.
- **Port Configuration (PR_5444)** — When interchanging 10/100-TX modules J4862A and J4862B, the port configuration of the module originally installed in the switch is lost.
- **Port counters (PR_5013)** — Hardware port counter filters for dot1dTpPortInDiscards not implemented.
- **Port counters (PR_5171)** — The “Total RX Error” counter is incorrect when the port has heavy 10HDx traffic.
- **Port counters (PR_5204)** — The Runt Rx counter in the detail port counter screen, does not increment when there are fragments.
- **Port counters (PR_5400)** — The 64-bit counter for the highest numbered port on a given module, does not update properly.
- **RADIUS (PR_4886)** — Pressing the tab key gives error message similar to “BAD CHARACTER IN ttyio_line: 0x9n” when entering a username for the radius prompt.
- **RSTP (PR_5449)** — There is a delay in the switch relearning MAC addresses when an RSTP port transitions from Blocking to Forwarding.
- **Self Test (PR_5113)** — There are intermittent port failures reported on HP ProCurve switch xl 100/1000-T modules (J4821A) while performing a packet self test, which was due to the packet test not seeing the very first packet.
- **SNMP (PR_5349)** — The switch does not send SNMP packets larger than 484 bytes.
- **SNTP/TIMEP (PR_5018)** — SNTP still runs when TIMEP is enabled.
- **Source Port Filters (PR_4669)** — Source port filters for illegal ports and trunk port members cannot be deleted from the CLI.
- **Source Port Filters (PR_4719)** — The switch does not automatically remove a source port filter for a trunk that has been deleted.
- **System Information (PR_5169)** — Up Time displayed is not correct.
- **TACACS (PR_5226)** — During TACACS Authentication the TACACS Server's IP address is shown on the switch's 'splash screen'.

- **TCP (PR_5227)** — TCP port 1506 is always open. [Fix is to close TCP port 1506.]
- **TFTP (PR_5034)** — Trying to TFTP a config onto the switch causes the switch to not complete its reload process. The switch hangs and does not come up.
- **VLANs (PR_4405)** — The VIDs of deleted VLANs are not removed from the switch's VLAN table, causing the switch to not allow new VLANs to be created (once the VID table is full).
- **Web (PR_5455)** — Bad URL was being mirrored back to the user following Nessus script attack test.
- **Web-Browser Interface (PR_5199)** — Having a ProCurve switch 4100gl series as a commander, and a ProCurve switch 4000m as a member of the stack, the stack commander was not checking security when doing passthrough.
- **Web-Browser Interface (PR_5052)** — The CLI does not disable the web-browser interface.
- **Web-Browser Interface (PR_5055)** — Missing firmware/ROM information in Web UI.
- **Web-Browser Interface (PR_5158)** — When clicking on the Web UI System Info “Apply Changes” button, a character appears under the “VLAN Configuration” tab.
- **Web-Browser Interface (PR_4976)** — Mis-spelled word on the product registration screen of the WEB UI. The phrase “...does not appears above...” is now “...does not appear above...”
- **Web-Browser Interface (PR_4996)** — When using a ProCurve Switch 4108 as a commander switch in the stack, a ProCurve Switch 2424M is not shown in the device view of the stack closeup in the web UI. The message “Device view, HP2424M, not supported by firmware of commander” is present instead of the device view.
- **Web-Browser Interface (PR_4904)** — When a transceiver is removed from the switch, its configuration is not cleared on the Status->port status screen of the web UI. The transceiver type will still show until a new transceiver is inserted.
- **Web-browser Interface (PR_4235)** — Web-browser port utilization label does not display the bandwidth number. Shows x% of 0Mb instead of x% of 100Mb or x% of 1Gb.
- **Web-Browser Interface (PR_4495)** — Administrator password can be used in combination with the operator username.

Release E.06.10

Problems Resolved in Release E.06.10

- **Crash (PR_5229)** — Greater than 100 hotswaps causes mesg buff crash.
- **Flow Control (PR_5215)** — Enabling Flow Control on a port does not enable Global Flow Control on the switch.

- **Security (PR_5226)** — Removed display of TACACS Server IP address during remote management logon.
- **Security (PR_5227)** — TCP Port 1506 access is closed when Telnet or Stacking is disabled.
- **Web-browser interface (PR_5052)** — Executing the CLI command “no web-management” does not disable access to the web-browser interface.

Release E.06.05

Problems Resolved in Release E.06.05

- **Crash (PR_5471)** — The CLI command “show ip ospf neighbor” may cause the switch to crash with a message similar to:

```
Bus error: HW Addr=0x30008fa0 IP=0x001112a4 Task='mSess1' Task  
ID=0x169b110
```

Release E.06.03

Problems Resolved in Release E.06.03

- **Packets not Forwarded (PR_5201)** — A synchronization issue between the switch chassis and modules after several weeks of continuous operation can result in packets being dropped by the switch instead of being forwarded.

Release E.06.02

Problems Resolved in Release E.06.02

- **Performance (PR_5161)** — Certain high traffic levels may cause the switch to drop packets.

Release E.06.01

Problems Resolved in Release E.06.01

- **100/1000-T module (PR_4956)** — Bringing a port up and down while the port is running at or near maximum throughput may cause the module to reset.
- **802.1x (PR_4972)** — Support for 802.1x is not implemented in routing mode.
- **802.1x (PR_5043)** — When changing an 802.1x port configuration, the switch does not correctly restore default VLAN ID after disconnecting the port.
- **ARP (PR_4443)** — Switch incorrectly replied to an ARP packet with a header length ranging from 7 to 15 bytes. The switch now replies only if header length is equal to 6 bytes.
- **CDP (PR_4546)** — CDP multicast packets are not passed through the switch when CDP is disabled on the switch.

- **CLI/RIP (PR_5046)** — The CLI command 'show ip rip interface' results in the following:
"RIP interface information for 0.0.0.0, RIP is not configured on this..."
- **CoS (PR_4738)** — Cannot configure CoS on a trunk port. Also, enhancements to CoS error handling when moving ports in and out of a trunk.
- **CoS (PR_4982)** — The output of the CLI command “show qos port-priority” may show an illegal state (“no priority”) for the Differentiated Services Codepoint (DSCP) policy. This problem may occur given this situation:
 1. Configure a DSCP policy on a port, and
 2. Remove module, and
 3. Reboot switch, and
 4. Delete DSCP policy, and
 5. Hot-swap module back into the switch
- **Crash (PR_4933)** — Switch may crash while hot swapping a module with a message similar to:
-> Software exception in ISR@alloc_free.c:479
- **DHCP-Relay (PR_4551)** — Configuring an IP helper address on a VLAN does not automatically turn on the DHCP-relay function.
- **Extended RMON (PR_5083)** — When Extended RMON and Routing are enabled, the switch may duplicate packets on the network.
- **LACP (PR_5000)** — Link-up polling interval: A delay of up to 1.7 seconds between plugging in a cable (linkbeat established) and traffic being forwarded to and from that port may cause problems with some time sensitive applications. For example, AppleTalk dynamic address negotiation can be affected, resulting in multiple devices using the same AppleTalk address.
- **Mini-GBIC Link Connectivity Issue (PR_4957)** — A mini-GBIC Gigabit-SX/LX link between an HP ProCurve Switch 5300XL and an HP ProCurve Routing Switch 9300 may not be established when both sides are in the default configuration (Auto).
- **Radius (PR_4886)** — If using the TAB key while entering a username for the radius prompt, the switch may display an error message similar to:
->BAD CHARACTER IN ttyio_line: 0x9n
- **RIP (PR_4757)** — After the switch reboots and if a routing loop (3 or more routers) exists in the topology, RIP may age out its own connected routes (even though the routes are still valid).
- **RIP (PR_4965)** — Static routes are redistributed into RIP. [Fix: Static routes are no longer redistributed into RIP by default, only directly connected routes are redistributed.] [Old description: Changes to RIP route redistribution such that only connected routes are redistributed, not static configured routes.

- **RIP (PR_4987)** — If multiple IP addresses are configured for a VLAN and RIP is running on one or more of the secondary addresses, the CLI command “show ip rip vlan x” will only show information about the primary IP address.
- **Routing (PR_4977)** — If a default route is not configured and the switch receives a Layer 3 packet with an unknown source address, the packet will be routed by software even though an entry for the destination exists in the hardware routing table.
- **Static Routes (PR_5040)** — Reject static routes could not be created.
- **Web Browser Interface (PR_4976)** — The product Registration screen contains a typographical error. The phrase “...does not appears above...” is now “...does not appear above...”.



© 2001, 2003 Hewlett-Packard Development Company, LP. The information contained herein is subject to change without notice.

Edition 3, October 2003
Manual Part Number
5990-6004
