

access security guide



hp procurve
series 4100gl switches

www.hp.com/go/hpprocurve



HP Procurve Series 4100GL Switches

Software Release G.05.02 or Greater

Access Security Guide

© Copyright 2001-2002 Hewlett-Packard Company
All Rights Reserved.

This document contains information which is protected by copyright. Reproduction, adaptation, or translation without prior permission is prohibited, except as allowed under the copyright laws.

Publication Number

5990-3032
April 2002
Edition 1

Applicable Product

HP Procurve Switch 4104GL (J4887A)
HP Procurve Switch 4108GL (J4865A)

Trademark Credits

Microsoft, Windows, Windows 95, and Microsoft Windows NT are registered trademarks of Microsoft Corporation. Internet Explorer is a trademark of Microsoft Corporation. Ethernet is a registered trademark of Xerox Corporation. Netscape is a registered trademark of Netscape Corporation. Cisco® is a trademark of Cisco Systems, Inc.

Disclaimer

The information contained in this document is subject to change without notice.

HEWLETT-PACKARD COMPANY MAKES NO WARRANTY OF ANY KIND WITH REGARD TO THIS MATERIAL, INCLUDING, BUT NOT LIMITED TO, THE IMPLIED WARRANTIES OF MERCHANTABILITY AND FITNESS FOR A PARTICULAR PURPOSE. Hewlett-Packard shall not be liable for errors contained herein or for incidental or consequential damages in connection with the furnishing, performance, or use of this material.

Hewlett-Packard assumes no responsibility for the use or reliability of its software on equipment that is not furnished by Hewlett-Packard.

Warranty

See the Customer Support/Warranty booklet included with the product.

A copy of the specific warranty terms applicable to your Hewlett-Packard products and replacement parts can be obtained from your HP Sales and Service Office or authorized dealer.

Contents

Getting Started

Contents	ix
Introduction	x
Overview of Access Security Features	x
Command Syntax Conventions	xi
Simulating Display Output	xii
Command Prompts	xii
Screen Simulations	xii
Related Publications	xiii
Getting Documentation From the Web	xv
Sources for More Information	xvi
Need Only a Quick Start?	xvii

1 Configuring Username and Password Security

Contents	1-1
Overview	1-2
Configuring Local Password Security	1-4
Menu: Setting Passwords	1-4
CLI: Setting Passwords and Usernames	1-5
Web: Setting Passwords and Usernames	1-6

2 TACACS+ Authentication

Contents	2-1
Overview	2-2
Terminology Used in TACACS Applications:	2-4
General System Requirements	2-5
General Authentication Setup Procedure	2-6
Configuring TACACS+ on the Switch	2-9
Before You Begin	2-9
CLI Commands Described in this Section	2-9

Viewing the Switch's Current Authentication Configuration	2-10
Viewing the Switch's Current TACACS+ Server Contact Configuration	2-10
Configuring the Switch's Authentication Methods	2-11
Configuring the Switch's TACACS+ Server Access	2-15
How Authentication Operates	2-20
General Authentication Process Using a TACACS+ Server	2-20
Local Authentication Process	2-22
Using the Encryption Key	2-23
General Operation	2-23
Encryption Options in the Switch	2-23
Controlling Web Browser Interface Access When Using TACACS+ Authentication	2-24
Messages Related to TACACS+ Operation	2-25
Operating Notes	2-25
3 RADIUS Authentication and Accounting	
Contents	3-1
Overview	3-2
Terminology	3-3
Switch Operating Rules for RADIUS	3-4
General RADIUS Setup Procedure	3-5
Configuring the Switch for RADIUS Authentication	3-6
Outline of the Steps for Configuring RADIUS Authentication	3-6
1. Configure Authentication for the Access Methods You Want RADIUS To Protect	3-8
2. Configure the Switch To Access a RADIUS Server	3-10
3. Configure the Switch's Global RADIUS Parameters	3-12
Local Authentication Process	3-14
Controlling Web Browser Interface Access When Using RADIUS Authentication	3-15

Configuring RADIUS Accounting	3-16
Operating Rules for RADIUS Accounting	3-17
Steps for Configuring RADIUS Accounting	3-18
1. Configure the Switch To Access a RADIUS Server	3-19
2. Configure Accounting Types and the Controls for Sending Reports to the RADIUS Server	3-20
3. (Optional) Configure Session Blocking and Interim Updating Options	3-22
Viewing RADIUS Statistics	3-23
General RADIUS Statistics	3-23
RADIUS Authentication Statistics	3-25
RADIUS Accounting Statistics	3-26
Changing RADIUS-Server Access Order	3-27
Messages Related to RADIUS Operation	3-29
4 Configuring Secure Shell (SSH)	
Contents	4-1
Overview	4-2
Terminology	4-4
Prerequisite for Using SSH	4-5
Public Key Format Requirement	4-5
Steps for Configuring and Using SSH for Switch and Client Authentication	4-6
General Operating Rules and Notes	4-8
Configuring the Switch for SSH Operation	4-9
1. Assigning a Local Login (Operator) and Enable (Manager) Password	4-9
2. Generating the Switch's Public and Private Key Pair	4-10
3. Providing the Switch's Public Key to Clients	4-12
4. Enabling SSH on the Switch and Anticipating SSH Client Contact Behavior	4-15
5. Configuring the Switch for SSH Authentication	4-18
6. Use an SSH Client To Access the Switch	4-21

Further Information on SSH Client Public-Key Authentication	4-21
Messages Related to SSH Operation	4-26
5 Configuring Port-Based Access Control (802.1x)	
Overview	5-1
Why Use Port-Based Access Control?	5-1
General Features	5-1
How 802.1x Operates	5-3
Authenticator Operation	5-3
Switch-Port Supplicant Operation	5-4
Terminology	5-5
General Operating Rules and Notes	5-6
General Setup Procedure for Port-Based Access Control (802.1x)	5-7
Before You Begin	5-7
Overview: Configuring 802.1x Authentication on the Switch	5-8
Configuring Switch Ports as 802.1x Authenticators	5-9
1. Disable LACP on the Ports Selected for 802.1x Access	5-10
2. Enable 802.1x Authentication on Selected Ports	5-10
3. Configure the 802.1x Authentication Method	5-12
4. Enter the RADIUS Host IP Address(es)	5-13
5. Optional: For Authenticator Ports, Configure Port-Security To Allow Only 802.1x Devices	5-14
6. Enable 802.1x Authentication on the Switch	5-15
Configuring Switch Ports To Operate As Supplicants for 802.1x Connections to Other Switches	5-16
Displaying 802.1x Configuration, Statistics, and Counters	5-20
Show Commands for Port-Access Authenticator	5-20
Show Commands for Port-Access Supplicant	5-22
How 802.1x Authentication Affects VLAN Operation	5-23
Messages Related to 802.1x Operation	5-27

6 Configuring and Monitoring Port Security

Contents	6-1
Overview	6-2
Basic Operation	6-2
Blocking Unauthorized Traffic	6-3
Trunk Group Exclusion	6-4
Planning Port Security	6-5
Port Security Command Options and Operation	6-6
Retention of Static Addresses	6-8
Displaying Current Port Security Settings	6-9
Configuring Port Security	6-10
Web: Displaying and Configuring Port Security Features	6-15
Reading Intrusion Alerts and Resetting Alert Flags	6-15
Notice of Security Violations	6-15
How the Intrusion Log Operates	6-16
Keeping the Intrusion Log Current by Resetting Alert Flags	6-17
Menu: Checking for Intrusions, Listing Intrusion Alerts, and Resetting Alert Flags	6-17
CLI: Checking for Intrusions, Listing Intrusion Alerts, and Resetting Alert Flags	6-19
Using the Event Log To Find Intrusion Alerts	6-21
Web: Checking for Intrusions, Listing Intrusion Alerts, and Resetting Alert Flags	6-22
Operating Notes for Port Security	6-22

7 Using Authorized IP Managers

Contents	7-1
Overview	7-2
Options	7-3
Access Levels	7-3
Defining Authorized Management Stations	7-4
Overview of IP Mask Operation	7-4
Menu: Viewing and Configuring IP Authorized Managers	7-5

Contents

CLI: Viewing and Configuring Authorized IP Managers	7-6
Listing the Switch's Current Authorized IP Manager(s)	7-6
Configuring IP Authorized Managers for the Switch	7-7
Web: Configuring IP Authorized Managers	7-8
Building IP Masks	7-9
Configuring One Station Per Authorized Manager IP Entry	7-9
Configuring Multiple Stations Per Authorized Manager IP Entry . . .	7-10
Additional Examples for Authorizing Multiple Stations	7-12
Operating Notes	7-12

Getting Started

Contents

Introduction	x
Overview of Access Security Features	x
Command Syntax Conventions	xi
Simulating Display Output	xii
Command Prompts	xii
Screen Simulations	xii
Related Publications	xiii
Getting Documentation From the Web	xv
Sources for More Information	xvi
Need Only a Quick Start?	xvii

Introduction

This *Access Security Guide* is intended for use with the following switches:

- HP Procurve Switch 4104GL
- HP Procurve Switch 4108GL

Together, these two devices are termed the *HP Procurve Series 4100GL Switches*.

Overview of Access Security Features

- Local Manager and Operator passwords (page 1-1)
Control access and privileges for the CLI, menu, and web browser interface.
- TACACS+ Authentication (page 2-1)
Uses an authentication application on a central server to allow or deny access to Series 4100GL switch.
- RADIUS Authentication and Accounting (page 3-1)
Like TACACS+, uses an authentication application on a central server to allow or deny access to Series 4100GL switch. RADIUS also provides accounting services for sending data about user activity and system events to a RADIUS server.
- Secure Shell (SSH) Authentication (page 4-1)
Provides encrypted paths for remote access to switch management functions.
- Port-Based Access Control (802.1x) (page 5-1)
On point-to-point connections, enables the switch to allow or deny traffic between a port and an 802.1x-aware device (supplicant) attempting to access the switch. Also enables the switch to operate as a supplicant for connections to other 802.1x-aware switches.
- Port Security (page 6-1)
Enables a switch port to maintain a unique list of MAC addresses defining which specific devices are allowed to access the network through that port. Also enables a port to detect, prevent, and log access attempts by unauthorized devices.
- Authorized IP Managers (page 7-1)
Allows access to the switch by a networked device having an IP address previously configured in the switch as "authorized".

HP recommends that you use local passwords together with the switch's other security features to provide a more comprehensive security fabric than if you use only the local password option. Table 1 lists these features with the security coverage they provide.

Table 1. Management Access Security Protection

Security Feature	Offers Protection Against Unauthorized Client Access to Switch Management Features					Offers Protection Against Unauthorized Client Access to the Network
	Connection	Telnet	SNMP (Net Mgmt)	Web Browser	SSH Client	
Local Manager and Operator Usernames and Passwords*	PtP:	Yes	No	Yes	Yes	No
	Remote:	Yes	No	Yes	Yes	No
TACACS+*	PtP:	Yes	No	No	Yes	No
	Remote:	Yes	No	No	Yes	No
RADIUS*	PtP:	Yes	No	No	Yes	No
	Remote:	Yes	No	No	Yes	No
SSH	PtP:	Yes	No	No	Yes	No
	Remote:	Yes	No	No	Yes	No
Port-Based Access Control (802.1x)	PtP:	Yes	Yes	Yes	Yes	Yes
	Remote:	No	No	No	No	No
Port Security (MAC address)	PtP:	Yes	Yes	Yes	Yes	Yes
	Remote:	Yes	Yes	Yes	Yes	Yes
Authorized IP Managers	PtP:	Yes	Yes	Yes	Yes	No
	Remote:	Yes	Yes	Yes	Yes	No

*Protection for serial port access includes the local Manager/Operator, TACACS+, and RADIUS options (direct connect or modem access).

There are two security areas to protect: access to the switch management features and access to the network through the switch. The above table shows the type of protection each switch security feature offers.

The *Product Documentation CD-ROM* shipped with the switch includes a copy of this guide. You can also download the latest copy from the HP Procurve website. (Refer to “Getting Documentation From the Web”, below.)

Command Syntax Conventions

This guide uses the following conventions for command syntax and displays.

Syntax: aaa port-access authenticator < *port-list* >
 [control < authorized | auto | unauthorized >]

- Vertical bars (|) separate alternative, mutually exclusive elements.
- Square brackets ([]) indicate optional elements.
- Braces (< >) enclose required elements.
- Braces within square brackets ([< >]) indicate a required element within an optional choice.
- Boldface indicates use of a CLI command, part of a CLI command syntax, or other displayed element in general text. For example:

 “Use the **copy tftp** command to download the key from a TFTP server.”

- Italics indicate variables for which you must supply a value when executing the command. For example, in this command syntax, you must provide one or more port numbers:

Syntax: aaa port-access authenticator < *port-list* >

Simulating Display Output

Commands or command output positioned to simulate displays of switch information in a computer screen are printed in a monospace font.

Command Prompts

In the default configuration, your Series 4100GL switch displays one of the following CLI prompts:

```
HP Procurve Switch 4104#  
HP Procurve Switch 4108#
```

To simplify recognition, this guide uses HPswitch to represent command prompts for all models. That is:

```
HPswitch#
```

(You can use the **hostname** command to change the text in the CLI prompt.)

Screen Simulations

Figures containing simulated screen text and command output look like this:

```
HPswitch> show version
Image stamp:   /sw/code/build/info
               June 1 2002 13:43:13
               G.05.02
               139
HPswitch>
```

Figure 1. Example of a Figure Showing a Simulated Screen

In some cases, brief command-output sequences appear without figure identification. For example:

```
HPswitch(config)# clear public-key
HPswitch(config)# show ip client-public-key
show_client_public_key: cannot stat keyfile
```

Related Publications

Product Notes and Software Update Information. The *Read Me First* shipped with your switch provides software update information, product notes, and other information. A printed copy is shipped with your switch. For the latest version, refer to “Getting Documentation From the Web” on page xv.

Physical Installation and Initial Network Access. Use the *Installation and Getting Started Guide* shipped with your switch to prepare for and perform the physical installation. This guide also steps you through connecting the switch to your network and assigning IP addressing, as well as describing the LED indications for correct operation and trouble analysis. A PDF version of this guide is also provided on the *Product Documentation CD-ROM* shipped with the switch. And you can download a copy from the HP Procurve website. (See “Getting Documentation From the Web” on page xv.)

General Switch Management and Configuration. Use the *Management and Configuration Guide* for information on:

- Using the command line interface (CLI), Menu interface, and web browser interface
- Learning the operation and configuration of all switch software features other than the access security features included in this guide
- Troubleshooting software operation

HP provides a PDF version of this guide on the *Product Documentation CD-ROM* shipped with the switch. You can also download the latest copy from the HP Procurve website. (See “Getting Documentation From the Web” on page xv.)

Command Line Interface Reference Guide. This guide, available in a PDF file on the HP Procurve website, provides a summary of the CLI commands generally available for HP Procurve switches. For the latest version, see “Getting Documentation From the Web” on page xv.

Release Notes. Release notes are posted on the HP Procurve website and provide information on new software updates:

- New features and how to configure and use them
- Software management, including downloading software to the switch
- Software fixes addressed in current and previous releases

To view and download a copy of the latest release notes for your switch, see “Getting Documentation From the Web” on page xv.

Getting Documentation From the Web

1. Go to the HP Procurve website at <http://www.hp.com/go/hpprocurve>
2. Click on **technical support**.
3. Click on **manuals**.
4. Click on the product for which you want to view or download a manual.

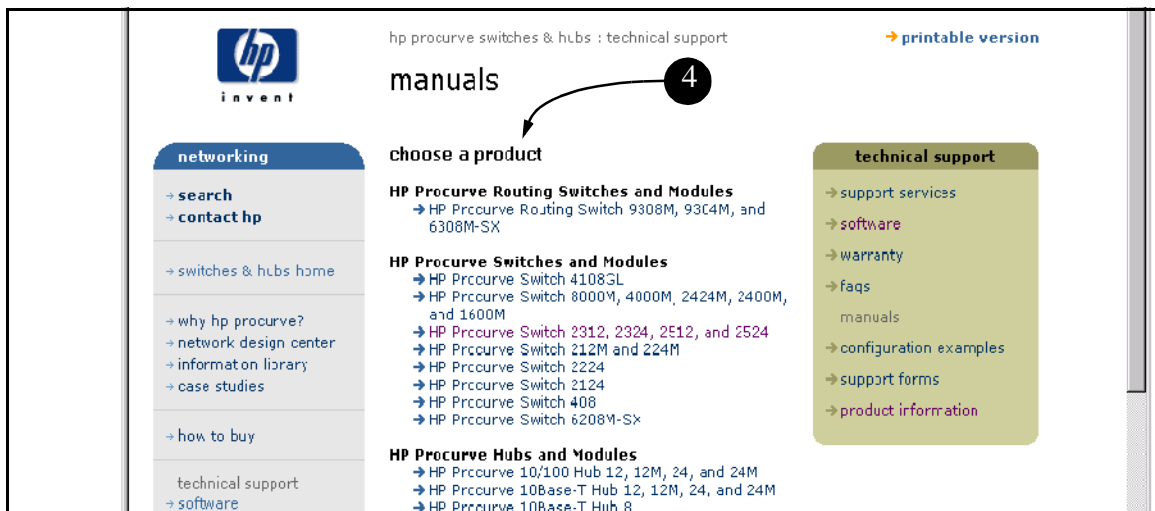
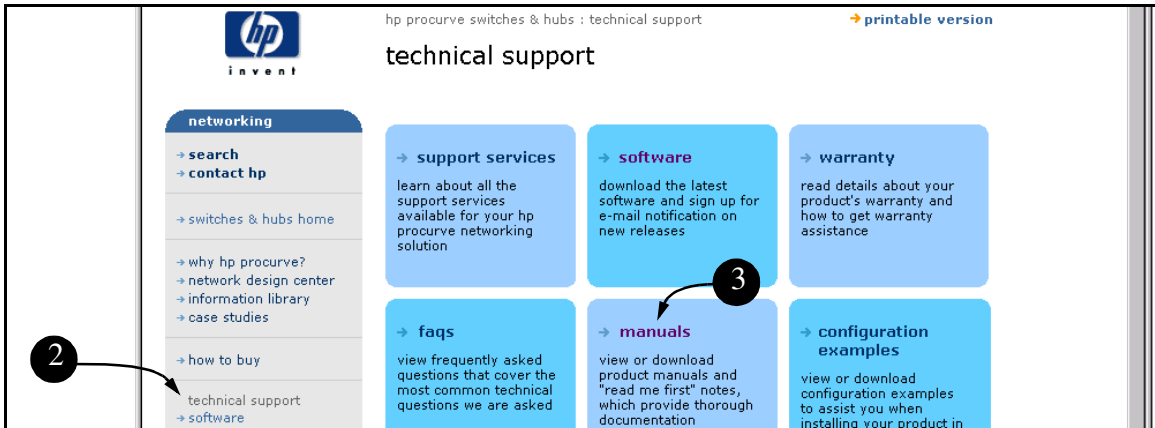

Sources for More Information

- If you need information on specific parameters in the menu interface, refer to the online help provided in the interface.

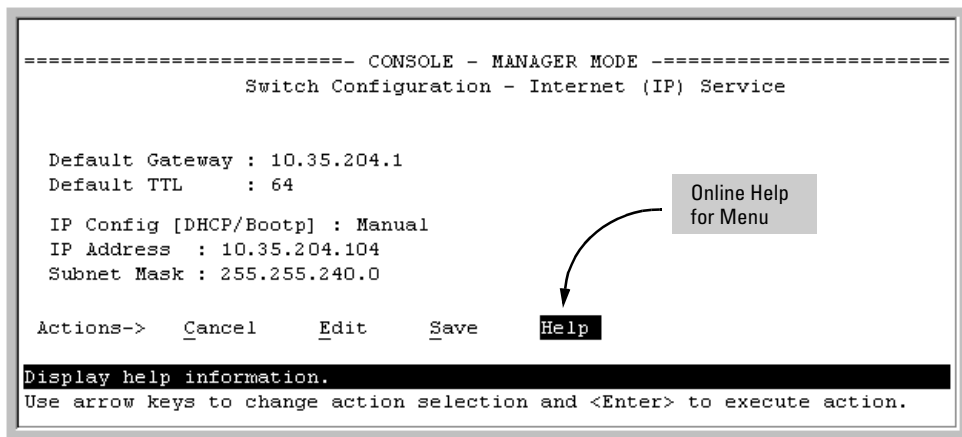

- If you need information on a specific command in the CLI, type the command name followed by "help". For example:

```
HPswitch# write help
Usage: write <memory|terminal>

Description: View or save the running configuration of the switch.

        write terminal - displays the running configuration of the
                        switch on the terminal
        write memory   - saves the running configuration of the
                        switch to flash. The saved configuration
                        becomes the boot-up configuration of the switch
                        the next time it is booted.
```

- If you need information on specific features in the HP Web Browser Interface (hereafter referred to as the "web browser interface"), use the online help available for the web browser interface. For more information on web browser Help options, refer to the *Management and Configuration Guide* for your switch.
- If you need further information on Hewlett-Packard switch technology, visit the HP Procurve website at:

<http://www.hp.com/go/hpprocurve>

Need Only a Quick Start?

IP Addressing. If you just want to give the switch an IP address so that it can communicate on your network, or if you are not using VLANs, HP recommends that you use the Switch Setup screen to quickly configure IP addressing. To do so, do one of the following:

- Enter **setup** at the CLI Manager level prompt.

```
HPswitch# setup
```
- In the Main Menu of the Menu interface, select
8. Run Setup

For more on using the Switch Setup screen, see the *Installation and Getting Started Guide* you received with the switch.

To Set Up and Install the Switch in Your Network

Use the *HP Procurve Series 4100GL Installation and Getting Started Guide* (shipped with the switch) for the following:

- Notes, cautions, and warnings related to installing and using the switch and its related modules
- Instructions for physically installing the switch in your network
- Quickly assigning an IP address and subnet mask, set a Manager password, and (optionally) configure other basic features.

Getting Started
Need Only a Quick Start?

Configuring Username and Password Security

Contents

Overview	1-2
Configuring Local Password Security	1-4
Menu: Setting Passwords	1-4
CLI: Setting Passwords and Usernames	1-5
Web: Setting Passwords and Usernames	1-6

Overview

Feature	Default	Menu	CLI	Web
Set Usernames	no user names set	—	—	page 1-6
Set a Password	no passwords set	page 1-4	page 1-5	page 1-6
Delete Password Protection	n/a	page 1-4	page 1-6	page 1-6

Console access includes both the menu interface and the CLI. There are two levels of console access: Manager and Operator. For security, you can set a *password pair* (username and password) on each of these levels.

Note

Usernames are optional. Also, in the menu interface, you can configure passwords, but not usernames. To configure usernames, use the CLI or the web browser interface.

Level	Actions Permitted
Manager:	Access to all console interface areas. <i>This is the default level.</i> That is, if a Manager password has <i>not</i> been set prior to starting the current console session, then anyone having access to the console can access any area of the console interface.
Operator:	Access to the Status and Counters menu, the Event Log, and the CLI*, but no Configuration capabilities. On the Operator level, the configuration menus, Download OS, and Reboot Switch options in the Main Menu are not available.

*Allows use of the ping, link-test, show, menu, exit, and logout commands, plus the enable command if you can provide the Manager password.

To configure password security:

1. Set a Manager password pair (and an Operator password pair, if applicable for your system).
2. Exit from the current console session. A Manager password pair will now be needed for full access to the console.

If you do steps 1 and 2, above, then the next time a console session is started for either the menu interface or the CLI, a prompt appears for a password. Assuming you have protected both the Manager and Operator levels, the level of access to the console interface will be determined by which password is entered in response to the prompt.

If you set a Manager password, you may also want to configure the **Inactivity Time** parameter. (Refer to the *Management and Configuration Guide* for your switch.) This causes the console session to end after the specified period of inactivity, thus giving you added security against unauthorized console access.

Note

The manager and operator passwords and (optional) usernames control access to the menu interface, CLI, and web browser interface.

If you configure only a Manager password (with no Operator password), and in a later session the Manager password is not entered correctly in response to a prompt from the switch, then the switch does not allow management access for that session.

If the switch has a password for both the Manager and Operator levels, and neither is entered correctly in response to the switch's password prompt, then the switch does not allow management access for that session.

Passwords are case-sensitive.

Caution

If the switch has neither a Manager nor an Operator password, anyone having access to the switch through either Telnet, the serial port, or the web browser interface can access the switch with full manager privileges. Also, if you configure only an Operator password, entering the Operator password enables full manager privileges.

The rest of this section covers how to:

- Set passwords
- Delete passwords
- Recover from a lost password

Configuring Local Password Security

Menu: Setting Passwords

As noted earlier in this section, usernames are optional. Configuring a username requires either the CLI or the web browser interface.

1. From the Main Menu select:

3. Console Passwords

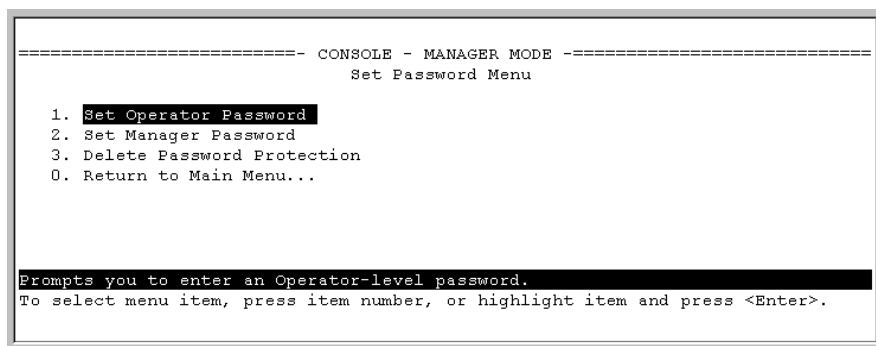

```
----- CONSOLE - MANAGER MODE -----  
Set Password Menu  
  
1. Set Operator Password  
2. Set Manager Password  
3. Delete Password Protection  
0. Return to Main Menu...  
  
Prompts you to enter an Operator-level password.  
To select menu item, press item number, or highlight item and press <Enter>.
```

Figure 1-1. The Set Password Screen

2. To set a new password:
 - a. Select **Set Manager Password** or **Set Operator Password**. You will then be prompted with **Enter new password**.
 - b. Type a password of up to 16 ASCII characters with no spaces and press **[Enter]**. (Remember that passwords are case-sensitive.)
 - c. When prompted with **Enter new password again**, retype the new password and press **[Enter]**.

After you configure a password, if you subsequently start a new console session, you will be prompted to enter the password. (If you use the CLI or web browser interface to configure an optional username, the switch will prompt you for the username, and then the password.)

To Delete Password Protection (Including Recovery from a Lost Password): This procedure deletes *all* usernames (if configured) and passwords (Manager and Operator).

If you have physical access to the switch, press and hold the Clear button (on the front of the switch) for a minimum of one second to clear all password protection, then enter new passwords as described earlier in this chapter.

If you do not have physical access to the switch, you will need Manager-Level access:

1. Enter the console at the Manager level.
2. Go to the **Set Passwords** screen as described above.
3. Select **Delete Password Protection**. You will then see the following prompt:

Continue Deletion of password protection? No

4. Press the Space bar to select **Yes**, then press `[Enter]`.
5. Press `[Enter]` to clear the Password Protection message.

To Recover from a Lost Manager Password: If you cannot start a console session at the Manager level because of a lost Manager password, you can clear the password by getting physical access to the switch and pressing and holding the Clear button for a minimum of one second. This action deletes all passwords and usernames (Manager and Operator) used by both the console and the web browser interface.

CLI: Setting Passwords and Usernames

Commands Used in This Section

password	See below.
----------	------------

Configuring Manager and Operator Passwords.

Syntax: [no] password <manager | operator > [user-name ASCII-STR]
[no] password < all >

```
HPswitch(config)# password manager
New password: *****
Please retype new password: *****
HPswitch(config)# password operator
New password: *****
Please retype new password: *****
```

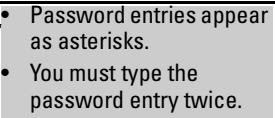

Figure 1-2. Example of Configuring Manager and Operator Passwords

To Remove Password Protection. Removing password protection means to eliminate password security. This command prompts you to verify that you want to remove one or both passwords, then clears the indicated password(s). (This command also clears the username associated with a password you are removing.) For example, to remove the Operator password (and username, if assigned) from the switch, you would do the following:

```
HPswitch(config)# no password
Password protection will be deleted, do you want to continue [y/n]? y
HPswitch(config)#
```

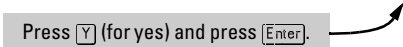

Figure 1-3. Removing a Password and Associated Username from the Switch

The effect of executing the command in figure 1-3 is to remove password protection from the Operator level. (This means that anyone who can access the switch console can gain Operator access without having to enter a username or password.)

Web: Setting Passwords and Usernames

In the web browser interface you can enter passwords and (optional) usernames.

To Configure (or Remove) Usernames and Passwords in the Web Browser Interface.

1. Click on the **Security** tab.

Click on **Device Passwords**.

2. Do one of the following:
 - To set username and password protection, enter the usernames and passwords you want in the appropriate fields.
 - To remove username and password protection, leave the fields blank.
3. Implement the usernames and passwords by clicking on **Apply Changes**.

To access the web-based help provided for the switch, click on **?** in the web browser screen.

TACACS+ Authentication

Contents

Overview	2-2
Terminology Used in TACACS Applications:	2-4
General System Requirements	2-5
General Authentication Setup Procedure	2-6
Configuring TACACS+ on the Switch	2-9
Before You Begin	2-9
CLI Commands Described in this Section	2-9
Viewing the Switch's Current Authentication Configuration	2-10
Viewing the Switch's Current TACACS+ Server Contact Configuration	2-10
Configuring the Switch's Authentication Methods	2-11
Configuring the Switch's TACACS+ Server Access	2-15
How Authentication Operates	2-20
General Authentication Process Using a TACACS+ Server	2-20
Local Authentication Process	2-22
Using the Encryption Key	2-23
General Operation	2-23
Encryption Options in the Switch	2-23
Controlling Web Browser Interface Access When Using TACACS+ Authentication	2-24
Messages	2-25
Operating Notes	2-25

Overview

Feature	Default	Menu	CLI	Web
view the switch's authentication configuration	n/a	—	page 2-10	—
view the switch's TACACS+ server contact configuration	n/a	—	page 2-10	—
configure the switch's authentication methods	disabled	—	page 2-11	—
configure the switch to contact TACACS+ server(s)	disabled	—	page 2-15	—

TACACS+ authentication enables you to use a central server to allow or deny access to the Series 4100GL switches (and other TACACS-aware devices) in your network. This means that you can use a central database to create multiple unique username/password sets with associated privilege levels for use by individuals who have reason to access the switch from either the switch's console port (local access) or Telnet (remote access).

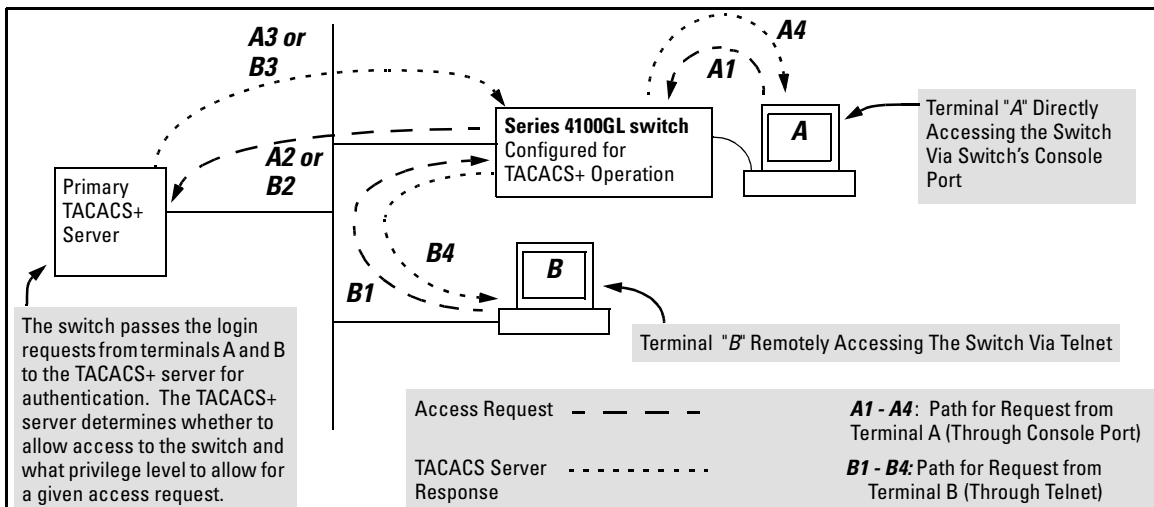

Figure 2-1. Example of TACACS+ Operation

TACACS+ in the Series 4100GL switches manages authentication of logon attempts through either the Console port or Telnet. TACACS+ uses an authentication hierarchy consisting of (1) remote passwords assigned in a TACACS+

server and (2) local passwords configured on the switch. That is, with TACACS+ configured, the switch first tries to contact a designated TACACS+ server for authentication services. If the switch fails to connect to any TACACS+ server, it defaults to its own locally assigned passwords for authentication control if it has been configured to do so. For both Console and Telnet access you can configure a login (read-only) and an enable (read/write) privilege level access.

**Notes Regarding
Software
Release G.05.xx**

Software release G.05.xx (or greater) for the Series 4100GL switches enables TACACS+ authentication, which allows or denies access to a Series 4100GL switches on the basis of correct username/password pairs managed by the TACACS+ server, and to specify the privilege level to allow if access is granted. This release does not support TACACS+ authorization or accounting services.

In release G.05.xx, TACACS+ does not affect web browser interface access. See "Controlling Web Browser Interface Access" on page 2-24.

Terminology Used in TACACS Applications:

- **NAS (Network Access Server):** This is an industry term for a TACACS-aware device that communicates with a TACACS server for authentication services. Some other terms you may see in literature describing TACACS operation are *communication server*, *remote access server*, or *terminal server*. These terms apply to a Series 4100GL switches when TACACS+ is enabled on the switch (that is, when the switch is TACACS-aware).
- **TACACS+ Server:** The server or management station configured as an access control server for TACACS-enabled devices. To use TACACS+ with the Series 4100GL switches and any other TACACS-capable devices in your network, you must purchase, install, and configure a TACACS+ server application on a networked server or management station in the network. The TACACS+ server application you install will provide various options for access control and access notifications. For more on the TACACS+ services available to you, see the documentation provided with the TACACS+ server application you will use.
- **Authentication:** The process for granting user access to a device through entry of a user name and password and comparison of this username/password pair with previously stored username/password data. Authentication also grants levels of access, depending on the privileges assigned to a user name and password pair by a system administrator.
 - **Local Authentication:** This method uses username/password pairs configured locally on the switch; one pair each for manager-level and operator-level access to the switch. You can assign local usernames and passwords through the CLI or web browser interface. (Using the menu interface you can assign a local password, but not a username.) Because this method assigns passwords to the switch instead of to individuals who access the switch, you must distribute the password information on each switch to everyone who needs to access the switch, and you must configure and manage password protection on a per-switch basis. (For more on local authentication, see the password and username information in the *Configuration and Management Guide* on the Documentation CD-ROM shipped with your Series 4100GL switches.)

- **TACACS+ Authentication:** This method enables you to use a TACACS+ server in your network to assign a unique password, user name, and privilege level to each individual or group who needs access to one or more switches or other TACACS-aware devices. This allows you to administer primary authentication from a central server, and to do so with more options than you have when using only local authentication. (You will still need to use local authentication as a backup if your TACACS+ servers become unavailable.) This means, for example, that you can use a central TACACS+ server to grant, change, or deny access to a specific individual on a specific switch instead of having to change local user name and password assignments on the switch itself, and then have to notify other users of the change.

General System Requirements

To use TACACS+ authentication, you need the following:

- A TACACS+ server application installed and configured on one or more servers or management stations in your network. (There are several TACACS+ software packages available.)
- A switch configured for TACACS+ authentication, with access to one or more TACACS+ servers.

Notes

The effectiveness of TACACS+ security depends on correctly using your TACACS+ server application. For this reason, HP recommends that you thoroughly test all TACACS+ configurations used in your network.

TACACS-aware HP switches include the capability of configuring multiple backup TACACS+ servers. HP recommends that you use a TACACS+ server application that supports a redundant backup installation. This allows you to configure the switch to use a backup TACACS+ server if it loses access to the first-choice TACACS+ server.

In release G.05.xx, TACACS+ does not affect web browser interface access. Refer to “Controlling Web Browser Interface Access When Using TACACS+ Authentication” on page 2-24.

General Authentication Setup Procedure

It is important to test the TACACS+ service before fully implementing it. Depending on the process and parameter settings you use to set up and test TACACS+ authentication in your network, you could accidentally lock all users, including yourself, out of access to a switch. While recovery is simple, it may pose an inconvenience that can be avoided. To prevent an unintentional lockout on a Series 4100GL switch, use a procedure that configures and tests TACACS+ protection for one access type (for example, Telnet access), while keeping the other access type (console, in this case) open in case the Telnet access fails due to a configuration problem. The following procedure outlines a general setup procedure.

Note

If a complete access lockout occurs on the switch as a result of a TACACS+ configuration, see "Troubleshooting TACACS+ Operation" in the Troubleshooting chapter of the *Management and Configuration Guide* for your switch.

1. Familiarize yourself with the requirements for configuring your TACACS+ server application to respond to requests from a Series 4100GL switches. (Refer to the documentation provided with the TACACS+ server software.) This includes knowing whether you need to configure an encryption key. (See “Using the Encryption Key” on page 2-23.)

2. Determine the following:
 - The IP address(es) of the TACACS+ server(s) you want the switch to use for authentication. If you will use more than one server, determine which server is your first-choice for authentication services.
 - The encryption key, if any, for allowing the switch to communicate with the server. You can use either a global key or a server-specific key, depending on the encryption configuration in the TACACS+ server(s).
 - The number of log-in attempts you will allow before closing a log-in session. (Default: 3)
 - The period you want the switch to wait for a reply to an authentication request before trying another server.
 - The username/password pairs you want the TACACS+ server to use for controlling access to the switch.
 - The privilege level you want for each username/password pair administered by the TACACS+ server for controlling access to the switch.
 - The username/password pairs you want to use for local authentication (one pair each for Operator and Manager levels).
3. Plan and enter the TACACS+ server configuration needed to support TACACS+ operation for Telnet access (login and enable) to the switch. This includes the username/password sets for logging in at the Operator (read-only) privilege level and the sets for logging in at the Manager (read/write) privilege level.

**Note on
Privilege Levels**

When a TACACS+ server authenticates an access request from a switch, it includes a privilege level code for the switch to use in determining which privilege level to grant to the terminal requesting access. The switch interprets a privilege level code of "15" as authorization for the Manager (read/write) privilege level access. Privilege level codes of 14 and lower result in Operator (read-only) access. Thus, when configuring the TACACS+ server response to a request that includes a username/password pair that should have Manager privileges, you must use a privilege level of 15. For more on this topic, refer to the documentation you received with your TACACS+ server application.

If you are a first-time user of the TACACS+ service, HP recommends that you configure only the minimum feature set required by the TACACS+ application to provide service in your network environment. After you have success with the minimum feature set, you may then want to try additional features that the application offers.

4. Ensure that the switch has the correct local username and password for Manager access. (If the switch cannot find any designated TACACS+ servers, the local manager and operator username/password pairs are always used as the secondary access control method.)

Caution

You should ensure that the switch has a local Manager password. Otherwise, if authentication through a TACACS+ server fails for any reason, then unauthorized access will be available through the console port or Telnet.

5. Using a terminal device connected to the switch's console port, configure the switch for TACACS+ authentication *only* for **telnet login** access and **telnet enable** access. At this stage, do not configure TACACS+ authentication for console access to the switch, as you may need to use the console for access if the configuration for the Telnet method needs debugging.
6. Ensure that the switch is configured to operate on your network and can communicate with your first-choice TACACS+ server. (At a minimum, this requires IP addressing and a successful **ping** test from the switch to the server.)
7. On a remote terminal device, use Telnet to attempt to access the switch. If the attempt fails, use the console access to check the TACACS+ configuration on the switch. If you make changes in the switch configuration, check Telnet access again. If Telnet access still fails, check the configuration in your TACACS+ server application for mis-configurations or missing data that could affect the server's interoperation with the switch.
8. After your testing shows that Telnet access using the TACACS+ server is working properly, configure your TACACS+ server application for console access. Then test the console access. If access problems occur, check for and correct any problems in the switch configuration, and then test console access again. If problems persist, check your TACACS+ server application for mis-configurations or missing data that could affect the console access.
9. When you are confident that TACACS+ access through both Telnet and the switch's console operates properly, use the **write memory** command to save the switch's running-config file to flash.

Configuring TACACS+ on the Switch

Before You Begin

If you are new to TACACS+ authentication, HP recommends that you read the “General Authentication Setup Procedure” on page 2-6 and configure your TACACS+ server(s) before configuring authentication on the switch.

The switch offers three command areas for TACACS+ operation:

- **show authentication** and **show tacacs**: Displays the switch’s TACACS+ configuration and status.
- **aaa authentication**: A command for configuring the switch’s authentication methods
- **tacacs-server**: A command for configuring the switch’s contact with TACACS+ servers

CLI Commands Described in this Section

Command	Page
show authentication	2-10
show tacacs	2-10
aaa authentication console Telnet num-attempts <1..10 >	pages 2-11 through 2-14
tacacs-server	pages 2-15
host < ip-addr >	pages 2-15
key	2-19
timeout < 1 ..255 >	2-20

Viewing the Switch's Current Authentication Configuration

This command lists the number of login attempts the switch allows in a single login session, and the primary/secondary access methods configured for each type of access.

Syntax: show authentication

This example shows the default authentication configuration.

```
HPswitch> show authentication
Status and Counters - Authentication Information
Login Attempts : 3

      Login      Login      Enable  Enable
Access Task Primary Secondary Primary  Secondary
-----
(Console) Local  None    Local   None
(Telnet) Local  None    Local   None
```

Configuration for login and enable access to the switch through the switch console port.

Configuration for login and enable access to the switch through Telnet.

Figure 2-2. Example Listing of the Switch's Authentication Configuration

Viewing the Switch's Current TACACS+ Server Contact Configuration

This command lists the timeout period, encryption key, and the IP addresses of the first-choice and backup TACACS+ servers the switch can contact.

Syntax: show tacacs

For example, if the switch was configured for a first-choice and two backup TACACS+ server addresses, the default timeout period, and **paris-1** for a (global) encryption key, **show tacacs** would produce a listing similar to the following:

```
HPswitch# show tacacs
Status and Counters - TACACS Information
Timeout : 5
Encryption Key : paris-1
Server IP Addr  Opens  Closes  Aborts  Errors  Pkts Rx  Pkts Tx
-----
10.30.248.100   0      0      0      0      0      0
10.30.248.156   0      0      0      0      0      0
10.30.248.105   0      0      0      0      0      0
```

First-Choice TACACS+ Server

Second-Choice TACACS+ Server

Third-Choice TACACS+ Server

Figure 2-3. Example of the Switch's TACACS+ Configuration Listing

Configuring the Switch's Authentication Methods

The **aaa authentication** command configures the access control for console port and Telnet access to the switch. That is, for both access methods, **aaa authentication** specifies whether to use a TACACS+ server or the switch's local authentication, or (for some secondary scenarios) no authentication (meaning that if the primary method fails, authentication is denied). This command also reconfigures the number of access attempts to allow in a session if the first attempt uses an incorrect username/password pair.

Syntax: aaa authentication

< console | telnet >

Selects either console (serial port) or Telnet access for configuration.

< enable | login >

Selects either the Manager (enable) or Operator (login) access level.

< local | tacacs | radius >

Selects the type of security access:

local — Authenticates with the Manager and Operator password you configure in the switch.

tacacs — Authenticates with a password and other data configured on a TACACS+ server.

radius — Authenticates with a password and other data configured on a RADIUS server. (Refer to "RADIUS Authentication and Accounting" on page 3-1.)

[< local | none >]

If the primary authentication method fails, determines whether to use the local password as a secondary method or to disallow access.

aaa authentication num-attempts < 1 . 10 >

Specifies the maximum number of login attempts allowed in the current session. Default: 3

Table 2-1. AAA Authentication Parameters

Name	Default	Range	Function
console - or - telnet	n/a	n/a	Specifies whether the command is configuring authentication for the console port or Telnet access method for the switch.
enable - or - login	n/a	n/a	Specifies the privilege level for the access method being configured. login: Operator (read-only) privileges enable: Manager (read-write) privileges
local - or - tacacs	local	n/a	Specifies the primary method of authentication for the access method being configured. local: Use the username/password pair configured locally in the switch for the privilege level being configured tacacs: Use a TACACS+ server.
local - or - none	none	n/a	Specifies the secondary (backup) type of authentication being configured. local: The username/password pair configured locally in the switch for the privilege level being configured none: No secondary type of authentication for the specified method/privilege path. (Available only if the primary method of authentication for the access being configured is local.) Note: If you do not specify this parameter in the command line, the switch automatically assigns the secondary method as follows: <ul style="list-style-type: none">• If the primary method is tacacs, the only secondary method is local.• If the primary method is local, the default secondary method is none.
num-attempts	3	1 - 10	In a given session, specifies how many tries at entering the correct username/password pair are allowed before access is denied and the session terminated.

As shown in the next table, login and enable access is always available locally through a direct terminal connection to the switch's console port. However, for Telnet access, you can configure TACACS+ to deny access if a TACACS+ server goes down or otherwise becomes unavailable to the switch.

Table 2-2. Primary/Secondary Authentication Table

Access Method and Privilege Level	Authentication Options		Effect on Access Attempts
	Primary	Secondary	
Console — Login	local	none*	Local username/password access only.
	tacacs	local	If Tacacs+ server unavailable, uses local username/password access.
Console — Enable	local	none*	Local username/password access only.
	tacacs	local	If Tacacs+ server unavailable, uses local username/password access.
Telnet — Login	local	none*	Local username/password access only.
	tacacs	local	If Tacacs+ server unavailable, uses local username/password access.
	tacacs	none	If Tacacs+ server unavailable, denies access.
Telnet — Enable	local	none*	Local username/password access only.
	tacacs	local	If Tacacs+ server unavailable, uses local username/password access.
	tacacs	none	If Tacacs+ server unavailable, denies access.

*When "local" is the primary option, you can also select "local" as the secondary option. However, in this case, a secondary "local" is meaningless because the switch has only one local level of username/password protection.

Caution Regarding the Use of Local for Login Primary Access

During local authentication (which uses passwords configured in the switch instead of in a TACACS+ server), the switch grants read-only access if you enter the Operator password, and read-write access if you enter the Manager password. For example, if you configure authentication on the switch with Telnet Login Primary as Local and Telnet Enable Primary as Tacacs, when you attempt to Telnet to the switch, you will be prompted for a local password. If you enter the switch's local Manager password (or, if there is no local Manager password configured in the switch) you can bypass the TACACS+ server authentication for Telnet Enable Primary and go directly to read-write (Manager) access. Thus, for either the Telnet or console access method, configuring Login Primary for Local authentication while configuring Enable Primary for TACACS+ authentication is not recommended, as it defeats the purpose of using the TACACS+ authentication. If you want Enable Primary log-in attempts to go to a TACACS+ server, then you should configure both Login Primary and Enable Primary for Tacacs authentication instead of configuring Login Primary to Local authentication.

TACACS+ Authentication
Configuring TACACS+ on the Switch

For example, here is a set of access options and the corresponding commands to configure them:

**Console Login (Operator or Read-Only) Access: Primary using TACACS+ server.
Secondary using Local.**

```
HPswitch (config)# aaa authentication console login tacacs local
```

<i>Console Login (Operator or Read-Only Access)</i>	<i>Primary</i>	<i>Secondary</i>
---	----------------	------------------

**Console Enable (Manager or Read/Write Access: Primary using TACACS+ server.
Secondary using Local.**

```
HPswitch (config)# aaa authentication console enable tacacs local
```

<i>Console Login (Operator or Read-Only Access)</i>	<i>Primary</i>	<i>Secondary</i>
---	----------------	------------------

**Telnet Login (Operator or Read-Only) Access: Primary using TACACS+ server.
Secondary using Local.**

```
HPswitch (config)# aaa authentication Telnet login tacacs local
```

<i>Console Login (Operator or Read-Only Access)</i>	<i>Primary</i>	<i>Secondary</i>
---	----------------	------------------

**Telnet Enable (Manager or Read/Write Access: Primary using TACACS+ server.
Secondary using Local.**

```
HPswitch (config)# aaa authentication telnet enable tacacs local
```

<i>Console Login (Operator or Read-Only Access)</i>	<i>Primary</i>	<i>Secondary</i>
---	----------------	------------------

Deny Access and Close the Session After Failure of Two Consecutive Username/Password Pairs:

```
HPswitch(config)# aaa authentication num-attempts 2
```

<i>Attempt Limit</i>

Configuring the Switch's TACACS+ Server Access

The `tacacs-server` command configures these parameters:

- **The host IP address(es)** for up to three TACACS+ servers; one first-choice and up to two backups. Designating backup servers provides for a continuation of authentication services in case the switch is unable to contact the first-choice server.
- **An optional encryption key.** This key helps to improve security, and must match the encryption key used in your TACACS+ server application. In some applications, the term "secret key" or "secret" may be used instead of "encryption key". If you need only one encryption key for the switch to use in all attempts to authenticate through a TACACS+ server, configure a global key. However, if the switch is configured to access multiple TACACS+ servers having different encryption keys, you can configure the switch to use different encryption keys for different TACACS+ servers.
- **The timeout value** in seconds for attempts to contact a TACACS+ server. If the switch sends an authentication request, but does not receive a response within the period specified by the timeout value, the switch resends the request to the next server in its Server IP Addr list, if any. If the switch still fails to receive a response from any TACACS+ server, it reverts to whatever secondary authentication method was configured using the **aaa authentication** command (local or none; see "Configuring the Switch's Authentication Methods" on page 2-11.)

Note

As described under "General Authentication Setup Procedure" on page 2-6, HP recommends that you configure, test, and troubleshoot authentication via Telnet access before you configure authentication via console port access. This helps to prevent accidentally locking yourself out of switch access due to errors or problems in setting up authentication in either the switch or your TACACS+ server.

Syntax: tacacs-server host < ip-addr > [key < key-string >]

Adds a TACACS+ server and optionally assigns a server-specific encryption key.

[no] tacacs-server host < ip-addr >

Removes a TACACS+ server assignment (including its server-specific encryption key, if any).

tacacs-server key <key-string>

Enters the optional global encryption key.

[no] tacacs-server key

Removes the optional global encryption key. (Does not affect any server-specific encryption key assignments.)

tacacs-server timeout < 1 . . 255 >

Changes the wait period for a TACACS server response. (Default: 5 seconds.)

**Note on
Encryption Keys**

Encryption keys configured in the switch must exactly match the encryption keys configured in TACACS+ servers the switch will attempt to use for authentication.

If you configure a global encryption key, the switch uses it only with servers for which you have not also configured a server-specific key. Thus, a global key is more useful where the TACACS+ servers you are using all have an identical key, and server-specific keys are necessary where different TACACS+ servers have different keys.

If TACACS+ server “X” does not have an encryption key assigned for the switch, then configuring either a global encryption key or a server-specific key in the switch for server “X” will block authentication support from server “X”.

Name	Default	Range
host <ip-addr> [key <key-string>	none	n/a

Specifies the IP address of a device running a TACACS+ server application. Optionally, can also specify the unique, per-server encryption key to use when each assigned server has its own, unique key. For more on the encryption key, see "Using the Encryption Key" on page 2-23 and the documentation provided with your TACACS+ server application.

You can enter up to three IP addresses; one first-choice and two (optional) backups (one second-choice and one third-choice).

Use **show tacacs** to view the current IP address list.

If the first-choice TACACS+ server fails to respond to a request, the switch tries the second address, if any, in the show tacacs list. If the second address also fails, then the switch tries the third address, if any.

(See figure 2-3, "Example of the Switch's TACACS+ Configuration Listing" on 2-10.)

The priority (first-choice, second-choice, and third-choice) of a TACACS+ server in the switch's TACACS+ configuration depends on the order in which you enter the server IP addresses:

1. When there are no TACACS+ servers configured, entering a server IP address makes that server the first-choice TACACS+ server.
 2. When there is one TACACS+ server already configured, entering another server IP address makes that server the second-choice (backup) TACACS+ server.
 3. When there are two TACACS+ servers already configured, entering another server IP address makes that server the third-choice (backup) TACACS+ server.
- The above position assignments are fixed. Thus, if you remove one server and replace it with another, the new server assumes the priority position that the removed server had. For example, suppose you configured three servers, A, B, and C, configured in order:
 - First-Choice: A
 - Second-Choice: B
 - Third-Choice: C
 - If you removed server B and then entered server X, the TACACS+ server order of priority would be:
 - First-Choice: A
 - Second-Choice: X
 - Third-Choice: C
 - If there are two or more vacant slots in the TACACS+ server priority list and you enter a new IP address, the new address will take the vacant slot with the highest priority. Thus, if A, B, and C are configured as above and you (1) remove A and B, and (2) enter X and Y (in that order), then the new TACACS+ server priority list would be X, Y, and C.
 - The easiest way to change the order of the TACACS+ servers in the priority list is to remove all server addresses in the list and then re-enter them in order, with the new first-choice server address first, and so on.
- To add a new address to the list when there are already three addresses present, you must first remove one of the currently listed addresses.

See also "General Authentication Process Using a TACACS+ Server" on page 2-20.

TACACS+ Authentication
 Configuring TACACS+ on the Switch

Name	Default	Range
key <key-string>	none (null)	n/a
<p>Specifies the optional, global "encryption key" that is also assigned in the TACACS+ server(s) that the switch will access for authentication. This option is subordinate to any "per-server" encryption keys you assign, and applies only to accessing TACACS+ servers for which you have not given the switch a "per-server" key. (See the host <ip-addr> [key <key-string> entry at the beginning of this table.)</p> <p>For more on the encryption key, see "Using the Encryption Key" on page 2-23 and the documentation provided with your TACACS+ server application.</p>		
timeout <1..255>	5 sec	1 - 255 sec
<p>Specifies how long the switch waits for a TACACS+ server to respond to an authentication request. If the switch does not detect a response within the timeout period, it initiates a new request to the next TACACS+ server in the list. If all TACACS+ servers in the list fail to respond within the timeout period, the switch uses either local authentication (if configured) or denies access (if none configured for local authentication).</p>		

Adding, Removing, or Changing the Priority of a TACACS+ Server.

Suppose that the switch was already configured to use TACACS+ servers at 10.28.227.10 and 10.28.227.15. In this case, 10.28.227.15 was entered first, and so is listed as the first-choice server:

```

HPswitch# show tacacs
Status and Counters - T&A&C&S Information
Timeout : 5
Encryption Key : First-Choice TACACS+ Server
Server IP Addr  Closes  Aborts  Errors  Pkts Rx  Pkts Tx
-----
10.28.227.15   0        0        0        0        0
10.28.227.10   0        0        0        0        0
  
```

Figure 2-4. Example of the Switch with Two TACACS+ Server Addresses Configured

To move the "first-choice" status from the "15" server to the "10" server, use the **no tacacs-server host <ip-addr>** command to delete both servers, then use **tacacs-server host <ip-addr>** to re-enter the "10" server first, then the "15" server.

The servers would then be listed with the new "first-choice" server, that is:

```
HPswitch# show tacacs
Status and Counters - TACACS Information
Timeout : 5
Encryption Key :
Server IP Addr Opens Closes Aborts Errors Pkts Rx Pkts Tx
-----
10.28.227.10 0 0 0 0 0 0 0
10.28.227.15 0 0 0 0 0 0 0
```

The "10" server is now the "first-choice" TACACS+ authentication device.

Figure 2-5. Example of the Switch After Assigning a Different "First-Choice" Server

To remove the 10.28.227.15 device as a TACACS+ server, you would use this command:

```
HPswitch(config)# no tacacs-server host 10.28.227.15
```

Configuring an Encryption Key. Use an encryption key in the switch if the switch will be requesting authentication from a TACACS+ server that also uses an encryption key. (If the server expects a key, but the switch either does not provide one, or provides an incorrect key, then the authentication attempt will fail.) Use a *global encryption key* if the same key applies to all TACACS+ servers the switch may use for authentication attempts. Use a *per-server encryption key* if different servers the switch may use will have different keys. (For more details on encryption keys, see "Using the Encryption Key" on page 2-23.)

To configure **north01** as a global encryption key:

```
HPswitch(config) tacacs-server key north01
```

To configure **north01** as a per-server encryption key:

```
HPswitch(config) tacacs-server host 10.28.227.63 key north01
```

An encryption key can contain up to 100 characters, without spaces, and is likely to be case-sensitive in most TACACS+ server applications.

To delete a global encryption key from the switch, use this command:

```
HPswitch(config)# no tacacs-server key
```

To delete a per-server encryption key in the switch, re-enter the `tacacs-server host` command without the `key` parameter. For example, if you have **north01** configured as the encryption key for a TACACS+ server with an IP address of 10.28.227.104 and you want to eliminate the key, you would use this command:

```
HPswitch(config)# tacacs-server host 10.28.227.104
```

Note

The `show tacacs` command lists the global encryption key, if configured. However, to view any configured per-server encryption keys, you must use **show config** or **show config running** (if you have made TACACS+ configuration changes without executing `write mem`).

Configuring the Timeout Period. The timeout period specifies how long the switch waits for a response to an authentication request from a TACACS+ server before either sending a new request to the next server in the switch's Server IP Address list or using the local authentication option. For example, to change the timeout period from 5 seconds (the default) to 3 seconds:

```
HPswitch(config)# tacacs-server timeout 3
```

How Authentication Operates

General Authentication Process Using a TACACS+ Server

Authentication through a TACACS+ server operates generally as described below. For specific operating details, refer to the documentation you received with your TACACS+ server application.

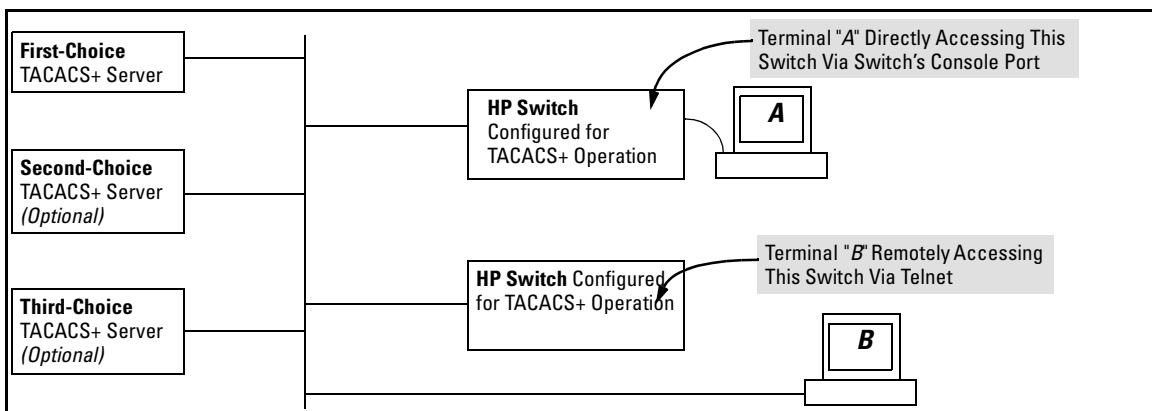

Figure 2-6. Using a TACACS+ Server for Authentication

Using figure 2-6, above, after either switch detects an operator's logon request from a remote or directly connected terminal, the following events occur:

1. The switch queries the first-choice TACACS+ server for authentication of the request.
 - If the switch does not receive a response from the first-choice TACACS+ server, it attempts to query a secondary server. If the switch does not receive a response from any TACACS+ server, then it uses its own local username/password pairs to authenticate the logon request. (See "Local Authentication Process" on page 2-22.)
 - If a TACACS+ server recognizes the switch, it forwards a username prompt to the requesting terminal via the switch.
2. When the requesting terminal responds to the prompt with a username, the switch forwards it to the TACACS+ server.
3. After the server receives the username input, the requesting terminal receives a password prompt from the server via the switch.
4. When the requesting terminal responds to the prompt with a password, the switch forwards it to the TACACS+ server and one of the following actions occurs:
 - If the username/password pair received from the requesting terminal matches a username/password pair previously stored in the server, then the server passes access permission through the switch to the terminal.
 - If the username/password pair entered at the requesting terminal does not match a username/password pair previously stored in the server, access is denied. In this case, the terminal is again prompted to enter a username and repeat steps 2 through 4. In the default configuration, the switch allows up to three attempts to authenticate a login session. If the requesting terminal exhausts the attempt limit without a successful TACACS+ authentication, the login session is terminated and the operator at the requesting terminal must initiate a new session before trying again.

Local Authentication Process

When the switch is configured to use TACACS+, it reverts to local authentication only if one of these two conditions exists:

- "Local" is the authentication option for the access method being used.
- TACACS+ is the primary authentication mode for the access method being used. However, the switch was unable to connect to any TACACS+ servers (or no servers were configured) AND **Local** is the secondary authentication mode being used.

(For a listing of authentication options, see table 2-2, "Primary/Secondary Authentication Table" on 2-13.)

For local authentication, the switch uses the operator-level and manager-level username/password set(s) previously configured locally on the switch. (These are the usernames and passwords you can configure using the CLI password command, the web browser interface, or the menu interface—which enables only local password configuration).

- If the operator at the requesting terminal correctly enters the username/password pair for either access level, access is granted.
- If the username/password pair entered at the requesting terminal does not match either username/password pair previously configured locally in the switch, access is denied. In this case, the terminal is again prompted to enter a username/password pair. In the default configuration, the switch allows up to three attempts. If the requesting terminal exhausts the attempt limit without a successful authentication, the login session is terminated and the operator at the requesting terminal must initiate a new session before trying again.

Note

The switch's menu allows you to configure only the local Operator and Manager passwords, and not any usernames. In this case, all prompts for local authentication will request only a local password. However, if you use the CLI or the web browser interface to configure usernames for local access, you will see a prompt for both a local username and a local password during local authentication.

Using the Encryption Key

General Operation

When used, the encryption key (sometimes termed "key", "secret key", or "secret") helps to prevent unauthorized intruders on the network from reading username and password information in TACACS+ packets moving between the switch and a TACACS+ server. At the TACACS+ server, a key may include both of the following:

- **Global key:** A general key assignment in the TACACS+ server application that applies to all TACACS-aware devices for which an individual key has not been configured.
- **Server-Specific key:** A unique key assignment in the TACACS+ server application that applies to a specific TACACS-aware device.

Note

Configure a key in the switch only if the TACACS+ server application has this exact same key configured for the switch. That is, if the key parameter in switch "X" does not exactly match the key setting for switch "X" in the TACACS+ server application, then communication between the switch and the TACACS+ server will fail.

Thus, on the TACACS+ server side, you have a choice as to how to implement a key. On the switch side, it is necessary only to enter the key parameter so that it exactly matches its counterpart in the server. For information on how to configure a general or individual key in the TACACS+ server, refer to the documentation you received with the application.

Encryption Options in the Switch

When configured, the encryption key causes the switch to encrypt the TACACS+ packets it sends to the server. When left at "null", the TACACS+ packets are sent in clear text. The encryption key (or just "key") you configure in the switch must be identical to the encryption key configured in the corresponding TACACS+ server. If the key is the same for all TACACS+ servers the switch will use for authentication, then configure a global key in the switch. If the key is different for one or more of these servers, use "server-specific" keys in the switch. (If you configure both a global key and one or more per-server keys, the per-server keys will override the global key for the specified servers.)

For example, you would use the next command to configure a global encryption key in the switch to match a key entered as **north40campus** in two target TACACS+ servers. (That is, both servers use the same key for your switch.) Note that you do not need the server IP addresses to configure a global key in the switch:

```
HPswitch(config)# tacacs-server key north40campus
```

Suppose that you subsequently add a third TACACS+ server (with an IP address of 10.28.227.87) that has **south10campus** for an encryption key. Because this key is different than the one used for the two servers in the previous example, you will need to assign a server-specific key in the switch that applies only to the designated server:

```
HPswitch(config)# tacacs-server host 10.28.227.87 key south10campus
```

With both of the above keys configured in the switch, the **south10campus** key overrides the **north40campus** key only when the switch tries to access the TACACS+ server having the 10.28.227.87 address.

Controlling Web Browser Interface Access When Using TACACS+ Authentication

Configuring the switch for TACACS+ authentication does not affect web browser interface access. To prevent unauthorized access through the web browser interface, do one or more of the following:

- Configure local authentication (a Manager user name and password and, optionally, an Operator user name and password) on the switch.
- Configure the switch's Authorized IP Manager feature to allow web browser access only from authorized management stations. (The Authorized IP Manager feature does not interfere with TACACS+ operation.)
- Disable web browser access to the switch by going to the System Information screen in the Menu interface and configuring the **Web Agent Enabled** parameter to **No**.

Messages Related to TACACS+ Operation

The switch generates the CLI messages listed below. However, you may see other messages generated in your TACACS+ server application. For information on such messages, refer to the documentation you received with the application.

CLI Message	Meaning
Connecting to Tacacs server	The switch is attempting to contact the TACACS+ server identified in the switch's tacacs-server configuration as the first-choice (or only) TACACS+ server.
Connecting to secondary Tacacs server	The switch was not able to contact the first-choice TACACS+ server, and is now attempting to contact the next (secondary) TACACS+ server identified in the switch's tacacs-server configuration.
Invalid password	The system does not recognize the username or the password or both. Depending on the authentication method (tacacs or local), either the TACACS+ server application did not recognize the username/password pair or the username/password pair did not match the username/password pair configured in the switch.
No Tacacs servers responding	The switch has not been able to contact any designated TACACS+ servers. If this message is followed by the Username prompt, the switch is attempting local authentication.
Not legal combination of authentication methods	For console access , if you select tacacs as the primary authentication method, you must select local as the secondary authentication method. This prevents you from being locked out of the switch if all designated TACACS+ servers are inaccessible to the switch.
Record already exists	When resulting from a tacacs-server host <ip addr> command, indicates an attempt to enter a duplicate TACACS+ server IP address.

Operating Notes

- If you configure Authorized IP Managers on the switch, it is not necessary to include any devices used as TACACS+ servers in the authorized manager list. That is, authentication traffic between a TACACS+ server and the switch is not subject to Authorized IP Manager controls configured on the switch. Also, the switch does not attempt TACACS+ authentication for a management station that the Authorized IP Manager list excludes because, independent of TACACS+, the switch already denies access to such stations.

- When TACACS+ is not enabled on the switch—or when the switch's only designated TACACS+ servers are not accessible— setting a local Operator password without also setting a local Manager password does not protect the switch from manager-level access by unauthorized persons.)

RADIUS Authentication and Accounting

Contents

Overview	3-2
Terminology	3-3
Switch Operating Rules for RADIUS	3-4
General RADIUS Setup Procedure	3-5
Configuring the Switch for RADIUS Authentication	3-6
Outline of the Steps for Configuring RADIUS Authentication	3-6
1. Configure Authentication for the Access Methods You Want RADIUS To Protect	3-8
2. Configure the Switch To Access a RADIUS Server	3-10
3. Configure the Switch's Global RADIUS Parameters	3-12
Local Authentication Process	3-14
Controlling Web Browser Interface Access When Using RADIUS Authentication	3-15
Configuring RADIUS Accounting	3-16
Operating Rules for RADIUS Accounting	3-17
Steps for Configuring RADIUS Accounting	3-18
1. Configure the Switch To Access a RADIUS Server	3-19
2. Configure Accounting Types and the Controls for Sending Reports to the RADIUS Server	3-20
3. (Optional) Configure Session Blocking and Interim Updating Options	3-22
Viewing RADIUS Statistics	3-23
General RADIUS Statistics	3-23
RADIUS Authentication Statistics	3-25
RADIUS Accounting Statistics	3-26
Changing RADIUS-Server Access Order	3-27
Messages Related to RADIUS Operation	3-29

Overview

Feature	Default	Menu	CLI	Web
Configuring RADIUS Authentication	None	n/a	3-6	n/a
Configuring RADIUS Accounting	None	n/a	3-16	n/a
Viewing RADIUS Statistics	n/a	n/a	3-23	n/a

RADIUS (*Remote Authentication Dial-In User Service*) enables you to use up to three servers (one primary server and one or two backups) and maintain separate authentication and accounting for each RADIUS server employed. For authentication, this allows a different password for each user instead of having to rely on maintaining and distributing switch-specific passwords to all users. For accounting, this can help you track network resource usage.

Authentication. You can use RADIUS to verify user identity for the following types of primary password access to the HP switch:

- Serial port (Console)
- Telnet
- SSH
- Port-Access

Note

The switch does not support RADIUS security for SNMP (network management) access or web browser interface access. For steps to block unauthorized access through the web browser interface, see “Controlling Web Browser Interface Access When Using RADIUS Authentication” on page 3-15.

Accounting. RADIUS accounting on the switch collects resource consumption data and forwards it to the RADIUS server. This data can be used for trend analysis, capacity planning, billing, auditing, and cost analysis.

Terminology

CHAP (Challenge-Handshake Authentication Protocol): A challenge-response authentication protocol that uses the Message Digest 5 (MD5) hashing scheme to encrypt a response to a challenge from a RADIUS server.

EAP(Extensible Authentication Protocol): A general PPP authentication protocol that supports multiple authentication mechanisms. A specific authentication mechanism is known as an EAP type, such as MD5-Challenge, Generic Token Card, and TLS (Transport Level Security).

Host: See **RADIUS Server**.

NAS (Network Access Server): In this case, an HP switch configured for RADIUS security operation.

RADIUS (Remote Authentication Dial In User Service):

RADIUS Client: The device that passes user information to designated RADIUS servers.

RADIUS Host: See RADIUS server.

RADIUS Server: A server running the RADIUS application you are using on your network. This server receives user connection requests from the switch, authenticates users, and then returns all necessary information to the switch. For the HP switch, a RADIUS server can also perform accounting functions. Sometimes termed a *RADIUS host*.

Shared Secret Key: A text value used for encrypting data in RADIUS packets. Both the RADIUS client and the RADIUS server have a copy of the key, and the key is never transmitted across the network.

Switch Operating Rules for RADIUS

- You must have at least one RADIUS server accessible to the switch.
- The switch supports authentication and accounting using up to three RADIUS servers. The switch accesses the servers in the order in which they are listed by **show radius** (page 3-23). If the first server does not respond, the switch tries the next one, and so-on. (To change the order in which the switch accesses RADIUS servers, refer to “Changing RADIUS-Server Access Order” on page 3-27.)
- You can select RADIUS as the primary authentication method for each type of access. (Only one primary and one secondary access method is allowed for each access type.)
- In the HP switch, EAP RADIUS uses MD5 and TLS to encrypt a response to a challenge from a RADIUS server.

General RADIUS Setup Procedure

Preparation:

1. Configure one to three RADIUS servers to support the switch. (That is, one primary server and one or two backups.) Refer to the documentation provided with the RADIUS server application.
2. Before configuring the switch, collect the information outlined below.

Table 3-1. Preparation for Configuring RADIUS on the Switch

- Determine the access methods (console, Telnet, Port-Access, and/or SSH) for which you want RADIUS as the primary authentication method. Consider both Operator (login) and Manager (enable) levels, as well as which secondary authentication methods to use (local or none) if the RADIUS authentication fails or does not respond.

```
HPswitch> show authentication
```

Status and Counters - Authentication Information				
Login Attempts : 3				
Access Task	Login Primary	Login Secondary	Enable Primary	Enable Secondary
Console	Radius	Local	Radius	Local
Telnet	Radius	None	Radius	None
Port-Access	EapRadius			
SSH	Radius	None	Radius	None

Console access requires Local as secondary method to prevent lockout if the primary RADIUS access fails due to loss of RADIUS server access or other problems with the server.

Figure 3-1. Example of Possible RADIUS Access Assignments

- Determine the IP address(es) of the RADIUS server(s) you want to support the switch. (You can configure the switch for up to three RADIUS servers.)
- If you need to replace the default UDP destination port (1812) the switch uses for authentication requests to a specific RADIUS server, select it before beginning the configuration process.
- If you need to replace the default UDP destination port (1813) the switch uses for accounting requests to a specific Radius server, select it before beginning the configuration process.
- Determine whether you can use one, global encryption key for all RADIUS servers or if unique keys will be required for specific servers. With multiple RADIUS servers, if one key applies to two or more of these servers, then you can configure this key as the global encryption key. For any server whose key differs from the global key you are using, you must configure that key in the same command that you use to designate that server's IP address to the switch.
- Determine an acceptable timeout period for the switch to wait for a server to respond to a request. HP recommends that you begin with the default (five seconds).
- Determine how many times you want the switch to try contacting a RADIUS server before trying another RADIUS server or quitting. (This depends on how many RADIUS servers you have configured the switch to access.)
- Determine whether you want to bypass a RADIUS server that fails to respond to requests for service. To shorten authentication time, you can set a bypass period in the range of 1 to 1440 minutes for non-responsive servers. This requires that you have multiple RADIUS servers accessible for service requests.

Configuring the Switch for RADIUS Authentication

RADIUS Authentication Commands	Page
aaa authentication	3-8
< console telnet ssh > < enable login > radius	3-8
< local none >	3-8
[no] radius-server host < IP-address >	3-10
[auth-port < port-number >]	3-10
[acct-port < port-number >]	3-10, 3-19
[key < server-specific key-string >]	3-10
[no] radius-server key < global key-string >	3-12
radius-server timeout < 1 .. 15 >	3-12
radius-server retransmit < 1 .. 5 >	3-12
[no] radius-server dead-time < 1 .. 1440 >	3-13
show radius	3-23
[< host < ip-address >]	3-23
show authentication	3-25
show radius authentication	3-25

Outline of the Steps for Configuring RADIUS Authentication

There are three main steps to configuring RADIUS authentication:

1. Configure RADIUS authentication for controlling access through one or more of the following
 - Serial port
 - Telnet
 - SSH
 - Port-Access (802.1x)
2. Configure the switch for accessing one or more RADIUS servers (one primary server and up to two backup servers):

Note

This step assumes you have already configured the RADIUS server(s) to support the switch. Refer to the documentation provided with the RADIUS server documentation.)

- Server IP address
 - (Optional) UDP destination port for authentication requests (default: 1812; recommended)
 - (Optional) UDP destination port for accounting requests (default: 1813; recommended)
 - (Optional) encryption key for use during authentication sessions with a RADIUS server. This key overrides the global encryption key you can also configure on the switch, and must match the encryption key used on the specified RADIUS server. (Default: null)
3. Configure the global RADIUS parameters.
- **Server Key:** This key must match the encryption key used on the RADIUS servers the switch contacts for authentication and accounting services unless you configure one or more per-server keys. (Default: null.)
 - **Timeout Period:** The timeout period the switch waits for a RADIUS server to reply. (Default: 5 seconds; range: 1 to 15 seconds.)
 - **Retransmit Attempts:** The number of retries when there is no server response to a RADIUS authentication request. (Default: 3; range of 1 to 5.)
 - **Server Dead-Time:** The period during which the switch will not send new authentication requests to a RADIUS server that has failed to respond to a previous request. This avoids a wait for a request to time out on a server that is unavailable. If you want to use this feature, select a dead-time period of 1 to 1440 minutes. (Default: 0—disabled; range: 1 - 1440 minutes.) If your first-choice server was initially unavailable, but then becomes available before the dead-time expires, you can nullify the dead-time by resetting it to zero and then trying to log on again. As an alternative, you can reboot the switch, (thus resetting the dead-time counter to assume the server is available) and then try to log on again.
 - **Number of Login Attempts:** This is actually an **aaa authentication** command. It controls how many times in one session a RADIUS client (as well as clients using other forms of access) can try to log in with the correct username and password. (Default: Three times per session.)

(For RADIUS accounting features, refer to “Configuring RADIUS Accounting” on page 3-16.)

1. Configure Authentication for the Access Methods You Want RADIUS To Protect

This section describes how to configure the switch for RADIUS authentication through the following access methods:

- **Console:** Either direct serial-port connection or modem connection.
- **Telnet:** Inbound Telnet must be enabled (the default).
- **SSH:** To employ RADIUS for SSH access, you must first configure the switch for SSH operation. Refer to “Configuring Secure Shell (SSH)” on page 4-1.

You can also use RADIUS for Port-Based Access authentication. Refer to “Configuring Port-Based Access Control (802.1x)” on page 5-1.

You can configure RADIUS as the primary password authentication method for the above access methods. You will also need to select either **local** or **none** as a secondary, or backup, method. Note that for console access, if you configure **radius** (or **tacacs**) for primary authentication, you must configure **local** for the secondary method. This prevents the possibility of being completely locked out of the switch in the event that all primary access methods fail.

Syntax: `aaa authentication < console | telnet | ssh > < enable | login > < radius >`

Configures RADIUS as the primary password authentication method for console, Telnet, and/or SSH. (The default primary < enable | login > authentication is local.)

`[< local | none >]`

Provides options for secondary authentication (default: none). Note that for console access, secondary authentication must be local if primary access is not local. This prevents you from being completely locked out of the switch in the event of a failure in other access methods.

For example, suppose you have already configured local passwords on the switch, but want to use RADIUS to protect primary Telnet and SSH access without allowing a secondary Telnet or SSH access option (which would be the switch's local passwords):

```

HPswitch(config)# aaa authentication telnet login radius none
HPswitch(config)# aaa authentication telnet enable radius none
HPswitch(config)# aaa authentication ssh login radius none
HPswitch(config)# aaa authentication ssh enable radius none
HPswitch(config)# show authentication
Status and Counters - Authentication Information
  Login Attempts : 3

```

Access Task	Login Primary	Login Secondary	Enable Primary	Enable Secondary
Console	Local	None	Local	None
Telnet	Radius	None	Radius	None
Port-Access	Local			
SSH	Radius	None	Radius	None

The switch now allows Telnet and SSH authentication only through

Figure 3-2. Example Configuration for RADIUS Authentication

Note

In the above example, if you configure the Login Primary method as **local** instead of **radius** (and local passwords are configured on the switch), then you can gain access to either the Operator or Manager level without encountering the RADIUS authentication specified for Enable Primary. Refer to “Local Authentication Process” on page 3-14.

2. Configure the Switch To Access a RADIUS Server

This section describes how to configure the switch to interact with a RADIUS server for both authentication and accounting services.

Note

If you want to configure RADIUS accounting on the switch, go to page 3-16: “Configuring RADIUS Accounting” instead of continuing here.

Syntax: [no] radius-server host < ip-address >

*Adds a server to the RADIUS configuration or (with **no**) deletes a server from the configuration. You can configure up to three RADIUS server addresses. The switch uses the first server it successfully accesses. (Refer to "Changing the RADIUS Server Access Order" on page 3-27.)*

[auth-port < port-number >]

*Optional. Changes the UDP destination port for authentication requests to the specified RADIUS server (host). If you do not use this option with the **radius-server host** command, the switch automatically assigns the default authentication port number. The **auth-port** number must match its server counterpart. (Default: **1812**)*

[acct-port < port-number >]

*Optional. Changes the UDP destination port for accounting requests to the specified RADIUS server. If you do not use this option with the **radius-server host** command, the switch automatically assigns the default accounting port number. The **acct-port** number must match its server counterpart. (Default: **1813**)*

[key < key-string >]

Optional. Specifies an encryption key for use during authentication (or accounting) sessions with the specified server. This key must match the encryption key used on the RADIUS server. Use this command only if the specified server requires a different encryption key than configured for the global encryption key.

no radius-server host < ip-address > key

*Use the **no** form of the command to remove the key for a specified server.*

For example, suppose you have configured the switch as shown in figure 3-3 and you now need to make the following changes:

1. Change the encryption key for the server at 10.33.18.127 to "source0127".
2. Add a RADIUS server with an IP address of 10.33.18.119 and a server-specific encryption key of "source0119".

```
HPswitch# show radius
Status and Counters - General RADIUS Information
  Deadtime(min) : 0
  Timeout(secs) : 5
  Retransmit Attempts : 5
  Global Encryption Key :

  Server IP Addr  Auth  Acct  Encryption Key
  -----
  10.33.18.127   1812  1813  TempKey01
```

Figure 3-3. Sample Configuration for RADIUS Server Before Changing the Key and Adding Another Server

To make the changes listed prior to figure 3-3, you would do the following:

```
HPswitch(config)# radius-server host 10.33.18.127 key source0127
HPswitch(config)# radius-server host 10.33.18.119 key source0119
HPswitch(config)# show radius
Status and Counters - General RADIUS Information
  Deadtime(min) : 0
  Timeout(secs) : 5
  Retransmit Attempts : 5
  Global Encryption Key :

  Server IP Addr  Auth  Acct  Encryption Key
  -----
  10.33.18.127   1812  1813  source0127
  10.33.18.119   1812  1813  source0119
```

Changes the key for the existing server to "source0127" (step

Adds the new RADIUS server with its required "source0119" key.

Lists the switch's new RADIUS server configuration. Compare this with

Figure 3-4. Sample Configuration for RADIUS Server After Changing the Key and Adding Another Server

To change the order in which the switch accesses RADIUS servers, refer to "Changing RADIUS-Server Access Order" on page 3-27.

3. Configure the Switch's Global RADIUS Parameters

You can configure the switch for the following global RADIUS parameters:

- **Number of login attempts:** In a given session, specifies how many tries at entering the correct username and password pair are allowed before access is denied and the session terminated. (This is a general **aaa authentication** parameter and is not specific to RADIUS.)
- **Global server key:** The server key the switch will use for contacts with all RADIUS servers for which there is not a server-specific key configured by **radius-server host < ip-address > key < key-string >**. This key is optional if you configure a server-specific key for each RADIUS server entered in the switch. (Refer to “2. Configure the Switch To Access a RADIUS Server” on page 3-10.)
- **Server timeout:** Defines the time period in seconds for authentication attempts. If the timeout period expires before a response is received, the attempt fails.
- **Server dead time:** Specifies the time in minutes during which the switch avoids requesting authentication from a server that has not responded to previous requests.
- **Retransmit attempts:** If the first attempt to contact a RADIUS server fails, specifies how many retries you want the switch to attempt on that server.

Syntax: aaa authentication num-attempts <1 .. 10 >

Specifies how many tries for entering the correct username and password before shutting down the session due to input errors. (Default: 3; Range: 1 - 10).

[no] radius-server

key < global-key-string >

Specifies the global encryption key the switch uses with servers for which the switch does not have a server-specific key assignment. This key is optional if all RADIUS server addresses configured in the switch include a server-specific encryption key. (Default: Null.)

dead-time < 1 .. 1440 >

Optional. Specifies the time in minutes during which the switch will not attempt to use a RADIUS server that has not responded to an earlier authentication attempt. (Default: 0; Range: 1 - 1440 minutes)

radius-server timeout < 1 .. 15 >

Specifies the maximum time the switch waits for a response to an authentication request before counting the attempt as a failure. (Default: 3 seconds; Range: 1 - 15 seconds)

radius-server retransmit < 1 .. 5 >

If a RADIUS server fails to respond to an authentication request, specifies how many retries to attempt before closing the session. Default: 3; Range: 1 - 5)

Note

Where the switch has multiple RADIUS servers configured to support authentication requests, if the first server fails to respond, then the switch tries the next server in the list, and so-on. If none of the servers respond, then the switch attempts to use the secondary authentication method configured for the type of access being attempted (console, Telnet, or SSH). If this occurs, refer to "RADIUS-Related Problems" in the Troubleshooting chapter of the Management and Configuration Guide for your switch.

For example, suppose that your switch is configured to use three RADIUS servers for authenticating access through Telnet and SSH. Two of these servers use the same encryption key. In this case your plan is to configure the switch with the following global authentication parameters:

- Allow only two tries to correctly enter username and password.
- Use the global encryption key to support the two servers that use the same key. (For this example, assume that you did not configure these two servers with a server-specific key.)
- Use a dead-time of five minutes for a server that fails to respond to an authentication request.
- Allow three seconds for request timeouts.
- Allow two retries following a request that did not receive a response.

```
HPswitch (config)# aaa authentication num-attempts 2
HPswitch (config)# radius-server key My-Global-Key-1099
HPswitch (config)# radius-server dead-time 5
HPswitch (config)# radius-server timeout 3
HPswitch (config)# radius-server retransmit 2
HPswitch (config)# write mem
```

Figure 3-5. Example of Global Configuration Exercise for RADIUS Authentication

```
HPswitch> show authentication
Status and Counters - Authentication Information
Login Attempts : 2
-----+-----
Access Task | Login      Login      Enable     Enable
              | Primary    Secondary  Primary    Secondary
-----+-----
Console     | Local      None       Local      None
Telnet      | Radius     Local      Radius     Local
Port-Access | Local
SSH         | Radius     Local      Radius     Local

HPswitch> show radius
Status and Counters - General RADIUS Information
Deadtme (min) : 5
Timeout (secs) : 3
Retransmit Attempts : 2
Global Encryption Key : My-Global-Key-1099

Server IP Addr  Auth  Acct
                Port  Port  Encryption Key
-----+-----
10.33.18.127   1812 1813  source0127
10.33.18.119   1812 1813
10.33.18.151   1812 1813
```

After two attempts failing due to username or password entry errors, the switch will terminate the session.

Global RADIUS parameters from figure 3-5.

Server-specific encryption key for the RADIUS server that will not use the global encryption key.

These two servers will use the global encryption key.

Figure 3-6. Listings of Global RADIUS Parameters Configured In Figure 3-5

Local Authentication Process

When the switch is configured to use RADIUS, it reverts to local authentication only if one of these two conditions exists:

- "Local" is the authentication option for the access method being used.
- The switch has been configured to query one or more RADIUS servers for a primary authentication request, but has not received a response, and local is the configured secondary option.

For local authentication, the switch uses the Operator-level and Manager-level username/password set(s) previously configured locally on the switch. (These are the usernames and passwords you can configure using the CLI password command, the web browser interface, or the menu interface—which enables only local password configuration).

- If the operator at the requesting terminal correctly enters the username/password pair for either access level (Operator or Manager), access is granted on the basis of which username/password pair was used. For example, suppose you configure Telnet primary access for RADIUS and Telnet secondary access for local. If a RADIUS access attempt fails, then you can still get access to either the Operator or Manager level of the switch by entering the correct username/password pair for the level you want to enter.
- If the username/password pair entered at the requesting terminal does not match either local username/password pair previously configured in the switch, access is denied. In this case, the terminal is again prompted to enter a username/password pair. In the default configuration, the switch allows up to three attempts. If the requesting terminal exhausts the attempt limit without a successful authentication, the login session is terminated and the operator at the requesting terminal must initiate a new session before trying again.

Controlling Web Browser Interface Access When Using RADIUS Authentication

Configuring the switch for RADIUS authentication does not affect web browser interface access. To prevent unauthorized access through the web browser interface, do one or more of the following:

- Configure local authentication (a Manager user name and password and, optionally, an Operator user name and password) on the switch.
- Configure the switch's Authorized IP Manager feature to allow web browser access only from authorized management stations. (The Authorized IP Manager feature does not interfere with TACACS+ operation.)
- Disable web browser access to the switch.

Configuring RADIUS Accounting

RADIUS Accounting Commands	Page
[no] radius-server host < ip-address >	3-19
[acct-port < port-number >]	3-19
[key < key-string >]	3-19
[no] aaa accounting < exec network system > < start-stop stop-only > radius	3-21
[no] aaa accounting update periodic < 1 .. 525600 > (in minutes)	3-22
[no] aaa accounting suppress null-username	3-22
show accounting	3-26
show accounting sessions	3-27
show radius accounting	3-26

Note

This section assumes you have already:

- Configured RADIUS authentication on the switch for one or more access methods
- Configured one or more RADIUS servers to support the switch

If you have not already done so, refer to “General RADIUS Setup Procedure” on page 3-5 before continuing here.

RADIUS accounting collects data about user activity and system events and sends it to a RADIUS server when specified events occur on the switch, such as a logoff or a reboot. The Series 4100GL switches support three types of accounting services:

- **Network accounting:** Provides records containing the information listed below on clients directly connected to the switch and operating under Port-Based Access Control (802.1x):

- Acct-Session-Id
- Acct-Delay-Time
- Nas-Port
- Service-Type
- Acct-Status-Type
- Acct-Input-Packets
- Acct-Output-Octets
- NAS-IP-Address
- Acct-Terminate-Cause
- Acct-Output-Packets
- Acct-Session-Time
- NAS-Identifier
- Acct-Authentic
- Acct-Input-Octets
- Username
- Called-Station-Id

(For 802.1x information for the switch, refer to “Configuring Port-Based Access Control (802.1x)” on page 5-1.)

- **Exec accounting:** Provides records containing the information listed below about login sessions (console, Telnet, and SSH) on the switch:

- Acct-Session-Id
- Acct-Delay-Time
- NAS-IP-Address
- Acct-Status-Type
- Acct-Session-Time
- NAS-Identifier
- Acct-Terminate-Cause
- Username
- Calling-Station-Id
- Acct-Authentic
- Service-Type

- **System accounting:** Provides records containing the information listed below when system events occur on the switch, including system reset, system boot, and enabling or disabling of system accounting.

- Acct-Session-Id
- Acct-Delay-Time
- NAS-Identifier
- Acct-Status-Type
- Username
- Calling-Station-Id
- Acct-Terminate-Cause
- Service-Type
- Acct-Authentic
- NAS-IP-Address

The switch forwards the accounting information it collects to the designated RADIUS server, where the information is formatted, stored, and managed by the server. For more information on this aspect of RADIUS accounting, refer to the documentation provided with your RADIUS server.

Operating Rules for RADIUS Accounting

- You can configure up to three types of accounting to run simultaneously: exec, system, and network.
- RADIUS servers used for accounting are also used for authentication.
- The switch must be configured to access at least one RADIUS server.
- RADIUS servers are accessed in the order in which their IP addresses were configured in the switch. Use **show radius** to view the order. As long as the first server is accessible and responding to authentication requests from the switch, a second or third server will not be accessed. (For more on this topic, refer to “Changing RADIUS-Server Access Order” on page 3-27.)

- If access to a RADIUS server fails during a session, but after the client has been authenticated, the switch continues to assume the server is available to receive accounting data. Thus, if server access fails during a session, it will not receive accounting data transmitted from the switch.

Steps for Configuring RADIUS Accounting

1. Configure the switch for accessing a RADIUS server.

You can configure a list of up to three RADIUS servers (one primary, two backup). The switch operates on the assumption that a server can operate in both accounting and authentication mode. (Refer to the documentation for your RADIUS server application.)

- Use the same **radius-server host** command that you would use to configure RADIUS authentication. Refer to “2. Configure the Switch To Access a RADIUS Server” on page 3-10.
 - Provide the following:
 - A RADIUS server IP address.
 - Optional—a UDP destination port for authentication requests. Otherwise the switch assigns the default UDP port (1812; recommended).
 - Optional—if you are also configuring the switch for RADIUS authentication, and need a unique encryption key for use during authentication sessions with the RADIUS server you are designating, configure a server-specific key. This key overrides the global encryption key you can also configure on the switch, and must match the encryption key used on the specified RADIUS server. For more information, refer to the “[**key < key-string >**]” parameter on page 3-10. (Default: null)
2. Configure accounting types and the controls for sending reports to the RADIUS server.
 - **Accounting types:** exec (page 3-17), network (page 3-16), or system (page 3-17)
 - **Trigger for sending accounting reports to a RADIUS server:** At session start and stop or only at session stop
 3. (Optional) Configure session blocking and interim updating options
 - **Updating:** Periodically update the accounting data for sessions-in-progress
 - **Suppress accounting:** Block the accounting session for any unknown user with no username access to the switch

1. Configure the Switch To Access a RADIUS Server

Before you configure the actual accounting parameters, you should first configure the switch to use a RADIUS server. This is the same as the process described on page 3-10. You need to repeat this step here only if you have not yet configured the switch to use a RADIUS server, your server data has changed, or you need to specify a non-default UDP destination port for accounting requests. Note that switch operation expects a RADIUS server to accommodate both authentication and accounting.

Syntax: [no] radius-server host < ip-address >

*Adds a server to the RADIUS configuration or (with **no**) deletes a server from the configuration.*

[acct-port < port-number >]

Optional. Changes the UDP destination port for accounting requests to the specified RADIUS server. If you do not use this option, the switch automatically assigns the default accounting port number. (Default: 1813)

[key < key-string >]

Optional. Specifies an encryption key for use during accounting or authentication sessions with the specified server. This key must match the encryption key used on the RADIUS server. Use this command only if the specified server requires a different encryption key than configured for the global encryption key.

(For a more complete description of the **radius-server** command and its options, turn to page 3-10.)

For example, suppose you want the switch to use the RADIUS server described below for both authentication and accounting purposes.

- IP address: 10.33.18.151
- A non-default UDP port number of 1750 for accounting.

For this example, assume that all other RADIUS authentication parameters for accessing this server are acceptable at their default settings, and that RADIUS is already configured as an authentication method for one or more types of access to the switch (Telnet, Console, etc.).

```
HPswitch(config)# radius-server host 10.33.18.151 acct-port 1750 key source0151
HPswitch(config)# write mem
HPswitch(config)# show radius
Status and Counters - General RADIUS Information
  Deadtime(min) : 5
  Timeout(secs) : 3
  Retransmit Attempts : 2
  Global Encryption Key :

  Server IP Addr      Auth Port  Acct Port  Encryption Key
  -----
  10.33.18.151      1812     1750     source0151
```

Because the radius-server command includes an **acct-port** element with a non-default 1750, the switch assigns this value to the accounting port UDP port numbers. Because auth-port was not included in the command, the authentication UDP port is set to the default 1812.

Figure 3-7. Example of Configuring for a RADIUS Server with a Non-Default Accounting UDP Port Number

The radius-server command as shown in figure 3-7, above, configures the switch to use a RADIUS server at IP address 10.33.18.151, with a (non-default) UDP accounting port of 1750, and a server-specific key of "source0151".

2. Configure Accounting Types and the Controls for Sending Reports to the RADIUS Server

Select the Accounting Type(s):

- **Exec:** Use **exec** if you want to collect accounting information on login sessions on the switch via the console, Telnet, or SSH. (See also “Accounting” on page 3-2.)
- **System:** Use **system** if you want to collect accounting data when:
 - A system boot or reload occurs
 - System accounting is turned on or off

Note that there is no timespan associated with using the **system** option. It simply causes the switch to transmit whatever accounting data it currently has when one of the above events occurs.

- **Network:** Use **Network** if you want to collect accounting information on 802.1x port-based-access users connected to the physical ports on the switch to access the network. (See also “Accounting” on page 2.) For information on this feature, refer to “Configuring Port-Based Access Control (802.1x)” on page 5-1.

Determine how you want the switch to send accounting data to a RADIUS server:

■ **Start-Stop:**

- Send a start record accounting notice at the beginning of the accounting session and a stop record notice at the end of the session. Both notices include the latest data the switch has collected for the requested accounting type (Network, Exec, or System).
- Do not wait for an acknowledgement.

The system option (page 3-20) ignores **start-stop** because the switch sends the accumulated data only when there is a reboot, reload, or accounting on/off event.

■ **Stop-Only:**

- Send a stop record accounting notice at the end of the accounting session. The notice includes the latest data the switch has collected for the requested accounting type (Network, Exec, or System).
- Do not wait for an acknowledgement.

The system option (page 3-20) always delivers **stop-only** operation because the switch sends the accumulated data only when there is a reboot, reload, or accounting on/off event.

Syntax: [no] aaa accounting < exec | network | system > < start-stop | stop-only > radius

Configures RADIUS accounting type and how data will be sent to the RADIUS server.

For example, to configure RADIUS accounting on the switch with **start-stop** for exec functions and **stop-only** for system functions:

```

HPswitch(config)# aaa accounting exec start-stop radius
HPswitch(config)# aaa accounting system stop-only radius
HPswitch(config)# show accounting

```

Status and Counters - Accounting Information	
Interval(min) :	0
Suppress Empty User :	No
Type	Method Mode
----- + -----	
Network	None
Exec	Radius Start-Stop
System	Radius Stop-Only

The diagram shows three callout boxes with arrows pointing to specific parts of the configuration and output:

- Configures exec and system accounting and**: Points to the two configuration commands: `aaa accounting exec start-stop radius` and `aaa accounting system stop-only radius`.
- Summarizes the switch's accounting**: Points to the `show accounting` command and its output table.
- Exec and System accounting are active. (Assumes the switch is configured to access a reachable**: Points to the `Exec` and `System` rows in the output table.

Figure 3-8. Example of Configuring Accounting Types

3. (Optional) Configure Session Blocking and Interim Updating Options

These optional parameters give you additional control over accounting data.

- **Updates:** In addition to using a Start-Stop or Stop-Only trigger, you can optionally configure the switch to send periodic accounting record updates to a RADIUS server.
- **Suppress:** The switch can suppress accounting for an unknown user having no username.

Syntax: `[no] aaa accounting update periodic < 1 .. 525600 >` Sets the accounting update period

for all accounting sessions on the switch. (The **no** form disables the update function and resets the value to zero.) (Default: zero; disabled)

`[no] aaa accounting suppress null-username` Disables accounting for unknown

users having no username.
(Default: suppression disabled)

To continue the example in figure 3-8, suppose that you wanted the switch to:

- Send updates every 10 minutes on in-progress accounting sessions.
- Block accounting for unknown users (no username).

```
HPswitch(config)# aaa accounting update periodic 10
HPswitch(config)# aaa accounting suppress null-username

HPswitch(config)# show accounting
Status and Counters - Accounting Information
Interval(min) : 10
Suppress Empty User : Yes

Type      | Method Mode
-----+-----
Network  | None
Exec     | Radius Start-Stop
System   | Radius Stop-Only
```

Update Period

Suppress Unknown User

Figure 3-9. Example of Optional Accounting Update Period and Accounting Suppression on Unknown User

Viewing RADIUS Statistics

General RADIUS Statistics

Syntax: show radius [host < ip-addr >]

*Shows general RADIUS configuration, including the server IP addresses. Optional form shows data for a specific RADIUS host. To use **show radius**, the server's IP address must be configured in the switch, which requires prior use of the **radius-server host** command. (See "Configuring RADIUS Accounting" on page 3-16.)*

```

HPswitch(config)# show radius
Status and Counters - General RADIUS Information
  Deadttime(min) : 5
  Timeout(secs) : 10
  Retransmit Attempts : 2
  Global Encryption Key : myg10balkey

          Auth  Acct
Server IP Addr  Port  Port  Encryption Key
-----
192.33.12.65   1812 1813  my65key
  
```

Figure 3-10. Example of General RADIUS Information from Show Radius Command

```

HPswitch(config)# show radius host 192.33.12.65
Status and Counters - RADIUS Server Information
  Server IP Addr : 192.33.12.65
  Authentication UDP Port : 1812           Accounting UDP Port : 1813
  Round Trip Time      : 2                 Round Trip Time      : 7
  Pending Requests     : 0                 Pending Requests     : 0
  Retransmissions      : 0                 Retransmissions      : 0
  Timeouts             : 0                 Timeouts             : 0
  Malformed Responses  : 0                 Malformed Responses  : 0
  Bad Authenticators   : 0                 Bad Authenticators   : 0
  Unknown Types        : 0                 Unknown Types        : 0
  Packets Dropped      : 0                 Packets Dropped      : 0
  Access Requests      : 2                 Accounting Requests  : 2
  Access Challenges    : 0                 Accounting Responses : 2
  Access Accepts       : 2
  Access Rejects       : 0
  
```

Figure 3-11. RADIUS Server Information From the Show Radius Host Command

RADIUS Authentication and Accounting

Viewing RADIUS Statistics

Term	Definition
Round Trip Time	The time interval between the most recent Accounting-Response and the Accounting-Request that matched it from this RADIUS accounting server.
PendingRequests	The number of RADIUS Accounting-Request packets sent to this server that have not yet timed out or received a response. This variable is incremented when an accounting-Request is sent and decremented due to receipt of an Accounting-Response, a timeout or a retransmission.
Retransmissions	The number of RADIUS Accounting-Request packets retransmitted to this RADIUS accounting server. Retransmissions include retries where the Identifier and Acct-Delay have been updated, as well as those in which they remain the same.
Timeouts	The number of accounting timeouts to this server. After a timeout the client may retry to the same server, send to a different server, or give up. A retry to the same server is counted as a retransmit as well as a timeout. A send to a different server is counted as an Accounting-Request as well as a timeout.
Malformed Responses	The number of malformed RADIUS Accounting-Response packets received from this server. Malformed packets include packets with an invalid length. Bad authenticators and unknown types are not included as malformed accounting responses.
Bad Authenticators	The number of RADIUS Accounting-Response packets which contained invalid authenticators received from this server.
Unknown Types	The number of RADIUS packets of unknown type which were received from this server on the accounting port.
Packets Dropped	The number of RADIUS packets which were received from this server on the accounting port and dropped for some other reason.
Requests	The number of RADIUS Accounting-Request packets sent. This does not include retransmissions.
AccessChallenges	The number of RADIUS Access-Challenge packets (valid or invalid) received from this server.
AccessAccepts	The number of RADIUS Access-Accept packets (valid or invalid) received from this server.
AccessRejects	The number of RADIUS Access-Reject packets (valid or invalid) received from this server.
Responses	The number of RADIUS packets received on the accounting port from this server.

RADIUS Authentication Statistics

Syntax: show authentication

Displays the primary and secondary authentication methods configured for the Console, Telnet, Port-Access (802.1x), and SSH methods of accessing the switch. Also displays the number of access attempts currently allowed in a session.

show radius authentication

*Displays NAS identifier and data on the configured RADIUS server and the switch's interactions with this server. (Requires prior use of the **radius-server host** command to configure a RADIUS server IP address in the switch. See "Configuring RADIUS Accounting" on page 3-16.)*

```
HPswitch> show authentication
Status and Counters - Authentication Information
Login Attempts : 2
```

Access Task	Login Primary	Login Secondary	Enable Primary	Enable Secondary
Console	Local	None	Local	None
Telnet	Radius	Local	Radius	Local
Port-Access	Local			
SSH	Radius	Local	Radius	Local

Figure 3-12. Example of Login Attempt and Primary/Secondary Authentication Information from the Show Authentication Command

```
HPswitch(config)# show radius authentication
Status and Counters - RADIUS Authentication Information
NAS Identifier : HPswitch
Invalid Server Addresses : 0
```

Server IP Addr	UDP Port	Timeouts	Requests	Challenges	Accepts	Rejects
192.33.12.65	1812	0	2	0	2	0

Figure 3-13. Example of RADIUS Authentication Information from a Specific Server

RADIUS Accounting Statistics

Syntax: show accounting

Lists configured accounting interval, "Empty User" suppression status, accounting types, methods, and modes.

show radius accounting

*Lists accounting statistics for the RADIUS server(s) configured in the switch (using the **radius-server host** command).*

show accounting sessions

Lists the accounting sessions currently active on the switch.

```
HPswitch # show accounting

Status and Counters - Accounting Information

Interval(min) : 5
Suppress Empty User : Yes

Type      | Method Mode
-----+-----
Network  | None
Exec     | Radius Start-Stop
System   | Radius Stop-Only
```

Figure 3-14. Listing the Accounting Configuration in the Switch

```
HPswitch # show radius accounting
Status and Counters - RADIUS Accounting Information
NAS Identifier : HPswitch
Invalid Server Addresses : 0

          UDP
Server IP Addr  Port  Timeouts  Requests  Responses
-----
192.33.12.65   1813  0         1         1
```

Figure 3-15. Example of RADIUS Accounting Information for a Specific Server

```
HPswitch # show accounting sessions  
  
Active Accounted actions on CONSOLE, User radius Priv 2,  
Session ID 1, EXEC Accounting record, 00:02:32 Elapsed
```

Figure 3-16. Example Listing of Active RADIUS Accounting Sessions on the Switch

Changing RADIUS-Server Access Order

The switch tries to access RADIUS servers according to the order in which their IP addresses are listed by the **show radius** command. Also, *when you add a new server IP address, it is placed in the highest empty position in the list.*

Adding or deleting a RADIUS server IP address leaves an empty position, but does not change the position of any other server addresses in the list. For example if you initially configure three server addresses, they are listed in the order in which you entered them. However, if you subsequently remove the second server address in the list and add a new server address, the new address will be placed second in the list.

Thus, to move a server address up in the list, you must delete it from the list, ensure that the position to which you want to move it is vacant, and then re-enter it. For example, suppose you have already configured the following three RADIUS server IP addresses in the switch:

```
HPswitch # show radius  
Status and Counters - General RADIUS Information  
Deadtime (min) : 0  
Timeout (secs) : 5  
Retransmit Attempts : 3  
Global Encryption Key :  
  
Server IP Addr  Auth  Acct  
                Port  Port  Encryption Key  
-----  
10.10.10.1      1812 1813  
10.10.10.2      1812 1813  
10.10.10.3      1812 1813
```

RADIUS server IP addresses listed in the order in which the switch will try to access them. In this case, the server at IP address 1.1.1.1 is first.

Note: If the switch successfully accesses the first server, it does not try to access any other servers in the list, even if the client is denied access by the first server.

Figure 3-17. Search Order for Accessing a RADIUS Server

To exchange the positions of the addresses so that the server at 10.10.10.003 will be the first choice and the server at 10.10.10.001 will be the last, you would do the following:

1. Delete 10.10.10.003 from the list. This opens the third (lowest) position in the list.
2. Delete 10.10.10.001 from the list. This opens the first (highest) position in the list.
3. Re-enter 10.10.10.003. Because the switch places a newly entered address in the highest-available position, this address becomes first in the list.
4. Re-enter 10.10.10.001. Because the only position open is the third position, this address becomes last in the list.

```
HPswitch(config)# no radius host 10.10.10.003
HPswitch(config)# no radius host 10.10.10.001
HPswitch(config)# radius host 10.10.10.003
HPswitch(config)# radius host 10.10.10.001
HPswitch(config)# show radius
```

Status and Counters - General RADIUS Information

```
Deadtime(min) : 0
Timeout(secs) : 5
Retransmit Attempts : 3
Global Encryption Key :
```

Server IP Addr	Auth Port	Acct Port	Encryption Key
10.10.10.3	1812	1813	
10.10.10.2	1812	1813	
10.10.10.1	1812	1813	

Removes the "003" and "001" addresses from the RADIUS server list.

Inserts the "003" address in the first position in the RADIUS server list, and inserts the "001" address in the last position in the list.

Shows the new order in which the switch searches for a RADIUS server.

Figure 3-18. Example of New RADIUS Server Search Order

Messages Related to RADIUS Operation

Message	Meaning
Can't reach RADIUS server < x.x.x.x >.	A designated RADIUS server is not responding to an authentication request. Try pinging the server to determine whether it is accessible to the switch. If the server is accessible, then verify that the switch is using the correct encryption key and that the server is correctly configured to receive an authentication request from the switch.
No server(s) responding.	The switch is configured for and attempting RADIUS authentication, however it is not receiving a response from a RADIUS server. Ensure that the switch is configured to access at least one RADIUS server. (Use show radius .) If you also see the message Can't reach RADIUS server < x.x.x.x >, try the suggestions listed for that message.
Not legal combination of authentication methods.	Indicates an attempt to configure local as both the primary and secondary authentication methods. If local is the primary method, then none must be the secondary method.

RADIUS Authentication and Accounting
Messages Related to RADIUS Operation

Configuring Secure Shell (SSH)

Contents

Overview	4-2
Terminology	4-4
Prerequisite for Using SSH	4-5
Public Key Format Requirement	4-5
Steps for Configuring and Using SSH for Switch and Client Authentication	4-6
General Operating Rules and Notes	4-8
Configuring the Switch for SSH Operation	4-9
1. Assigning a Local Login (Operator) and Enable (Manager) Password	4-9
2. Generating the Switch's Public and Private Key Pair	4-10
3. Providing the Switch's Public Key to Clients	4-12
4. Enabling SSH on the Switch and Anticipating SSH Client Contact Behavior	4-15
5. Configuring the Switch for SSH Authentication	4-18
6. Use an SSH Client To Access the Switch	4-21
Further Information on SSH Client Public-Key Authentication	4-21
Messages Related to SSH Operation	4-26

Overview

Feature	Default	Menu	CLI	Web
Generating a public/private key pair on the switch	No	n/a	page 4-10	n/a
Using the switch's public key	n/a	n/a	page 4-12	n/a
Enabling SSH	Disabled	n/a	page 4-15	n/a
Enabling client public-key authentication	Disabled	n/a	pages 4-18, 4-21	n/a
Enabling user authentication	Disabled	n/a	page 4-18	n/a

The Series 4100GL switches use Secure Shell version 1 (SSHv1) to provide remote access to management functions on the switches via encrypted paths between the switch and management station clients capable of SSHv1 operation. (The switches can be authenticated by SSHv2 clients that support SSHv1.) However, to use the reverse option—authenticating an SSHv2 user to the switch—you must have a method for converting the SSHv2 PEM public-key format to non-encoded ASCII. Refer to "PEM: (Privacy Enhanced Mode" on page 4-4.)

SSH provides Telnet-like functions but, unlike Telnet, SSH provides encrypted, authenticated transactions. The authentication types include:

- Client public-key authentication
- Switch SSH and user password authentication

Client Public Key Authentication (Login/Operator Level) with User Password Authentication (Enable/Manager Level). This option uses one or more public keys (from clients) that must be stored on the switch. Only a client with a private key that matches a stored public key can gain access to the switch. (The same private key can be stored on one or more clients.)

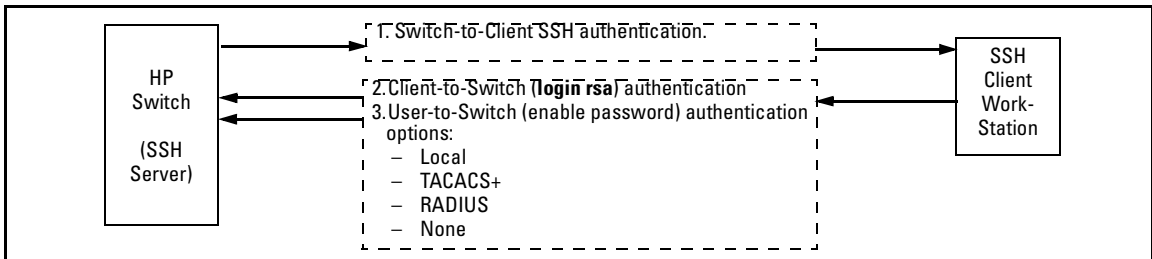

Figure 4-1. Client Public Key Authentication Model

Note

SSH in the HP Procurve Series 4100GL switches is based on the OpenSSH software toolkit. For more information on OpenSSH, visit <http://www.openssh.com>.

Switch SSH and User Password Authentication . This option is a subset of the client public-key authentication show in figure 4-1. It occurs if the switch has SSH enabled but does not have login access (**login rsa**) configured to authenticate the client's key. As in figure 4-1, the switch authenticates itself to SSH clients. Users on SSH clients then authenticate themselves to the switch (login and/or enable levels) by providing passwords stored locally on the switch or on a TACACS+ or RADIUS server. However, the client does not use a key to authenticate itself to the switch.

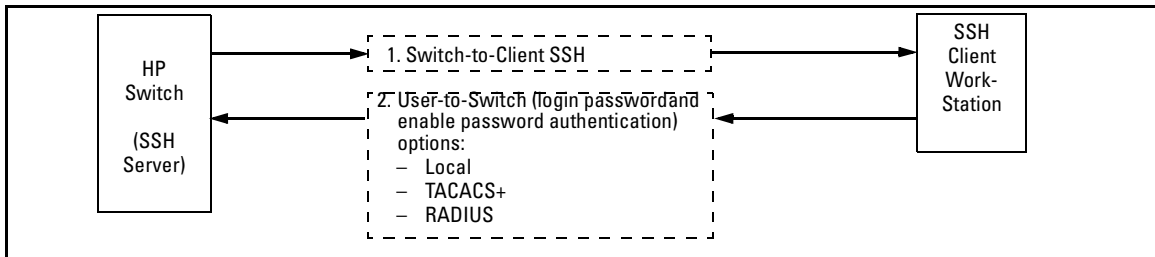

Figure 4-2. Switch/User Authentication

SSH on the Series 4100GL switches supports these data encryption methods:

- 3DES (168-bit)
- DES (56-bit)

Note

This release supports SSH version 1 only, and all references to SSH in this document are to SSHv1 unless otherwise stated. SSH version 1 uses RSA public key algorithms exclusively, and all references to either a public or private key mean keys generated using these algorithms unless otherwise noted.

Terminology

- **SSH Server:** An HP switch with SSH enabled.
- **Key Pair:** A pair of keys generated by the switch or an SSH client application. Each pair includes a public key (that can be read by anyone) and a private key that is held internally in the switch or by a client.
- **PEM (Privacy Enhanced Mode):** Refers to an ASCII-formatted client public-key that has been encoded for greater security. SSHv2 client public-keys are typically stored in the PEM format. See figures 4-3 and 4-4 for examples of PEM-encoded ASCII and non-encoded ASCII keys.
- **Private Key:** An internally generated key used in the authentication process. A private key generated by the switch is not accessible for viewing or copying. A private key generated by an SSH client application is typically stored in a file on the client device and, together with its public key counterpart, can be copied and stored on multiple devices.
- **Public Key:** An internally generated counterpart to a private key. A device's public key is used to authenticate the device to other devices.
- **Enable Level:** Manager privileges on the switch.
- **Login Level:** Operator privileges on the switch.
- **Local password or username:** A Manager-level or Operator-level password configured in the switch.
- **SSH Enabled:** (1) A public/private key pair has been generated on the switch (**crypto key generate [rsa]**) and (2) SSH is enabled (**ip ssh**). (You can generate a key pair without enabling SSH, but you cannot enable SSH without first generating a key pair. See “2. Generating the Switch's Public and Private Key Pair” on page 4-10 and “4. Enabling SSH on the Switch and Anticipating SSH Client Contact Behavior” on page 4-15.)

Prerequisite for Using SSH

Before using the switch as an SSH server, you must install a publicly or commercially available SSH client application on the computer(s) you use for management access to the switch. If you want client public-key authentication (page 4-2), then the client program must have the capability to generate public and private key pairs.

Public Key Format Requirement

Any client application you use for client public-key authentication with the switch must have the capability to store a public key in non-encoded ASCII format. The switch does not interpret keys generated using the PEM (Privacy Enhanced Mode) format (also in ASCII characters) that some SSHv2 client applications use for storing public keys. If your client application stores PEM-encoded keys by default, check the application software for a key conversion utility or use a third-party key conversion utility.

```
"Pub Key Gen 21 Dec 2001 12:01"A1B3Nz1y2+orEhYL . . . Q8D8qDM1ozu1c="*** End of Pub Key ***"
```

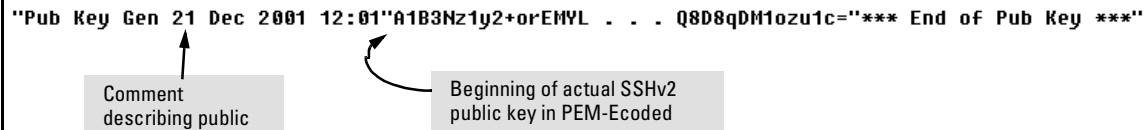

Figure 4-3. Example of Public Key in PEM-Encoded ASCII Format Common for SSHv2 Clients

```
512 37 78193303392019545793321845914508115859448079486918367079008218589443776362026267. . .
```

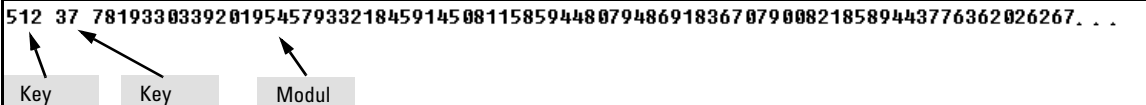

Figure 4-4. Example of Public Key in Non-Encoded ASCII Format (Common for SSHv1 Client Applications)

Steps for Configuring and Using SSH for Switch and Client Authentication

For two-way authentication between the switch and an SSH client, you must use the login (Operator) level.

Table 4-5. SSH Options

Switch Access Level	Primary SSH Authentication	Authenticate Switch Public Key to SSH Clients?	Authenticate Client Public Key to the Switch?	Primary Switch Password Authentication	Secondary Switch Password Authentication
Operator (Login) Level	ssh login rsa	Yes	Yes ¹	No ¹	local or none
	ssh login Local	Yes	No	Yes	local or none
	ssh login TACACS	Yes	No	Yes	local or none
	ssh login RADIUS	Yes	No	Yes	local or none
Manager (Enable) Level	ssh enable local	Yes	No	Yes	local or none
	ssh enable tacacs	Yes	No	Yes	local or none
	ssh enable radius	Yes	No	Yes	local or none

¹ For **ssh login rsa**, the switch uses client public-key authentication instead of the switch password options for primary authentication.

The general steps for configuring SSH include:

A. Client Preparation

1. Install an SSH client application on a management station you want to use for access to the switch. (Refer to the documentation provided with your SSH client application.)
2. Optional—If you want the switch to authenticate a client public-key on the client:
 - a. Either generate a public/private key pair on the client computer or (if your client application allows) or import a client key pair that you have generated using another SSH application.
 - b. Copy the client public key into an ASCII file on a TFTP server accessible to the switch and download the client public key file to the switch. (The client public key file can hold up to 10 client keys.) This topic is covered under “To Create a Client-Public-Key Text File” on page 4-23.

B. Switch Preparation

1. Assign a login (Operator) and enable (Manager) password on the switch (page 4-9).
2. Generate a public/private key pair on the switch (page 4-10).

You need to do this only once. The key remains in the switch even if you reset the switch to its factory-default configuration. (You can remove or replace this key pair, if necessary.)
3. Copy the switch's public key to the SSH clients you want to access the switch (page 4-12).
4. Enable SSH on the switch (page 4-15).
5. Configure the primary and secondary authentication methods you want the switch to use. In all cases, the switch will use its host-public-key to authenticate itself when initiating an SSH session with a client.
 - SSH Login (Operator) options:
 - Option A:

Primary: Local, TACACS+, or RADIUS password
Secondary: Local password or none
 - Option B:

Primary: Client public-key authentication (**login rsa** — page 4-21)
Secondary: Local password or none

Note that if you want the switch to perform client public-key authentication, you must configure the switch with Option B.
 - SSH Enable (Manager) options:

Primary: Local, TACACS+, or RADIUS
Secondary: Local password or none
6. Use your SSH client to access the switch using the switch's IP address or DNS name (if allowed by your SSH client application). Refer to the documentation provided with the client application.

General Operating Rules and Notes

- Any SSH client application you use must offer backwards-compatibility to SSHv1 keys and operation.
- Public keys generated on an SSH client computer must be in ASCII format (used in SSHv1) if you want to be able to authenticate a client to the switch. The switch does not support keys generated in the PEM (base-64 Privacy Enhanced Mode) format. See the Note under “Prerequisite for Using SSH” on page 4-5.
- The switch’s own public/private key pair and the (optional) client public key file are stored in the switch’s flash memory and are not affected by reboots or the **erase startup-config** command.
- Once you generate a key pair on the switch you should avoid re-generating the key pair without a compelling reason. Otherwise, you will have to re-introduce the switch’s public key on all management stations (clients) you previously set up for SSH access to the switch. In some situations this can temporarily allow security breaches.
- When stacking is enabled, SSH provides security only between an SSH client and the stack manager. Communications between the stack commander and stack members is not secure.
- The switch does not support outbound SSH sessions. Thus, if you Telnet from an SSH-secure switch to another SSH-secure switch, *the session is not secure.*

Configuring the Switch for SSH Operation

SSH-Related Commands in This Section	Page
show ip ssh	4-17
show ip client-public-key [< babble fingerprint >]	4-24
show ip host-public-key [< babble fingerprint >]	4-14
show authentication	4-20
crypto key < generate zeroize > [rsa]	4-11
ip ssh	4-16
key-size < 512 768 1024 >	4-16
port < 1 - 65535 >	4-16
timeout < 5 .. 120 >	4-16
aaa authentication ssh	
login < local tacacs radius rsa >	4-18, 4-19
< local none >	4-18
enable < tacacs radius local >	4-18
< local none >	4-18
copy tftp pub-key-file <tftp server IP> <public key file>	4-24
clear public key	4-25

1. Assigning a Local Login (Operator) and Enable (Manager) Password

At a minimum, HP recommends that you always assign at least a Manager password to the switch. Otherwise, under some circumstances, anyone with Telnet, web, or serial port access could modify the switch's configuration.

To Configure Local Passwords. You can configure both the Operator and Manager password with one command.

Syntax: password < manager | operator | all >

```
HPswitch(config)# password all
New password for Operator: *****
Please retype new password for Operator: *****
New password for Manager: *****
Please retype new password for Manager: *****
HPswitch(config)#
```

Figure 4-6. Example of Configuring Local Passwords

2. Generating the Switch's Public and Private Key Pair

You must generate a public and private host key pair on the switch. The switch uses this key pair, along with a dynamically generated session key pair to negotiate an encryption method and session with an SSH client trying to connect to the switch.

The host key pair is stored in the switch's flash memory, and only the public key in this pair is readable. The public key should be added to a "known hosts" file (for example, `$HOME/.ssh/known_hosts` on UNIX systems) on the SSH clients who you want to have access to the switch. Some SSH client applications automatically add the the switch's public key to a "known hosts" file. Other SSH applications require you to manually create a known hosts file and place the switch's public key in the file. (Refer to the documentation for your SSH client application.)

(The session key pair mentioned above is not visible on the switch. It is a temporary, internally generated pair used for a particular switch/client session, and then discarded.)

Notes

When you generate a host key pair on the switch, the switch places the key pair in flash memory (and not in the running-config file). Also, the switch maintains the key pair across reboots, including power cycles. You should consider this key pair to be "permanent"; that is, avoid re-generating the key pair without a compelling reason. Otherwise, you will have to re-introduce the switch's public key on all management stations you have set up for SSH access to the switch using the earlier pair.

Removing (zeroizing) the switch's public/private key pair renders the switch unable to engage in SSH operation and automatically disables IP SSH on the switch. (To verify whether SSH is enabled, execute **show ip ssh**.)

To Generate or Erase the Switch's Public/Private RSA Host Key Pair.

Because the host key pair is stored in flash instead of the running-config file, it is not necessary to use **write memory** to save the key pair. Erasing the key pair automatically disables SSH.

Syntax: `crypto key generate [rsa]`

Generates a public/private key pair for the switch. If a switch key pair already exists, replaces it with a new key pair. (See the Note, above.)

`crypto key zeroize [rsa]`

Erases the switch's public/private key pair and disables SSH operation..

`show ip ssh host-public-key`

Displays switch's public key as an ASCII string.

[babble]

Displays a hash of the switch's public key in phonetic format. (See "Displaying the Public Key" on page 4-14.)

[fingerprint]

Displays a "fingerprint" of the switch's public key in hexadecimal format. (See "Displaying the Public Key" on page 4-14.)

For example, to generate and display a new key:

```
HPswitch(config)# crypto key generate rsa
Generating new RSA host key.  If the cache is depleted,
this could take up to two minutes.
HPswitch(config)# show ip host-public-key
896 35 4271994707660774263666250605799242148515279332487520218551264932934075407
04782860432930458032140273304999167004670769854352973485302001767770553555445568
80992231580238056056245444224389955500310200336191361046978602009243623264937429
406062777506601747146563337525446401
```

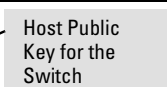

Figure 4-7. Example of Generating a Public/Private Host Key Pair for the Switch

Notes

"Zeroizing" the switch's key automatically disables SSH (sets **IP SSH** to **No**). Thus, if you zeroize the key and then generate a new key, you must also re-enable SSH with the **ip ssh** command before the switch can resume SSH operation.

3. Providing the Switch's Public Key to Clients

When an SSH client contacts the switch for the first time, the client will challenge the connection unless you have already copied the key into the client's "known host" file. Copying the switch's key in this way reduces the chance that an unauthorized device can pose as the switch to learn your access passwords. The most secure way to acquire the switch's public key for distribution to clients is to use a direct, serial connection between the switch and a management device (laptop, PC, or UNIX workstation), as described below.

Note on the Public Key Format

The switch uses SSH version 1, but can be authenticated by SSH version 2 clients that are backwards-compatible to SSHv1. However, if your SSH client supports SSHv2, then it may use the PEM format for storing the switch's public key in its "known host" file. In this case, the following procedure will not work for the client unless you have a method for converting the switch's ASCII-string public key into the PEM format. If you do not have a conversion method, then you can still set up authentication of the switch to the client over the network by simply using your client to contact the switch and then accepting the resulting challenge that your client should pose to accepting the switch. This should be acceptable as long as you are confident that there is no "man-in-the-middle" spoofing attempt during the first contact. Because the client will acquire the switch's public key after you accept the challenge, subsequent contacts between the client and the switch should be secure.

The public key generated by the switch consists of three parts, separated by one blank space each:

```
      K      Encoded      Encode
      e      Public      d
      ↓      ↙          ↓
896 35 427199470766077426366625060579924214851527933248752021855126493
2934075407047828604329304580321402733049991670046707698543529734853020
0176777055355544556880992231580238056056245444224389955500310200336191
3610469786020092436232649374294060627777506601747146563337525446401
```

Figure 4-8. Example of a Public Key Generated by the Switch

(The generated public key on the switch is always 896 bits.)

With a direct serial connection from a management station to the switch:

1. Use a terminal application such as HyperTerminal to display the switch's public key with the **show ip host-public-key** command (figure 4-7).
2. Bring up the SSH client's "known host" file in a text editor such as Notepad as straight ASCII text, and copy the switch's public key into the file.
3. Ensure that there are no line breaks in the text string. (A public key must be an unbroken ASCII string. Line breaks are not allowed.) For example, if you are using Windows® Notepad, ensure that **Word Wrap** (in the **Edit** menu) is disabled, and that the key text appears on a single line.

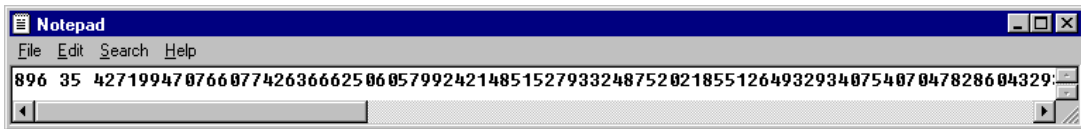

Figure 4-9. Example of a Correctly Formatted Public Key (Unbroken ASCII String)

4. Add any data required by your SSH client application. For example Before saving the key to an SSH client's "known hosts" file you may have to insert the switch's IP address:

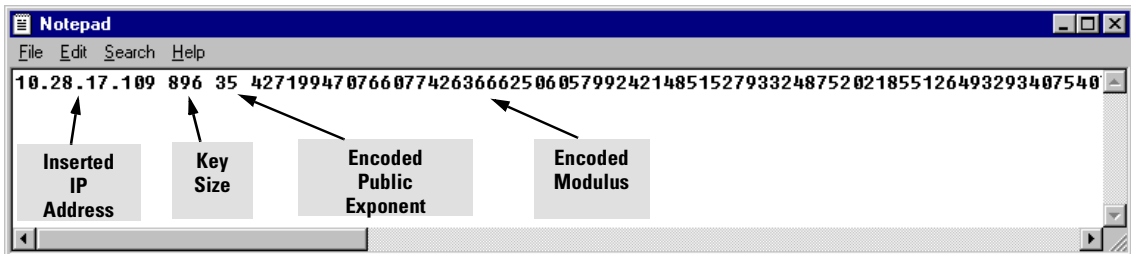

Figure 4-10. Example of a Switch Public Key Edited To Include the Switch's IP Address

For more on this topic, refer to the documentation provided with your SSH client application.

Displaying the Public Key. The switch provides three options for displaying its public key. This is helpful if you need to visually verify that the public key the switch is using for authenticating itself to a client matches the copy of this key in the client's "known hosts" file:

- **Non-encoded ASCII numeric string:** Requires a client ability to display the keys in the "known hosts" file in the ASCII format. This method is tedious and error-prone due to the large ASCII number set. (See figure 4-9 on page 4-13.)
- **Phonetic hash:** Outputs the key as a relatively short series of alphabetic character groups. Requires a client ability to convert the key to this format.
- **Hexadecimal hash:** Outputs the key as a relatively short series of hexadecimal numbers. Requires a parallel client ability.

For example, on the switch, you would generate the phonetic and hexadecimal versions of the switch's public key in figure 4-9 as follows:

```
HPswitch# show ip host-public-key babble
896 xurac-metym-sagaf-recus-caleb-niten-kames-pobud-poluc-gelyl-exxsa

HPswitch# show ip host-public-key fingerprint
896 f3:f3:61:4c:06:ea:53:c2:7f:e7:78:b6:9b:7f:88:5b
```

Figure 4-11. Examples of Visual Phonetic and Hexadecimal Conversions of the Switch's Public Key

Note

The two commands shown in figure 4-11 convert the displayed format of the switch's (host) public key for easier visual comparison of the switch's public key to a copy of the key in a client's "known host" file. The switch always uses an ASCII version (without PEM encoding, or babble or fingerprint conversion) of its public key for file storage and default display format.

4. Enabling SSH on the Switch and Anticipating SSH Client Contact Behavior

The **ip ssh** command enables or disables SSH on the switch and modifies parameters the switch uses for transactions with clients. After you enable SSH, the switch can authenticate itself to SSH clients.

Note

Before enabling SSH on the switch you must generate the switch's public/private key pair. If you have not already done so, refer to "2. Generating the Switch's Public and Private Key Pair" on page 4-10.

When configured for SSH, the switch uses its host public-key to authenticate itself to SSH clients. If you also want SSH clients to authenticate themselves to the switch you must configure SSH on the switch for client public-key authentication at the login (Operator) level. To enhance security, you should also configure local, TACACS+, or RADIUS authentication at the enable (Manager) level.

Refer to "5. Configuring the Switch for SSH Authentication" on page 4-18.

SSH Client Contact Behavior. At the first contact between the switch and an SSH client, if you have not copied the switch's public key into the client, your client's first connection to the switch will question the connection and, for security reasons, give you the option of accepting or refusing. As long as you are confident that an unauthorized device is not using the switch's IP address in an attempt to gain access to your data or network, you can accept the connection. (As a more secure alternative, you can directly connect the client to the switch's serial port and copy the switch's public key into the client. See the following Note.)

Note

When an SSH client connects to the switch for the first time, it is possible for a "man-in-the-middle" attack; that is, for an unauthorized device to pose undetected as the switch, and learn the usernames and passwords controlling access to the switch. You can remove this possibility by directly connecting the management station to the switch's serial port, using a **show** command to display the switch's public key, and copying the key from the display into a file. This requires a knowledge of where your client stores public keys, plus the knowledge of what key editing and file format might be required by your client application. However, if your first contact attempt between a client and the switch does not pose a security problem, this is unnecessary.

To enable SSH on the switch.

1. Generate a public/private key pair if you have not already done so. (Refer to "2. Generating the Switch's Public and Private Key Pair" on page 4-10.)
2. Execute the **ip ssh** command.

To disable SSH on the switch, do either of the following:

- Execute **no ip ssh**.
- Zeroize the switch's existing key pair. (page 4-11).

Syntax: [no] ip ssh

Enables or disables SSH on the switch.

[key-size < 512 | 768 | 1024 >]

The size of the internal, automatically generated key the switch uses for negotiations with an SSH client. A larger key provides greater security; a smaller key results in faster authentication (default: 512 bits). See "Note on Port Number" on page 4-17.

[port < 1-65535 | default >]

*The IP port number for SSH connections (default: 22). **Important:** See "Note on Port Number" on page 4-17.*

[timeout < 5 - 120 >]

The SSH login timeout value (default: 120 seconds).

Note on Port Number

The **ip ssh key-size** command affects only a per-session, internal server key the switch creates, uses, and discards. This key is not accessible from the user interface. The switch's public (host) key is a separate, accessible key that is always 896 bits.

HP recommends using the default IP port number (22). However, you can use **ip ssh port** to specify any TCP port for SSH connections except those reserved for other purposes. Examples of reserved IP ports are 23 (Telnet) and 80 (http). Some other commonly reserved IP ports are 49, 80, 1506, and 1513.

```
HPswitch(config)# ip ssh
HPswitch(config)# show ip ssh

SSH Enabled           : Yes

IP Port Number       : 22
Timeout (sec)        : 120
Server Key Size (bits) : 512

Ses Type      Source IP and Port
-----
1  console
2  ssh        15.30.252.195:1722
3  telnet
4  inactive
```

Enables SSH on the switch.

Lists the current SSH configuration and status.

The switch uses these three settings internally for transactions with clients. See the **Note**, below.

With SSH running, the switch allows one console session and up to three other sessions (SSH and/or Telnet). Web browser sessions are also allowed, but does not appear in the **show ip ssh** listing.

Figure 4-12. Example of Enabling IP SSH and Listing the SSH Configuration and Status

Caution

Protect your private key file from access by anyone other than yourself. If someone can access your private key file, they can then penetrate SSH security on the switch by appearing to be you.

SSH does not protect the switch from unauthorized access via the web interface, Telnet, SNMP, or the serial port. While web and Telnet access can be restricted by the use of passwords local to the switch, if you are unsure of the security this provides, you may want to disable web-based and/or Telnet access (**no web-management** and **no telnet**). If you need to increase SNMP security, use the **snmp security** command. Another security measure is to use the Authorized IP Managers feature described in the switch's *Management and Configuration Guide*. To protect against unauthorized access to the serial port (and the Clear button, which removes local password protection), keep physical access to the switch restricted to authorized personnel.

5. Configuring the Switch for SSH Authentication

Note that all methods in this section result in authentication of the switch's public key by an SSH client. However, only Option B, below results in the switch also authenticating the client's public key. Also, for a more detailed discussion of the topics in this section, refer to "Further Information on SSH Client Public-Key Authentication" on page 4-21

Note

Hewlett-Packard recommends that you always assign a Manager-Level (enable) password to the switch. Without this level of protection, any user with Telnet, web, or serial port access to the switch can change the switch's configuration. Also, if you configure only an Operator password, entering the Operator password through Telnet, web, or serial port access enables full manager privileges. See "1. Assigning a Local Login (Operator) and Enable (Manager) Password" on page 4-9.

Option A: Configuring SSH Access for Password-Only SSH

Authentication. When configured with this option, the switch uses its public key to authenticate itself to a client, but uses only passwords for client authentication.

Syntax: `aaa authentication ssh login < local | tacacs | radius >[< local | none >]`

*Configures a password method for the primary and secondary login (Operator) access. If you do not specify an optional secondary method, it defaults to **none**.*

`aaa authentication ssh enable < local | tacacs | radius >[< local | none >]`

*Configures a password method for the primary and secondary enable (Manager) access. If you do not specify an optional secondary method, it defaults to **none**.*

Option B: Configuring the Switch for Client Public-Key SSH

Authentication. If configured with this option, the switch uses its public key to authenticate itself to a client, but the client must also provide a client public-key for the switch to authenticate. This option requires the additional step of copying a client public-key file from a TFTP server into the switch. This means that before you can use this option, you must:

1. Create a key pair on an SSH client.
2. Copy the client's public key into a public-key file (which can contain up to ten client public-keys).

3. Copy the public-key file into a TFTP server accessible to the switch and download the file to the switch.

(For more on these topics, refer to “Further Information on SSH Client Public-Key Authentication” on page 4-21.)

With steps 1 - 3, above, completed and SSH properly configured on the switch, if an SSH client contacts the switch, login authentication automatically occurs first, using the switch and client public-keys. After the client gains login access, the switch controls client access to the manager level by requiring the passwords configured earlier by the **aaa authentication ssh enable** command.

Syntax: copy tftp pub-key-file < ip-address > < filename > < local | none >

Copies a public key file into the switch.

aaa authentication ssh login rsa

*Configures the switch to authenticate a client public-key at the login level with an optional secondary password method (default: **none**).*

Caution

To allow SSH access *only* to clients having the correct public key, you *must* configure the secondary (password) method for **login rsa** to **none**. Otherwise a client without the correct public key can still gain entry by submitting a correct local login password.

Syntax: aaa authentication ssh enable < local | tacacs | radius > < local | none >

*Configures a password method for the primary and secondary enable (Manager) access. If you do not specify an optional secondary method, it defaults to **none**.*

For example, assume that you have a client public-key file named Client-Keys.pub (on a TFTP server at 10.33.18.117) ready for downloading to the switch. For SSH access to the switch you want to allow only clients having a private key that matches a public key found in Client-Keys.pub. For Manager-level (enable) access for successful SSH clients you want to use TACACS+ for primary password authentication and **local** for secondary password authentication, with a Manager username of "leader" and a password of "m0ns00n". To set up this operation you would configure the switch in a manner similar to the following:

Configuring Secure Shell (SSH)
Configuring the Switch for SSH Operation

```

HPswitch(config)# password manager user-name leader
New password for Manager: *****
Please retype new password for Manager: *****

HPswitch (config)# aaa authentication ssh login rsa none
HPswitch (config)# aaa authentication ssh enable tacacs local
HPswitch (config)# copy tftp pub-key-file 10.33.18.117 Client-Keys.pub
HPswitch (config)# write memory
  
```

Callouts in the diagram:

- Configures Manager user-name and password. (points to `password manager user-name leader`)
- Configures the switch to allow SSH access only a client whose public key matches one of the keys in the public key file (points to `aaa authentication ssh login rsa none`)
- Configures the primary and secondary password methods for Manager (enable) access. (Becomes available after SSH access is granted) (points to `aaa authentication ssh enable tacacs local`)
- Copies a public key file named "Client-Keys.pub" into the switch. (points to `copy tftp pub-key-file 10.33.18.117 Client-Keys.pub`)

Figure 4-13. Configuring for SSH Access Requiring a Client Public-Key Match and Manager Passwords

Figure 4-14 shows how to check the results of the above commands.

```

HPswitch(config)# show authentication
Status and Counters - Authentication Information
Login Attempts : 3

  | Login      Login      Enable      Enable
Access Task | Primary    Secondary  Primary     Secondary
-----+-----
Console    | Local      None        Local        None
Telnet     | Local      None        Local        None
Port-Access | Local
SSH        | RSA        None        Tacacs       Local

HPswitch(config)# show ip client-public-key
1024 35
1140740666170144690796380365284018053912704374511148288250928555011016860308261603895
9146896306569035982041222025542543282764329943344032963504381021098947647460524651531
6455722276820316076486036640205347034083710028842932315034922654093553211199274541340
543765609589968291386053556814705585051025488575846923smith@fellow

512 35
9210552662725956416192357815130947052205817856719413127292584858843442080864040396207
015631513328914504076264918047285352382655581475615051610646634228991kjlwilson@grayfie
lds
  
```

Callouts in the diagram:

- Lists the current SSH authentication configuration. (points to `show authentication`)
- Shows the contents of the public key file downloaded with the `copy tftp` command in figure 4-13. In this example, the file contains two client (points to the output of `show ip client-public-key`)

Figure 4-14. SSH Configuration and Client-Public-Key Listing From Figure 4-13

6. Use an SSH Client To Access the Switch

Test the SSH configuration on the switch to ensure that you have achieved the level of SSH operation you want for the switch. If you have problems, refer to "RADIUS-Related Problems" in the Troubleshooting chapter of the *Management and Configuration Guide* for your switch.

Further Information on SSH Client Public-Key Authentication

The section titled "5. Configuring the Switch for SSH Authentication" on page 4-18 lists the steps for configuring SSH authentication on the switch. However, if you are new to SSH or need more details on client public-key authentication, this section may be helpful.

When configured for SSH operation, the switch automatically attempts to use its own host public-key to authenticate itself to SSH clients. To provide the optional, opposite service—client public-key authentication to the switch—you can configure the switch to authenticate up to ten SSH clients. This requires storing an ASCII version of each client's public key (without PEM encoding, babble conversion, or fingerprint conversion) in a client public-key file that you create and TFTP-copy to the switch. In this case, only clients that have a private key corresponding to one of the stored public keys can gain access to the switch using SSH. *That is, if you use this feature, only the clients whose public keys are in the client public-key file you store on the switch will have SSH access to the switch over the network.* If you do not allow secondary SSH login (Operator) access via local password, then the switch will refuse other SSH clients.

SSH clients that support client public-key authentication normally provide a utility to generate a key pair. The private key is usually stored in a password-protected file on the local host; the public key is stored in another file and is not protected.

(Note that even without using client public-key authentication, you can still require authentication from whoever attempts to access the switch from an SSH client— by employing the local username/password, TACACS+, or RADIUS features. Refer to "5. Configuring the Switch for SSH Authentication" on page 4-18.)

If you enable client public-key authentication, the following events occur when a client tries to access the switch using SSH:

Configuring Secure Shell (SSH)

Further Information on SSH Client Public-Key Authentication

1. The client sends its public key to the switch with a request for authentication.
2. The switch compares the client's public key to those stored in the switch's client-public-key file. (As a prerequisite, you must use the switch's **copy tftp** command to download this file to flash.)
3. If there is not a match, and you have not configured the switch to accept a login password as a secondary authentication method, the switch denies SSH access to the client.
4. If there is a match, the switch:
 - a. Generates a random sequence of bytes.
 - b. Uses the client's public key to encrypt this sequence.
 - c. Send these encrypted bytes to the client.
5. The client uses its private key to decrypt the byte sequence.
6. The client then:
 - a. Combines the decrypted byte sequence with specific session data.
 - b. Uses MD5 to create a hash version of this information.
 - c. Returns the hash version to the switch.
7. The switch computes its own hash version of the data in step 6 and compares it to the client's hash version. If they match, then the client is authenticated. Otherwise, the client is denied access.

Using client public-key authentication requires these steps:

1. Generate a public/private key pair for each client you want to have SSH access to the switch. This can be a separate key for each client or the same key copied to several clients.
2. Copy the public key for each client into a client-public-key text file. (For the SSHv1 application used in the switch, this must be in the ASCII format (without PEM or any other encoding). If you are using an SSHv2 client application that creates its public key in a PEM-encoded ASCII string, you will need to convert the client's public key to a non-encoded version. Refer to the documentation provided with the application.)
3. Use **copy tftp** to copy the client-public-key file into the switch. Note that the switch can hold only one of these files. If there is already a client-public-key file in the switch and you copy another one into the switch, the second file replaces the first file.
4. Use the **aaa authentication ssh** command to enable client public-key authentication.

To Create a Client-Public-Key Text File. These steps describe how to copy client-public-keys into the switch for RSA challenge-response authentication, and require an understanding of how to use your SSH client application.

Bit Size	Public Index	Modulus	Comment
↓	↙	↘	↘
<pre>1024 35 11407406661701446907963803652840180539127043745111482882509285550110168603082 6038959146896306569035982041222025542543282764329943844032963504381021098947647460564 5572227682031607648603664020534703408371002884293231503492265409355321119922465153140 745413543765609589968291386053556814705585051025488575846923smith@support.cairns.com</pre>			

Figure 4-15. Example of a Client Public Key

Notes

Comments in public key files, such as **smith@support.cairns.com** in figure 4-15, may appear in a SSH client application’s generated public key. While such comments may help to distinguish one key from another, they do not pose any restriction on the use of a key by multiple clients and/or users.

Public key illustrations such as the key shown in figure 4-15 usually include line breaks as a method for showing the whole key. However, in practice, line breaks in a public key will cause errors resulting in authentication failure.

1. Use your SSH client application to create a public/private key pair. Refer to the documentation provided with your SSH client application for details. The switch supports the following client-public-key properties:

Property	Supported Value	Comments
Key Format	ASCII (no PEM or other encoding)	See figure 4-9 on page 4-13. The key must be one unbroken, non-encoded ASCII string. If you add more than one client-public-key to a file, terminate each key (except the last one) with a <CR><LF>. Spaces are allowed within the key to delimit the key’s components. Also, the switch supports only SSH version 1. If your SSH client supports SSHv2, then it may use the PEM format for creating its public key. In this case, you will need a method for converting the switch’s PEM-formatted public key into an ASCII-string equivalent. Note that, unlike the the use of the switch’s public key in an SSH client application, the format of a client-public-key used by the switch does not include the client’s IP address.
Key Type	RSA only	
Maximum Supported Public Key Length	3072 bits	Shorter key lengths allow faster operation, but also mean diminished security.
Maximum Key Size	1024 characters	Includes the bit size, public index, modulus, any comments, <CR>, <LF>, and all blank spaces. If necessary, you can use an editor application to verify the size of a key. For example, placing a client-public-key into a Word for Windows text file and clicking on File Properties Statistics , lets you view the number of characters in the file, including spaces.

Configuring Secure Shell (SSH)

Further Information on SSH Client Public-Key Authentication

2. Copy the client's public key (in ASCII, non-encoded format) into a text file (*filename.txt*). (For example, you can use the Notepad editor included with the Microsoft® Windows® software. If you want several clients to use client public-key authentication, copy a public key for each of these clients (up to ten) into the file. Each key should be separated from the preceding key by a <CR><LF>.
3. Copy the client-public-key file into a TFTP server accessible to the switch.

Copying a client-public-key into the switch requires the following:

- One or more client-generated public keys in non-encoded ASCII format. If you are using an SSHv2 client application, a client may encode its public key in PEM format. *To use the client public-key feature, you will need to convert the key to a non-encoded ASCII format.* Refer to the documentation provided with your SSH client application.
- A copy of each client public key (up to ten) stored in a single text file on a TFTP server to which the switch has access. (The text file should contain all client public keys for the clients you want to have access to the switch.) Terminate all client public-keys in the file except the last one with a <CR><LF>.

Note on Public Keys

The actual content of a public key entry in a public key file is determined by the SSH client application generating the key. (Although you can manually add or edit any comments the client application adds to the end of the key, such as the **smith@fellow** at the end of the key in figure 4-15 on page 4-23.)

The file on the TFTP server must contain non-encoded ASCII text of each public key you want copied. Also, the file must be a text file (such as *filename.txt*).

Syntax: copy tftp pub-key-file <ip-address> <filename>

Copies a public key file from a TFTP server into flash memory in the switch.

show ip client-public-key [babble | fingerprint]

Displays the client public key(s) in the switch's current client-public-key file.

*The **babble** option converts the key data to a phonetic hash that is easier for visual comparisons.*

*The **fingerprint** option converts the key data to a hexadecimal hash for the same purpose.*

For example, if you wanted to copy a client public-key file named **clientkeys.txt** from a TFTP server at 10.38.252.195 and then display the file contents:

```
HPswitch(config)# copy tftp pub-key-file 10.38.252.195 clientkeys.txt
HPswitch(config)# show ip client-public-key
1024 35
1140740666170144690796380365284018053912704374511148288250928555011016860308261603895
9146896306569035982041222025542543282764329943344032963504381021098947647460524651531
6455722276820316076486036640205347034083710028842932315034922654093553211199274541340
543765609589968291386053556814705585051025488575846923smith@fellow

512 35
9210552662725956416192357815130947052205817856719413127292584858843442080864040396207
015631513328914504076264918047285352382655581475615051610646634228991kjwilson@grayfile
lds
```

Figure 4-16. Example of Copying and Displaying a Client Public-Key File Containing Two Client Public Keys

Replacing or Clearing the Public Key File. The client public-key file remains in the switch's flash memory even if you erase the startup-config file, reset the switch, or reboot the switch.

- You can replace the existing client public-key file by copying a new client public-key file into the switch
- You can remove the existing client public-key file by executing the **clear public-key** command.

Syntax: clear public-key

Deletes the client-public-key from the switch.

For example:

```
HPswitch(config)# clear public-key
HPswitch(config)# show ip client-public-key
show_client_public_key: cannot stat keyfile
```

Clearing the public key file removes file from flash memory, and does not require a write memory command to make the change permanent.

Enabling Client Public-Key Authentication. After you TFTP a client-public-key file into the switch (described above), you can configure the switch to allow one of the following:

- If an SSH client's public key matches the switch's client-public-key file, allow that client access to the switch. If there is not a public-key match, then deny access to that client.
- If an SSH client's public key does not have a match in the switch's client-public-key file, allow the client access if the user can enter the switch's login (Operator) password. (If the switch does not have an Operator password, then deny access to that client.)

Syntax: aaa authentication ssh login rsa none

Allows SSH client access only if the switch detects a match between the client's public key and an entry in the client-public-key file most recently copied into the switch.

aaa authentication ssh login rsa local

Allows SSH client access if there is a public key match (see above) or if the client's user enters the switch's login (Operator) password.

With **login rsa local** configured, if the switch does not have an Operator-level password, it blocks client public-key access to SSH clients whose private keys do not match a public key in the switch's client-public-key file.

Caution

To enable client public-key authentication to block SSH clients whose public keys are not in the client-public-key file copied into the switch, you must configure the Login Secondary as **none**. Otherwise, the switch allows such clients to attempt access using the switch's Operator password.

Messages Related to SSH Operation

Message	Meaning
00000K Peer unreachable.	Indicates an error in communicating with the tftp server or not finding the file to download. Causes include such factors as: <ul style="list-style-type: none">• Incorrect IP configuration on the switch• Incorrect IP address in the command• Case (upper/lower) error in the filename used in the command• Incorrect configuration on the TFTP server• The file is not in the expected location.• Network misconfiguration• No cable connection to the network

Message	Meaning
00000K Transport error.	Indicates the switch experienced a problem when trying to copy tftp the requested file. The file may not be in the expected directory, the filename may be misspelled in the command, or the file permissions may be wrong.
Cannot bind reserved TCP port <port-number>.	The ip ssh port command has attempted to configure a reserved TCP port. Use the default or select another port number. See "Note on Port Number" on page 4-17.
Client public key file corrupt or not found. Use 'copy tftp pub-key-file <ip-addr> <filename>' to download new file.	The client key does not exist in the switch. Use copy tftp to download the key from a TFTP server.
Download failed: overlength key in key file.	<p>The public key file you are trying to download has one of the following problems:</p> <ul style="list-style-type: none"> • A key in the file is too long. The maximum key length is 1024 characters, including spaces. This could also mean that two or more keys are merged together instead of being separated by a <CR><LF>. • There are more than ten public keys in the key file. • One or more keys in the file is corrupted or is not a valid rsa public key. <p>Refer to "To Create a Client-Public-Key Text File" on page 23 for information on client-public-key properties.</p>
Download failed: too many keys in key file.	
Download failed: one or more keys is not a valid RSA public key.	
Error: Requested keyfile does not exist.	The client key does not exist in the switch. Use copy tftp to download the key from a TFTP server.
Generating new RSA host key. If the cache is depleted, this could take up to two minutes.	After you execute the crypto key generate [rsa] command, the switch displays this message while it is generating the key.
Host RSA key file corrupt or not found. Use 'crypto key generate rsa' to create new host key.	The switch's key is missing or corrupt. Use the crypto key generate [rsa] command to generate a new key for the switch.
host_ssh1 is not a valid key file.	The client key does not exist in the switch. Use copy tftp to download the key from a TFTP server.
Key does not exist or is corrupt.	
show_client_public-key: cannot stat keyfile.	

Configuring Secure Shell (SSH)
Messages Related to SSH Operation

Configuring Port-Based Access Control (802.1x)

Contents

Overview	5-2
How 802.1x Operates	5-4
Authenticator Operation	5-4
Switch-Port Supplicant Operation	5-5
Terminology	5-6
General Operating Rules and Notes	5-7
General Setup Procedure for Port-Based Access	
Control (802.1x)	5-8
Before You Begin	5-8
Overview: Configuring 802.1x Authentication on the Switch	5-9
Configuring Switch Ports as 802.1x Authenticators	5-10
1. Disable LACP on the Ports Selected for 802.1x Access	5-10
2. Enable 802.1x Authentication on Selected Ports	5-11
3. Configure the 802.1x Authentication Method	5-13
4. Enter the RADIUS Host IP Address(es)	5-14
5. Optional: For Authenticator Ports, Configure Port-Security To	
Allow Only 802.1x Devices	5-15
6. Enable 802.1x Authentication on the Switch	5-16
Configuring Switch Ports To Operate As Supplicants for 802.1x	
Connections to Other Switches	5-17
Displaying 802.1x Configuration, Statistics, and Counters	5-21
Show Commands for Port-Access Authenticator	5-21
Show Commands for Port-Access Supplicant	5-23
How 802.1x Authentication Affects VLAN Operation	5-24
Messages Related to 802.1x Operation	5-28

Overview

Feature	Default	Menu	CLI	Web
Configuring Switch Ports as 802.1x Authenticators	Disabled	n/a	page 5-10	n/a
Configuring Switch Ports to Operate as 802.1x Supplicants	Disabled	n/a	page 5-17	n/a
Displaying 802.1x Configuration, Statistics, and Counters	n/a	n/a	page 5-21	n/a
How 802.1x Affects VLAN Operation	n/a	n/a	page 5-24	n/a
RADIUS Authentication and Accounting	Refer to "RADIUS Authentication and Accounting" on page 3-1			

Why Use Port-Based Access Control?

Local Area Networks are often deployed in a way that allows unauthorized clients to attach to network devices, or allows unauthorized users to get access to unattended clients on a network. Also, the use of DHCP services and zero configuration make access to networking services easily available. This exposes the network to unauthorized use and malicious attacks. While access to the network should be made easy, uncontrolled and unauthorized access is usually not desirable. 802.1x provides access control along with the ability to control user profiles from a central RADIUS server while allowing users access from multiple points within the network.

General Features

802.1x on the Series 4100GL switches includes the following:

- Switch operation as both an authenticator (for supplicants having a point-to-point connection to the switch) and as a supplicant for point-to-point connections to other 802.1x-aware switches.
 - Authentication of 802.1x clients using a RADIUS server and either the EAP or CHAP protocol.
 - Supplicant implementation using CHAP authentication and independent username and password configuration on each port.
- Prevention of traffic flow in either direction on unauthorized ports.
- Local authentication of 802.1x clients using the switch's local username and password (as an alternative to RADIUS authentication).

- Temporary on-demand change of a port's VLAN membership status to support a current client's session. (This does not include ports that are members of a trunk.)
- Session accounting with a RADIUS server, including the accounting update interval.
- Use Show commands to display session counters.
- With port-security enabled for port-access control, limit a port to one 802.1x client session at a given time.

Authenticating Users. Port-Based Access Control (802.1x) provides switch-level security that allows LAN access only to users who enter the authorized RADIUS username and password on 802.1x-capable clients (supplicants). This simplifies security management by allowing you to control access from a master database in a single server (although you can use up to three RADIUS servers to provide backups in case access to the primary server fails). It also means a user can enter the same username and password pair for authentication, regardless of which switch is the access point into the LAN. Note that you can also configure 802.1x for authentication through the switch's local username and password instead of a RADIUS server, but doing so increases the administrative burden, decentralizes username/password administration, and reduces security by limiting the available authentication methods to only one: MD5.

Authenticating One Switch to Another. 802.1x authentication also enables the switch to operate as a supplicant when connected to a port on another switch running 802.1x authentication.

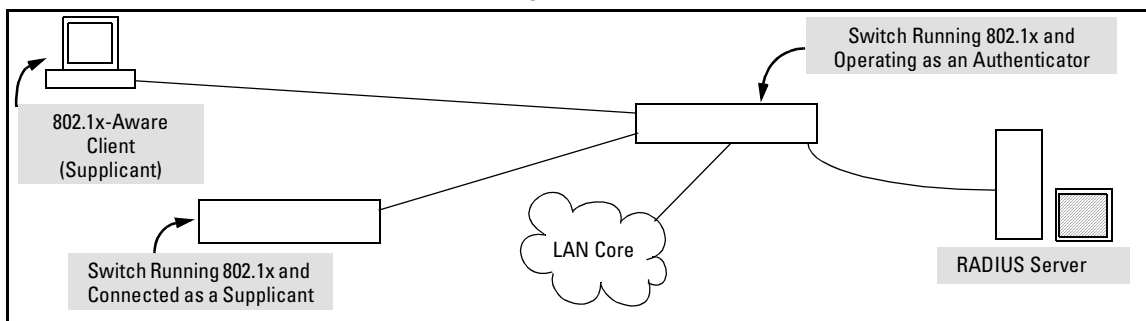

Figure 5-1. Example of an 802.1x Application

Accounting . The Series 4100GL switches also provide RADIUS Network accounting for 802.1x access. Refer to “Configuring RADIUS Accounting” on page 3-16.

How 802.1x Operates

Authenticator Operation

This operation provides security on a direct link between a single client and the switch, where both devices are 802.1x-aware. For example, suppose that you have configured a port on the switch for 802.1x authentication operation. If you then connect an 802.1x-aware client (supplicant) to the port and attempt to log on:

1. When the switch detects the client on the port, it blocks access to the LAN from that port.
2. The switch responds with an identity request.
3. The client responds with a user name that uniquely defines this request for the client.
4. The switch responds in one of the following ways:
 - If 802.1x (port-access) on the switch is configured for RADIUS authentication, the switch then forwards the request to a RADIUS server.
 - i. The server responds with an access challenge which the switch forwards to the client.
 - ii. The client then provides identifying credentials (such as a user certificate), which the switch forwards to the RADIUS server.
 - iii. The RADIUS server then checks the credentials provided by the client.
 - iv. If the client is successfully authenticated and authorized to connect to the network, then the server notifies the switch to allow access to the client. Otherwise, access is denied and the port remains blocked.
 - If 802.1x (port-access) on the switch is configured for local authentication, then:
 - i. The switch compares the client's credentials with the username and password configured in the switch (Operator or Manager level).
 - ii. If the client is successfully authenticated and authorized to connect to the network, then the switch allows access to the client. Otherwise, access is denied and the port remains blocked.

Switch-Port Supplicant Operation

This operation provides security on links between 802.1x-aware switches. For example, suppose that you want to connect two switches, where:

- Switch "A" has port A1 configured for 802.1x supplicant operation
- You want to connect port A1 on switch "A" to port B5 on switch "B".

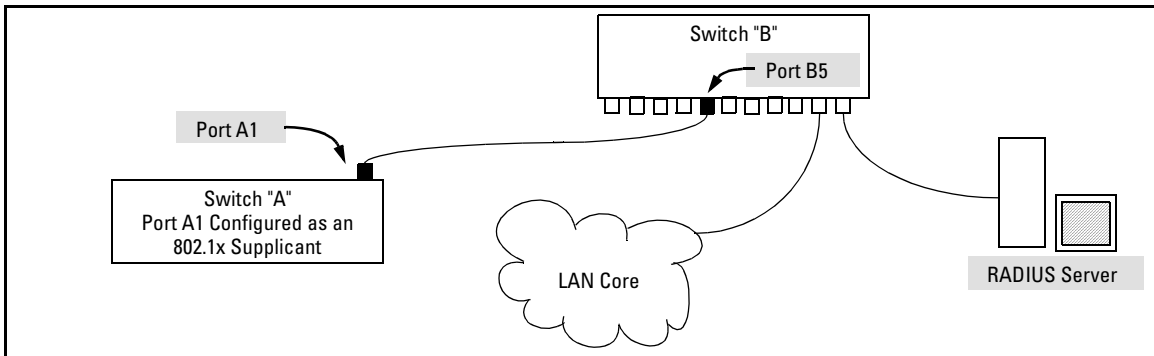

Figure 5-2. Example of Supplicant Operation

1. When port A1 on switch "A" is first connected to a port on switch "B", or if the ports are already connected and either switch reboots, port A1 begins sending start packets to port B5 on switch "B".
 - If, after the supplicant port sends the configured number of start packets, it does not receive a response, it assumes that switch "B" is not 802.1x-aware, and transitions to the authenticated state. If switch "B" is operating properly and is not 802.1x-aware, then the link should begin functioning normally, but without 802.1x security.
 - If, after sending one or more start packets, port A1 receives a request packet from port B5, then switch "B" is operating as an 802.1x authenticator. The supplicant port then sends a response/ID packet. Switch "B" forwards this request to a RADIUS server.
2. The RADIUS server then responds with an MD5 access challenge that switch "B" forwards to port A1 on switch "A".
3. Port A1 replies with an MD5 hash response based on its username and password or other unique credentials. Switch "B" forwards this response to the RADIUS server.
4. The RADIUS server then analyzes the response and sends either a "success" or "failure" packet back through switch "B" to port A1.
 - A "success" response unblocks port B5 to normal traffic from port A1.

- A "failure" response continues the block on port B5 and causes port A1 to wait for the "held-time" period before trying again to achieve authentication through port B5.

Note

You can configure a switch port to operate as both a supplicant and an authenticator at the same time.

Terminology

Authentication Server: The entity providing an authentication service to the switch when the switch is configured to operate as an authenticator. In the case of a Series 4100GL switch running 802.1x, this is a RADIUS server (unless local authentication is used, in which case the switch performs this function using its own username and password for authenticating a supplicant).

Authenticator: In HP Procurve switch applications, a device such as a Series 4100GL switch that requires a supplicant to provide the proper credentials (username and password) before being allowed access to the network.

CHAP (MD5): Challenge Handshake Authentication Protocol.

Client: In this application, a end-node device such as a management station, workstation, or mobile PC linked to the switch through a point-to-point LAN link.

EAP (Extensible Authentication Protocol): EAP enables network access that supports multiple authentication methods.

EAPOL : Extensible Authentication Protocol Over LAN, as defined in the 802.1x standard.

MD5: An algorithm for calculating a unique digital signature over a stream of bytes. It is used by CHAP to perform authentication without revealing the shared secret (password).

Supplicant: The entity that must provide the proper credentials to the switch before receiving access to the network. This is usually an end-user workstation, but it can be a switch, router, or another device seeking network services.

General Operating Rules and Notes

- When a port on the switch is configured as either an authenticator or supplicant and is connected to another device, rebooting the switch causes a re-authentication of the link.
- When a port on the switch is configured as an authenticator, it will block access to a client that either does not provide the proper authentication credentials or is not 802.1x-aware.
- If a port on switch "A" is configured as an 802.1x supplicant and is connected to a port on another switch, "B", that is not 802.1x-aware, access to switch "B" will occur without 802.1x security protection.
- If a port on switch "A" is configured as both an 802.1x authenticator *and* supplicant and is connected to a port on another switch, "B", that is not 802.1x-aware, access to switch "B" will occur without 802.1x security protection, but switch "B" will not be allowed access to switch "A". This means that traffic on this link between the two switches will flow from "A" to "B", but not the reverse.
- If a client already has access to a switch port when you configure the port for 802.1x authenticator operation, the port will block the client from further network access until it can be authenticated.
- You can configure a port as both an 802.1x authenticator *and* an 802.1x supplicant.
- On a port configured for 802.1x with RADIUS authentication, if the RADIUS server specifies a VLAN for the supplicant and the port is a trunk member, the port will be blocked. If the port is later removed from the trunk, the port will try to authenticate the supplicant. If authentication is successful, the port becomes unblocked. Similarly, if the supplicant is authenticated and later the port becomes a trunk member, the port will be blocked. If the port is then removed from the trunk, it tries to re-authenticate the supplicant. If successful, the port becomes unblocked.
- To help maintain security, 802.1x and LACP cannot both be enabled on the same port. If you try to configure 802.1x on a port already configured for LACP (or the reverse) you will see a message similar to the following:

Error configuring port X: LACP and 802.1x cannot be run together.

**Note on 802.1x
and LACP**

To help maintain security, the switch does not allow 802.1x and LACP to both be enabled at the same time on the same port. Refer to “802.1x Operating Messages” on page 5-28

General Setup Procedure for Port-Based Access Control (802.1x)

Before You Begin

1. Configure a local username and password on the switch for both the Operator (login) and Manager (enable) access levels. (While this may or may not be required for your 802.1x configuration, HP recommends that you use a local username and password pair at least until your other security measures are in place.)
2. Determine which ports on the switch you want to operate as authenticators and/or supplicants, and disable LACP on these ports. (See the “Note on 802.1x and LACP” on page 5-8.)
3. For each port you want to operate as a supplicant, determine a username and password pair. You can either use the same pair for each port or use unique pairs for individual ports or subgroups of ports. (This can also be the same local username/password pair that you assign to the switch.)
4. Unless you are using only the switch’s local username and password for 802.1x authentication, configure at least one RADIUS server to authenticate access requests coming through the ports on the switch from external supplicants (including switch ports operating as 802.1x supplicants). You can use up to three RADIUS servers for authentication; one primary and two backups. Refer to the documentation provided with your RADIUS application.

Overview: Configuring 802.1x Authentication on the Switch

This section outlines of the steps for configuring 802.1x on the switch. For detailed information on each step, refer to “Configuring the Switch for RADIUS Authentication” on page 3-6 or “Configuring Switch Ports To Operate As Supplicants for 802.1x Connections to Other Switches” on page 5-17.

1. Disable LACP on the ports on which you want to use 802.1x authentication. (Refer to the “Note on 802.1x and LACP” on page 5-8.)
2. Enable 802.1x authentication on the individual ports you want to serve as authenticators. On the ports you will use as authenticators, either accept the default 802.1x settings or change them, as necessary. Note that, by default, the port-control parameter is set to **auto** for all ports on the switch. This requires a client to support 802.1x authentication and to provide valid credentials to get network access.

See page 5-11.

3. Configure the 802.1x authentication type. Options include:
 - Local Operator username and password (the default). This allows a client to use the switch’s local username and password as valid 802.1x credentials for network access.
 - EAP RADIUS: Use if your RADIUS server application supports EAP authentication for 802.1x.
 - CHAP (MD5) RADIUS: Use if your RADIUS server application supports CHAP (MD5) authentication.

See page 5-13.

4. If you selected either **eap-radius** or **chap-radius** for step 3, use the **radius host** command to configure up to three RADIUS server IP address(es) on the switch. See page 5-14.
5. Enable 802.1x authentication on the switch. See page 5-16.
6. Test both the authorized and unauthorized access to your system to ensure that the 802.1x authentication works properly on the ports you have configured for port-access.

Note

If you want to implement the optional port security feature (step 7) on the switch, you should first ensure that the ports you have configured as 802.1x authenticators operate as expected.

7. If you are using Port Security on the switch, configure the switch to allow only 802.1x access on ports configured for 802.1x operation, and (if desired) the action to take if an unauthorized device attempts access through an 802.1x port. See page 5-15.
8. Configure 802.1x supplicant management on designated ports. See page 5-17.

Configuring Switch Ports as 802.1x Authenticators

802.1x Authentication Commands	Table
[no] aaa port-access authenticator < [ethernet] < port-list >	5-11
[control quiet-period tx-period supplicant-timeout server-timeout max-requests reauth-period initialize reauthenticate clear-statistics]	5-11
aaa authentication port-access < local eap-radius chap-radius >	5-13
[no] aaa port-access authenticator active	5-16
[no] port-security [ethernet] < port-list > learn-mode port-access	5-15
802.1x Supplicant Commands	5-17
802.1x-Related Show Commands	5-21
RADIUS server configuration	5-14

1. Disable LACP on the Ports Selected for 802.1x Access

Syntax: no interface [e] < port-list > lacp

Disables LACP on the designated ports.

Use **show lacp** to verify that LACP is disabled on the desired ports.

2. Enable 802.1x Authentication on Selected Ports

This task configures the individual ports you want to operate as 802.1x authenticators for point-to-point links to 802.1x-aware clients or switches. (Actual 802.1x operation does not commence until you perform step 5 on page 5-16 to activate 802.1x authentication on the switch.)

Syntax: `aaa port-access authenticator < port-list >`

Enables specified ports to operate as 802.1x authenticators with current per-port authenticator configuration. To activate configured 802.1x operation, you must enable 802.1x authentication. Refer to "5. Enable 802.1x Authentication on the switch" on page 5-16.

`[control < authorized | auto | unauthorized >]`

Controls authentication mode on the specified port:

auto (the default): *The device connected to the port must support 802.1x authentication and provide valid credentials in order to get network access.*

authorized: *Also termed Force Authorized. Grants access to any device connected to the port. In this case, the device does not have to provide 802.1x credentials or support 802.1x authentication. (However, you can still configure console, Telnet, or SSH security on the port.)*

unauthorized: *Also termed Force Unauthorized. Do not grant access to the network, regardless of whether the device provides the correct credentials and has 802.1x support. In this state, the port blocks access to any connected device.*

aaa port-access authenticator < port-list > **(Syntax Continued)**

[quiet-period < 0 .. 65535 >]

*Sets the period during which the port does not try to acquire a supplicant. The period begins after the last attempt authorized by the **max-requests** parameter fails (next page). (Default: 60 seconds)*

[tx-period < 0 .. 65535 >]

Sets the period the port waits to retransmit the next EAPOL PDU during an authentication session. (Default: 30 seconds)

[supplicant-timeout < 1 - 300 >]

Sets the period of time the switch waits for a supplicant response to an EAP request. If the supplicant does not respond within the configured time frame, the session times out. (Default: 30 seconds)

[server-timeout < 1 - 300 >]

*Sets the period of time the switch waits for a server response to an authentication request. If the server does not respond within the configured time frame, the switch assumes that the authentication attempt has timed out. Depending on the current **max-requests** setting, the switch will either send a new request to the server or end the authentication session. (Default: 30 seconds)*

[max-requests < 1 - 10 >]

*Sets the number of authentication attempts that must time-out before authentication fails and the authentication session ends. If you are using the Local authentication option, or are using RADIUS authentication with only one host server, the switch will not start another session until a client tries a new access attempt. If you are using RADIUS authentication with two or three host servers, the switch will open a session with each server, in turn, until authentication occurs or there are no more servers to try. During the **quiet-period** (previous page), if any, you cannot reconfigure this parameter. (Default: 2)*

aaa port-access authenticator < port-list > **(Syntax Continued)**

[reauth-period < 1 - 9999999 >]

Sets the period of time after which clients connected must be re-authenticated. When the timeout is set to 0 the reauthentication is disabled (Default: 0 second)

[initialize]

*On the specified ports, blocks inbound and outbound traffic and restarts the 802.1x authentication process. This behavior occurs only on ports configured with **control auto** and actively operating as 802.1x authenticators. **Note:** If a specified port is configured with **control authorized** and **port-security**, and the port has learned an authorized address, the port will remove this address and learn a new one from the first packet it receives.*

[reauthenticate]

Forces reauthentication (unless the authenticator is in 'HELD' state).

[clear-statistics]

Clears authenticator statistics counters.

3. Configure the 802.1x Authentication Method

This task specifies how the switch will authenticate the credentials provided by a supplicant connected to a switch port configured as an 802.1x authenticator.

Syntax: aaa authentication port-access < local | eap-radius | chap-radius >

Determines the type of RADIUS authentication to use.

local

Use the switch's local username and password for supplicant authentication.

eap-radius

Use EAP-RADIUS authentication. (Refer to the documentation for your RADIUS server.)

chap-radius

Use CHAP-RADIUS authentication. (Refer to the documentation for your RADIUS server application.)

For example, to enable the switch to perform 802.1x authentication using one or more EAP-capable RADIUS servers:

```

HPswitch(config)# aaa authentication port-access eap-radius
HPswitch(config)# show auth
    
```

Status and Counters - Authentication Information
 Login Attempts : 3

Access Task	Login Primary	Login Secondary	Enable Primary	Enable Secondary
Console	Local	None	Local	None
Telnet	Local	None	Local	None
Port-Access	EapRadius			
SSH	Local	None	Local	None

Annotations:
 - Arrow from 'aaa authentication port-access eap-radius' points to 'Configuration command for EAP-RADIUS authentication.'
 - Arrow from 'EapRadius' in the table points to '802.1x (Port-Access) configured for EAP-RADIUS authentication.'

Figure 5-3. Example of 802.1x (Port-Access) Authentication

4. Enter the RADIUS Host IP Address(es)

If you selected either **eap-radius** or **chap-radius** for the authentication method, configure the switch to use 1 to 3 RADIUS servers for authentication. The following syntax shows the basic commands. For coverage of all commands related to RADIUS server configuration, refer to “RADIUS Authentication and Accounting” on page 3-1.

Syntax: radius host < ip-address >

Adds a server to the RADIUS configuration.

[key < server-specific key-string >]

Optional. Specifies an encryption key for use during authentication (or accounting) sessions with the specified server. This key must match the key used on the RADIUS server. Use this option only if the specified server requires a different key than configured for the global encryption key.

radius-server key < global key-string >

Specifies the global encryption key the switch uses for sessions with servers for which the switch does not have a server-specific key. This key is optional if all RADIUS server addresses configured in the switch include a server-specific encryption key.

5. Optional: For Authenticator Ports, Configure Port-Security To Allow Only 802.1x Devices

If you are using port-security on authenticator ports, you can configure it to learn only the MAC address of the first 802.1x-aware device detected on the port. Then, only traffic from this specific device is allowed on the port. When this device logs off, another 802.1x-aware device can be authenticated on the port.

Syntax: port-security [ethernet] < port-list >

learn-mode port-access

Configures port-security on the specified port(s) to allow only the first 802.1x-aware device that the port detects.

action < none | send-alarm | send-disable >

Configures the port's response (in addition to blocking unauthorized traffic) to detecting an intruder.

Note

Port-Security operates with 802.1x authentication as described above only if the affected ports are configured as 802.1x; that is with the **control** mode in the port-access authenticator command set to **auto**. For example, to configure port A10 for 802.1x authenticator operation and display the result:

```
HPswitch(config)# aaa port-access authenticator e A10
control auto
HPswitch(config)# show port-access authenticator e A10
config
```

**Note on
Blocking a Non-
802.1x Device**

If the port's 802.1x authenticator **control** mode is configured to **authorized** (as shown below, instead of **auto**), then the first source MAC address from any device, whether 802.1x-aware or not, becomes the only authorized device on the port.

```
aaa port-access authenticator < port-list > control authorized
```

With 802.1x authentication disabled on a port or set to **authorized** (Force Authorize), the port may learn a MAC address that you don't want authorized. If this occurs, you can block access by the unauthorized, non-802.1x device by using one of the following options:

- If 802.1x authentication is disabled on the port, use these command syntaxes to enable it and allow only an 802.1x-aware device:

```
aaa port-access authenticator e < port-list >
```

Enables 802.1x authentication on the port.

```
aaa port-access authenticator e < port-list > control auto
```

Forces the port to accept only a device that supports 802.1x and supplies valid credentials.

If 802.1x authentication is enabled on the port, but set to **authorized** (Force Authorized), use this command syntax to allow only an 802.1x-aware device:

```
aaa port-access authenticator e < port-list > control auto
```

Forces the port to accept only a device that supports 802.1x and supplies valid credentials.

6. Enable 802.1x Authentication on the Switch

After configuring 802.1x authentication as described in the preceding four sections, activate it with the the following command:

Syntax: `aaa port-access authenticator active`

Activates 802.1x port-access on ports you have configured as authenticators.

Configuring Switch Ports To Operate As Supplicants for 802.1x Connections to Other Switches

802.1x Authentication Commands	page 5-10
802.1x Supplicant Commands	
[no] aaa port-access < supplicant < [ethernet] < <i>port-list</i> >	page 5-18
[auth-timeout held-period start-period max-start initialize identity secret clear-statistics]	page 5-19
802.1x-Related Show Commands	page 5-21
RADIUS server configuration	pages 5-14

You can configure a switch port to operate as a supplicant in a connection to a port on another 802.1x-aware switch to provide security on links between 802.1x-aware switches. (Note that a port can operate as both an authenticator and a supplicant.)

For example, suppose that you want to connect two switches, where:

- Switch "A" has port A1 configured for 802.1x supplicant operation
- You want to connect port A1 on switch "A" to port B5 on switch "B".

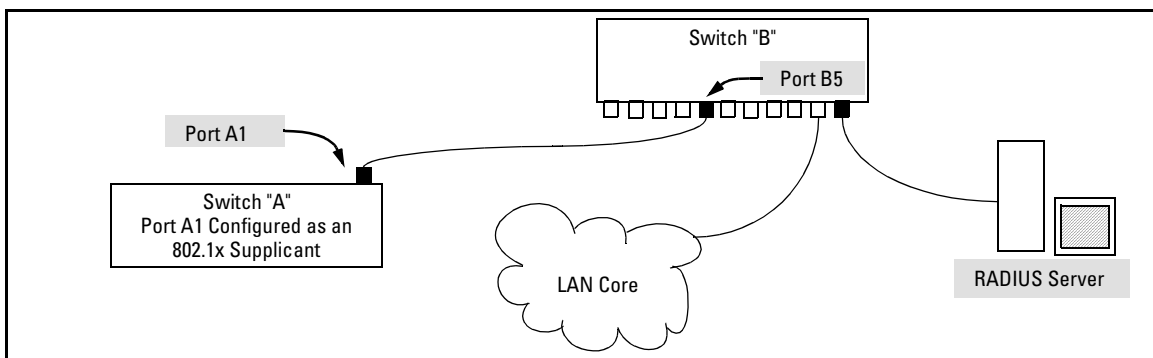

Figure 5-4. Example of Supplicant Operation

1. When port A1 on switch "A" is first connected to a port on switch "B", or if the ports are already connected and either switch reboots, port A1 begins sending start packets to port B5 on switch "B".
 - If, after the supplicant port sends the configured number of start request packets, it does not receive a response, it assumes that switch "B" is not 802.1x-aware, and transitions to the authenticated state. If switch "B" is operating properly and is not 802.1x-aware, then the link should begin functioning normally, but without 802.1x security.
 - If, after sending one or more start request packets, port A1 receives a request packet from port B5, then switch "B" is operating as an 802.1x authenticator. The supplicant port then sends a response/ID packet. If switch "B" is configured for RADIUS authentication, it forwards this request to a RADIUS server. If switch "B" is configured for Local 802.1x authentication (page 5-13), the authenticator compares the switch "A" response to its local username and password.
2. The RADIUS server then responds with an access challenge that switch "B" forwards to port A1 on switch "A".
3. Port A1 replies with a hash response based on its unique credentials . Switch "B" forwards this response to the RADIUS server.
4. The RADIUS server then analyzes the response and sends either a "success" or "failure" packet back through switch "B" to port A1.
 - A "success" response unblocks port B5 to normal traffic from port A1.
 - A "failure" response continues the block on port B5 and causes port A1 to wait for the "held-time" period before trying again to achieve authentication through port B5.

Note

You can configure a switch port to operate as both a supplicant and an authenticator at the same time.

Enabling a Switch Port To Operate as a Supplicant. You can configure one or more switch ports to operate as supplicants for point-to-point links to 802.1x-aware ports on other switches. *You must configure a port as a supplicant before you can configure any supplicant-related parameters.*

Syntax: [no] aaa port-access supplicant [ethernet] < port-list >

Configures a port to operate as a supplicant using either the default supplicant parameters or any previously configured supplicant parameters, whichever is the most recent. The "no" form of the command disables supplicant operation on the specified ports.

Configuring a Supplicant Switch Port. Note that you must enable supplicant operation on a port before you can change the supplicant configuration. This means you must execute the supplicant command once without any other parameters, then execute it again with a supplicant parameter you want to configure. If the intended authenticator port uses RADIUS authentication, then use the **identity** and **secret** options to configure the RADIUS-expected username and password on the supplicant port. If the intended authenticator port uses Local 802.1x authentication, then use the **identity** and **secret** options to configure the authenticator switch's local username and password on the supplicant port.

Syntax: aaa port-access supplicant [ethernet] < port-list >

*To enable supplicant operation on the designated ports, execute this command without any other parameters. After doing this, you can use the command again with the following parameters to configure supplicant operation. (Use one instance of the command for each parameter you want to configure. The **no** form disables supplicant operation on the designated port(s).*

[identity < username >]

[secret]

Enter secret: < password >

Repeat secret: < password >

*Sets the username and password to pass to the authenticator port when a challenge-request packet is received from the authenticator port in response to an authentication request. If the intended authenticator port is configured for RADIUS authentication, then < username > and < password > must be the username and password expected by the RADIUS server. If the intended authenticator port is configured for Local authentication, then < username > and < password > must be the username and password configured on the Authenticator switch.
(Defaults: Null)*

aaa port-access supplicant [ethernet] < port-list > **(Syntax Continued)**

[auth-timeout < 1 - 300 >]

*Sets the period of time the port waits to receive a challenge from the authenticator. If the request times out, the port sends another authentication request, up to the number of attempts specified by the **max-start** parameter. (Default: 30 seconds).*

[max-start < 1 .. 10 >]

Defines the maximum number of times the supplicant port requests authentication. See step 1 on page 5-18 for a description of how the port reacts to the authenticator response. (Default: 3).

[held-period < 0 .. 65535 >]

Sets the time period the supplicant port waits after an active 802.1x session fails before trying to re-acquire the authenticator port. (Default: 60 seconds)

[start-period < 1 .. 300 >]

*Sets the time period between Start packet retransmissions. That is, after a supplicant sends a start packet, it waits during the **start-period** for a response. If no response comes during the **start-period**, the supplicant sends a new start packet. The **max-start** setting (above) specifies how many start attempts are allowed in the session. (Default: 30 seconds)*

aaa port-access supplicant [ethernet] < port-list >

[initialize]

On the specified ports, blocks inbound and outbound traffic and restarts the 802.1x authentication process. Affects only ports configured as 802.1x supplicants.

[clear-statistics]

Clears and restarts the 802.1x supplicant statistics counters.

Displaying 802.1x Configuration, Statistics, and Counters

802.1x Authentication Commands	page 5-10
802.1x Supplicant Commands	page 5-17
802.1x-Related Show Commands	
show port-access authenticator	below
show port-access supplicant	page 5-23
RADIUS server configuration	pages 5-14

Show Commands for Port-Access Authenticator

Syntax: show port-access authenticator

*Shows whether port-access authenticator is active (**Yes** or **No**) and the status of all ports configured for 802.1x authentication. The **Authenticator Backend State** in this data refers to the switch's interaction with the authentication server.*

[e] < port-list >

Same as above, but limits port status to only the specified port. The statistics values are blank if the specified port is not enabled as an authenticator.

config

Shows whether port-access authenticator is active and the 802.1x configuration of the specified port. The configuration settings are blank if the specified port is not enabled as an authenticator.

show port-access authenticator (**Syntax Continued**)

[e] < port-list >

statistics

Shows whether port-access authenticator is active and the statistics of the specified port. Includes the supplicant's MAC address, as determined by the content of the last EAPOL frame received on the port. The statistics values are blank if the specified port is not enabled as an authenticator.

session-counters

*Shows whether port-access authenticator is active the session data, session status on the specified port. Also, for each port, the "User" column lists the user name the supplicant included in its response packet. (For the switch, this is the **identity** setting included in the **supplicant** command—page 5-19.) The fields are blank if the specified port is not enabled as an authenticator.*

[statistics]

*Same as the **statistics** command (above), but for all ports on the switch that are enabled as authenticators.*

[e] < port-list >

*Same as the [e] < port-list > **statistics** command (above).*

[session-counters]

*Same as the [e] < port-list > **session-counters** command (above), but for all ports on the switch that are enabled as authenticators.*

[e] < port-list >

*Same as the [e] < port-list > **session-counters** command (above).*

Show Commands for Port-Access Supplicant

Syntax: show port-access supplicant

Shows the port-access supplicant configuration (excluding the **secret** parameter) for the ports configured on the switch as supplicants. The Supplicant State can include the following:

Connecting - Starting authentication.

Authenticated - Authentication completed (regardless of whether the attempt was successful).

Acquired - The port received a request for identification from an authenticator.

Authenticating - Authentication is in progress.

Held - Authenticator sent notice of failure. The supplicant port is waiting for the authenticator's held-period (page 5-19).

For descriptions of the supplicant parameters, refer to "Configuring a Supplicant Switch Port" on page 19.

[e] < port-list >

Same as the above command, but for the specified port(s). If a port is not configured as a supplicant, it does not appear in the listing.

[statistics]

Shows the port-access statistics and source MAC address(es) for all ports configured on the switch as supplicants. See the "Note", below.

[e] < port-list >

*Same as the above **statistics** command, but for the specified port(s). If a port is not configured as a supplicant, it does not appear in the listing.*

Note on Supplicant Statistics. For each port configured as a supplicant, **show port-access supplicant statistics [e] <port-list>** displays the source MAC address and statistics for transactions with the authenticator device most recently detected on the port. If the link between the supplicant port and the authenticator device fails, the supplicant port continues to show data from the connection to the most recent authenticator device until one of the following occurs:

- The supplicant port detects a different authenticator device
- You use the **aaa port-access supplicant [e] <port-list> clear-statistics** command to clear the statistics for the supplicant port
- The switch reboots

Thus, if the supplicant's link to the authenticator fails, the supplicant retains the most recent transaction statistics until one of the above events occurs. Also, if you move a link with an authenticator from one supplicant port to another without clearing the statistics data from the first port, the authenticator's MAC address will appear in the supplicant statistics for both ports.

How 802.1x Authentication Affects VLAN Operation

RADIUS authentication for an 802.1x client on a given port can include a (static) VLAN requirement. (Refer to the documentation provided with your RADIUS application.)

Static VLAN Requirement

The static VLAN to which a client is assigned must already exist on the switch. If it does not exist or is a dynamic VLAN (created by GVRP), authentication fails. Also, for the session to proceed, the port must be an untagged member of the required VLAN. If it is not, the switch temporarily reassigns the port as described below.

If the Port Used by the Client Is Not Configured as an Untagged Member of the Required Static VLAN: When a client is authenticated on port "N", if port "N" is not already configured as an untagged member of the static VLAN specified by the RADIUS server, then the switch temporarily assigns port "N" as an untagged member of the required VLAN (for the duration of the 802.1x session). *At the same time, if port "N" is already configured as*

an untagged member of another VLAN, port "N" loses access to that other VLAN for the duration of the session. (This is because a port can be an untagged member of only one VLAN at a time.)

For example, suppose that a RADIUS-authenticated, 802.1x-aware client on port A2 requires access to VLAN 22, but VLAN 22 is configured for no access on port A2, and VLAN 33 is configured as untagged on port A2:

```
===== CONSOLE - MANAGER MODE =====
Switch Configuration - VLAN - VLAN Port Assignment

Port  default_vlan  vlan_22  vlan_33  vlan_44
---- + - - - - -
A1   | Untagged    Tagged   No       No
A2   | No         No      Untagged No
A3   | Untagged    Forbid  Forbid   Forbid
A4   | Untagged    Tagged  Tagged   Tagged
  :   | :         :      :       :
  :   | :         :      :       :
  :   | :         :      :       :
Actions->  Cancel  Edit    Save    Help

Cancel changes and return to previous screen.
Use arrow keys to change action selection and <Enter> to execute.
```

Scenario: An authorized 802.1x client requires access to VLAN 22 from port A2. However, access to VLAN 22 is blocked (not untagged or tagged) on port A2 and

Figure 5-5. Example of an Active VLAN Configuration

In figure 5-5, if RADIUS authorizes an 802.1x client on port 2 with the requirement that the client use VLAN 22, then:

- VLAN 22 becomes available as Untagged on port 2 for the duration of the session.
- VLAN 33 becomes unavailable to port 2 for the duration of the session (because there can be only one untagged VLAN on any port).

You can use the **show vlan <vlan-id>** command to view this temporary change to the active configuration, as shown below:

- You can see the temporary VLAN assignment by using the **show vlan <vlan-id>** command with the **<vlan-id>** of the static VLAN that the authenticated client is using.

Configuring Port-Based Access Control (802.1x)
 How 802.1x Authentication Affects VLAN Operation

```

HPswitch(config)# show vlan 22
Status and Counters - VLAN Information - Ports - VLAN 22
802.1Q VLAN ID : 22
Name          : vlan_22
Status        : Static

Port Information Mode      Unknown VLAN Status
-----
A1                Tagged   Learn      Up
A2                802.1x  Learn      Up
A4                Tagged   Learn      Up
.                  .         .         .
.                  .         .         .
.                  .         .         .

Port VLAN membership configuration

Port  Mode
----  ---
A1    Tagged
A2    No
A4    Tagged
    
```

This entry shows that port A2 is temporarily untagged on VLAN 22 for an 802.1x session. This is to accommodate an 802.1x client's access, authenticated by a RADIUS server, where the server included an instruction to put the client's access on VLAN 22.

Note: With the current VLAN configuration (figure 5-5), the only time port A2 appears in this **show vlan 22** listing is during an 802.1x session with an attached client. Otherwise, port A2 is not listed.

Figure 5-6. The Active Configuration for VLAN 22 Temporarily Changes for the 802.1x Session

- With the preceding in mind, since (static) VLAN 33 is configured as untagged on port A2 (see figure 5-5), and since a port can be untagged on only one VLAN, port A2 loses access to VLAN 33 for the duration of the 802.1x session involving VLAN 22. You can verify the temporary loss of access to VLAN 33 with the **show vlan 33** command.

Even though port A2 is configured as Untagged on (static) VLAN 33 (see figure 5-5), it does not appear in the VLAN 33 listing while the 802.1x session is using VLAN 22 in the Untagged status. However, after the 802.1x session with VLAN 22 ends, the active configuration returns port A2 to VLAN 33.

```

HPswitch# show vlan 33
Status and Counters - VLAN Information - Ports - VLAN 33
802.1Q VLAN ID : 33
Name          : VLAN_33
Status        : Static

Port Information Mode      Unknown VLAN Status
-----
A4                Tagged   Learn      Up

Port VLAN membership configuration

Port Mode
----  ---
A2    Untagged
    
```

Figure 5-7. The Active Configuration for VLAN 33 Temporarily Drops Port 22 for the 802.1x Session

When the 802.1x client's session on port A2 ends, the port discards the temporary untagged VLAN membership. At this time the static VLAN actually configured as untagged on the port again becomes available. Thus, when the RADIUS-authenticated 802.1x session on port A2 ends, VLAN 22 access on port A2 also ends, and the untagged VLAN 33 access on port A2 is restored.

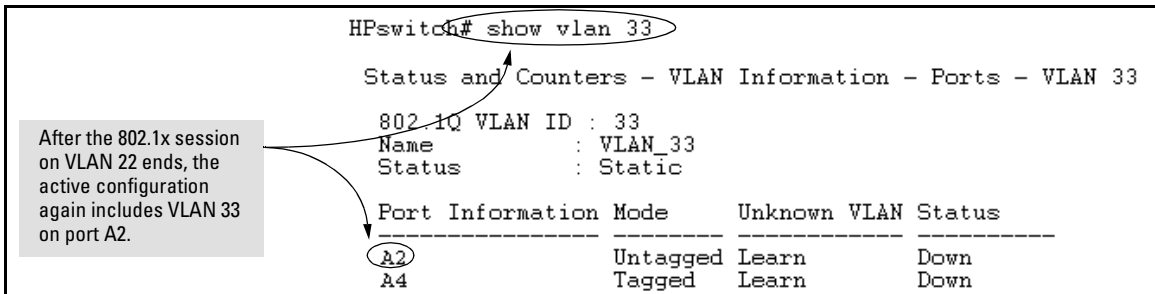

Figure 5-8. The Active Configuration for VLAN 33 Restores Port A2 After the 802.1x Session Ends

Notes

Any port VLAN-ID changes you make on 802.1x-aware ports during an 802.1x-authenticated session do not take effect until the session ends.

With GVRP enabled, a temporary, untagged static VLAN assignment created on a port by 802.1x authentication is advertised as an existing VLAN. If this temporary VLAN assignment causes the switch to disable a configured (untagged) static VLAN assignment on the port, then the disabled VLAN assignment is not advertised. When the 802.1x session ends, the switch:

- Eliminates and ceases to advertise the temporary VLAN assignment .
- Re-activates and resumes advertising the temporarily disabled VLAN assignment.

Messages Related to 802.1x Operation

Table 5-1. 802.1x Operating Messages

Message	Meaning
Port < <i>port-list</i> > is not an authenticator.	The ports in the port list have not been enabled as 802.1x authenticators. Use this command to enable the ports as authenticators: HPswitch(config)# aaa port-access authenticator e 10
Port < <i>port-list</i> > is not a supplicant.	Occurs when there is an attempt to change the supplicant configuration on a port that is not currently enabled as a supplicant. Enable the port as a supplicant and then make the desired supplicant configuration changes. Refer to "Enabling a Switch Port To Operate as a Supplicant" on page 5-18.
No server(s) responding.	This message can appear if you configured the switch for EAP-RADIUS or CHAP-RADIUS authentication, but the switch does not receive a response from a RADIUS server. Ensure that the switch is configured to access at least one RADIUS server. (Use show radius .) If you also see the message Can't reach RADIUS server < <i>x.x.x.x</i> >, try the suggestions listed for that message (page 3-29).
LACP has been disabled on 802.1x port(s) .	To maintain security, LACP is not allowed on ports configured for 802.1x authenticator operation. If you configure port security on a port on which LACP (active or passive) is configured, the switch removes the LACP configuration, displays a notice that LACP is disabled on the port(s), and enables 802.1x on that port.
Error configuring port < <i>port-number</i> > : LACP and 802.1x cannot be run together.	Also, the switch will not allow you to configure LACP on a port on which port access (802.1x) is enabled.

Configuring and Monitoring Port Security

Contents

Overview	6-2
Basic Operation	6-2
Blocking Unauthorized Traffic	6-3
Trunk Group Exclusion	6-4
Planning Port Security	6-5
Port Security Command Options and Operation	6-6
Retention of Static Addresses	6-8
Displaying Current Port Security Settings	6-9
Configuring Port Security	6-10
Web: Displaying and Configuring Port Security Features	6-15
Reading Intrusion Alerts and Resetting Alert Flags	6-15
Notice of Security Violations	6-15
How the Intrusion Log Operates	6-16
Keeping the Intrusion Log Current by Resetting Alert Flags	6-17
Menu: Checking for Intrusions, Listing Intrusion Alerts, and Resetting Alert Flags	6-17
CLI: Checking for Intrusions, Listing Intrusion Alerts, and Resetting Alert Flags	6-19
Using the Event Log To Find Intrusion Alerts	6-21
Web: Checking for Intrusions, Listing Intrusion Alerts, and Resetting Alert Flags	6-22
Operating Notes for Port Security	6-22

Overview

Feature	Default	Menu	CLI	Web
Displaying Current Port Security	n/a	—	page 6-9	page 6-15
Configuring Port Security	disabled	—	page 6-10	page 6-15
Intrusion Alerts and Alert Flags	n/a	page 6-21	page 6-19	page 6-22

Using Port Security, you can configure each switch port with a unique list of the MAC addresses of devices that are authorized to access the network through that port. This enables individual ports to detect, prevent, and log attempts by unauthorized devices to communicate through the switch.

Note

This feature does not prevent intruders from receiving broadcast and multi-cast traffic.

Basic Operation

Default Port Security Operation. The default port security setting for each port is off, or “continuous”. That is, any device can access a port without causing a security reaction.

Intruder Protection. A port that detects an “intruder” blocks the intruding device from transmitting to the network through that port.

General Operation for Port Security. On a per-port basis, you can configure security measures to block unauthorized devices, and to send notice of security violations. Once you have configured port security, you can then monitor the network for security violations through one or more of the following:

- Alert flags that are captured by network management tools such as HP TopTools for Hubs & Switches
- Alert Log entries in the switch's web browser interface
- Event Log entries in the console interface
- Intrusion Log entries in either the menu interface, CLI, or web browser interface

For any port, you can configure the following:

- **Authorized (MAC) Addresses:** Specify up to eight devices (MAC addresses) that are allowed to send inbound traffic through the port. This feature:
 - Closes the port to inbound traffic from any unauthorized devices that are connected to the port.
 - Provides the option for sending an SNMP trap notifying of an attempted security violation to a network management station and, optionally, disables the port. (For more on configuring the switch for SNMP management, see “Trap Receivers and Authentication Traps” in the *Management and Configuration Guide* for your switch.)

Blocking Unauthorized Traffic

Unless you configure the switch to disable a port on which a security violation is detected, the switch security measures block unauthorized traffic without disabling the port. This implementation enables you to apply the security configuration to ports on which hubs, switches, or other devices are connected, and to maintain security while also maintaining network access to authorized users. For example:

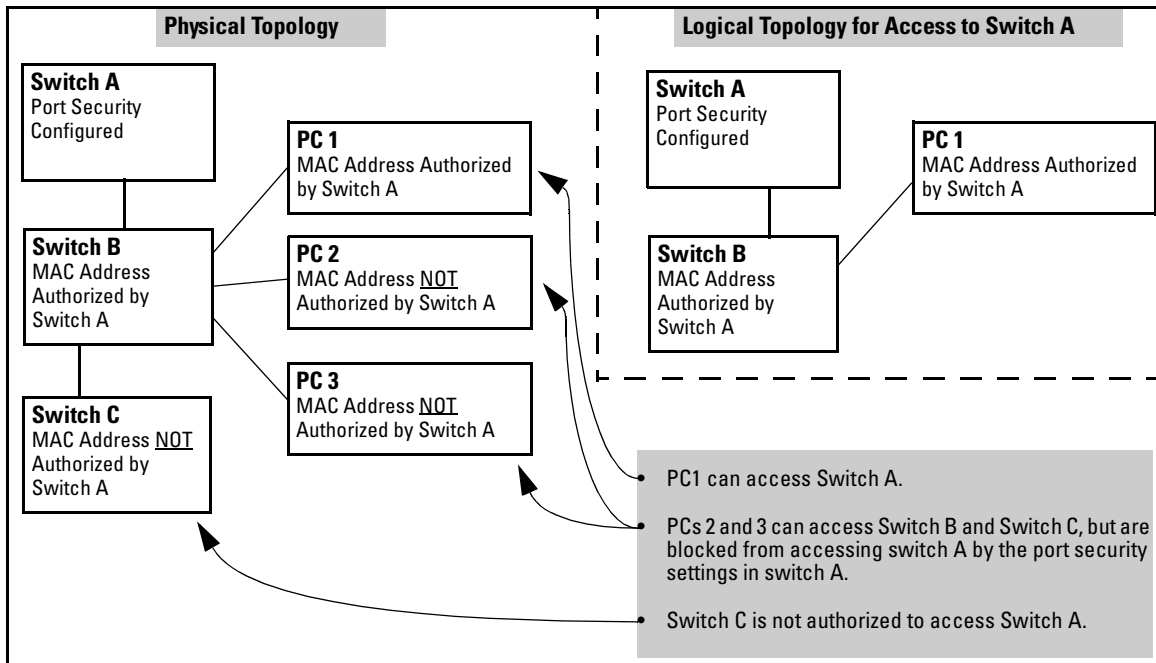

Figure 0-1. Example of How Port Security Controls Access

Note

Broadcast and Multicast traffic is not “unauthorized” traffic, and can be read by intruders connected to a port on which you have configured port security.

Trunk Group Exclusion

Port security does not operate on either a static or dynamic trunk group. If you configure port security on one or more ports that are later added to a trunk group, the switch will reset the port security parameters for those ports to the factory-default configuration. (Ports configured for either Active or Passive LACP, and which are not members of a trunk, can be configured for port security.)

Planning Port Security

1. Plan your port security configuration and monitoring according to the following:
 - a. On which ports do you want port security?
 - b. Which devices (MAC addresses) are authorized on each port (up to 8 per port)?
 - c. For each port, what security actions do you want? (The switch automatically blocks intruders detected on that port from transmitting to the network.) You can configure the switch to (1) send intrusion alarms to an SNMP management station and to (2) optionally disable the port on which the intrusion was detected.
 - d. How do you want to learn of the security violation attempts the switch detects? You can use one or more of these methods:
 - Through network management (That is, do you want an SNMP trap sent to a net management station when a port detects a security violation attempt?)
 - Through the switch's Intrusion Log, available through the CLI, menu, and web browser interface
 - Through the Event Log (in the menu interface or through the CLI **show log** command)
2. Use the CLI or web browser interface to configure port security operating and address controls. The following table describes the parameters.

Port Security Command Options and Operation

Port Security Commands Used in This Section

show port-security	6-9
port-security	6-10
< [ethernet] <i>port-list</i> >	6-10
[learn-mode]	6-10
[address-limit]	6-10
[mac-address]	6-10
[action]	6-10
[clear-intrusion-flag]	6-10
no port-security	6-10

This section describes the CLI port security command and how the switch acquires and maintains authorized addresses.

Note

Use the global configuration level to execute port-security configuration commands.

Table 6-1. Port Security Parameters

Parameter	Description
Port List	<code><[ethernet] port-list></code> Identifies the port or ports on which to apply a port security command.
Learn Mode	<p>learn-mode < static continuous port-access > Specifies how the port acquires authorized addresses:</p> <p>Continuous (Default): Appears in the factory-default setting or when you execute no port-security. Allows the port to learn addresses from inbound traffic from any device(s) to which it is connected. In this state, the port accepts traffic from any device(s) to which it is connected. Addresses learned this way appear in the switch and port address tables and age out according to the MAC Age Interval in the System Information configuration screen of the Menu interface or the show system-information listing.</p> <p>Static: Enables you to use the mac-address parameter to specify the MAC addresses of the devices authorized for a port, and the address-limit parameter to specify the number of MAC addresses authorized for the port. You can authorize specific devices for the port, while still allowing the port to accept other, non-specified devices until the device limit has been reached. That is, if you enter fewer MAC addresses than you authorized, the port authorizes the remaining addresses in the order in which it automatically learns them. For example, if you use address-limit to specify three authorized devices, but use mac-address to specify only one authorized MAC address, the port adds the one specifically authorized MAC address to its authorized-devices list and the first two additional MAC addresses it detects. If, for example:</p> <ul style="list-style-type: none"> – You use mac-address to authorize MAC address 0060b0-880a80 for port A4. – You use address-limit to allow three devices on port A4 and the port detects these MAC addresses: <ul style="list-style-type: none"> 1. 080090-1362f2 3. 080071-0c45a1 2. 00f031-423fc1 4. 0060b0-880a80 (the address you authorized with the mac-address parameter) <p>In the above case, port A4 would assume the following list of authorized addresses:</p> <ul style="list-style-type: none"> 080090-1362f2 (the first address the port detected) 00f031-423fc1 (the second address the port detected) 0060b0-880a80 (the address you authorized with the mac-address parameter) <p>The remaining MAC address the port detects, 080071-0c45a1, is not allowed, and is handled as an intruder.</p> <p>See also "Retention of Static Addresses" on the next page.</p> <p>Caution: When you use static with a device limit greater than the number of MAC addresses you specify with mac-address, an unwanted device can become "authorized". This can occur because the port, in order to fulfill the number of devices allowed by the address-limit parameter, automatically adds devices it detects until the specified limit is reached.</p> <p>Port-Access: Enables you to use Port Security with (802.1x) Port-Based Access Control. Refer to "Configuring Port-Based Access Control (802.1x)" on page 5-1.</p>
Address Limit	<p>address-limit <integer></p> <p>When Learn Mode is set to Static, specifies how many authorized devices (MAC addresses) to allow. Range: 1 (the default) to 8.</p>
MAC Address	<p>mac-address <mac-addr></p> <p>Available for static learn mode. Allows up to eight authorized devices (MAC addresses) per port, depending on the value specified in the address-limit parameter.</p> <p>If you use mac-address with static, but enter fewer devices than you specified in the address-limit field, the port accepts not only your specified devices, but also as many other devices as it takes to reach the device limit. For example, if you specify four devices, but enter only two MAC addresses, the port will accept the first two non-specified devices it detects, along with the two specifically authorized devices.</p>

Parameter	Description
Action	<p>action <none send-alarm send-disable></p> <p>Specifies whether an SNMP trap is sent to a network management station when Learn Mode is set to static and the port detects an unauthorized device, or when Learn Mode is set to continuous and there is an address change on a port.</p> <p>None (the default): Prevents an SNMP trap from being sent.</p> <p>Send Alarm: Causes the switch to send an SNMP trap to a network management station.</p> <p>Send Alarm and Disable: Available only in the static learn-mode. Causes the switch to send an SNMP trap to a network management station and disable the port. If you subsequently re-enable the port without clearing the port's intrusion flag, the port will block further intruders, but the switch will not disable the port again until you reset the intrusion flag. See the Note on 6-17.</p> <p>For information on configuring the switch for SNMP management, refer to the <i>Management and Configuration Guide</i> for your switch.</p>
Clear-Intrusion-Flag	<p>clear-intrusion-flag</p> <p>Clears the intrusion flag for a specific port. (See "Reading Intrusion Alerts and Resetting Alert Flags" on page 6-15.)</p>

Retention of Static Addresses

Learned Addresses. In the following two cases, a port in Static learn mode retains a learned MAC address even if you later reboot the switch or disable port security for that port:

- The port learns a MAC address after you configure the port for Static learn mode in both the startup-config file and the running-config file (by executing the write memory command).
- The port learns a MAC address after you configure the port for Static learn mode in only the running-config file and, after the address is learned, you execute write memory to configure the startup-config file to match the running-config file.

To remove an address learned using either of the preceding methods, do one of the following:

- Delete the address by using **no port-security < port-number > mac-address < mac-addr >**.
- Download a configuration file that does not include the unwanted MAC address assignment.
- Reset the switch to its factory-default configuration.

Assigned/Authorized Addresses. : If you manually assign a MAC address (using **port-security <port-number> address-list <mac-addr>**) and then execute **write memory**, the assigned MAC address remains in memory until you do one of the following:

- Delete it by using **no port-security <port-number> mac-address <mac-addr>**.
- Download a configuration file that does not include the unwanted MAC address assignment.
- Reset the switch to its factory-default configuration.

Displaying Current Port Security Settings

The CLI uses the same command to provide two types of port security listings:

- All ports on the switch with their Learn Mode and (alarm) Action
- Only the specified ports with their Learn Mode, Address Limit, (alarm) Action, and Authorized Addresses

Using the CLI To Display Port Security Settings.

Syntax: show port-security
show port-security [e] <port number>
show port-security [e] [<port number>-<port number>] . . . [<port number>]

Without port parameters, **show port-security** displays Operating Control settings for all ports on a switch. For example:

```
HPswitch(config)# show port-security
Port Security
  Port Learn Mode | Action
  ---- +-----
  A1 1 Static      | Send Alarm, Disable Port
  A2 2 Static      | Send Alarm, Disable Port
  A3 3 Static      | Send Alarm
  A4 4 Static      | Send Alarm
  A5 5 Static      | Send Alarm
  A6 6 Static      | Send Alarm
  A7 7 Continuous | None
  A8 8 Continuous | None
```

Figure 6-2. Example Port Security Listing (Ports A7 and A8 Show the Default Setting)

With port numbers included in the command, **show port-security** displays Learn Mode, Address Limit, (alarm) Action, and Authorized Addresses for the specified ports on a switch. The following example lists the full port security configuration for a single port:

```
HPswitch(config)# show port-security A3
Port Security
  Port : A3
  Learn Mode : Static           Address Limit : 1
  Action : Send Alarm
  Authorized Addresses
  -----
  00906d-fdce00
```

Figure 6-3. Example of the Port Security Configuration Display for a Single Port

The following command example shows the option for entering a range of ports, including a series of non-contiguous ports. Note that no spaces are allowed in the port number portion of the command string:

```
HPswitch(config)# show port-security A1-A3,A6,A8
```

Configuring Port Security

Using the CLI, you can:

- Configure port security and edit security settings.
- Add or delete devices from the list of authorized addresses for one or more ports.
- Clear the Intrusion flag on specific ports

Syntax: port-security [e]<port-list>
[learn-mode < continuous | static | port-access >]
[address-limit <integer>]
[mac-address <mac-addr>] [<mac-addr> ... <mac-addr>]
[action < none | send-alarm | send-disable >]
[clear-intrusion-flag]

no port-security <port-list> mac-address <mac-addr> [<mac-addr> ... <mac-addr>]

For information on the individual control parameters, see the Port Security Parameter table on page 6-7.

Specifying Authorized Devices and Intrusion Responses. This example configures port A1 to automatically accept the first device (MAC address) it detects as the only authorized device for that port. (The default device limit is 1.) It also configures the port to send an alarm to a network management station and disable itself if an intruder is detected on the port.

```
HPswitch(config)# port-security a1 learn-mode static  
action send-disable
```

The next example does the same as the preceding example, except that it specifies a MAC address of 0c0090-123456 as the authorized device instead of allowing the port to automatically assign the first device it detects as an authorized device.

```
HPswitch(config)# port-security a1 learn-mode static  
mac-address 0c0090-123456 action send-disable
```

This example configures port A5 to:

- Allow two MAC addresses, 00c100-7fec00 and 0060b0-889e00, as the authorized devices
- Send an alarm to a management station if an intruder is detected on the port

```
HPswitch(config)# port-security a5 learn-mode static  
address-limit 2 mac-address 00c100-7fec00 0060b0-889e00  
action send-alarm
```

If you manually configure authorized devices (MAC addresses) and/or an alarm action on a port, those settings remain unless you either manually change them or the switch is reset to its factory-default configuration. You can “turn off” authorized devices on a port by configuring the port to continuous Learn Mode, but subsequently reconfiguring the port to static Learn Mode restores those authorized devices.

Adding an Authorized Device to a Port. To simply add a device (MAC address) to a port’s existing Authorized Addresses list, enter the port number with the **mac-address** parameter and the device’s MAC address. *This assumes that Learn Mode is set to **static** and the Authorized Addresses list is not full* (as determined by the current Address Limit value). For example, suppose port A1 allows two authorized devices, but has only one device in its Authorized Address list:

```
HPswitch(config)# show port-security a1
Port Security
  Port : A1
  Learn Mode [Continuous] : Static      Address Limit [1] : 2
  Action [None] : None

  Authorized Addresses
  -----
  0c0090-123456
```

Although the Address Limit is set to 2, only one device has been authorized for this port. In this case you can add another without having to also increase the Address Limit.

The Address Limit has not been reached.

Figure 6-4. Example of Adding an Authorized Device to a Port

With the above configuration for port A1, the following command adds the 0c0090-456456 MAC address as the second authorized address.

```
HPswitch(config)# port-security a1 mac-address 0c0090-456456
```

After executing the above command, the security configuration for port A1 would be:

```
HPswitch(config)# show port-security a1
Port Security
  Port : A1
  Learn Mode [Continuous] : Static      Address Limit [1] : 2
  Action [None] : None

  Authorized Addresses
  -----
  0c0090-123456
  0c0090-456456
```

The Address Limit has been reached.

Figure 6-5. Example of Adding a Second Authorized Device to a Port

(The message **Inconsistent value** appears if the new MAC address exceeds the current Address Limit or specifies a device that is already on the list. Note that if you change a port from static to continuous learn mode, the port retains in memory any authorized addresses it had while in static mode. If you subsequently attempt to convert the port back to static mode with the same authorized address(es), the **Inconsistent value** message appears because the port already has the address(es) in its “Authorized” list.)

If you are adding a device (MAC address) to a port on which the Authorized Addresses list is already full (as controlled by the port's current Address Limit setting), then you must increase the Address Limit in order to add the device, even if you want to replace one device with another. Using the CLI, you can simultaneously increase the limit and add the MAC address with a single command. For example, suppose port A1 allows one authorized device and already has a device listed:

```
HPswitch(config)# show port-security a1
Port Security
  Port : A1
  Learn Mode [Continuous] : Static   Address Limit [1]:1
  Action [None] : None

  Authorized Addresses
  -----
  0c0090-123456
```

Figure 6-6. Example of Port Security on Port A1 with an Address Limit of "1"

To add a second authorized device to port A1, execute a **port-security** command for for port A1 that raises the address limit to 2 and specifies the additional device's MAC address. For example:

```
HPswitch(config)# port-security a1 mac-address 0c0090-
456456 address-limit 2
```

Removing a Device From the “Authorized” List for a Port. This command option removes unwanted devices (MAC addresses) from the Authorized Addresses list. (An Authorized Address list is available for each port for which Learn Mode is currently set to “Static”. See the “MAC Address” entry in the table on page 6-7.)

Caution

When learn mode is set to static, the Address Limit (address-limit) parameter controls how many devices are allowed in the Authorized Addresses (**mac-address**) for a given port. If you remove a MAC address from the Authorized Addresses list without also reducing the Address Limit by 1, the port may subsequently detect and accept as authorized a MAC address that you do not intend to include in your Authorized Address list. Thus, if you use the CLI to remove a device that is no longer authorized, it is recommended that you first reduce the Address Limit (**address-limit**) integer by 1, as shown below. This prevents the possibility of the same device or another unauthorized device on the network from automatically being accepted as “authorized” for that port.

To remove a device (MAC address) from the “Authorized” list and when the current number of devices equals the Address Limit value, you should first reduce the Address Limit value by 1, then remove the unwanted device.

Note

You can reduce the address limit below the number of currently authorized addresses on a port. This enables you to subsequently remove a device from the “Authorized” list without opening the possibility for an unwanted device to automatically become authorized.

For example, suppose port A1 is configured as shown below and you want to remove 0c0090-123456 from the Authorized Address list:

```
HPswitch(config)# show port-security a1
Port Security
  Port : A1
  Learn Mode [Continuous] : Static      Address Limit [1] : 2
  Action [None] : None

  Authorized Addresses
  -----
  0c0090-123456
  0c0090-456456
```

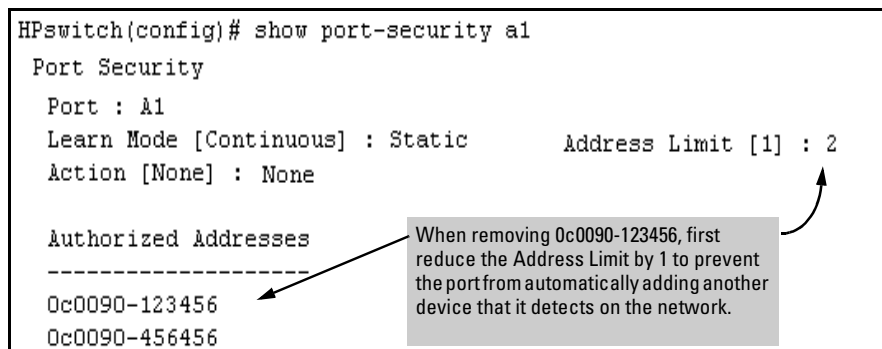

Figure 6-7. Example of Two Authorized Addresses on Port A1

The following command serves this purpose by removing 0c0090-123456 and reducing the Address Limit to 1:

```
HPswitch(config)# port-security a1 address-limit 1
HPswitch(config)# no port-security a1 mac-address 0c0090-123456
```

The above command sequence results in the following configuration for port A1:

```
HPswitch(config)# show port-sec a1
Port Security
  Port : A1
  Learn Mode : Static      Address Limit : 1
  Action : None
  Authorized Addresses
  -----
  0c0090-456456
```

Figure 6-8. Example of Port A1 After Removing One MAC Address

Web: Displaying and Configuring Port Security Features

1. Click on the **Security** tab.
2. Click on `Port Security`.
3. Select the settings you want and, if you are using the Static Learn Mode, add or edit the Authorized Addresses field.
4. Implement your new data by clicking on `Apply Changes`.

To access the web-based Help provided for the switch, click on `?` in the web browser screen.

Reading Intrusion Alerts and Resetting Alert Flags

Notice of Security Violations

When the switch detects an intrusion on a port, it sets an “alert flag” for that port and makes the intrusion information available as described below. *While the switch can detect additional intrusions for the same port, it does not list the next chronological intrusion for that port in the Intrusion Log until the alert flag for that port has been reset.*

When a security violation occurs on a port configured for Port Security, the switch responds in the following ways to notify you:

- The switch sets an alert flag for that port. This flag remains set until:
 - You use either the CLI, menu interface, or web browser interface to reset the flag.
 - The switch is reset to its factory default configuration.
- The switch enables notification of the intrusion through the following means:
 - In the CLI:

- The **show port-security intrusion-log** command displays the Intrusion Log
- The **log** command displays the Event Log
- In the menu interface:
 - The Port Status screen includes a per-port intrusion alert
 - The Event Log includes per-port entries for security violations
- In the web browser interface:
 - The Alert Log's Status | Overview window includes entries for per-port security violations
 - The Intrusion Log in the Security | Intrusion Log window lists per-port security violation entries
- In HP TopTools for Hubs & Switches via an SNMP trap sent to a net management station

How the Intrusion Log Operates

When the switch detects an intrusion attempt on a port, it enters a record of this event in the Intrusion Log. No further intrusion attempts on that port will appear in the Log until you acknowledge the earlier intrusion event by resetting the alert flag.

The Intrusion Log lists the 20 most recently detected security violation attempts, regardless of whether the alert flags for these attempts have been reset. This gives you a history of past intrusion attempts. Thus, for example, if there is an intrusion alert for port A1 and the Intrusion Log shows two or more entries for port 1, only the most recent entry has not been acknowledged (by resetting the alert flag). The other entries give you a history of past intrusions detected on port A1.

```
Status and Counters - Intrusion Log
```

Port	MAC Address	Date / Time
A1	080009-e93d4f	03/07/02 21:09:34
A1	080009-e93d4f	03/07/02 10:18:43

Figure 6-9. Example of Multiple Intrusion Log Entries for the Same Port

The log shows the most recent intrusion at the top of the listing. You cannot delete Intrusion Log entries (unless you reset the switch to its factory-default configuration). Instead, if the log is filled when the switch detects a new intrusion, the oldest entry is dropped off the listing and the newest entry appears at the top of the listing.

Keeping the Intrusion Log Current by Resetting Alert Flags

When a violation occurs on a port, an alert flag is set for that port and the violation is entered in the Intrusion Log. The switch can detect and handle subsequent intrusions on that port, but will not log another intrusion on the port until you reset the alert flag for either all ports or for the individual port.

Note on Send-Disable Operation

On a given port, if the intrusion action is to send an SNMP trap and then disable the port (**send-disable**), and the an intruder is detected on the port, then the switch sends an SNMP trap, sets the port's alert flag, and disables the port. If you re-enable the port without resetting the port's alert flag, then the port operates as follows:

- The port comes up and will block traffic from unauthorized devices it detects.
- If the port detects another intruder, it will send another SNMP trap, but will not become disabled again unless you first reset the port's intrusion flag.

This operation enables the port to continue passing traffic for authorized devices while you take the time to locate and eliminate the intruder. Otherwise, the presence of an intruder could cause the switch to repeatedly disable the port.

Menu: Checking for Intrusions, Listing Intrusion Alerts, and Resetting Alert Flags

The menu interface indicates per-port intrusions in the Port Status screen, and provides details and the reset function in the Intrusion Log screen.

1. From the Main Menu select:

1. **Status and Counters**
4. **Port Status**

Configuring and Monitoring Port Security

Reading Intrusion Alerts and Resetting Alert Flags

The Intrusion Alert column shows "Yes" for any port on which a security violation has been detected.

```
===== CONSOLE - MANAGER MODE =====
                          Status and Counters - Port Status
-----
Port      Type      Intrusion  Enabled  Status  Mode      Flow
         Type      Alert      Enabled  Status  Mode      Ctrl
-----
A1       10/100TX  No         Yes      Up      Auto      off
A2       10/100TX  No         Yes      Up      Auto      off
A3       10/100TX  Yes        Yes      Up      Auto      off
A4       10/100TX  No         Yes      Up      Auto      off
A5       10/100TX  No         Yes      Up      Auto      off
A6       10/100TX  No         Yes      Down    Auto      off
A7       10/100TX  No         Yes      Up      Auto      off
A8       10/100TX  No         Yes      Down    Auto      off
-----
Actions->  Back      Intrusion log  Help

Return to previous screen.
Use up/down arrow keys to scroll to other entries, left/right arrow keys to
change action selection, and <Enter> to execute action.
```

Figure 6-10. Example of Port Status Screen with Intrusion Alert on Port A3

2. Type **I** (Intrusion log) to display the Intrusion Log.

MAC Address of Intruding Device on Port A3

```
===== CONSOLE - MANAGER MODE =====
                          Status and Counters - Intrusion Log
-----
Port      MAC Address      Date / Time      System Time of Intrusion on Port A3
-----
A3       080009-6563e2    08/08/02 16:58:02
A1       0060b0-896e00    08/08/02 15:28:21
A3       080009-cf558f    prior to 08/08/02 10:28:58
-----
Actions->  Back      Reset alert flags  Help

Return to previous screen.
Use up/down arrow keys to scroll to other entries, left/right arrow keys to
change action selection, and <Enter> to execute action.
```

Indicates this intrusion on port A3 occurred prior to a reset (reboot) at the indicated time and date.

Figure 6-11. Example of the Intrusion Log Display

The above example shows two intrusions for port A3 and one intrusion for port A1. In this case, only the most recent intrusion at port A3 has not been acknowledged (reset). This is indicated by the following:

- Because the Port Status screen (figure 6-10 on page 6-18) does not indicate an intrusion for port A1, the alert flag for the intrusion on port A1 has already been reset.
- Since the switch can show only one uncleared intrusion per port, the older intrusion for port A3 in this example has also been previously reset.

(The intrusion log holds up to 20 intrusion records and deletes an intrusion record only when the log becomes full and a new intrusion is subsequently detected.)

Note also that the “**prior to**” text in the record for the earliest intrusion means that a switch reset occurred at the indicated time and that the intrusion occurred prior to the reset.

3. To acknowledge the most recent intrusion entry on port A3 and enable the switch to enter a subsequently detected intrusion on this port, type **[R]** (for **Reset alert flags**). (Note that if there are unacknowledged intrusions on two or more ports, this step resets the alert flags for all such ports.)

If you then re-display the port status screen, you will see that the Intrusion Alert entry for port A3 has changed to “**No**”. That is, your evidence that the Intrusion Alert flag has been acknowledged (reset) is that the Intrusion Alert column in the port status display no longer shows “**Yes**” for the port on which the intrusion occurred (port A3 in this example). (Because the Intrusion Log provides a history of the last 20 intrusions detected by the switch, resetting the alert flags does not change its content. Thus, displaying the Intrusion Log again will result in the same display as in figure 6-11, above.)

CLI: Checking for Intrusions, Listing Intrusion Alerts, and Resetting Alert Flags

The following commands display port status, including whether there are intrusion alerts for any port(s), list the last 20 intrusions, and either reset the alert flag on all ports or for a specific port for which an intrusion was detected. (The record of the intrusion remains in the log. For more information, refer to “Operating Notes for Port Security” on page 6-22.)

Syntax: show interfaces brief

List intrusion alert status (and other port status information).

show port-security intrusion-log

List intrusion log content.

clear intrusion-flags

Clear intrusion flags on all ports.

port-security [e] < port-number > clear-intrusion-flag

Clear the intrusion flag on one or more specific ports.

In the following example, executing **show interfaces brief** lists the switch’s port status, which indicates an intrusion alert on port A1.

```

HPswitch# show interfaces brief
Status and Counters - Port Status

```

Port	Type	Intrusion Alert	Enabled	Status	Mode	Flow Ctrl
A1	10/100TX	Yes	Yes	Up	10HDx	off
A2	10/100TX	No	Yes	Up	10HDx	off
A3	10/100TX	No	Yes	Up	10HDx	off
A4	10/100TX	No	Yes	Up	10HDx	off

Intrusion Alert on port A1.

Figure 6-12. Example of an Unacknowledged Intrusion Alert in a Port Status Display

If you wanted to see the details of the intrusion, you would then enter the **show port-security intrusion-log** command. For example:

```

HPswitch# show port-security intrusion-log
Status and Counters - Intrusion Log

```

Port	MAC Address	Date / Time
A1	080009-e93d4f	07/03/02 21:09:34
A1	080009-21ae84	07/03/02 17:26:27
A1	080009-e93d4f	prior to 07/03/02 17:18:43

0 secs
0 secs

MAC Address of latest Intruder on Port A1

Dates and Times of Intrusions

Earlier intrusions on port A1 that have already been cleared (that is, the Alert Flag has been reset at least twice before the most recent intrusion occurred).

Figure 6-13. Example of the Intrusion Log with Multiple Entries for the Same Port

The above example shows three intrusions for port A1. Since the switch can show only one uncleared intrusion per port, the older two intrusions in this example have already been cleared by earlier use of the **clear intrusion-log** or the **port-security < port-list > clear-intrusion-flag** command. (The intrusion log holds up to 20 intrusion records, and deletes intrusion records only when the log becomes full and new intrusions are subsequently added.) The “**prior to**” text in the record for the third intrusion means that a switch reset occurred at the indicated time and that the intrusion occurred prior to the reset.

To clear the intrusion from port A1 and enable the switch to enter any subsequent intrusion for port A1 in the Intrusion Log, execute the **port-security clear-intrusion-flag** command. If you then re-display the port status screen, you will see that the Intrusion Alert entry for port A1 has changed to “**No**”. (Executing **show port-security intrusion-log** again will result in the same display as above, and does not include the Intrusion Alert status.)

```

HPswitch(config)# port-security a1 clear-intrusion-flag
HPswitch(config)# show interfaces brief

```

Intrusion Alert on port A1 is now cleared.

```
Status and Counters - Port Status
```

Port	Type	Intrusion Alert	Enabled	Status	Mode	Flow Ctrl	Bcast Limit
A1	10/100TX	No	Yes	Up	10HDx	off	0
A2	10/100TX	No	Yes	Up	10HDx	off	0
A3	10/100TX	No	Yes	Up	10HDx	off	0

Figure 6-14. Example of Port Status Screen After Alert Flags Reset

For more on clearing intrusions, see “Note on Send-Disable Operation” on page 6-17

Using the Event Log To Find Intrusion Alerts

The Event Log lists port security intrusions as:

```
W MM/DD/YY HH:MM:SS FFI: port A3 - Security Violation
```

where “W” is the severity level of the log entry and **FFI** is the system module that generated the entry. For further information, display the Intrusion Log, as shown below.

From the CLI. Type the **log** command from the Manager or Configuration level.

Syntax: `log < search-text >`

For **< search-text >**, you can use **ffi**, **security**, or **violation**. For example:

<p>Log Listing with Security Violation Detected</p>	<pre>HPswitch(config)# log security Keys: W=Warning I=Information M=Major D=Debug ---- Event Log listing: Events Since Boot ---- W 08/01/02 01:18:15 FFI: port A2 - Security Violation W 08/01/02 04:28:08 FFI: port A1 - Security Violation ---- Bottom of Log : Events Listed = 2 ----</pre>	<p>Log Command with “security” for Search String</p>
<p>Log Listing with No Security Violation Detected</p>	<pre>HPswitch(config)# log security Keys: W=Warning I=Information M=Major D=Debug ---- Event Log listing: Events Since Boot ---- ---- Bottom of Log : Events Listed = 0 ----</pre>	

Figure 6-15. Example of Log Listing With and Without Detected Security Violations

From the Menu Interface: In the Main Menu, click on **4. Event Log** and use **Next page** and **Prev page** to review the Event Log contents.

For More Event Log Information. See “Using the Event Log To Identify Problem Sources” in the “Troubleshooting” chapter of the *Management and Configuration Guide* for your switch.

Web: Checking for Intrusions, Listing Intrusion Alerts, and Resetting Alert Flags

1. Check the Alert Log by clicking on the **Status** tab and the Overview button. If there is a “Security Violation” entry, do the following:
 - a. Click on the **Security** tab.
 - b. Click on Intrusion Log. “Ports with Intrusion Flag” indicates any ports for which the alert flag has not been cleared.
 - c. To clear the current alert flags, click on Reset Alert Flags.

To access the web-based Help provided for the switch, click on ? in the web browser screen.

Operating Notes for Port Security

Identifying the IP Address of an Intruder. The Intrusion Log lists detected intruders by MAC address. If you are using HP TopTools for Hubs & Switches to manage your network, you can use the TopTools inventory reports to link MAC addresses to their corresponding IP addresses. (Inventory reports are organized by device type; hubs, switches, servers, etc.)

Proxy Web Servers. If you are using the switch’s web browser interface through a switch port configured for Static port security, and your browser access is through a proxy web server, then it is necessary to do the following:

- Enter your PC or workstation MAC address in the port’s Authorized Addresses list.
- Enter your PC or workstation’s IP address in the switch’s IP Authorized Managers list. See “Using Authorized IP Managers” in the *Management and Configuration Guide* for your switch.)

Without both of the above configured, the switch detects only the proxy server's MAC address, and not your PC or workstation MAC address, and interprets your connection as unauthorized.

“Prior To” Entries in the Intrusion Log. If you reset the switch (using the Reset button, Device Reset, or Reboot Switch), the Intrusion Log will list the time of all currently logged intrusions as “prior to” the time of the reset.

Alert Flag Status for Entries Forced Off of the Intrusion Log. If the Intrusion Log is full of entries for which the alert flags have not been reset, a new intrusion will cause the oldest entry to drop off the list, but will not change the alert flag status for the port referenced in the dropped entry. This means that, even if an entry is forced off of the Intrusion Log, no new intrusions can be logged on the port referenced in that entry until you reset the alert flags.

LACP Not Available on Ports Configured for Port Security. To maintain security, LACP is not allowed on ports configured for port security. If you configure port security on a port on which LACP (active or passive) is configured, the switch removes the LACP configuration, displays a notice that LACP is disabled on the port(s), and enables port security on that port. For example:

```
HPswitch(config)# port-security e a17 learn-mode static
address-limit 2
LACP has been disabled on secured port(s).
HPswitch(config)#
```

The switch will not allow you to configure LACP on a port on which port security is enabled. For example:

```
HPswitch(config)# int e a17 lacp passive
Error configuring port A17: LACP and port security cannot
be run together.
HPswitch(config)#
```

To restore LACP to the port, you must remove port security and re-enable LACP active or passive.

Using Authorized IP Managers

Contents

Overview	7-2
Options	7-3
Access Levels	7-3
Defining Authorized Management Stations	7-4
Overview of IP Mask Operation	7-4
Menu: Viewing and Configuring IP Authorized Managers	7-5
CLI: Viewing and Configuring Authorized IP Managers	7-6
Listing the Switch's Current Authorized IP Manager(s)	7-6
Configuring IP Authorized Managers for the Switch	7-7
Web: Configuring IP Authorized Managers	7-8
Building IP Masks	7-9
Configuring One Station Per Authorized Manager IP Entry	7-9
Configuring Multiple Stations Per Authorized Manager IP Entry ...	7-10
Additional Examples for Authorizing Multiple Stations	7-12
Operating and Troubleshooting Notes	7-12

Overview

Authorized IP Manager Features

Feature	Default	Menu	CLI	Web
Listing (Showing) Authorized Managers	n/a	page 7-5	page 7-6	page 7-8
Configuring Authorized IP Managers	None	page 7-5	page 7-6	page 7-8
Building IP Masks	n/a	page 7-9	page 7-9	page 7-9
Operating and Troubleshooting Notes	n/a	page 7-12	page 7-12	page 7-12

The Authorized IP Managers feature enhances security on the switch by using IP addresses and masks to determine which stations (PCs or workstations) can access the switch through the network. This covers access through the following means:

- Telnet and other terminal emulation applications
- The switch’s web browser interface
- SNMP (with a correct community name)
- File transfers using TFTP (for configurations and software updates)

Also, when configured in the switch, the Authorized IP Managers feature takes precedence over local passwords, TACACS+, RADIUS, Port-Based Access Control (802.1x), and Port Security. This means that the IP address of a networked management device must be authorized before the switch will attempt to authenticate the device by invoking any other access security features. If the Authorized IP Managers feature disallows access to the device, then access is denied. Thus, with authorized IP managers configured, having the correct passwords is not sufficient for accessing the switch through the network unless the station attempting access is also included in the switch’s Authorized IP Managers configuration.

You can use Authorized IP Managers along with other access security features to provide a more comprehensive security fabric than if you use only one or two security options. Refer to table 1, “Management Access Security Protection” (page xi) for a listing of access security features with the security coverage they provide.

Options

You can configure:

- Up to 10 authorized manager *addresses*, where each address applies to either a single management station or a group of stations
- Manager or Operator access privileges

Caution

Configuring Authorized IP Managers does not protect access to the switch through a modem or direct connection to the Console (RS-232) port. Also, if the IP address assigned to an authorized management station is configured in another station, the other station can gain management access to the switch even though a duplicate IP address condition exists. For these reasons, you should enhance your network's security by keeping physical access to the switch restricted to authorized personnel, using the TACACS+ and username/password features built into the switch, and preventing unauthorized access to data on your management stations.

Access Levels

For each authorized manager address, you can configure either of these access levels:

- **Manager:** Enables full access to all web browser and console interface screens for viewing, configuration, and all other operations available in these interfaces.
- **Operator:** Allows read-only access from the web browser and console interfaces. (This is the same access that is allowed by the switch's operator-level password feature.)

Defining Authorized Management Stations

- **Authorizing Single Stations:** The table entry authorizes a single management station to have IP access to the switch. To use this method, just enter the IP address of an authorized management station in the Authorized Manager IP column, and leave the IP Mask set to **255.255.255.255**. This is the easiest way to use the Authorized Managers feature. (For more on this topic, see “Configuring One Station Per Authorized Manager IP Entry” on page 7-9.)
- **Authorizing Multiple Stations:** The table entry uses the IP Mask to authorize access to the switch from a defined group of stations. This is useful if you want to easily authorize several stations to have access to the switch without having to type in an entry for every station. All stations in the group defined by the one Authorized Manager IP table entry and its associated IP mask will have the same access level—Manager or Operator. (For more on this topic, refer to “Configuring Multiple Stations Per Authorized Manager IP Entry” on page 7-10.)

To configure the switch for authorized manager access, enter the appropriate *Authorized Manager IP* value, specify an *IP Mask*, and select either **Manager** or **Operator** for the *Access Level*. The IP Mask determines how the Authorized Manager IP value is used to allow or deny access to the switch by a management station.

Overview of IP Mask Operation

The default IP Mask is 255.255.255.255 and allows switch access only to a station having an IP address that is identical to the Authorized Manager IP parameter value. (“255” in an octet of the mask means that only the exact value in the corresponding octet of the Authorized Manager IP parameter is allowed in the IP address of an authorized management station.) However, you can alter the mask and the Authorized Manager IP parameter to specify ranges of authorized IP addresses. For example, a mask of **255.255.255.0** and any value for the Authorized Manager IP parameter allows a range of 0 through 255 in the 4th octet of the authorized IP address, which enables a block of up to 254 IP addresses for IP management access (excluding 0 for the network and 255 for broadcasts). A mask of **255.255.255.252** uses the 4th octet of a given Autho-

rized Manager IP address to authorize four IP addresses for management station access. The details on how to use IP masks are provided under “Building IP Masks” on page 7-9.

Note

The IP Mask is a method for recognizing whether a given IP address is authorized for management access to the switch. This mask serves a different purpose than IP subnet masks and is applied in a different manner.

Menu: Viewing and Configuring IP Authorized Managers

From the console Main Menu, select:

2. Switch Configuration . . .

7. IP Authorized Managers

```
----- TELNET - MANAGER MODE -----
Switch Configuration - IP Managers

Authorized Manager IP      IP Mask      Access Level
-----
13.28.227.101             255.255.255.252  Manager
13.28.227.104             255.255.255.254  Manager
13.28.227.106             255.255.255.0    Operator
13.28.227.125             255.255.255.255  Manager

Actions->  Back  Add  Edit  Delete  Help
Return to previous screen.
Use up/down arrow keys to change record selection, left/right arrow keys to
change action selection, and <Enter> to execute action.
```

Figure 7-1. Example of How To Add an Authorized Manager Entry

Using Authorized IP Managers

Defining Authorized Management Stations

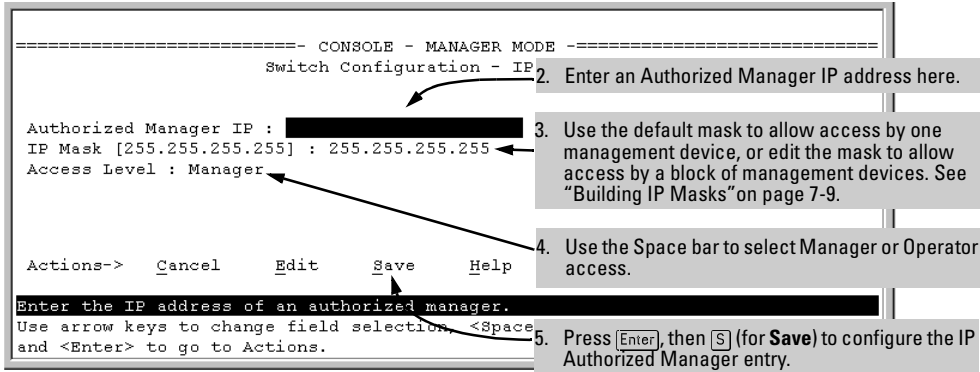

Figure 7-2. Example of How To Add an Authorized Manager Entry (Continued)

Editing or Deleting an Authorized Manager Entry. Go to the IP Managers List screen (figure 7-1), highlight the desired entry, and press **[E]** (for **Edit**) or **[D]** (for **Delete**).

CLI: Viewing and Configuring Authorized IP Managers

Authorized IP Managers Commands Used in This Section

Command	Page
show ip authorized-managers	below
ip authorized-managers	7-7
<ip-address>	7-8
mask <mask-bits>	7-8
<operator manager>	

Listing the Switch's Current Authorized IP Manager(s)

Use the **show ip authorized-managers** command to list IP stations authorized to access the switch. For example:

```
HPswitch show ip authorized-managers
IP Managers
Authorized Manager IP  IP Mask  Access Level
-----
10.28.227.101         255.255.255.252  Manager
10.28.227.104         255.255.255.254  Manager
10.28.227.125         255.255.255.255  Manager
10.28.227.106         255.255.255.0    Operator
```

Figure 7-3. Example of the Show IP Authorized-Manager Display

The above example shows an Authorized IP Manager List that allows stations to access the switch as shown below:

IP Mask	Authorized Station IP Address:	Access Mode:
255.255.255.252	10.28.227.100 through 103	Manager
255.255.255.254	10.28.227.104 through 105	Manager
255.255.255.255	10.28.227.125	Manager
255.255.255.0	10.28.227.0 through 255	Operator

Configuring IP Authorized Managers for the Switch

Syntax: ip authorized-managers <ip address>

Configures one or more authorized IP addresses.

[mask <mask-bits>]

Configures the IP mask for <ip address >

<operator | manager>

Configures the privilege level for <ip address>.

To Authorize Manager Access. This command authorizes manager-level access for any station having an IP address of 10.28.227.0 through 10.28.227.255:

```
HPswitch(config)# ip authorized-managers 10.28.227.101  
mask 255.255.255.0 manager
```

Similarly, the next command authorizes manager-level access for any station having an IP address of 10.28.227.101 through 103:

```
HPswitch(config)# ip authorized-managers 10.28.227.101  
mask 255.255.255.252 manager
```

If you omit the mask when adding a new authorized manager, the switch automatically uses **255.255.255.255** for the mask. If you do not specify either Manager or Operator access, the switch automatically assigns the Manager access. For example:

```
HPswitch(config)# ip authorized-managers 10.28.227.105
```

The result of entering the preceding example is:

- Authorized Station IP Address: 10.28.227.105
- IP Mask: 255.255.255.255, which authorizes only the specified station (10.28.227.105 in this case). (See “Configuring Multiple Stations Per Authorized Manager IP Entry” on page 7-10.)
- Access Level: Manager

To Edit an Existing Manager Access Entry. To change the mask or access level for an existing entry, use the entry’s IP address and enter the new value(s). (Notice that any parameters not included in the command will be set to their default.):

```
HPswitch(config)# ip authorized-managers  
10.28.227.101 mask 255.255.255.0 operator
```

The above command replaces the existing mask and access level for IP address 10.28.227.101 with 255.255.255.0 and operator.

The following command replaces the existing mask and access level for IP address 10.28.227.101 with 255.0.0.0 and manager (the defaults) because the command does not specify either of these parameters .

```
HPswitch(config)# ip authorized-managers 10.28.227.101
```

To Delete an Authorized Manager Entry. This command uses the IP address of the authorized manager you want to delete:

```
HPswitch(config)# no ip authorized-managers 10.28.227.101
```

Web: Configuring IP Authorized Managers

In the web browser interface you can configure IP Authorized Managers as described below.

To Add, Modify, or Delete an IP Authorized Manager address:

1. Click on the **Security** tab.
2. Click on [Authorized Addresses](#).
3. Enter the appropriate parameter settings for the operation you want.
4. Click on [Add](#), [Replace](#), or [Delete](#) to implement the configuration change.

For web-based help on how to use the web browser interface screen, click on the  button provided on the web browser screen.

Building IP Masks

The IP Mask parameter controls how the switch uses an Authorized Manager IP value to recognize the IP addresses of authorized manager stations on your network.

Configuring One Station Per Authorized Manager IP Entry

This is the easiest way to apply a mask. If you have ten or fewer management and/or operator stations, you can configure them quickly by simply adding the address of each to the Authorized Manager IP list with **255.255.255.255** for the corresponding mask. For example, as shown in figure 7-3 on page 7-6, if you configure an IP address of **10.28.227.125** with an IP mask of **255.255.255.255**, only a station having an IP address of **10.28.227.125** has management access to the switch.

Figure 7-4. Analysis of IP Mask for Single-Station Entries

	1st Octet	2nd Octet	3rd Octet	4th Octet	Manager-Level or Operator-Level Device Access
IP Mask	255	255	255	255	The "255" in each octet of the mask specifies that only the exact value in that octet of the corresponding IP address is allowed. This mask allows management access only to a station having an IP address of 10.33.248.5.
Authorized Manager IP	10	28	227	125	

Configuring Multiple Stations Per Authorized Manager IP Entry

The mask determines whether the IP address of a station on the network meets the criteria you specify. That is, for a given Authorized Manager entry, the switch applies the IP mask to the IP address you specify to determine a range of authorized IP addresses for management access. As described above, that range can be as small as one IP address (if **255** is set for all octets in the mask), or can include multiple IP addresses (if one or more octets in the mask are set to less than **255**).

If a bit in an octet of the mask is “on” (set to 1), then the corresponding bit in the IP address of a potentially authorized station must match the same bit in the IP address you entered in the Authorized Manager IP list. Conversely, if a bit in an octet of the mask is “off” (set to 0), then the corresponding bit in the IP address of a potentially authorized station on the network does not have to match its counterpart in the IP address you entered in the Authorized Manager IP list. Thus, in the example shown above, a “255” in an IP Mask octet (*all* bits in the octet are “on”) means only one value is allowed for that octet—the value you specify in the corresponding octet of the Authorized Manager IP list. A “0” (all bits in the octet are “off”) means that any value from 0 to 255 is allowed in the corresponding octet in the IP address of an authorized station. You can also specify a series of values that are a subset of the 0-255 range by using a value that is greater than 0, but less than 255.

Figure 7-5. Analysis of IP Mask for Multiple-Station Entries

	1st Octet	2nd Octet	3rd Octet	4th Octet	Manager-Level or Operator-Level Device Access
IP Mask	255	255	255	0	The "255" in the first three octets of the mask specify that only the exact value in the octet of the corresponding IP address is allowed. However, the zero (0) in the 4th octet of the mask allows any value between 0 and 255 in that octet of the corresponding IP address. This mask allows switch access to any device having an IP address of 10.28.227.xxx, where xxx is any value from 0 to 255.
Authorized Manager IP	10	28	227	125	
IP Mask	255	255	255	249	In this example (figure 7-6, below), the IP mask allows a group of up to 4 management stations to access the switch. This is useful if the only devices in the IP address group allowed by the mask are management stations. The "249" in the 4th octet means that bits 0 and 3 - 7 of the 4th octet are fixed. Conversely, bits 1 and 2 of the 4th octet are variable. Any value that matches the authorized IP address settings for the fixed bits is allowed for the purposes of IP management station access to the switch. Thus, any management station having an IP address of 10.28.227. <u>121</u> , <u>123</u> , <u>125</u> , or <u>127</u> can access the switch.
Authorized IP Address	10	28	227	125	

4th Octet of IP Mask:		249							
4th Octet of Authorized IP Address:		5							
Bit Numbers	Bit 7	Bit 6	Bit 5	Bit 4	Bit 3	Bit 2	Bit 1	Bit 0	
Bit Values	128	64	32	16	8	4	2	1	
4th Octet of IP Mask (249)									Bits 1 and 2 in the mask are "off", and bits 0 and 3 - 7 are "on", creating a value of 249 in the 4th octet.
4th Octet of IP Authorized Address (125)									Where a mask bit is "on", the corresponding bit setting in the address of a potentially authorized station must match the IP Authorized Address setting for that same bit. Where a mask bit is "off" the corresponding bit setting in the address can be either "on" or "off". In this example, in order for a station to be authorized to access the switch:
									<ul style="list-style-type: none"> • The first three octets of the station's IP address must match the Authorized IP Address. • Bit 0 and Bits 3 through 6 of the 4th octet in the station's address must be "on" (value = 1). • Bit 7 of the 4th octet in the station's address must be "off" (value = 0). • Bits 1 and 2 can be either "on" or "off".
									This means that stations with the IP address 13.28.227.X (where X is 121, 123, 125, or 127) are authorized.

Figure 7-6. Example of How the Bitmap in the IP Mask Defines Authorized Manager Addresses

Additional Examples for Authorizing Multiple Stations

	Entries for Authorized Manager List				Results
IP Mask	255	255	0	255	This combination specifies an authorized IP address of 10.33.xxx.1. It could be applied, for example, to a subnetted network where each subnet is defined by the third octet and includes a management station defined by the value of "1" in the fourth octet of the station's IP address.
Authorized Manager IP	10	33	248	1	
IP Mask	255	238	255	250	Allows 230, 231, 246, and 247 in the 2nd octet, and 194, 195, 198, 199 in the 4th octet.
Authorized Manager IP	10	247	100	195	

Operating Notes

- **Network Security Precautions:** You can enhance your network's security by keeping physical access to the switch restricted to authorized personnel, using the password features built into the switch, and preventing unauthorized access to data on your management stations.
- **Modem and Direct Console Access:** Configuring authorized IP managers does not protect against access to the switch through a modem or direct Console (RS-232) port connection.
- **Duplicate IP Addresses:** If the IP address configured in an authorized management station is also configured in another station, the other station can gain management access to the switch even though a duplicate IP address condition exists.
- **Web Proxy Servers:** If you use the web browser interface to access the switch from an authorized IP manager station, it is recommended that you avoid the use of a web proxy server in the path between the station and the switch. This is because switch access through a web proxy server requires that you first add the web proxy server to the Authorized Manager IP list. *This reduces security by opening switch access to anyone who uses the web proxy server.* The following two options outline how to eliminate a web proxy server from the path between a station and the switch:

- Even if you need proxy server access enabled in order to use other applications, you can still eliminate proxy service for web access to the switch. To do so, add the IP address or DNS name of the switch to the non-proxy, or “Exceptions” list in the web browser interface you are using on the authorized station.
- If you don’t need proxy server access at all on the authorized station, then just disable the proxy server feature in the station’s web browser interface.

Index

Numerics

3DES ... 4-3

802.1x

See *port-based access control*. ... 5-1

A

aaa authentication ... 2-9

access levels, authorized IP managers ... 7-3

accounting

See *RADIUS*.

address

authorized for port security ... 6-3

authentication

See *TACACS*.

authorized addresses

for IP management security ... 7-4

for port security ... 6-3

authorized IP managers

access levels ... 7-3

building IP masks ... 7-9

configuring in browser interface ... 7-7, 7-8

configuring in console ... 7-5

definitions of single and multiple ... 7-4

effect of duplicate IP addresses ... 7-12

IP mask for multiple stations ... 7-10

IP mask for single station ... 7-9

IP mask operation ... 7-4

operating notes ... 7-12

overview ... 7-1

troubleshooting ... 7-12

C

Clear button

to delete password protection ... 1-5

configuration

port security ... 6-5

RADIUS

See *RADIUS*.

SSH

See *SSH*.

connection inactivity time ... 1-3

console, for configuring

authorized IP managers ... 7-5

D

DES ... 4-3

duplicate IP address

effect on authorized IP managers ... 7-12

E

event log

intrusion alerts ... 6-21

I

inconsistent value, message ... 6-12

intrusion alarms

entries dropped from log ... 6-23

event log ... 6-21

prior to ... 6-23

Intrusion Log

prior to ... 6-19, 6-20

IP

authorized IP managers ... 7-1

reserved port numbers ... 4-17

IP masks

building ... 7-9

for multiple authorized manager stations ... 7-10

for single authorized manager station ... 7-9

operation ... 7-4

L

LACP

802.1x, not allowed ... 5-28

M

manager password ... 1-2, 1-4

manager password recommended ... 2-8

MD5

See *RADIUS*.

message

inconsistent value ... 6-12

O

OpenSSH ... 4-3

operating notes

authorized IP managers ... 7-12

port security ... 6-22

operator password ... 1-2, 1-4

P

password

browser/console access ... 1-3

case-sensitive ... 1-4

caution ... 1-3

delete ... 1-4

deleting with the Clear button ... 1-5

if you lose the password ... 1-5

incorrect ... 1-3

length ... 1-4

operator only, caution ... 1-3

pair ... 1-2

setting ... 1-4

password pair ... 1-2

password security ... 4-18

port

security configuration ... 6-2

port security

authorized address definition ... 6-3

basic operation ... 6-2

configuring ... 6-5

configuring in browser interface ... 6-15, 6-22

event log ... 6-21

notice of security violations ... 6-15

operating notes ... 6-22

overview ... 6-2

prior to ... 6-23

proxy web server ... 6-22

port-based access control

authenticate switch ... 5-3

authenticate users ... 5-3

authenticator operation ... 5-4, 5-6

authenticator, show commands ... 5-21

block traffic ... 5-2

blocking non-802.1x device ... 5-16

CHAP ... 5-2

chap-radius ... 5-13

configuration commands ... 5-10

configuration overview ... 5-9

configuration, displaying ... 5-21

configuring method ... 5-13

counters ... 5-21

EAP ... 5-2

EAPOL ... 5-6

eap-radius ... 5-13

enabling on ports ... 5-11

enabling on switch ... 5-16

features ... 5-2

general setup ... 5-8

GVRP ... 5-27

LACP not allowed ... 5-28

local ... 5-13

local username and password ... 5-2

MD5 ... 5-6

messages ... 5-28

operation ... 5-4

overview ... 5-2

port-security, with 802.1x ... 5-15

RADIUS ... 5-2

RADIUS host IP address ... 5-14

rules of operation ... 5-7

show commands ... 5-21

show commands, supplicant ... 5-23

statistics ... 5-21

supplicant operation ... 5-6

supplicant operation, switch-port ... 5-5

supplicant state ... 5-23

supplicant statistics, note ... 5-24

supplicant, configuring ... 5-17

supplicant, configuring switch port ... 5-19

supplicant, enabling ... 5-18

switch username and password ... 5-2

terminology ... 5-6

troubleshooting, gvrp ... 5-24

used with port-security ... 5-15

VLAN operation ... 5-24

prior to ... 6-19, 6-20, 6-23

Privacy Enhanced Mode (PEM)

See *SSH*.

proxy

web server ... 6-22

Q

quick start ... xvii

R

RADIUS

- accounting ... 3-2, 3-16
 - accounting, configuration outline ... 3-18
 - accounting, configure server access ... 3-19
 - accounting, configure types on switch ... 3-20
 - accounting, exec ... 3-17, 3-20
 - accounting, interim updating ... 3-22
 - accounting, network ... 3-20
 - accounting, operating rules ... 3-17
 - accounting, server failure ... 3-18
 - accounting, session-blocking ... 3-22
 - accounting, start-stop method ... 3-21
 - accounting, statistics terms ... 3-24
 - accounting, stop-only method ... 3-21
 - accounting, system ... 3-17, 3-20
 - authentication options ... 3-2
 - authentication, local ... 3-14, 3-15
 - bypass RADIUS server ... 3-9
 - commands, accounting ... 3-16
 - commands, switch ... 3-6
 - configuration outline ... 3-6
 - configure server access ... 3-10
 - configuring switch global parameters ... 3-12
 - general setup ... 3-5
 - local authentication ... 3-9
 - MD5 ... 3-4
 - messages ... 3-29
 - network accounting ... 3-16
 - operating rules, switch ... 3-4
 - security ... 3-9
 - security note ... 3-2
 - server access order ... 3-17
 - server access order, changing ... 3-27
 - servers, multiple ... 3-13
 - show accounting ... 3-26
 - show authentication ... 3-25
 - SNMP access security not supported ... 3-2
 - statistics, viewing ... 3-23
 - terminology ... 3-3
 - TLS ... 3-4
 - web-browser access controls ... 3-15
 - web-browser security not supported ... 3-2, 3-15
- RADIUS accounting
See *RADIUS*.
- reserved port numbers ... 4-17

S

- security
 - authorized IP managers ... 7-1
 - per port ... 6-1
 - security violations
 - notices of ... 6-15
 - security, password
 - See *SSH*.
 - Series 4100GL, defined ... x
 - setting a password ... 1-4
 - setup screen ... xvii
- ### SSH
- authenticating switch to client ... 4-3
 - authentication, client public key ... 4-2
 - authentication, user password ... 4-2
 - caution, restricting access ... 4-19
 - caution, security ... 4-17
 - CLI commands ... 4-9
 - client behavior ... 4-15
 - client public-key authentication ... 4-18, 4-21
 - client public-key, clearing ... 4-25
 - client public-key, creating file ... 4-23
 - client public-key, displaying ... 4-24
 - configuring authentication ... 4-18
 - crypto key ... 4-11
 - disabling ... 4-11
 - enable ... 4-16
 - enabling ... 4-15
 - erase host key pair ... 4-11
 - generate host key pair ... 4-11
 - generating key pairs ... 4-10
 - host key pair ... 4-11
 - key, babble ... 4-11
 - key, fingerprint ... 4-11
 - keys, zeroizing ... 4-11
 - key-size ... 4-17
 - known-host file ... 4-13, 4-14
 - man-in-the-middle spoofing ... 4-12, 4-16
 - messages, operating ... 4-26
 - OpenSSH ... 4-3
 - operating rules ... 4-8
 - outbound SSH not secure ... 4-8
 - password security ... 4-18
 - password-only authentication ... 4-18
 - passwords, assigning ... 4-9
 - PEM ... 4-2, 4-4, 4-8, 4-14
 - prerequisites ... 4-5
 - public key ... 4-5, 4-13

- public key, displaying ... 4-14
- reserved IP port numbers ... 4-17
- security ... 4-12, 4-17
- SSHv1 ... 4-2, 4-3
- SSHv1 compatibility ... 4-12
- SSHv2 ... 4-2
- steps for configuring ... 4-6
- supported encryption methods ... 4-3
- switch key to client ... 4-12
- terminology ... 4-4
- unauthorized access ... 4-19, 4-26
- version ... 4-2
- zeroize ... 4-11
- zeroizing a key ... 4-11

T

TACACS

- aaa parameters ... 2-12
- authentication ... 2-4
- authentication process ... 2-20
- authentication, local ... 2-22
- authorized IP managers, effect ... 2-25
- configuration, authentication ... 2-11
- configuration, encryption key ... 2-19
- configuration, server access ... 2-15
- configuration, timeout ... 2-20
- configuration, viewing ... 2-10
- encryption key ... 2-7, 2-15, 2-16, 2-19
- encryption key, general operation ... 2-23
- encryption key, global ... 2-20
- general operation ... 2-2
- IP address, server ... 2-15
- local manager password requirement ... 2-26
- messages ... 2-25
- NAS ... 2-4
- overview ... x
- precautions ... 2-6
- preparing to configure ... 2-9
- preventing switch lockout ... 2-15
- privilege level code ... 2-7
- server access ... 2-15
- server priority ... 2-18
- setup, general ... 2-6
- show authentication ... 2-9
- supported features ... 2-3
- system requirements ... 2-5
- TACACS+ server ... 2-4

- testing ... 2-6
- timeout ... 2-15
- troubleshooting ... 2-6
- unauthorized access, preventing ... 2-8
- web access, controlling ... 2-24
- web access, no effect on ... 2-6
- tacacs-server ... 2-9
- Telnet ... 2-15
- test ... 2-15
- TLS
 - See *RADIUS*. ... 3-4
- troubleshoot ... 2-15
- troubleshooting
 - authorized IP managers ... 7-12

U

- user name
 - cleared ... 1-5

V

- value, inconsistent ... 6-12
- VLAN
 - 802.1x ... 5-24
 - 802.1x, ID changes ... 5-27

W

- warranty ... ii
- web browser interface, for configuring port security ... 6-22
 - authorized IP managers ... 7-7, 7-8
 - port security ... 6-15
- web server, proxy ... 6-22





i n v e n t

Technical information in this document
is subject to change without notice.

©Copyright Hewlett-Packard Company 2000, 2002.
All right reserved.

Reproduction, adaptation, or translation
without prior written permission is prohibited
except as allowed under the copyright laws.

Produced in Singapore
April 2002

Manual Part Number
5990-3032