

quick start guide



hp procurve routing switches
9304m, 9308m, and 9315m
(software release
7.5.X or greater)

www.hp.com/go/hpprocurve

Quick Start Guide

for the HP ProCurve Routing Switches

9304M, 9308M, and 9315M

(Software Release 7.5.X or Greater)

Copyright 2000 – 2002

Hewlett-Packard Company

All rights reserved. Reproduction, adaptation or translation without prior written permission is prohibited, except as allowed under the copyright laws.

Publication number

5990-3009

June 2002

Applicable Products

HP J4138A, HP J4139A, HP J4874A

Trademark Credits

Microsoft®, Windows®, Microsoft Windows NT® and Internet Explorer® are U.S. trademarks of Microsoft Corporation. Netscape® Navigator is a U.S. trademark of Netscape Communications Corporation. Cisco® is a trademark of Cisco Systems Inc.

Disclaimer

The information contained in this document is subject to change without notice.

HEWLETT-PACKARD COMPANY MAKES NO WARRANTY OF ANY KIND WITH REGARD TO THIS MATERIAL, INCLUDING BUT NOT LIMITED TO, THE IMPLIED WARRANTIES OF MERCHANTABILITY AND FITNESS FOR A PARTICULAR PURPOSE.

Hewlett-Packard shall not be liable for errors contained herein or for incidental or consequential damages in connection with the furnishing, performance or use of this material.

Hewlett-Packard assumes no responsibility for the use or reliability of its software on equipment that is not furnished by Hewlett-Packard.

A copy of the specific warranty terms applicable to your HP product and replacement parts can be obtained from your HP Sales and Service Office or authorized dealer.

Warranty

See the Customer Support and Warranty booklet included with the product.

A copy of the specific warranty terms applicable to your Hewlett-Packard products and replacement parts can be obtained from your HP Sales and Service Office or authorized dealer.

Safety Considerations

Prior to the installation and use of this product, review all safety markings and instructions.



Instruction Manual Symbol.

If the product is marked with the above symbol, refer to the product manual to protect the product from damage.

WARNING Denotes a hazard that can cause injury.

CAUTION Denotes a hazard that can damage equipment or data.

Do not proceed beyond a **WARNING** or **CAUTION** notice until you have understood the hazard and have taken appropriate precautions.

Use of control, adjustments or performance procedures other than those specified herein may result in hazardous radiation exposure.

Grounding

This product provides a protective earthing terminal. There must be an uninterrupted safety earth ground from the main power source to the product's input wiring terminals, power cord or supplied power cord set. Whenever it is likely that the protection has been impaired, disconnect the power cord until the ground has been restored.

If your LAN covers an area served by more than one power distribution system, be sure their safety grounds are securely interconnected.

LAN cables may occasionally be subject to hazardous transient voltages (such as lightning or disturbances in the electrical utilities power grid). Handle exposed metal components of the network with caution.

For more safety information, see "Safety and EMC Regulatory Statements", beginning on page v.

Servicing

There are no user-serviceable parts inside the user-installable modules comprising the product. Any servicing, adjustment, maintenance or repair must be performed only by service-trained personnel.

Contents

SAFETY AND EMC REGULATORY STATEMENTS v

CHAPTER 1

GETTING STARTED..... 1-1

INTRODUCTION 1-1
AUDIENCE 1-1
NOMENCLATURE 1-1
TERMINOLOGY 1-2
ORGANIZATION OF PRODUCT DOCUMENTATION 1-2
SUPPORT AND WARRANTY INFORMATION 1-3

CHAPTER 2

INSTALLATION..... 2-1

UNPACKING A SYSTEM 2-1
 PACKAGE CONTENTS 2-1
 GENERAL REQUIREMENTS 2-1
INSTALLATION PROCEDURES 2-2
 SUMMARY 2-2
 INSTALLATION PRECAUTIONS 2-3
PREPARING THE INSTALLATION SITE 2-4
 CABLING INFRASTRUCTURE 2-4
 INSTALLATION LOCATION 2-4
INSTALLING (OR REMOVING) OPTIONAL MODULES 2-4
 INSTALLING MODULES 2-4
 REMOVING MODULES 2-5
INSTALLING AND REMOVING (OPTIONAL) MINI-GBICs 2-6
 SOFTWARE VERSION AND MANAGEMENT MODULE REQUIREMENT 2-6
 INSTALLING OR REMOVING A MINI-GBIC 2-7
 INSTALLATION NOTES 2-7
 SOFTWARE SUPPORT FOR MINI-GBIC PORTS 2-7
INSTALLING (OR REMOVING) REDUNDANT POWER SUPPLIES 2-8
 DETERMINING POWER SUPPLY STATUS 2-8
 INSTALLING POWER SUPPLIES 2-8
 REMOVING POWER SUPPLIES 2-9
VERIFYING PROPER OPERATION 2-11

ATTACHING A PC OR TERMINAL2-12

 ATTACHING A PC OR TERMINAL USING A SERIAL PORT2-12

 ATTACHING A PC OR TERMINAL USING A DIRECT LAN CONNECTION2-12

ASSIGNING A PERMANENT PASSWORD2-14

 HOW TO ASSIGN A PASSWORD2-15

ASSIGN A PERMANENT IP ADDRESS2-16

MOUNTING THE DEVICE2-17

 DESKTOP INSTALLATION2-17

 RACK MOUNT INSTALLATION – CHASSIS DEVICES2-17

CONNECTING POWER TO THE DEVICE2-18

CONNECTING NETWORK DEVICES2-19

 CONNECTORS2-19

 CONNECTING TO OTHER SWITCHES, ROUTING SWITCHES, AND ETHERNET HUBS2-21

 CONNECTING TO WORKSTATIONS, SERVERS OR ROUTERS2-22

 TROUBLESHOOTING NETWORK CONNECTIONS2-22

VERIFYING PROPER CONNECTIONS2-23

 PINGING AN IP ADDRESS2-23

 TRACING A ROUTE2-23

MANAGING THE DEVICE2-23

 LOGGING ON THROUGH THE CLI2-23

 LOGGING ON THROUGH THE WEB MANAGEMENT INTERFACE2-25

SWAPPING MODULES2-27

NEXT STEPS2-31

HARDWARE SPECIFICATIONS.....A-1

SYSTEM ARCHITECTURE A-4

PHYSICAL VIEW A-4

 SLOT AND PORT NUMBERS A-5

 AC POWER CONNECTOR A-5

 FANS A-5

 LEDs A-6

 PORTS A-6

 TEMPERATURE SENSOR A-7

 RESET BUTTON A-7

PHYSICAL DIMENSIONS A-8

OPERATING ENVIRONMENT A-8

STORAGE ENVIRONMENT A-8

ELECTROMAGNETIC EMISSIONS A-8

IMMUNITY A-8

SAFETY AGENCY APPROVALS A-8

LASER A-8

INDEX

Safety and EMC Regulatory Statements

Safety Information



Documentation reference symbol. If the product is marked with this symbol, refer to the product documentation to get more information about the product.

WARNING

A WARNING in the manual denotes a hazard that can cause injury or death.

CAUTION

A CAUTION in the manual denotes a hazard that can damage equipment.

Do not proceed beyond a WARNING or CAUTION notice until you have understood the hazardous conditions and have taken appropriate steps.

Grounding

These are safety class I products and have protective earthing terminals. There must be an uninterruptible safety earth ground from the main power source to the product's input wiring terminals, power cord, or supplied power cord set. Whenever it is likely that the protection has been impaired, disconnect the power cord until the ground has been restored.

For LAN cable grounding:

- If your LAN covers an area served by more than one power distribution system, be sure their safety grounds are securely interconnected.
- LAN cables may occasionally be subject to hazardous transient voltages (such as lightning or disturbances in the electrical utilities power grid). Handle exposed metal components of the network with caution.

Servicing

There are no user-serviceable parts inside these products. Any servicing, adjustment, maintenance, or repair must be performed only by service-trained personnel.

These products do not have a power switch; they are powered on when the power cord is plugged in.

Informations concernant la sécurité



Symbole de référence à la documentation. Si le produit est marqué de ce symbole, reportez-vous à la documentation du produit afin d'obtenir des informations plus détaillées.

WARNING

Dans la documentation, un WARNING indique un danger susceptible d'entraîner des dommages corporels ou la mort.

CAUTION

Un texte de mise en garde intitulé CAUTION indique un danger susceptible de causer des dommages à l'équipement.

Ne continuez pas au-delà d'une rubrique WARNING ou CAUTION avant d'avoir bien compris les conditions présentant un danger et pris les mesures appropriées.

Cet appareil est un produit de classe I et possède une borne de mise à la terre. La source d'alimentation principale doit être munie d'une prise de terre de sécurité installée aux bornes du câblage d'entrée, sur le cordon d'alimentation ou le cordon de raccordement fourni avec le produit. Lorsque cette protection semble avoir été endommagée, débrancher le cordon d'alimentation jusqu'à ce que la mise à la terre ait été réparée.

Mise à la terre du câble de réseau local:

- si votre réseau local s'étend sur une zone desservie par plus d'un système de distribution de puissance, assurez-vous que les prises de terre de sécurité soient convenablement interconnectées.
- Les câbles de réseaux locaux peuvent occasionnellement être soumis à des surtensions transitoires dangereuses (telles que la foudre ou des perturbations dans le réseau d'alimentation public). Manipulez les composants métalliques du réseau avec précautions.

Aucune pièce contenue à l'intérieur de ce produit ne peut être réparée par l'utilisateur. Tout dépannage, réglage, entretien ou réparation devra être confié exclusivement à un personnel qualifié.

Cet appareil ne comporte pas de commutateur principal ; la mise sous tension est effectuée par branchement du cordon d'alimentation.

Hinweise zur Sicherheit



Symbol für Dokumentationsverweis. Wenn das Produkt mit diesem Symbol markiert ist, schlagen Sie bitte in der Produktdokumentation nach, um mehr Informationen über das Produkt zu erhalten.

WARNING

Symbol für Dokumentationsverweis. Wenn das Produkt mit diesem Symbol markiert ist, schlagen Sie bitte in der Produktdokumentation nach, um mehr Informationen über das Produkt zu erhalten.

CAUTION

Symbol für Dokumentationsverweis. Wenn das Produkt mit diesem Symbol markiert ist, schlagen Sie bitte in der Produktdokumentation nach, um mehr Informationen über das Produkt zu erhalten.

Fahren Sie nach dem Hinweis WARNING oder CAUTION erst fort, nachdem Sie den Gefahrenzustand verstanden und die entsprechenden Maßnahmen ergriffen haben.

Dies ist ein Gerät der Sicherheitsklasse I und verfügt über einen schützenden Erdungsterminal. Der Betrieb des Geräts erfordert eine ununterbrochene Sicherheitserdung von der Hauptstromquelle zu den Geräteingabeterminals, den Netzkabeln oder dem mit Strom belieferten Netzkabelsatz voraus. Sobald Grund zur Annahme besteht, daß der Schutz beeinträchtigt worden ist, das Netzkabel aus der Wandsteckdose herausziehen, bis die Erdung wiederhergestellt ist.

Für LAN-Kabelerdung:

- Wenn Ihr LAN ein Gebiet umfaßt, das von mehr als einem Stromverteilungssystem beliefert wird, müssen Sie sich vergewissern, daß die Sicherheitserdungen fest untereinander verbunden sind.
- LAN-Kabel können gelegentlich gefährlichen Übergangsspannungen ausgesetzt werden (beispielsweise durch Blitz oder Störungen in dem Starkstromnetz des Elektrizitätswerks). Bei der Handhabung exponierter Metallbestandteile des Netzwerkes Vorsicht walten lassen.

Dieses Gerät enthält innen keine durch den Benutzer zu wartenden Teile. Wartungs-, Anpassungs-, Instandhaltungs- oder Reparaturarbeiten dürfen nur von geschultem Bedienungspersonal durchgeführt werden.

Dieses Gerät hat keinen Netzschalter; es wird beim Anschließen des Netzkabels eingeschaltet.

Considerazioni sulla sicurezza



Simbolo di riferimento alla documentazione. Se il prodotto è contrassegnato da questo simbolo, fare riferimento alla documentazione sul prodotto per ulteriori informazioni su di esso.

WARNING

La dicitura WARNINGdenota un pericolo che può causare lesioni o morte.

CAUTION

La dicituraCAUTION denota un pericolo che può danneggiare le attrezzature.

Non procedere oltre un avviso di WARNING o di CAUTIONprima di aver compreso le condizioni di rischio e aver provveduto alle misure del caso.

Questo prodotto è omologato nella classe di sicurezza I ed ha un terminale protettivo di collegamento a terra. Dev'essere installato un collegamento a terra di sicurezza, non interrompibile che vada dalla fonte d'alimentazione principale ai terminali d'entrata, al cavo d'alimentazione oppure al set cavo d'alimentazione fornito con il prodotto. Ogniqualvolta vi sia probabilità di danneggiamento della protezione, disinserite il cavo d'alimentazione fino a quando il collegaento a terra non sia stato ripristinato.

Per la messa a terra dei cavi LAN:

- se la vostra LAN copre un'area servita da più di un sistema di distribuzione elettrica, accertatevi che i collegamenti a terra di sicurezza siano ben collegati fra loro;
- i cavi LAN possono occasionalmente andare soggetti a pericolose tensioni transitorie (ad esempio, provocate da lampi o disturbi nella griglia d'alimentazione della società elettrica); siate cauti nel toccare parti esposte in metallo della rete.

Nessun componente di questo prodotto può essere riparato dall'utente. Qualsiasi lavoro di riparazione, messa a punto, manutenzione o assistenza va effettuato esclusivamente da personale specializzato.

Questo apparato non possiede un commutatore principale; si mette scotto tensione all'inserirsi il cavo d'alimentazione.

Consideraciones sobre seguridad



Símbolo de referencia a la documentación. Si el producto va marcado con este símbolo, consultar la documentación del producto a fin de obtener mayor información sobre el producto.

WARNING

Una WARNING en la documentación señala un riesgo que podría resultar en lesiones o la muerte.

CAUTION

Una CAUTION en la documentación señala un riesgo que podría resultar en averías al equipo.

No proseguir después de un símbolo de WARNING o CAUTION hasta no haber entendido las condiciones peligrosas y haber tomado las medidas apropiadas.

Este aparato se enmarca dentro de la clase I de seguridad y se encuentra protegido por una borna de puesta a tierra. Es preciso que exista una puesta a tierra continua desde la toma de alimentación eléctrica hasta las bornas de los cables de entrada del aparato, el cable de alimentación o el juego de cable de alimentación suministrado. Si existe la probabilidad de que la protección a tierra haya sufrido desperfectos, desenchufar el cable de alimentación hasta haberse subsanado el problema.

Puesta a tierra del cable de la red local (LAN):

- Si la LAN abarca un área cuyo suministro eléctrico proviene de más de una red de distribución de electricidad, cerciorarse de que las puestas a tierra estén conectadas entre sí de modo seguro.
- Es posible que los cables de la LAN se vean sometidos de vez en cuando a voltajes momentáneos que entrañen peligro (rayos o alteraciones en la red de energía eléctrica). Manejar con precaución los componentes de metal de la LAN que estén al descubierto.

Este aparato no contiene pieza alguna susceptible de reparación por parte del usuario. Todas las reparaciones, ajustes o servicio de mantenimiento debe realizarlos solamente el técnico.

Este producto no tiene interruptor de potencia; se activa cuando se enchufa el cable de alimentación.

Safety Information (Japan)

安全性の考慮

安全記号



マニュアル参照記号。製品にこの記号がついている場合はマニュアルを参照し、注意事項等をご確認ください。

WARNING マニュアル中の「WARNING」は人身事故の原因となる危険を示します。

CAUTION マニュアル中の「CAUTION」は装置破損の原因となる危険を示します。

「WARNING」や「CAUTION」の項は飛ばさないで必ずお読みください。危険性に関する記載事項をよく読み、正しい手順に従った上で次の事項に進んでください。

これは安全性クラス I の製品で保護用接地端子を備えています。主電源から製品の入力配線端子、電源コード、または添付の電源コード・セットまでの間、切れ目のない安全接地が存在することが必要です。もしこの保護回路が損なわれたことが推測されるときは、接地が修復されるまで電源コードを外しておいてください。

LAN ケーブルの接地に関して:

- もし貴社の LAN が複数の配電システムにより電力を受けている領域をカバーしている場合には、それらのシステムの安全接地が確実に相互に結合されていることを確認してください。
- LAN ケーブルは時として危険な過度電圧（例えば雷や、配電設備の電力網での障害）にさらされることがあります。露出した金属部分の取扱いには十分な注意をはらってください。

本製品の内部にはユーザーが修理できる部品はありません。サービス、調整、保守および修理はサービス訓練を受けた専門家におまかせください。

本製品には電源スイッチがありません。電源コードを接続したとき電源入となります。

Safety Information (China)

HP 网络产品使用安全手册

使用须知

欢迎使用惠普网络产品，为了您及仪器的安全，请注意如下事项

1. 仪器要和地线相接。要使用有正确接地插头的电源线，使用中国国家规定的220V电源。
2. 避免高湿度和灰尘多的地方，否则易引起仪器内部部件的损坏。
3. 避免接近高温，避免接近直接热源，如直射太阳光、暖气等其它发热体。
4. 不得有异物或液体落入机内，以免部件短路。
5. 不要将强磁体放置于仪器附近。

警告

为了防止火灾或触电事故，请不要将该机放置于淋雨或潮湿处。

安装

安装辅助管理模块请参看安装指南。

保修及技术支持

如果您按以上步骤正确使用但遇到了问题，或想了解其它产品性能，请按以下方式与我们联络。

如果是硬件故障：

1. 与售出单位或当地维修机构联系。
2. 惠普维修中心：
北京市海淀区知春路56号 中航科技大厦
邮政编码：100086
电话：010-62623888 转 6101

如果是软件问题：

1. 惠普技术支持中心热线电话：010-65053888 转 5858
2. 传真自动回复系统：010-65055280

Lasers

The Gigabit-SX, Gigabit-LX, and Gigabit LH-LC Modules are Class 1 Laser Products.

Laser Klasse 1

The modules comply with IEC 825-2: 1993

EMC Regulatory Statements

U.S.A.

FCC Class A

This equipment has been tested and found to comply with the limits for a Class A digital device, pursuant to Part 15 of the FCC Rules. These limits are designed to provide reasonable protection against interference when the equipment is operated in a commercial environment. This equipment generates, uses, and can radiate radio frequency energy and, if not installed and used in accordance with the instruction manual, may cause interference to radio communications. Operation of this equipment in a residential area may cause interference in which case the user will be required to correct the interference at his own expense.

Canada

This product complies with Class A Canadian EMC requirements.

Australia/New Zealand



This product complies with Australia/New Zealand EMC Class A requirements.

Japan

VCCI Class A

この装置は、情報処理装置等電波障害自主規制協議会（VCCI）の基準に基づくクラスA情報技術装置です。この装置を家庭環境で使用すると電波妨害を引き起こすことがあります。この場合には使用者が適切な対策を講ずるよう要求されることがあります。

Korea

사용자 안내문 : A 급기기

이기는 업무용으로 전자파 적합등록을 받은 기기 이오니, 판매자 또는 사용자는 이점을 주의하시기 바라며, 만약 잘못 구입하셨을 때에는 구입한 곳에서 비업무용으로 교환하시기 바랍니다.

Taiwan

警告使用者：這是甲類的資訊產品，在居住的環境中使用時，可能會造成射頻干擾，在這種情況下，使用者會被要求採取某些適當的對策。

Regulatory Model Identification Number

For regulatory identification purposes, the HP ProCurve Routing Switch 9315M has been assigned a Regulatory Model Number. The Regulatory Model Number for this routing switch is RSVLC-0203.

This regulatory number should not be confused with the marketing name (HP ProCurve Routing Switch 9315M), or product numbers (J4874A, J4875A).

Introduction

This guide describes how to install the following devices:

- HP ProCurve Routing Switch 9315M
- HP ProCurve Routing Switch 9308M
- HP ProCurve Routing Switch 9304M

For configuration and other information, refer to the Installation and Getting Started Guide and other guides provided on the Documentation CD-ROM for release 7.5.X or greater, shipped with your HP routing switch chassis or management module. (For the latest version of routing switch documentation, visit:

<http://www.hp.com/go/hpprocurve>

Click on **technical support**, then **manuals**.

Audience

This guide assumes that you have a working knowledge of network hardware installation.

Nomenclature

This guide uses the following typographical conventions:

- Italic* highlights the title of another publication and occasionally emphasizes a word or phrase.
- Bold** highlights a CLI command.
- Bold Italic*** highlights a term that is being defined.
- Underline highlights a link on the Web management interface.
- Capitals highlights field names and buttons that appear in the Web management interface.

NOTE: A note emphasizes an important fact or calls your attention to a dependency.

WARNING: A warning calls your attention to a possible hazard that can cause injury or death.

CAUTION: A caution calls your attention to a possible hazard that can damage equipment.

Terminology

The following table defines basic product terms used in this guide.

Table 1.1: Product Terms

Term	Definition
chassis or Chassis device	A Switch or Routing Switch that accepts optional modules or power supplies. The HP 9315M, HP 9304M, and HP 9308M Routing Switches are Chassis devices.
Routing Switch or router	A Layer 2 and Layer 3 device that switches and routes network traffic. The term <i>router</i> is sometimes used in this document in descriptions of a Routing Switch's Layer 3 routing protocol features.
Switch	A Layer 2 device that switches network traffic.
HP9300	An example Command Line Interface (CLI) prompt. Actual prompts show the product number for the device, such as HP9300.

Organization of Product Documentation

Read Me First

The "Read Me First" document includes software release information, a brief "Getting Started" section, an accessory parts list, troubleshooting tips, operating notes, and other information that is not included elsewhere in the product documentation.

NOTE: HP periodically updates *Read Me First*. The latest version is available at <http://www.hp.com/go/hpprocurve>. (Click on **Technical Support**, then **Manuals**.)

Main Product Coverage

The main product documentation for your Routing Switch includes:

- *HP ProCurve Quick Start Guide* – a printed guide you can use as an easy reference to the installation and product safety information needed for out-of-box setup, plus the general product safety and EMC regulatory statements of which you should be aware when installing and using a Routing Switch.
- *HP ProCurve Installation and Getting Started Guide* – an electronic (PDF) guide containing product safety and EMC regulatory statements as well as installation and basic configuration information. This guide is included on the CD shipped with your HP product, and is also available on the HP ProCurve website.
- *HP ProCurve Advanced Configuration and Management Guide* – contains advanced configuration information for routing protocols and Quality of Service (QoS). In addition, appendixes in this guide contain reference information for network monitoring, policies and filters, and software and hardware specifications. This manual is included in a PDF (Portable Document Format) file on the CD shipped with your HP product, and also on the HP ProCurve website.
- *HP ProCurve Command Line Interface Reference* – provides a dictionary of CLI commands and syntax. An electronic copy of this reference is included as a PDF (Portable Document Format) file on the CD shipped with your HP product, and is also available on the HP ProCurve website.
- *HP ProCurve Security Guide* – provides procedures for securing management access to HP devices and for protecting against Denial of Service (DoS) attacks. An electronic copy of this guide is included as a PDF (Portable Document Format) file on the CD shipped with your HP product, and is also available on the HP ProCurve website.

These documents also are available in PDF file format on HP's ProCurve website.

Product Documentation CD: A Tool for Finding Specific Information and/or Printing Selected Pages

This CD is shipped with your HP product and provides the following:

- A **README.txt** file (or **README.pdf** file) describing the CD contents and use, including easy instructions on how to search the book files for specific information
- A **contents.pdf** file to give you easy access to the documentation on the CD
- Separate PDF files of the individual chapters and appendixes in the *Installation and Getting Started Guide*, *Advanced Configuration and Management Guide*, and the *Security Guide*, enabling you to easily print individual chapters, appendixes, and selected pages
- Single PDF files for each of the books, enabling you to use the Adobe® Acrobat® Reader to easily search for detailed information
- Additional files. These may include such items as a copy of the device software (OS), additional Readme files, and release notes.

Release Notes

These documents describe features that became available between revisions of the main product documentation. New releases of such documents will be available on HP's ProCurve website. To register to receive email notice from HP when a new software release is available, go to

<http://www.hp.com/go/hpprocurve> and click on **Technical Support**, then **Software**, and click on **Subscriber's Choice web page**.

Support and Warranty Information

Refer to *Support is as Close as the World Wide Web*, which was shipped with your HP Routing Switch.

This chapter outlines the physical installation and network connection for the HP 9304M, HP 9308M, and HP 9315M Routing Switches.

Unpacking a System

Package Contents

For a list of included parts, please refer to the *Read Me First* document shipped with your HP device.

General Requirements

To manage a Routing Switch, you need the following items for serial connection to the device:

- A management station, such as a PC running a terminal emulation application.
- A straight-through EIA/TIA DB-9 serial cable (M/F), which is provided with your HP Routing Switch.

Use the serial connection to perform basic configuration tasks including assigning an IP address and network mask to the system. This information is required for managing the system using the Web management interface or using the CLI through Telnet.



WARNING

9304M Exceeds 40 lbs. (18.1 kg)
9308M Exceeds 55 lbs. (24.9 kg)



9315M Exceeds 80 lbs. (35 kg) without modules and power supplies installed. To avoid personal injury, reduce weight of chassis by removing all modules and power supplies from chassis prior to lifting or moving.

When handling, two or more people are required.

WARNING: Do not use the extraction handles on the power supply units to lift or carry the HP 9304M, HP 9308M, or HP 9315M Routing Switch. The power supply extraction handles are not intended to support the weight of the system and must never be used to lift or move the chassis.

Installation Procedures

Summary

Follow the steps listed below to install your Routing Switch. Details for each of the steps highlighted below are provided in the rest of this chapter.

1. **Preparing the installation site (page 2-4).** Ensure that the physical environment that will host the Routing Switch has the proper cabling and ventilation.
2. **Installing (or Removing) Optional Modules (page 2-4).** There are several optional modules designed for any of the module slots on the HP 9304M, HP 9308M, or HP 9315M Routing Switches. Depending on where you will install the Routing Switch, it may be easier to install the modules first. However, the modules are “hot swappable”, and can be installed or removed after the Routing Switch is mounted and powered-on.

NOTE: If you are installing a second Redundant Management module, see “Using Redundant Management Modules” on page 3-1 for complete installation, configuration, and management instructions for this module. The non-redundant management modules (M1; J4141A, J4144A, and J4146A) cannot be used in the HP 9315M chassis.

3. **(Optional) Installing (or Removing) Redundant Power Supplies (page 2-8).** The HP 9304M can hold one or two power supplies. The HP 9308M and HP 9315M can hold up to four power supplies. If you have a power supply to install, it may be easier to install it before mounting the Routing Switch, although the power supplies are “hot swappable”, and can be installed or removed after the Routing Switch is mounted and powered-on.

CAUTION: Remove the power cord from a power supply before you install it in or remove it from the Routing Switch. Otherwise, damage to the power supply or the Routing Switch could result. (The Routing Switch can be running while a power supply is being installed or removed, *but the power supply itself should not be connected to a power source.*)

4. **Verifying Proper Operation (page 2-11).** Verify that the system and module LEDs are registering the proper LED state after power-on of the system.
5. **Attaching a PC or Terminal (page 2-12).** A terminal or PC serial port connection is all that is required to support configuration on the Routing Switch.
6. **Assign a Permanent Password (page 2-14).** No default password is assigned to HP devices. For additional access security, assign a password.
7. **Assign Permanent IP Addresses (page 2-16).** Before attaching equipment to the device, assign an interface IP address to the sub-net on which it will be located. Initial IP address assignment is done using the Command Line Interface (CLI) with either a direct serial connection or using Telnet with a direct terminal-to-device LAN connection. The subsequent IP address assignments used with Routing Switches can be done via Telnet or the Web management interface.
8. **Mounting the Device (page 2-17).** HP Routing Switches support both desktop and rack-mount installation.
9. **Connecting Power to the Device (page 2-18).** Once the device is physically installed, plug the device into a nearby power source in keeping with regulatory requirements outlined in this manual.
10. **Connecting Network Devices (page 2-19).** Once the device is powered on and IP addresses are assigned, the device is ready to accept network equipment.

CAUTION: Use the CESD grounding tap (provided by HP) before connecting Category 5 or better UTP copper networking cables.

11. **Verifying Proper Connections (page 2-23).** Test IP connectivity to other devices by pinging them and tracing routes.

12. **Managing the device (page 2-23).** Continue configuring the device using the CLI or the Web management interface.
13. **Swapping Modules (page 2-27).** If you are removing a module and placing a module of another type in its slot, you need to reconfigure the chassis slot for the module.

Installation Precautions

Follow these precautions when installing an HP Routing Switch:

WARNING: The HP 9304M chassis exceeds 40 lbs. (18 kg), or 47.7 lbs.(21.6 kg) when fully populated with modules and power supplies. Also, the HP 9308M chassis exceeds 55 lbs. (24.9 kg) or 69.1 lbs. (31.3 kg) when fully populated with modules and power supplies. **TWO OR MORE PEOPLE ARE REQUIRED WHEN LIFTING, HANDLING, OR MOUNTING THESE ROUTING SWITCHES.**

WARNING: The HP 9315M chassis exceeds 80 lbs (35 kg.) without modules and power supplies installed. To avoid personal injury, reduce weight of chassis by removing all modules and power supplies from chassis prior to lifting or moving. **TWO OR MORE PEOPLE ARE REQUIRED WHEN LIFTING, HANDLING, OR MOUNTING THIS ROUTING SWITCH.**

WARNING: Do not lift the 15-slot chassis using the lifting handles unless the chassis is empty. **TO REDUCE WEIGHT, REMOVE THE POWER SUPPLIES AND INTERFACE MODULES BEFORE LIFTING THE CHASSIS.**

WARNING: Do not use the extraction handles on the power supply units to lift or carry the Routing Switch. The power supply extraction handles are not intended to support the weight of the system and must never be used to lift or move the chassis.

WARNING: The rack or cabinet housing the Routing Switch should be adequately secured to prevent it from becoming unstable and/or falling over.

WARNING: To increase rack stability, devices installed in a rack or cabinet should be mounted as low as possible, with the heaviest device at the bottom and progressively lighter devices installed above.

CAUTION:

- Make sure that the power source circuits are properly grounded, then use the power cord supplied with the device to connect it to the power source.

If the installation requires a different power cord than the one supplied with the device, be sure to use a power cord displaying the mark of the safety agency that defines the regulations for power cords in your country. The mark is your assurance that the power cord can be used safely with the device.
- Note that the AC outlets should be near the Routing Switch, and should be easily accessible in case the Routing Switch must be powered off.
- Ensure that the device does not overload the power circuits, wiring, and over-current protection. To determine the possibility of overloading the supply circuits, add together the ampere ratings of all devices installed on the same circuit as the Routing Switch. Compare this total with the rating limit for the circuit. The maximum ampere ratings are usually printed on the devices, near their AC power connectors.
- Do not install the device in an environment where the operating ambient temperature might exceed 40 degrees C (104 degrees F).
- Make sure the air flow around the front, sides, and back of the device is not restricted.
- To provide additional safety and proper airflow to the device, make sure that slot cover plates are installed on all chassis slots that do not have either a module or power supply installed.

- Before connecting Category 5 or better UTP copper networking cables to a chassis module on the HP 9304M, HP 9308M, or HP 9315M, use the CESD grounding tap (shipped with the HP 9304M and HP 9308M and with chassis modules designed for UTP copper networking cables). See the *Cable Grounding Instructions* included with the CESD grounding tap. If you did not receive a CESD grounding tap kit (HP part number 5064-9974) with the above HP products, you can request one without charge from your HP Customer Care Center (CCC). To contact the CCC for your area, see the support and warranty booklet (*Support is as Close as the World Wide Web!*) shipped with your HP product. CCCs are also listed in the *HP ProCurve Networking Service and Support Guide* available at <http://www.hp.com/go/hpprocurve>. (Click on **Technical Support**, then **Support Services**.)
-

Preparing the Installation Site

Cabling Infrastructure

Ensure that the proper cabling is installed in the site. See “Hardware Overview” on page 10-1 for a summary of supported cabling types and their specifications.

Installation Location

Before installing the device, plan its location and orientation relative to other devices and equipment. Allow at least three inches (3") of space at the front of the device for the twisted-pair, fiber-optic and power cabling. Also, a minimum of three inches (3") of space should be allowed between the sides and the back of the device and walls or other obstructions.

Installing (or Removing) Optional Modules

Installing Modules

To install a module in the chassis, do the following:

1. Put on an ESD wrist strap and attach the clip end to a metal surface (e.g. an equipment rack) to act as ground.

WARNING: To avoid risk of shock, do not attach the clip end to the air flow panel of the power supply.

2. Remove the blank face plate from the slot in which the module is to be installed. Place the blank face plate in a safe place for future use.
3. Remove the module from its packaging.
4. Insert the module into the chassis slot and glide the card along the card guide until the card ejectors on the front of the module touch the chassis.

CAUTION: To avoid hardware damage during installation, be careful to properly line up the edges of the module board with the guides built into the module slot on the chassis.

NOTE: Modules for the HP 9308M and HP 9315M slide in vertically with the module label (e.g. ProCurve 9300) and port number 1 at the top (Figure 2.4). Modules for the HP 9304M slide in horizontally with the module label (e.g. ProCurve 9300) and port number 1 on the left (Figure 2.5).

5. Push the ejectors toward the center of the module until they are flush with the front panel of the module. The module will be fully seated in the backplane.
 6. Tighten the two screws at either end of the module.
-

CAUTION: If one or more of the slots remains unused, make sure that a slot cover plate is still attached over each unused slot for safe operation and proper system cooling.

Use the CESD grounding tap (provided by HP) before connecting Category 5 or better UTP copper networking cables.

NOTE: If installing a module into a slot *previously occupied by a different type of module*, you must use the CLI to configure the new module (with the CLI command, **module** <slot-num> <module-type>) and then use the **write memory** command to save the configuration and the **reload** command to reset the Routing Switch. See “Swapping Modules” on page 2-27. If the slot has never contained a module or you are swapping in exactly the same type of module, you do not need to enter these commands.

Figure 2.1 Installing a Module

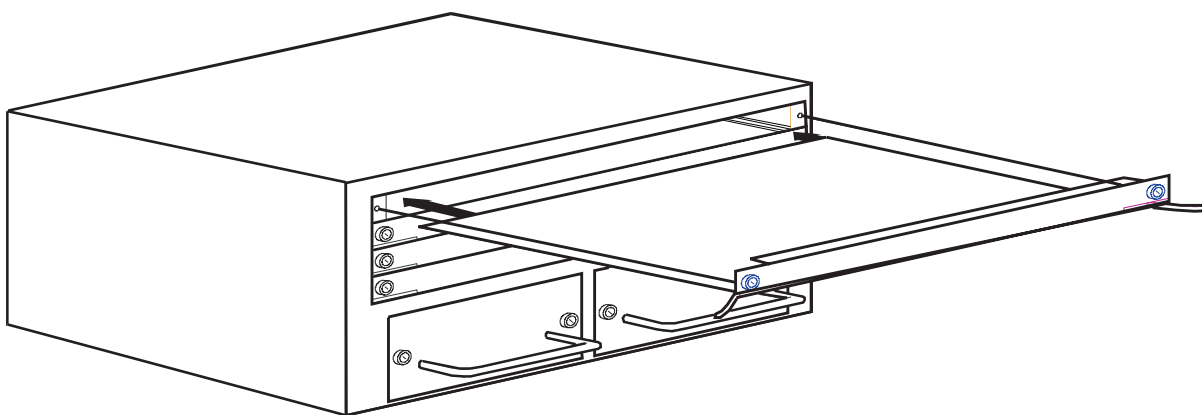

Removing Modules

To remove a module from the chassis, do the following:

1. Put on an ESD wrist strap and attach the clip end to a metal surface (e.g. an equipment rack) to act as ground.

WARNING: To avoid risk of shock, do not attach the clip end to the air flow panel of the power supply.

2. Loosen the two screws on the module.
3. Pull the card ejectors towards you, and away from the module front panel. The card will unseat from the backplane.
4. Pull the module out of the chassis and place in an anti-static bag for storage.
5. Cover the slot with the blank face plate that shipped with the chassis.

CAUTION: If you remove a module and do not replace it, cover the slot opening with one of the blank plates you received with the Routing Switch to provide additional safety and airflow for the system.

NOTE: Modules can be installed and removed when the unit is powered on (hot swap). There is no need to power the system down. You do not need to change the slot's configuration unless you plan to insert a different type of module. See “Swapping Modules” on page 2-27.

Installing and Removing (Optional) Mini-GBICs

This section provides installation information for the following HP ProCurve Mini-GBIC products:

- J4858A HP ProCurve Gigabit-SX Mini-GBIC: Supports multi-mode fiber; LC connector.
- J4859A HP ProCurve Gigabit-LX Mini-GBIC: Supports single-mode and multi-mode fiber; LC connector. (Multi-Mode LX supports a shorter distance than single-mode LX.)
- J4860A HP ProCurve LH-LC Mini-GBIC: Supports single-mode fiber; LC connector.

You can install any combination of the above mini-GBICs in the HP Procurve 9300 mini-GBIC modules listed in the following note.

NOTE: To use a Mini-GBIC, you must install it in either of the Mini-GBIC *modules* described below. This document assumes that you have already installed at least one of these modules in your HP Procurve Routing Switch 9304M, 9308M, or 9315M:

- J4856A HP Procurve 9300 Mini-GBIC Module
- J4857A HP Procurve 9300 Mini-GBIC Redundant Management Module

For information on installing a module in your routing switch, refer to either the printed *Quick Start Guide* or the electronic (PDF) *Installation and Configuration Guide* (on the *Documentation CD-ROM*) shipped with the routing switch chassis or management module. For a downloadable copy of the latest edition of these documents and other routing switch product documentation, visit <http://www.hp.com/go/procurve> and go to the **technical support** area.

Software Version and Management Module Requirement

The J4856A and J4857A HP Procurve Mini-GBIC modules listed above require one of the following software releases, depending on the type of management module you are using:

- 9304M or 9308M WITHOUT Redundant Management (M1 modules): Release 06.6.32 or greater (J4856A only).
- 9304M or 9308M WITH Redundant Management (MII or MIV modules): Release 07.1.19 or greater.

The latest software releases are available at <http://www.hp.com/go/procurve> (click on **software**).

If you have installed the J4856A HP ProCurve 9300 Mini-GBIC Module (which does not include management), then you can use either of the following management options:

- On the 9304M or 9308M (only), one of the following three management modules WITHOUT Redundant Management (with software release 06.6.32 or a later 6.X release installed):
 - J4141A HP Procurve 9300 10/100 Management Module (16-port; MI)*
 - J4144A HP Procurve 9300 Gigabit SX Management Module (8-port; MI)*
 - J4146A HP Procurve 9300 Gigabit 4LX/4SX Management Module (8-port; MI)*
- One or two Redundant Management modules (with software version 07.1.19 or later installed). These include any of the following:
 - J4845A HP Procurve 9300 GigLX Redundant Management Module (8-port; MII)*
 - J4846A HP Procurve 9300 GigSX Redundant Management Module (8-port; MII)*
 - J4847 HP Procurve 9300 Redundant Management Module (0-port, MII)*
 - J4857A HP Procurve 9300 Mini-GBIC Redundant Management Module (8-port; MIV)

(*Products no longer available from Hewlett-Packard.)

Installing or Removing a Mini-GBIC

To install a mini-GBIC:

1. Put on an electrostatic discharge (ESD) wrist strap and attach the clip end to a metal surface (such as an equipment rack) to act as ground.
2. If you have not already done so, install a J4856A HP Procurve 9300 Mini-GBIC Module or a J4857A HP Procurve 9300 Mini-GBIC Redundant Management Module in your routing switch. (Ensure that your routing switch is running a software version that supports the mini-GBIC module. Refer to “Software Version and Management Module Requirement” on page 2-6.)
3. Remove the mini-GBIC from its protective packaging.
4. Gently insert the mini-GBIC into the slot on the front panel of the module until the mini-GBIC clicks into place. The mini-GBICs are keyed to prevent incorrect insertion. A tab on the bottom of the mini-GBIC locks the mini-GBIC to the front panel of the module.
5. Remove the protective covering from the port connectors and store the covering for future use.
6. Insert the interface cable.

To remove a mini-GBIC:

1. Put on an ESD wrist strap and attach the clip end to a metal surface (such as an equipment rack) to act as ground.
2. Disconnect the interface cable from the mini-GBIC.
3. Insert the protective covering into the port connectors.
4. Do one of the following:
 - If the mini-GBIC has a bail, swing the bail out, and then gently pull on it to slide the mini-GBIC out of the module.
 - If the mini-GBIC has a movable collar, push the collar in towards the front panel of the routing switch and then gently pull on the mini-GBIC to slide it out of the module.
5. Pull the mini-GBIC out of the module.
6. Store the mini-GBIC in a safe, static-free place.

Installation Notes

1000Base-SX Ports

The 1000Base-SX mini-GBIC ports operate in full-duplex mode and support multi-mode fiber cabling through LC connectors. A 1000Base-SX mini-GBIC port must be connected to another 1000Base-SX port. Connection to a 1000Base-LX port or a 1000Base-LH port is not supported.

1000Base-LX Ports

The 1000Base-LX mini-GBIC ports operate in full-duplex mode and support both single-mode fiber (SMF) and multi-mode fiber (MMF) cabling through LC connectors. A 1000Base-LX mini-GBIC port must be connected to another 1000Base-LX port. Connection to a 1000Base-SX port or a 1000Base-LH port is not supported.

1000Base-LH Ports

The 1000Base-LH mini-GBIC ports operate in full-duplex mode and supports single-mode fiber (SMF) cabling through LC connectors. A 1000Base-LH mini-GBIC port must be connected to another 1000Base-LH port. Connection to a 1000Base-LX or 1000Base-SX mini-GBIC port is not supported.

Software Support for Mini-GBIC Ports

Hewlett-Packard offers and supports only mini-GBICs that include an HP label (product number J4858A, J4859A, or J4860A) for use with the J4856A HP ProCurve 9300 Mini-GBIC Module and the J4857A HP ProCurve 9300

Mini-GBIC Redundant Management Module. Use of other brands of mini-GBICs or the use of HP mini-GBICs in non-HP devices is not supported.

Installing (or Removing) Redundant Power Supplies

Determining Power Supply Status

If you are replacing a power supply that has failed and you are not sure which supply has failed, enter the following command at any CLI command prompt:

show chassis

This command displays status information for the fans and the power supplies. The power supplies are numbered in the display. The power supply numbers correspond to the following positions. These positions assume you are facing the front of the chassis, not the rear.

Table 2.1: Power Supply Positions in Chassis Devices

Product	Power Supply 1 Position	Power Supply 2 Position	Power Supply 3 Position	Power Supply 4 Position
HP 9304M	left side	right side	n/a	n/a
HP 9308M	bottom	second from bottom	second from top	top
HP 9315M	left side	second left	second right	right side

NOTE: The 9315M requires a minimum of two J4875A power supplies to power-up or reboot. With only two power supplies installed, if it becomes necessary to replace a failed power supply, you must first install and power-up the replacement power supply before you remove the failed power supply. Otherwise, the 9315M routing switch will cease to operate. Also, for true power supply redundancy(N+1) in both the 9315M and the 9308M, you must install all four power supplies in these units.

Installing Power Supplies

To install a power supply in the chassis, do the following:

CAUTION: Install the J4147A Power Supply only in the HP 9308M (J4138A) and HP 9304M (J4139A) Routing Switch chassis. Install the J4875A Power Supply only in the HP 9315M (J4874A) Routing Switch. *The J4147A and J4875A Power Supplies are not interchangeable.*

CAUTION: Power supplies are hot swappable but they should be disconnected from AC power before being installed or removed. That is, the Routing Switch can be running while a power supply is being installed or removed, but the power supply itself *should not be connected* to a power source. Otherwise, damage to the power supply or the Routing Switch could result.

1. Use a screwdriver to remove the blank power supply face plate. This will expose the empty power supply slot.
2. Remove the power supply from its packaging; or, if the power supply is connected to a power source, remove the power cable.
3. Holding the bar on the front panel of the power supply, insert the power supply into the empty power supply slot using the module guides provided on either side of the compartment.

CAUTION: Carefully follow the mechanical guides on each side of the power supply slot and make sure the power supply is properly inserted in the guides. Never insert the power supply upside down.

4. Continue to slide the power supply towards the back of the chassis until the two metal rods and the connector make contact with the back connector. Then push the power supply until the front panel of the power supply is flush with the rest of the chassis.
5. Use a screwdriver to tighten the two screws on either side of the power supply.
6. Connect the power cord to the front of the power supply.
7. Connect the power plug into an outlet.

Figure 2.2 Installing a Power Supply

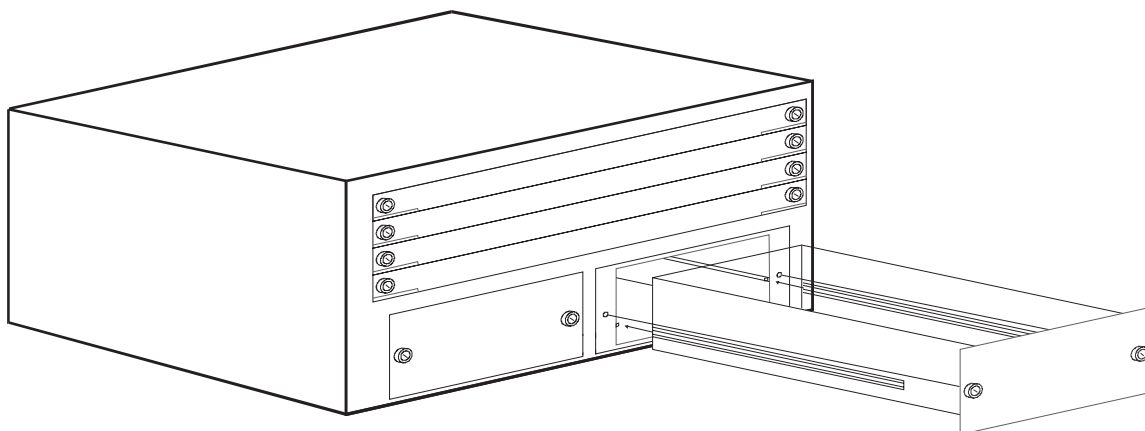

Removing Power Supplies

To remove a power supply module from the chassis, do the following:

CAUTION: Power supplies are hot swappable but they should be disconnected from AC power before being installed or removed. That is, the Routing Switch can be running while a power supply is being installed or removed, but the power supply itself *should not be connected* to a power source. Otherwise, damage to the power supply or the Routing Switch could result.

Install the J4147A Power Supply only in the HP 9308M (J4138A) and HP 9304M (J4139A) Routing Switch chassis. Install the J4875A Power Supply only in the HP 9315M (J4875A) Routing Switch. *The J4147A and J4875A Power Supplies are not interchangeable.*

1. Unplug the power supply AC power cord from the outlet.
2. Disconnect the power cord from the power supply.
3. Use a screwdriver to loosen the screws on either side of the power supply.
4. Holding the bar on the front panel of the power supply, pull outward, disconnecting the power supply from the backplane.
5. Continue to pull the power supply until it is removed from the chassis.
6. Place the power supply in an anti-static bag for storage.
7. Cover the power supply slot with the blank power supply cover that came with the device.
8. Use a screwdriver to tighten the screws.

Figure 2.3 Example of the front panel of an HP 9315M Routing Switch

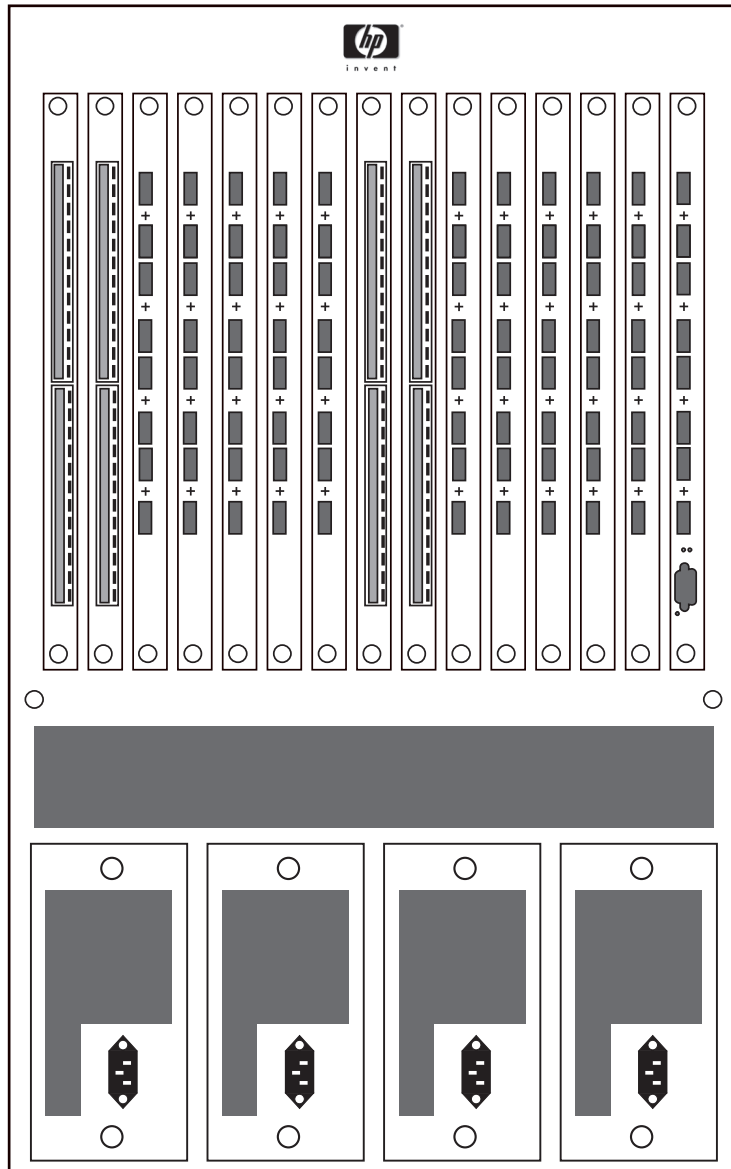

Figure 2.4 Example of the front panel of an HP 9308M Routing Switch

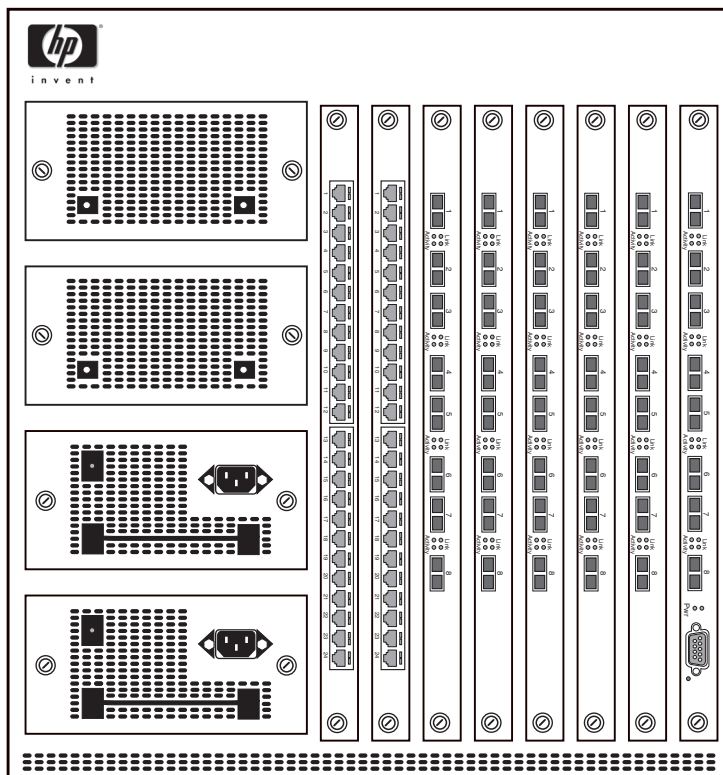
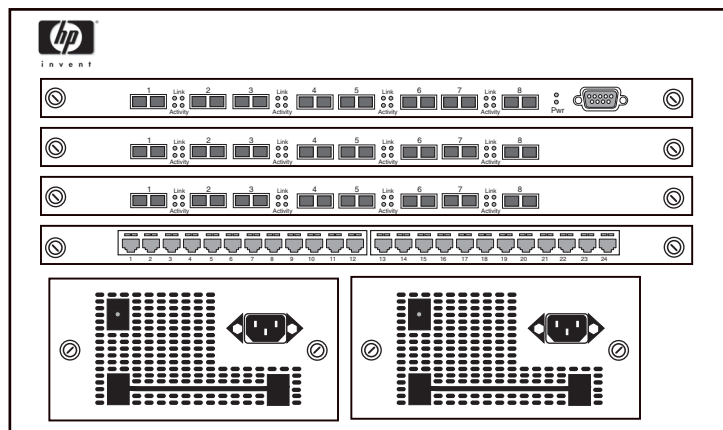

Figure 2.5 Example of the front panel of an HP 9304M Routing Switch



Verifying Proper Operation

After you have installed any modules or redundant power supplies, but before mounting the Routing Switch in its network location, you should first verify that it is working properly by plugging it into a power source and verifying that it passes its self test.

NOTE: If your device has more than one power supply installed, repeat this procedure for each power supply.

1. Connect the power cord supplied with the device to the power connector found on the power supply on the front of the device.

2. Insert the other end into a properly grounded electrical outlet.

NOTE: The devices do not have power switches. They are powered on when the power cord is connected to the device and to a power source.

If your installation requires a different power cord than that supplied with the device, be sure to obtain a power cord displaying the mark of the safety agency that defines the regulations for power cords in your country. The mark is your assurance that the power cord can be used safely with the device.

3. Verify proper operation by observing the LEDs. Make sure the LED on each power supply is a solid green. Also make sure that some of the port LEDs on each module momentarily light up. The LEDs indicate that the device is performing diagnostics. After the diagnostics are complete, the LEDs will be dark except for the ones that are attached by cables to other devices. If the links on these cables are good and the connected device is powered on, the link LEDs will light.

NOTE: If all of the LEDs on a module do not light up during the diagnostics, this does not indicate an error. Only some of the LEDs are lighted during the diagnostics.

For more details on specific LED conditions after system start-up, see “LEDs” on page 10-8.

Attaching a PC or Terminal

To assign an IP address, you must have access to the **Command Line Interface (CLI)**. The CLI is a text-based interface that can be accessed through a direct serial connection to the device and through Telnet connections. The CLI is described in detail in the *Command Line Interface Reference*.

You need to assign a permanent IP address using the CLI. You can access the CLI by attaching a serial cable to the Console port. After you assign an IP address, you can access the system through Telnet or the Web management interface.

Attaching a PC or Terminal Using a Serial Port

To attach a management station using the serial port:

1. Connect a PC or terminal to the serial port of the system via the (serial) console cable. The serial port is a male DB-9 connector. Generally, a PC port will require a cable with a female DB-9 connector. Terminal connections will vary, requiring either a DB-9 or DB-25 connector, male or female.

A console cable is provided with your Routing Switch. Cable pin-outs and signalling for the serial cable are shown in Figure 2.6 and Figure 2.7.

2. If you are using a PC for a terminal, run a terminal emulation program on the PC.
3. Set the terminal or PC terminal emulation program to the parameters shown below:
 - Baud: 9600 bps
 - Data bits: 8
 - Parity: None
 - Stop bits: 1
 - Flow control: None

Attaching a PC or Terminal Using a Direct LAN Connection

To attach a management station using a direct LAN connection:

NOTE: Use this procedure if you are unable to make the serial connection described above.

Important! Cable Grounding Instructions

HP provides a cable-grounding kit for use with HP 9304M/HP 9308M/HP 9315M chassis modules designed for UTP copper networking cable connections. Use this grounding kit to help prevent ESD damage to your Routing Switch components when connecting cables to the modules.

CAUTION: Before connecting Category 5 or better UTP copper networking cables to a chassis module on the HP 9304M, HP 9308M, or HP 9315M, use the CESD grounding tap (shipped with the HP 9304M/HP 9308M/HP 9315M and with chassis modules designed for UTP copper networking cables). See the *Cable Grounding Instructions* included with the CESD grounding tap. If you did not receive a CESD grounding tap kit (HP part number 5064-9974) with the above HP products, you can request one without charge from your HP Customer Care Center (CCC). To contact the CCC for your area, see the support and warranty booklet (*Support is as Close as the World Wide Web!*) shipped with your HP product. CCCs are also listed in the *HP ProCurve Networking Service and Support Guide* available at <http://www.hp.com/go/hpprocurve>. (Click on **Technical Support**, then **Support Services**.)

1. Directly connect the LAN port on a Telnet-capable terminal device such as a laptop or desktop PC to port 1 in slot 1.
2. Configure the terminal device with an IP address and subnet mask that assigns the terminal to the same subnet as the Routing Switch's IP address for port 1, slot 1.
3. From the DOS prompt, enter **telnet** <ip-addr> to access the Routing Switch CLI, where <ip-addr> is the IP address for the Routing Switch port.

When you establish the serial connection to the device, press Enter to display the CLI prompt for your Routing Switch. For example:

```
HP9304>
```

```
HP9308>
```

```
HP9315>
```

NOTE: For simplicity, CLI examples for the Routing Switches generally show the command prompt "HP9300". This command prompt represents either the HP 9304M, HP 9308M, or HP 9315M unless otherwise noted.

If you see one of these prompts, you are now connected to the system and can proceed to "Assigning a Permanent Password" on page 2-14.

You can customize the prompt by changing the system name. See "Entering System Administration Information" on page 4-3.

If you do not see one of these prompts:

1. Make sure the cable is securely connected to your PC and to the HP device.
2. Check the settings in your terminal emulation program. In addition to the session settings listed above, make sure the terminal emulation session is running on the same serial port you attached to the HP device.

The EIA/TIA 232 serial communication port serves as a connection point for management by a PC or SNMP workstation. HP Routing Switches come with a standard male DB-9 connector, shown in Figure 2.6.

Figure 2.6 Serial port pin and signalling details

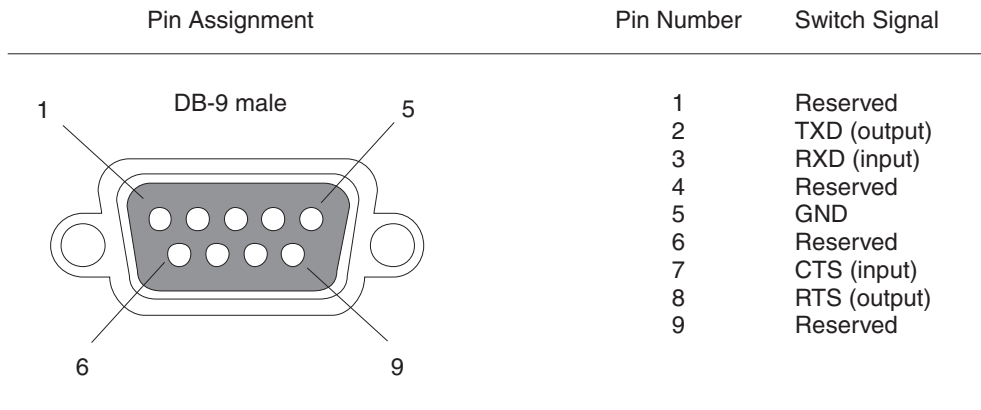

Most PC serial ports also require a cable with a female DB-9 connector. Terminal connections will vary, requiring either a DB-9 or DB-25 connector, male or female. Serial cable options between an HP Routing Switch and a PC terminal are shown in Figure 2.7.

NOTE: As indicated in Figure 2.6 and Figure 2.7, some of the wires should not be connected. If you do connect the wires that are labeled “Reserved”, you might get unexpected results with some terminals.

Figure 2.7 Serial port signal directions

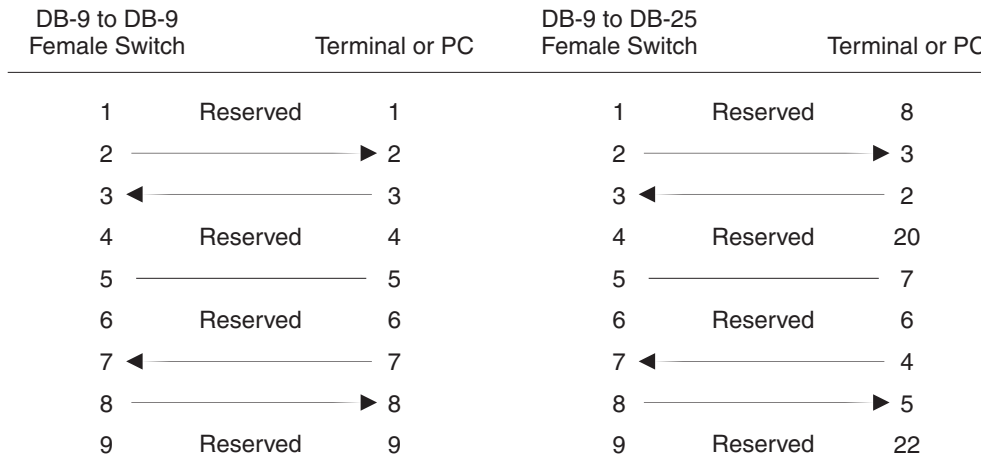

Assigning a Permanent Password

CLI access does not require a password by default. If you want to configure a password, you must use the CLI. A password cannot be assigned through the Web management interface.

The CLI contains the following access levels:

- **User EXEC level** – The level you enter when you first start a CLI session. At this level, you can view some system information but you cannot configure system or port parameters.
- **Privileged EXEC level** – This level is also called the Enable level and can be secured by a password. You can perform tasks such as manage files on the flash module, save the system configuration to flash, and clear caches at this level.
- **CONFIG level** – The configuration level. This level lets you configure the system’s IP address and configure

switching and routing features. To access the CONFIG mode, you must already be logged into the Privileged level of the EXEC mode.

By default, there are no CLI passwords. To secure CLI access, you must assign passwords.

NOTE: You must use the CLI to assign a password. You cannot assign a password using the Web management interface or an SNMP network management application.

You can set the following levels of Enable passwords:

- Super User – Allows complete read-and-write access to the system. This is generally for system administrators and is the only password level that allows you to configure passwords. *You must set a super user password before you can set other types of passwords.*
- Port Configuration – Allows read-and-write access for specific ports but not for global (system-wide) parameters.
- Read Only – Allows access to the Privileged EXEC mode and CONFIG mode but only with read access.

How To Assign a Password

When you first connect to the CLI, you are at the User EXEC level of the CLI. This is the first level of the CLI. The next level is the Privileged EXEC level. You need to get to the global CONFIG level of the CONFIG command structure to assign a permanent password.

To reach the global CONFIG level and assign passwords, use the following steps:

1. At the opening prompt, enter the following command to go from the User EXEC level to the Privileged EXEC level:

```
HP9300> enable
```

2. Access the configuration level of the CLI by entering the following command:

```
HP9300# configure terminal          Privileged EXEC Level
HP9300 (config)#                   Global CONFIG Level
```

3. To set the super-user password:

```
HP9300 (config)# enable super-user-password <string>
```

NOTE: You must set a super-user password before you can set other types of passwords.

4. To set the port-configuration and read-only passwords:

```
HP9300 (config)# enable read-only-password <string>
HP9300 (config)# enable port-config-password <string>
```

How to Recover From a Lost Password

Recovery from a lost password requires direct access to the serial port and a system reset of the device.

NOTE: You can perform this procedure only from the CLI.

To recover from a lost password:

1. Start a CLI session over the serial interface to the device.
2. Reboot the device.
3. While the system is booting, before the initial system prompt appears, enter **b** to enter the boot monitor mode.
4. Enter **no password** at the prompt. This command cannot be abbreviated. This command will cause the device to bypass the system password check.

5. Enter **boot system flash primary**.
6. After the console prompt reappears, assign a new password.

Assign a Permanent IP Address

Before attaching an HP Routing Switch to your network, you must assign an interface IP address to the sub-net on which the Routing Switch will be located. For subsequent addresses, you also can use the CLI through Telnet or use the Web management interface.

Using a serial connection is the recommended method for assigning the first IP address on a Routing Switch. (You also can use Telnet with a direct, terminal-to-device LAN connection if necessary—see “Attaching a PC or Terminal Using a Direct LAN Connection” on page 2-12.)

On the HP 9304M, HP 9308M, or HP 9315M, you can configure up to 24 IP interfaces on each port, virtual interface, and loopback interface. See “Displaying and Modifying System Parameter Default Settings” on page 4-40.

The following procedure shows how to add an IP address and mask to a Routing Switch port.

1. At the opening CLI prompt, enter **enable**.

```
HP9300> enable
```

2. If you are prompted for the password you created in “Assigning a Permanent Password” on page 2-14, enter the password.
3. Enter the following command at the Privileged EXEC level prompt (for example, HP9300#), then press Enter. This command erases the factory test configuration if still present:

```
HP9300# erase startup-config
```

CAUTION: Use this step only for new systems. If you enter this command on a system you have already configured, the command erases the configuration. If you accidentally do erase the configuration on a configured system, enter the **write memory** command to save the running configuration to the startup-config file.

4. Access the configuration level of the CLI by entering the following command:

```
HP9300# configure terminal          Privileged EXEC Level
HP9300(config)#                   Global CONFIG Level
```

5. Set the IP and mask addresses.

```
HP9300(config)# int e 1/5
HP9300(config-if-1/5)# ip address 192.22.3.44 255.255.255.0
```

NOTE: You can use the syntax, **ip address** <ip-addr> /<mask-bits> if you know the sub-net mask length. In the above example, you could enter **ip address 192.22.3.44/24**.

Syntax: enable [<password>]

Syntax: configure terminal

Syntax: [no] ip address <ip-addr> <ip-mask> [secondary]

or

Syntax: [no] ip address <ip-addr>/<mask-bits> [secondary]

Use the **secondary** parameter if you have already configured an IP address within the same sub-net on the interface.

Mounting the Device

The HP Routing Switches can be installed on a desktop or in a rack.

WARNING: The HP 9304M chassis exceeds 40 lbs. (18 kg), or 47.7 lbs.(21.6 kg) when fully populated with modules and power supplies. Also, the HP 9308M chassis exceeds 55 lbs. (24.9 kg) or 69.1 lbs. (31.3 kg) when fully populated with modules and power supplies. **TWO OR MORE PEOPLE ARE REQUIRED WHEN LIFTING, HANDLING, OR MOUNTING THESE ROUTING SWITCHES.**

WARNING: The HP 9315M chassis exceeds 80 lbs (35 kg.) without modules and power supplies installed. To avoid personal injury, reduce weight of chassis by removing all modules and power supplies from chassis prior to lifting or moving. **TWO OR MORE PEOPLE ARE REQUIRED WHEN LIFTING, HANDLING, OR MOUNTING THIS ROUTING SWITCH.**

WARNING: Do not lift the 15-slot chassis using the lifting handles unless the chassis is empty. **TO REDUCE WEIGHT, REMOVE THE POWER SUPPLIES AND INTERFACE MODULES BEFORE LIFTING THE CHASSIS.**

WARNING: Do not use the extraction handles on the power supply units to lift or carry the Routing Switch. The power supply extraction handles are not intended to support the weight of the system and must never be used to lift or move the chassis.

WARNING: Make sure the rack or cabinet housing the Routing Switch is adequately secured to prevent it from becoming unstable and/or falling over.

WARNING: To increase rack stability, mount the devices you install in a rack or cabinet as low as possible, with the heaviest device at the bottom and progressively lighter devices installed above.

Desktop Installation

1. Set the device on a flat desktop, table, or shelf. Use a sturdy surface in an uncluttered area. You may want to secure the networking cables and power cord to the table legs or other part of the surface structure to help prevent people from tripping over them.
2. Make sure that adequate ventilation is provided for the system—a minimum of three inches (3") clearance is recommended on all sides.

NOTE: Make sure the air flow is unrestricted around the front, sides, and back of the Routing Switch.

3. Proceed to “Connecting Power to the Device” on page 2-18.

Rack Mount Installation – Chassis Devices

NOTE: You need a #2 Phillips-head screwdriver for installation.

! WARNING

9304M Exceeds 40 lbs. (18.1 kg)
9308M Exceeds 55 lbs. (24.9 kg)

9315M Exceeds 80 lbs. (35 kg) without modules and power supplies installed. To avoid personal injury, reduce weight of chassis by removing all modules and power supplies from chassis prior to lifting or moving.

When handling, two or more people are required.



1. Remove the rack mount kit from the shipping carton. There will be two L-shaped mounting brackets and mounting screws.
2. Attach the mounting brackets to the sides of the Routing Switch as illustrated in Figure 2.8.
3. Attach the system in the rack as illustrated in Figure 2.8.
4. Proceed to “Connecting Power to the Device” on page 2-18.

Figure 2.8 Installing an HP 9304M Routing Switch in a rack mount

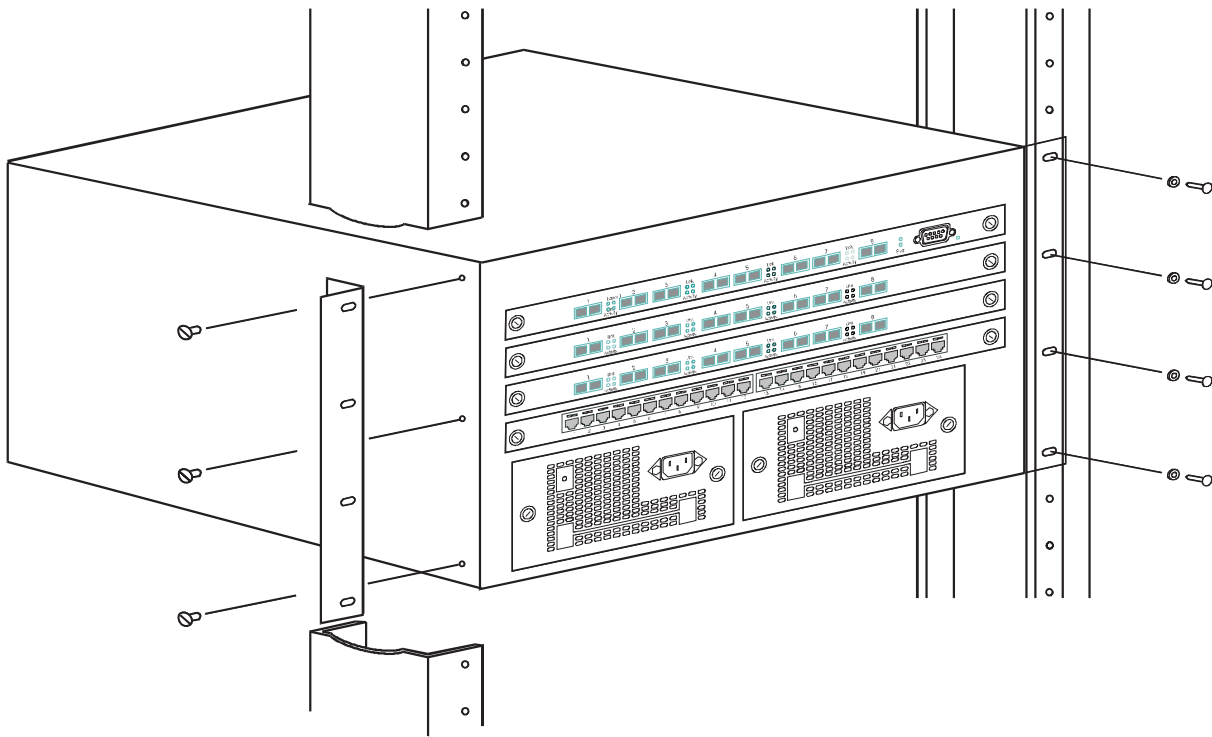

Connecting Power to the Device

With physical installation of the Routing Switch complete, it is now time to power up the system and connect the network devices.

CAUTION: There is no separate on/off power switch for the device. The device is powered on when the power cord is connected to a power supply and to a power source. To turn the system off, simply unplug the power cord(s).

CAUTION: The power sockets should be installed near the device and should be easily accessible.

CAUTION: If your installation requires a different power cord than the one supplied with the device, be sure to use a power cord displaying the mark of the safety agency that defines the regulations for power cords in your country. The mark is your assurance that the power cord can be used safely with the system.

NOTE: When you power on a Chassis device that requires multiple power supplies, make sure you apply power to all the supplies (or at least the minimum number of supplies required for your configuration) at the same time. Otherwise, the device either will not boot at all, or will boot and then repeatedly display a warning message stating that you need to add more power supplies.

1. Ensure that all modules and power supplies are properly inserted, and that no module slots or power supply slots are uncovered.
-

WARNING: Electrical shock hazard. Never allow any part of your body to be inside the chassis when the device is connected to a power source or to the network.

2. Remove the power cord from the shipping package.
 3. Attach the AC power cord to the AC connector on the front panel of the Chassis device. If more than one power supply is installed, attach a power cord for each power supply.
 4. Insert the power cord plug(s) into the appropriate outlet(s).
-

Connecting Network Devices

HP Routing Switches can support connections to other vendors' routers, switches, and hubs as well as to other HP Routing Switches and hubs.

Important! Cable Grounding Instructions

HP provides a cable-grounding kit for use with HP 9304M, HP 9308M, or HP 9315M chassis modules designed for UTP copper networking cable connections. Use this grounding kit to help prevent ESD damage to your Routing Switch components when connecting cables to the modules.

CAUTION: Before connecting Category 5 or better UTP copper networking cables to a chassis module on the HP 9304M or HP 9308M, use the CESD grounding tap (shipped with the HP 9304M, HP 9308M, or HP 9315M and with chassis modules designed for UTP copper networking cables). See the *Cable Grounding Instructions* included with the CESD grounding tap. If you did not receive a CESD grounding tap kit (HP part number 5064-9974) with the above HP products, you can request one without charge from your HP Customer Care Center (CCC). To contact the CCC for your area, see the support and warranty booklet (*Support is as Close as the World Wide Web!*) shipped with your HP product. CCCs are also listed in the *HP ProCurve Networking Service and Support Guide* available at <http://www.hp.com/go/hpprocurve>. (Click on **Technical Support**, then **Support Services**.)

Connectors

- 10/100BaseTX ports come with RJ45 jacks for standard unshielded twisted pair (UTP/Category 5) cable connections.
 - 100BaseFX ports come equipped with MT-RJ connectors.
 - 1000BaseSX ports come equipped with SC connectors.
-

- 1000BaseLX ports come equipped with SC connectors.
- 1000BaseT ports come equipped with RJ-45 connectors.

Figure 2.9 Pin assignment and signalling for 10/100BaseTX and 1000BaseT ports

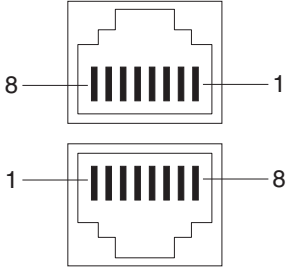
Pin Assignment	10BaseT		100BaseTX and 1000BaseT	
	Pin Number	MDI-X ports	Pin Number	MDI-X ports
	1	RD+	1	RD+
	2	RD-	2	RD-
	3	TD	3	TD
	4	Not used	4	CMT
	5	Not used	5	CMT
	6	TD-	6	TD-
	7	Not used	7	CMT
	8	Not used	8	CMT

Cable Length

- 1000BaseT: Cable length should not exceed 100 meters.
- 100BaseTX: Cable length should not exceed 100 meters.
- 100BaseFX: Cable length should not exceed 2 kilometers.
- 1000BaseSX: Cable length should not exceed 550 meters when operating with multi-mode cabling.
- 1000BaseLX:
 - Cable length of 2 – 440 meters is supported on 62.5 μm multi-mode fiber (MMF) cabling.
 - Cable length of 2 – 550 meters is supported on 50 μm multi-mode fiber (MMF) cabling.
 - Cable length of 2 – 5000 meters is supported on 9 μm single-mode fiber (SMF) cabling.
- 1000BaseLH: Up to 70000 meters is supported on 9 μm single-mode fiber (SMF) cabling.

NOTE: Where HP 1000BaseLH mini-GBICs are used at both ends of a link, a 5 dB loss is required between the transmit and receive mini-GBIC to avoid saturating the receiver. That is, the signal strength at the receiver should be no greater than -3 dB. If the signal strength exceeds this value, then attenuation is required on the link. If the receiving device is a non-supported (non-HP) mini-GBIC, its requirements may vary from the values in this note. In this case, refer to the documentation provided with the device.

Table 2.2: Cable length summary table

	Fiber Type	Core Diameter (microns)	Modal Bandwidth (MHz*km)	Minimum Range (meters)
1000BaseSX	MMF	62.5	160	2 – 200 ^a
	MMF	62.5	200	2 – 275 ^b
	MMF	50	400	2 – 500
	MMF	50	500	2 – 550 ^c
1000BaseLX	MMF	62.5	500	2 – 550
	MMF	50	400	2 – 550
	MMF	50	500	2 – 550
	SMF	9	n/a	2 – 5000
1000BaseLH	SMF	9		Up to 70000 (maximum supported)

a. The TIA 568 building wiring standard specifies 160/500 MHz*km MMF (Multi-mode Fiber).

b. The international ISO/IEC 11801 building wiring standard specifies 200/500 MHz*km MMF.

c. The ANSI Fibre Channel specification specifies 500/500 MHz*km 50 micron MMF and 500/500 MHz*km fiber has been proposed for addition to ISO/IEC 11801.

NOTE: Cable installation and network configuration will affect overall transmission capability. The numbers provided above represent the accepted recommendations of the various standards. For network-specific recommendations, consult your local HP reseller or system engineer.

Connecting to Other Switches, Routing Switches, and Ethernet Hubs

For connections to Ethernet hubs, a 10/100BaseTX or 1000BaseT switch, or another HP Routing Switch, a crossover cable is required (Figure 2.10 or Figure 2.11). If the hub is equipped with an uplink port, it will require a straight-through cable instead of a crossover cable.

Figure 2.10 UTP crossover cable for 10/100BaseTX

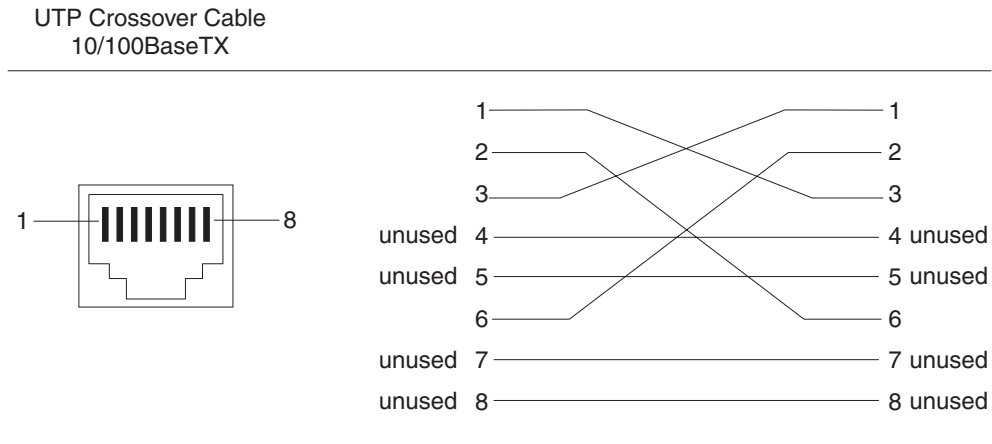
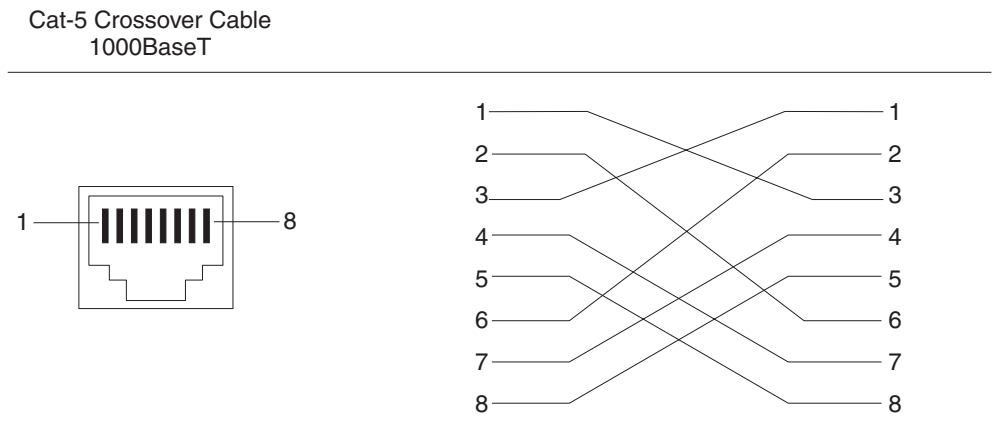

Figure 2.11 UTP crossover cable for 1000BaseT



NOTE: The 802.3ab standard calls for automatic negotiation of the connection between two 1000BaseT ports. Consequently, a crossover cable may not be required; a straight-through cable may work as well.

Connecting to Workstations, Servers or Routers

Straight-through UTP cabling is required for direct UTP attachment to workstations, servers, or routers via network interface cards (NICs).

Fiber cabling with SC connectors is required for direct attachment to Gigabit NICs or switches and routers.

Troubleshooting Network Connections

- For the indicated port, verify that both ends of the cabling, at the Routing Switch and the connected device, are snug.
- Verify the connected device and the Routing Switch are both powered on and operating correctly.
- Verify that you have used the correct cable type for the connection:
 - For twisted-pair connections to an end node, use straight-through cabling.
 - For fiber-optic connections, verify that the transmit port on the Routing Switch is connected to the receive

port on the connected device, and that the receive port on Routing Switch is connected to the transmit port on the connected device.

- Verify that the port has not been disabled through a configuration change. You can use the CLI or if you have configured an IP address on the Routing Switch, you can use the Web management interface.
- If the other procedures don't resolve the problem, try using a different port or a different cable.

Verifying Proper Connections

After you install the network cables, you can test network connectivity to other devices by pinging those devices. You also can perform trace routes.

Pinging an IP Address

To verify that an HP device can reach another device through the network, enter a command such as the following at any level of the CLI on the HP device:

```
HP9300> ping 192.33.4.7
```

Syntax: ping <ip addr> | <hostname> [source <ip addr>] [count <num>] [timeout <msec>] [ttl <num>] [size <byte>] [quiet] [numeric] [no-fragment] [verify] [data <1-to-4 byte hex>] [brief]

See the *Command Line Interface Reference* for information about its parameters.

NOTE: If you address the ping to the IP broadcast address, the device lists the first four responses to the ping.

Tracing a Route

To determine the path through which an HP device can reach another device, enter a command such as the following at any level of the CLI on the HP device:

```
HP9300> traceroute 192.33.4.7
```

Syntax: traceroute <host-ip-addr> [maxttl <value>] [minttl <value>] [numeric] [timeout <value>] [source-ip <ip addr>]

The CLI displays trace route information for each hop as soon as the information is received. Traceroute requests display all responses to a given TTL. In addition, if there are multiple equal-cost routes to the destination, the HP device displays up to three responses by default. See the *Command Line Interface Reference* for information about the command syntax.

Managing the Device

You can manage an HP device using the following applications:

- Command Line Interface (CLI) – a text-based interface accessible through a direct serial connection or a Telnet session.
- Web management interface – A GUI-based management interface accessible through an HTTP (web browser) connection.
- SNMP network management application – An application such as HP TopTools for Switches & Hubs or HP OpenView.

Logging on Through the CLI

Once an IP address is assigned to an interface on the HP Routing Switch, you can access the CLI either through the direct serial connection to the device or through a local or remote Telnet session.

You can initiate a local Telnet or SNMP connection by attaching a straight-through RJ-45 cable to a port and specifying the assigned management station IP address.

The commands in the CLI are organized into the following levels:

- User EXEC level – Lets you display information and perform basic tasks such as pings and traceroutes.
- Privileged EXEC level – Lets you use the same commands as those at the User EXEC level plus configuration commands that do not require saving the changes to the system-config file.
- CONFIG level – Lets you make configuration changes to the device. To save the changes across reboots, you need to save them to the system-config file. The CONFIG level contains sub-levels for individual ports, for VLANs, for routing protocols, and other configuration areas.

NOTE: By default, any user who can open a serial or Telnet connection to the HP device can access all these CLI levels. To secure access, you can configure Enable passwords or local user accounts, and you can configure the device to use a RADIUS or TACACS/TACACS+ server for authentication. See the *Security Guide*.

On-Line Help

To display a list of available commands or command options, enter “?” or press Tab. If you have not entered part of a command at the command prompt, all the commands supported at the current CLI level are listed. If you enter part of a command, then enter “?” or press Tab, the CLI lists the options you can enter at this point in the command string.

If you enter an invalid command followed by ?, a message appears indicating the command was unrecognized. For example:

```
HP9300(config)# router ip
Unrecognized command
```

Command Completion

The CLI supports command completion, so you do not need to enter the entire name of a command or option. As long as you enter enough characters of the command or option name to avoid ambiguity with other commands or options, the CLI understands what you are typing.

Scroll Control

By default, the CLI uses a page mode to paginate displays that are longer than the number of rows in your terminal emulation window. For example, if you display a list of all the commands at the global CONFIG level but your terminal emulation window does not have enough rows to display them all at once, the page mode stops the display and lists your choices for continuing the display.

Here is an example:

```
aaa
all-client
appletalk
arp
boot
```

some lines omitted for brevity...

```
ipx
lock-address
logging
mac
--More--, next page: Space, next line: Return key, quit: Control-c
```

The software provides the following scrolling options:

- Press the Space bar to display the next page (one screen at a time).
- Press the Return or Enter key to display the next line (one line at a time).
- Press CTRL + C to cancel the display.

Line Editing Commands

The CLI supports the following line editing commands. To enter a line-editing command, use the CTRL-key combination for the command by pressing and holding the CTRL key, then pressing the letter associated with the command.

Table 2.3: CLI Line Editing Commands

Ctrl-Key Combination	Description
Ctrl-A	Moves to the first character on the command line.
Ctrl-B	Moves the cursor back one character.
Ctrl-C	Escapes and terminates command prompts and ongoing tasks (such as lengthy displays), and displays a fresh command prompt.
Ctrl-D	Deletes the character at the cursor.
Ctrl-E	Moves to the end of the current command line.
Ctrl-F	Moves the cursor forward one character.
Ctrl-K	Deletes all characters from the cursor to the end of the command line.
Ctrl-L; Ctrl-R	Repeats the current command line on a new line.
Ctrl-N	Enters the next command line in the history buffer.
Ctrl-P	Enters the previous command line in the history buffer.
Ctrl-U; Ctrl-X	Deletes all characters from the cursor to the beginning of the command line.
Ctrl-W	Deletes the last word you typed.
Ctrl-Z	Moves from any CONFIG level of the CLI to the Privileged EXEC level; at the Privileged EXEC level, moves to the User EXEC level.

For a complete list of CLI commands and syntax information for each command, see the *Command Line Interface Reference*.

Logging On Through the Web Management Interface

To use the Web management interface, open a web browser and enter the IP address of the HP device in the Location or Address field. The web browser contacts the HP device and displays a login dialog, as shown in Figure 2.12.

NOTE: If you are unable to connect with the Routing Switch through a Web browser due to a proxy problem, it may be necessary to set your Web browser to direct Internet access instead of using a proxy. For information on how to change a proxy setting, refer to the online help provided with your Web browser.

Figure 2.12 Web management interface login dialog

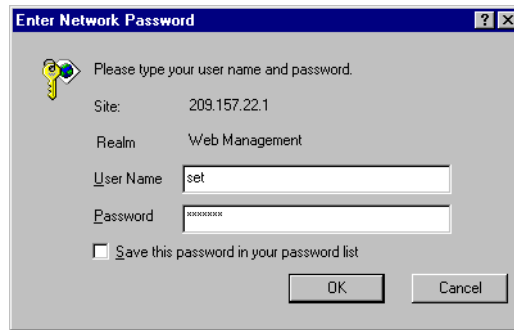

By default, you can use the user name “get” and the default read-only password “public” for read-only access. However, for read-write access, you must enter “set” for the user name, and enter a read-write community string that you have configured on the device for the password. There is no default read-write community string. You must add one. See the *Security Guide*.

As an alternative to using the SNMP community strings to log in, you can configure the device to secure Web management access using local user accounts, a RADIUS authentication server, or a TACACS/TACACS+ server.

On the HP 9304M, HP 9308M, or HP 9315M, if you have configured a greeting banner (using the **banner motd** CLI command), a panel with the greeting is displayed first. Click on the Login link to proceed to the Login dialog. Here is an example of the greeting panel:



[\[Login\]](#)

Using the Web Management Interface

When you log into a device, the System configuration panel is displayed. This panel allows you to enable or disable major system features. You can return to this panel from any other panel by selecting the [Home](#) link.

The [Site Map](#) link gives you a view of all available options on a single screen.

The left pane of the Web management interface window contains a “tree view,” similar to the one found in Windows Explorer. Configuration options are grouped into folders in the tree view. These folders, when expanded, reveal additional options. To expand a folder, click on the plus sign to the left of the folder icon.

You can configure the appearance of the Web management interface by using one of the following methods.

USING THE CLI

Using the CLI, you can modify the appearance of the Web management interface with the **web-management** command.

To cause the Web management interface to display the List view by default:

```
HP9300(config)# web-management list-menu
```

To disable the front panel frame:

```
HP9300(config)# no web-management front-panel
```

When you save the configuration with the **write memory** command, the changes will take place the next time you start the Web management interface, or if you are currently running the Web management interface, the changes will take place when you click the Refresh button on your browser.

USING THE WEB MANAGEMENT INTERFACE

1. Click on the plus sign next to Configure in the tree view to expand the list of configuration options.
2. Click on the plus sign next to System in the tree view to expand the list of system configuration links.
3. Click on the plus sign next to Management in the tree view to expand the list of system management links.
4. Click on the Web Preference link to display the Web Management Preferences panel.
5. Enable or disable elements on the Web management interface by clicking on the appropriate radio buttons on the panel. The following figure identifies the elements you can change.

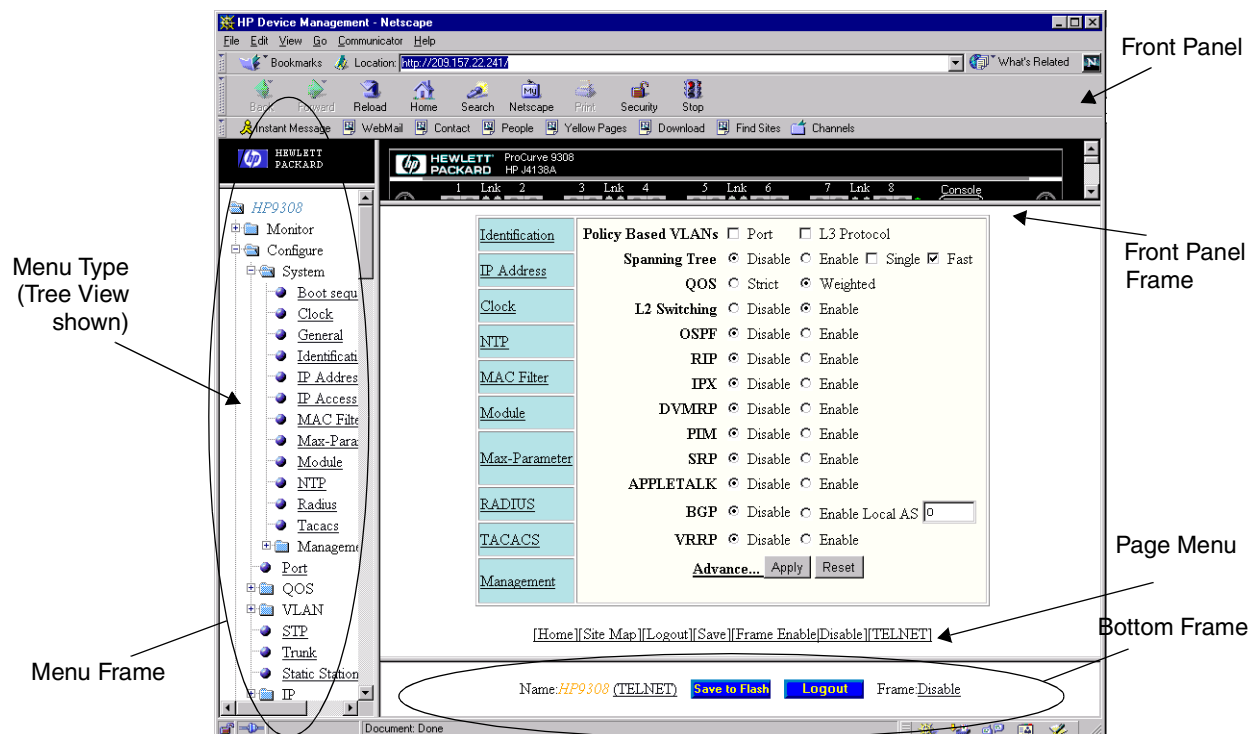

NOTE: The tree view is available when you use the Web management interface with Netscape 4.0 or higher or Internet Explorer 4.0 or higher browsers. If you use the Web management interface with an older browser, the Web management interface displays the List view only, and the Web Management Preferences panel does not include an option to display the tree view.

6. When you have finished, click the Apply button on the panel, then click the Refresh button on your browser to activate the changes.
7. To save the configuration, click the plus sign next to the Command folder, then click the Save to Flash link.

NOTE: The only changes that become permanent are the settings to the Menu Type and the Front Panel Frame. Any other elements you enable or disable will go back to their default settings the next time you start the Web management interface.

Swapping Modules

After you physically insert a module into a Chassis device, you need to enter the location and type of module in the software, unless you either reboot the device or are replacing one module with another of the same type.

Slots on the HP 9304M are numbered 1 – 4, from top to bottom.

Slots on the HP 9308M are numbered 1 – 8, from left to right.

Slots on the HP 9315M are numbered 1 – 15, from left to right.

See “Slot and Port Numbers” on page 10-7 for more information about slot and port numbering.

NOTE: If the slot has never contained a module or you are swapping in exactly the same type of module, you do not need to use the **module** command. The slot requires configuration only if it has already been configured for another type of module.

USING THE CLI

To add a module to a Chassis device:

```
HP9300(config)# module 3 24-port-copper-module
```

Syntax: module <slot-num> <module-type>

The <slot-num> parameter indicates the Chassis device slot number.

The <module-type> parameter can be one of the following. You can, of course, take advantage of the CLI's support for abbreviated command and parameter names.

NOTE: Some module strings apply to more than one module. This is because the slot configuration does not differ based on the physical layer. For example, a slot does not distinguish between an 8-port LX Fiber module and 8-port SX Fiber module. However, the software does indicate the physical layer type when you display module information. For example, the output of the **show module** command indicates the physical layer types of each module.

Table 2.4: Module Options

Module Type	Part Number and Description	Module String
Redundant Management modules (MII and MIV)	J4845A HP ProCurve 9300 GigLX Redundant Management Module (8-port)	8-port-gig-management-module
	J4846A HP ProCurve 9300 GigSX Redundant Management Module (8-port)	8-port-gig-management-module
	J4847A HP ProCurve 9300 Redundant Management Module (0-port)	0-port-management-module
	J4857A HP ProCurve 9300 Mini-GBIC Redundant Management Module (8-port)	8-port-gig-m4-management-module <i>(current product as of June 2002)</i>
Management modules (MI) (HP 9304M and HP 9308M only. These modules will not work on the HP 9315M)	J4141A ProCurve 9300 10/100 Management Module (16-port)	16-port-copper-management-module
	J4144A HP ProCurve 9300 Gigabit SX Management Module (8-port)	8-port-gig-management-module
	J4146A HP ProCurve 9300 Gigabit 4LX/4SX Management Module (8-port)	8-port-gig-management-module

Table 2.4: Module Options (Continued)

Module Type	Part Number and Description	Module String
Unmanaged modules	J4842A ProCurve 9300 1000Base-T Module (8-port)	8-port-gig-copper-module <i>(current product as of June 2002)</i>
	J4140A HP ProCurve 9300 10/100 Module (24-port)	24-port-copper-module <i>(current product as of June 2002)</i>
	J4142A HP ProCurve 9300 100Base FX Module (24-port MT-RJ)	24-port-100fx-module <i>(current product as of June 2002)</i>
	J4143A HP ProCurve 9300 Gigabit SX Module (8-port)	8-port-gig-module
	J4145A HP ProCurve 9300 Gigabit 4LX/4SX Module (8-port)	8-port-gig-module
	J4844A HP ProCurve 9300 GigLX Module (8-port)	8-port-gig-module
	J4856A HP ProCurve 9300 Mini-GBIC Module (8-port)	8-port-gig-module <i>(current product as of June 2002)</i>

USING THE WEB MANAGEMENT INTERFACE

To configure a chassis slot for a module:

1. Log on to the device using a valid user name and password for read-write access. The System configuration panel is displayed.
2. Click on the Module link to display the Module panel, as shown in the following example.

Module

Slot	Module	Status	Ports	Starting MAC	
1	8 Port Gig Management Module	OK	8	00e0.52f0.4f00	Delete
2	None				Delete
3	24 Port Copper Module	OK	24	00e0.52f0.4f40	Delete
4	24 Port Copper Module	OK	24	00e0.52f0.4f60	Delete
5	None				Delete
6	None				Delete
7	None				Delete
8	None				Delete

[\[Add Module\]](#)

[\[Home\]](#) [\[Site Map\]](#) [\[Logout\]](#) [\[Save\]](#) [\[Frame Enable\]](#) [\[Disable\]](#) [\[TELNET\]](#)

3. Click the Add Module link to display the following panel.

Module

Slot:	1
Module Type:	8-port-gig-module

[\[Show\]](#)

[\[Home\]](#) [\[Site Map\]](#) [\[Logout\]](#) [\[Save\]](#) [\[Frame Enable\]](#) [\[Disable\]](#) [\[TELNET\]](#)

4. Select slot number from the Slot pulldown menu.
 - Slots on the HP 9304M are numbered 1 – 4, from top to bottom.
 - Slots on the HP 9308M are numbered 1 – 8, from left to right.
 - Slots on the HP 9315M are numbered 1 – 15, from left to right.
5. Select the module type from the Module Type pulldown menu.
6. Click the Add button to save the change to the device's running-config file.

7. Select the **Save** link at the bottom of the dialog. Select Yes when prompted to save the configuration change to the startup-config file on the device's flash memory.

Next Steps

Once the initial installation steps are completed, you may want to use the following information:

For this Information:	Refer to the:	On the:
Configuring and managing Redundant Management modules	<i>Installation and Getting Started Guide (for Software Release 7.5.x or greater)</i>	Documentation CD-ROM (kit # 5065-6591, May 2002; or a later version.) — or — HP ProCurve Website (<i>see below</i>).
Downloading Routing Switch software updates	<i>Installation and Getting Started Guide (for Software Release 7.5.x or greater)*</i>	— Same —
Proceeding with enabling routing protocols and configuring specific features on the Routing Switches	Chapter titled "Configuring Basic Features" in the <i>Installation and Getting Started Guide</i>	— Same —
Finding the configuration details for all routing protocols and advanced VLAN features	<i>Advanced Configuration and Management Guide</i>	— Same —
To secure management access to your routing switch, and to protect against Denial of Service (DOS) attacks	<i>Security Guide</i>	— Same —
To learn more about a specific CLI command and its syntax	<i>Command Line Interface Reference</i>	— Same —
* This information is also included in the latest Routing Switch release notes, available only on the HP ProCurve website. (See below.)		

To access the HP ProCurve Website

Go to:

<http://www.hp.com/go/hpprocurve>

Click on **technical support**, then **manuals**.

Appendix A

Hardware Specifications

The HP 9315M, HP 9308M, and HP 9304M Routing Switches provide second generation, hardware-based Layer 2/3/4 switching and multi-protocol routing on a single, chassis-based platform, as shown in Figure A.1 and Figure A.2, respectively.

Enterprises and Internet service providers (ISPs) can use these Routing Switches to build very high-performance, end-to-end packet networks that provide the Quality of Service (QoS) needed to support delay-sensitive traffic. Designed for use in collapsed backbone data centers, server farms, and wiring closets, the HP ProCurve Series 9300M routing switches deliver high-density Gigabit Ethernet ports and 10/100 Mbps ports and provide performance of up to 178,000,000 packets per second, depending on which device you use.

Chassis Modules

Each slot of the HP 9315M, HP 9308M, and HP 9304M can be populated by either a switch module or a management module. All non-management modules (those without a serial management port), are referred to as **switch** modules.

Each system requires at least one **management** module. Management modules are available with 10/100 Mbps, 100 Mbps fiber ports or Gigabit Ethernet ports and provide a serial port for console access. Management modules also provide additional port density to the system. The management module can be installed within any slot.

For added redundancy and reliability, you can install two Redundant Management modules (MII or MIV) in a Chassis device. One of the Redundant Management modules is the active module while the other waits in standby mode to assume operation if the active module becomes unavailable. See “Using Redundant Management Modules” on page 3-1 for more information.

Redundant Management Modules. For redundant management capability, the HP 9315M, HP 9308M, and HP 9304M can be populated with any of the following Redundant Management modules (MII or MIV) in a chassis device.

NOTE: You can provide redundant management in your Routing Switch by installing one M2 management module and one M4 management module. However, for reasons related to performance and memory availability, HP recommends that you provide for redundant management by using either two M2 modules or two M4 modules.

- J4857A HP Procurve 9300 Mini-GBIC Redundant Management Module (8-port; MIV)
- J4845A HP ProCurve 9300 GigLX Redundant Management Module (8-port; MII)
- J4846A HP ProCurve 9300 GigSX Redundant Management Module (8-port; MII)
- J4847A HP ProCurve 9300 Redundant Management Module (0-port; MII)

Management Modules. As a management alternative for (only) the HP 9308M and HP 9304M, you can install one of these older MI management modules (*without* redundant management):

- J4141A HP ProCurve 9300 10/100 Management Module (16-port; MI)
- J4144A HP ProCurve 9300 Gigabit SX Management Module (8-port; MI)
- J4146A HP ProCurve 9300 Gigabit 4LX/4SX Management Module (8-port; MI)

NOTE: The HP 9308M and HP 9304M allow only one MI management module. (MI management modules cannot be used in the HP 9315M.) Also, software release 7.1 or greater cannot be used in MI management modules due to the flash memory size limit.

- Non-Management modules
 - J4856A HP ProCurve 9300 Mini-GBIC Module (8-port)
 - J4842A HP ProCurve 9300 1000Base-T Module (8-port)
 - J4140A HP ProCurve 9300 10/100 Module (24-port)
 - J4142A HP ProCurve 9300 100Base FX Module (24-port MT-RJ)
 - J4143A HP ProCurve 9300 Gigabit SX Module (8-port)
 - J4145A HP ProCurve 9300 Gigabit 4LX/4SX Module (8-port)
 - J4844A HP ProCurve 9300 GigLX Module (8-port)

NOTE: All 10/100 ports are auto-sensing and auto-negotiating for easy deployment into existing network topologies. Gigabit Ethernet interfaces are available in multi-mode 1000BaseSX, single-mode/multi-mode 1000BaseLX, and copper.

Figure A.1 Example of an HP 9304M Routing Switch (4-slot)

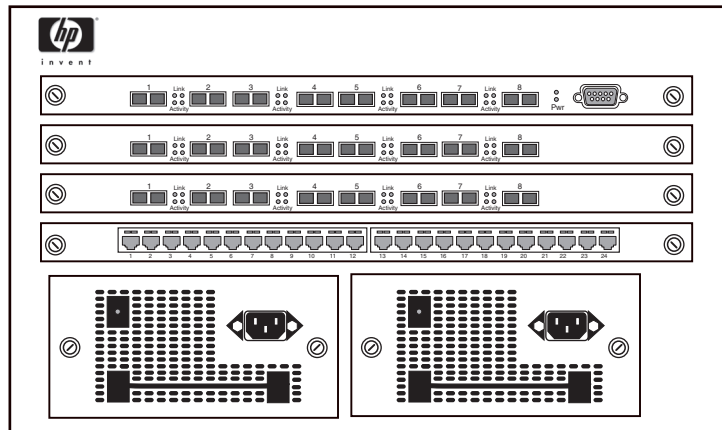
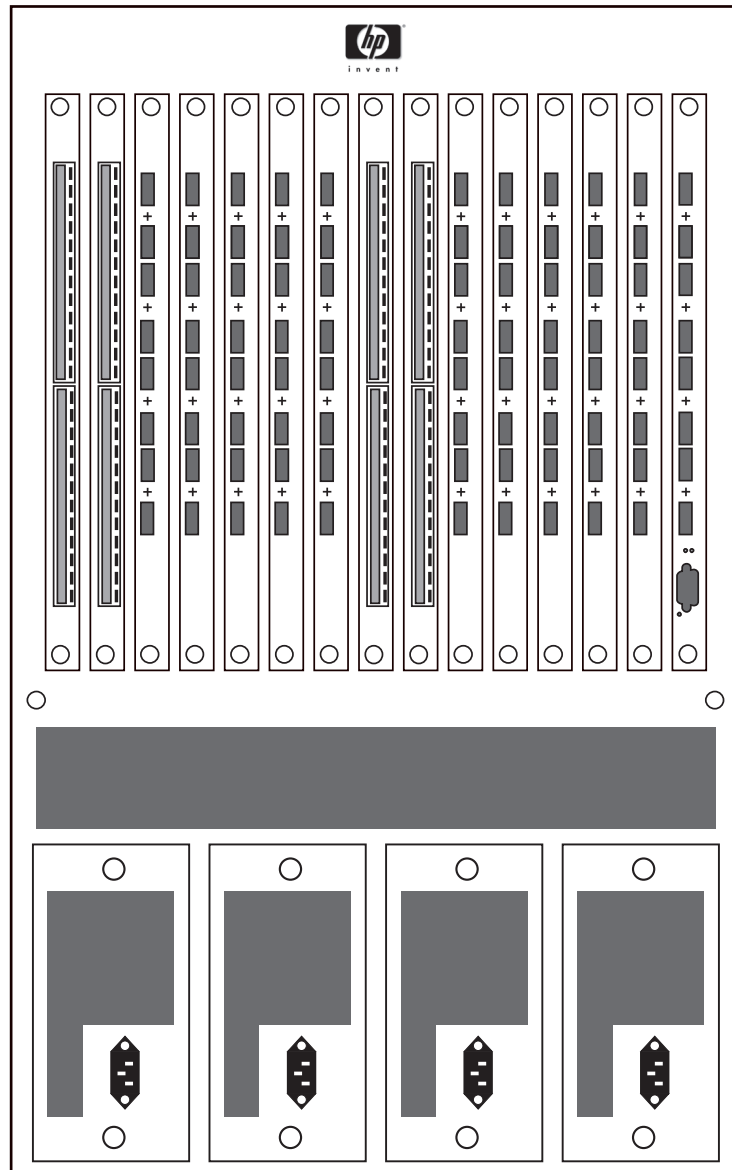

Figure A.3 Example of an HP 9315M Routing Switch (15-slot)

System Architecture

Built on a fully non-blocking architecture, the chassis platform provides switching capacity in the core and on each interface module. Each interface module utilizes a high bandwidth, shared-memory switching fabric. This local switching fabric houses the forwarding engines and includes Application Specific Integrated Circuits (ASICs) that provide packet switching functions such as priority handling. Each interface module also contains ASICs that perform high speed Layer 2, Layer 3, and Layer 4 lookups and forwarding, including IP sub-net look ups and packet modifications of IP and IPX packets. Additionally, each interface module has a full-duplex data path to the backplane that provides separate priority queues for each module destination.

Physical View

This section describes the external features of the Chassis devices.

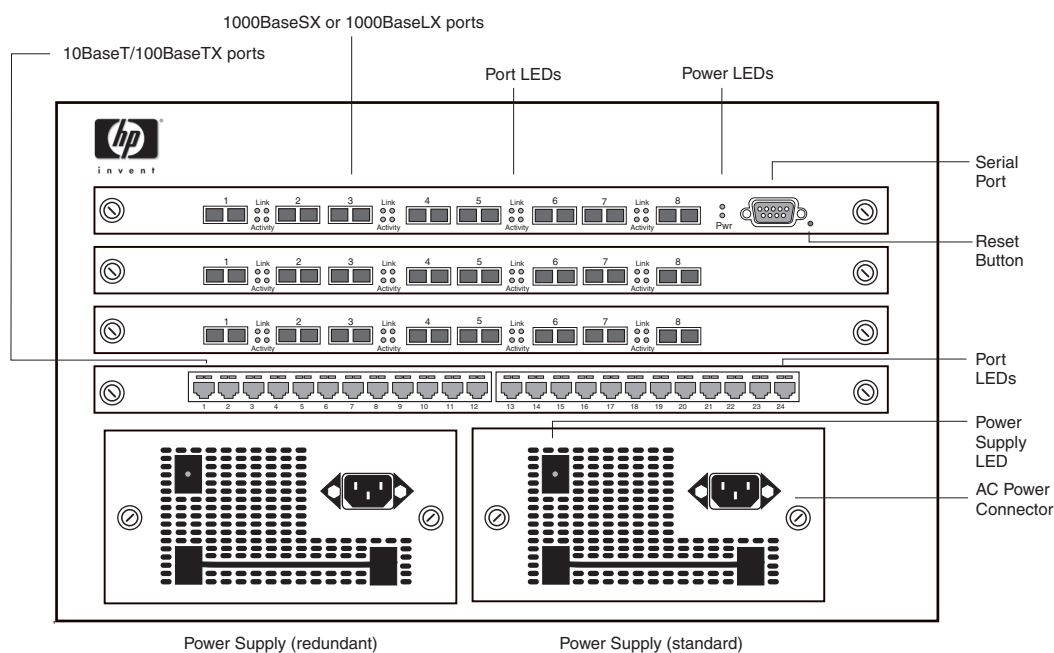
Figure A.4 Example front panel of an HP 9304M Routing Switch

NOTE: The rear panel of a Chassis device does not provide network or power connections and therefore is not shown.

Slot and Port Numbers

The port numbers on the modules in Chassis devices are labeled, but the slot numbers are not labeled.

- Slots on a 4-slot chassis are numbered 1 – 4, from top to bottom.
- Slots on an 8-slot chassis are numbered 1 – 8, from left to right.
- Slots on a 15-slot chassis are numbered 1 – 15, from left to right.

You can place a management module in any slot. The slot numbers are absolute and do not change based on the position of the management module.

To specify a port on a Chassis device, enter the slot number, a forward slash (/), and the number associated with the port on the device's front panel. For example, to assign a name to Ethernet port 8 on the module installed in Chassis slot 2, enter the following commands:

```
HP9300(config)# interface e 2/8
HP9300(config-if-2/8)# port-name pdtmarketing
```

Syntax: interface ethernet <portnum>

Syntax: port-name <string>

AC Power Connector

On Chassis devices, the power supplies are accessible from the front of the chassis, and the power supply connector is embedded within the power supply. The green LED on the power supply is lit when the power supply is properly supplying power to the system.

Fans

The 4-slot Chassis devices come with four fans. The 8-slot and 15-slot Chassis devices come with six fans.

LEDs

Each HP device is equipped with LEDs that denote port and power supply status. The tables below reflect the different port and expansion module port states.

Table A.1: Chassis 100BaseFX, 1000BaseSX/LX, and 1000BaseT LEDs

LED	Position	State	Meaning
Link	Top	On	Port is connected.
		Off	No port connection exists.
Activity	Bottom	On	Traffic is being transmitted and received on that port.
		Off	No traffic is being transmitted.
		Blinking	Traffic is being transmitted and received on that port.

Table A.2: Chassis 10BaseT/100BaseTX LEDs

LED	Position	State	Meaning
Link/Activity	Left	On	Port is connected.
		Off	No port connection exists.
		Blinking	Traffic is being transmitted and received on that port.
FDX	Right	On	The port is operating at full-duplex.
		Off	The port is operating at half-duplex.

Ports

The following port types are supported on HP Chassis devices.

1000BaseT Gigabit Copper (GC) Ports

The 1000BaseT Gigabit Copper (GC) ports are fully compliant with the IEEE 802.3ab standard and can provide Gigabit throughput over standard category-5 (“Cat-5”) copper wiring. The port connectors are RJ-45s, the same as the connectors on HP’s 10/100 modules. Thus, you can immediately deploy the GC ports without recabling.

10BaseT/100BaseTX Ports

The 10BaseT/100BaseTX ports are auto-sensing, auto-negotiating ports with RJ-45 UTP connectors. These ports accept category-5 Unshielded Twisted Pair (UTP) cables.

See “Connecting Network Devices” on page 2-19 for cabling pinouts and signalling specifics. If you prefer to avoid assembling cables by hand, you can order the proper cables from Hewlett-Packard.

NOTE: All copper ports are 10/100 Mbps auto-sensing and auto-negotiating for easy deployment into existing network topologies. Gigabit Ethernet interfaces are available in both multi-mode 1000BaseSX and single-mode 1000BaseLX.

100BaseFX Ports

The 100BaseFX ports are equipped with MT-RJ connectors and operate at 100 Mbps in full-duplex mode.

1000BaseSX Ports

The 1000BaseSX ports operate in full-duplex mode and are equipped with SC connectors on fixed-configuration modules and can be mini-GBICs with LC connectors for mini-GBIC modules that support this port type. Multi-mode fiber cabling is supported.

1000BaseLX

The 1000BaseLX ports operate in full-duplex mode and are equipped with SC connectors on fixed-configuration modules and come as mini-GBICs for mini-GBIC modules that support this port type. Both single-mode fiber (SMF) and multi-mode fiber (MMF) cabling is supported. The 1000BaseLX ports must be connected to another 1000BaseLX port. Connection to a 1000BaseSX port is not supported.

NOTE: 1000BaseSX and 1000BaseLX ports also support auto-negotiation when the auto-gig option is enabled on the system.

NOTE: 1000BaseSX and 1000BaseLX ports operate only at full-duplex.

Port Connectors

- 10/100BaseTX ports come with RJ-45 connectors.
- 100BaseFX ports come with MT-RJ connectors.
- 1000BaseSX and 1000BaseLX ports come with dual SC connectors.
- 1000BaseSX and 1000Base-LX ports also can be mini-GBIC ports with LC connectors for the modules that support mini-GBICs and these interface types.

Temperature Sensor

The redundant management modules contain an on-board temperature sensor. The software reads the sensor based on the chassis poll-time, a configurable parameter that determines how often the software polls the chassis for hardware status information.

The software is configured with a warning temperature (default 45 degrees Celsius) and a shutdown temperature (default 55 degrees Celsius). When the software reads the temperature sensor, if the temperature equals or exceeds the warning or shutdown temperature, the software does the following:

- Warning message – If the temperature of the module reaches the warning value, the software sends a Syslog message to the Syslog buffer and also to the SyslogD server, if configured. In addition, the software sends an SNMP trap to the SNMP trap receiver, if you have configured the device to use one.
- Shutdown – If the temperature matches or exceeds the shutdown temperature, the software sends a Syslog message to the Syslog buffer and also to the SyslogD server if configured. The software also sends an SNMP trap to the SNMP trap receiver, if you have configured the device to use one.

If the temperature equals or exceeds the shutdown temperature for five consecutive polls of the temperature by the software, the software shuts down the module to prevent damage.

For more information and configuration information, see “Using the Temperature Sensor” on page 4-44.

Reset Button

The reset button allows you to restart the system. The reset button is recessed to prevent it from being pushed accidentally. The reset button is located to the right of the serial port on the management module as labeled in Figure A.4.

Physical Dimensions

Table A.3: Physical dimensions for HP devices

Platform	Depth	Width	Length (Height)	Weight
15-slot Chassis device	15"	17.5"	29.75"	256 lbs. fully populated
8-slot Chassis device	15"	17.5"	23"	69.1 lbs. fully populated
4-slot Chassis device	15"	17.5"	9"	47.7 lbs. fully populated

Operating Environment

- Operating Temperature: 41° to 104° F, 5° to 40° C
- Relative Humidity: 5% – 90%, non-condensing
- Operating Altitude: 0 – 10,000 feet

Storage Environment

- Storage Temperature: -40° – 158° F, -40° – 70° C
- Storage Humidity: 95% maximum, non-condensing
- Storage Altitude: 10,000 feet (3,000 meter) maximum

Electromagnetic Emissions

- FCC Class A, Part 15
- EN55022/CISPR22 Class A
- VCCI Class A

Immunity

- EN55024/CISPR24
- Harmonics and Flicker IEC 61000-3-2/IEC 61000-3-3

Safety Agency Approvals

- UL 1950
- CUL/CSA-C22.2 No. 950 93
- TUV EN 60950, EN 60825

Laser

- Class 1 Laser Product
- Laser Klasse 1
- Complies with IEC 825-2:1993

Numerics

- 1000BaseLH port 2-7
- 1000BaseLH, dB loss required 2-20
- 1000BaseLx 2-7, A-7
- 1000BaseSx 2-7, A-7
- 1000BaseT A-6
- 100BaseFx A-7
- 9304M Routing Switch 2-10, 2-11
- 9308M Routing Switch 2-11

A

- AC power
 - connector A-5
- Access
 - CLI 2-23
 - lost password 2-15
- Access levels 2-14
- Address
 - IP 2-16
- Agency approvals A-8
- Air Flow 2-17
- Air Flow, Caution 2-3
- Altitude A-8
- Ambient temperature 2-3
- Ampere Ratings 2-3
- Architecture A-4
- Assigning
 - IP address 2-16
 - password 2-14

C

- Cable
 - length 2-20
 - Straight-through 2-12
 - straight-through 2-22
- Caution
 - grounding tap 2-2
 - Power Cord 2-2

- Caution, Air Flow 2-3
- Caution, Circuit Overload 2-3
- Caution, grounding 2-3
- Caution, grounding tap 2-5
- Caution, Power Cord 2-3
- Caution, Power Sockets 2-19
- Caution, Powering On 2-19
- Caution, Redundant Power Supply 2-2, 2-9
- Caution, set-up 2-3
- Caution, ventilation 2-3
- CESD grounding tap 2-2, 2-5, 2-13
- Chassis
 - module A-1
 - replacing power supply 2-8
 - slot and port numbers A-5
 - swapping modules 2-4
- CLI
 - access 2-23
 - access levels 2-14
 - attaching serial cable 2-12
 - command completion 2-24
 - CONFIG Level 2-14
 - line editing commands 2-25
 - logging on 2-23
 - Privileged EXEC Level 2-14
 - scroll control 2-24
 - securing access 2-15
 - User EXEC level 2-14
- Command completion
 - CLI 2-24
- CONFIG Level 2-14
- Connection, Serial 2-1
- Connections 2-21
- Connector
 - console 2-12
 - module 2-19
 - power A-5

- Console, attaching 2-12
- Console Attachment 2-12
- Console Settings 2-12
- Conventions, manual 1-1
- Cooling 2-5
- Copper Cable, grounding 2-19
- Ctrl-A 2-25
- Ctrl-B 2-25
- Ctrl-C 2-25
- Ctrl-D 2-25
- Ctrl-E 2-25
- Ctrl-F 2-25
- Ctrl-K 2-25
- Ctrl-L 2-25
- Ctrl-N 2-25
- Ctrl-P 2-25
- Ctrl-R 2-25
- Ctrl-U 2-25
- Ctrl-W 2-25
- Ctrl-X 2-25
- Ctrl-Z 2-25

D

- Desktop Installation 2-17
- Dimensions A-8

E

- Electromagnetic emissions A-8
- EMC Regulatory Statements xii
- Emissions A-8
- Enable password
 - assigning 2-15
- ESD damage, prevent 2-19

F

- Fan A-5
- Fiber
 - cabling 2-22

G

- Global CONFIG Level 2-15
- Grounding ii, 2-3, 2-13, 2-19
- Grounding tap, CESD 2-13, 2-19
- Grounding, CESD grounding tap 2-13, 2-19
- Grounding, copper cable 2-2, 2-13, 2-19

H

- Handles, Warning 2-1, 2-3, 2-17
- Hardware
 - architecture A-4
 - fan A-5
 - installation 2-1
 - LEDs A-6
 - port A-6
 - reset button A-7
 - Temperature sensor A-7
- Hot Swap 2-4
 - modules 2-5

- redundant power supply 2-8, 2-9
- Humidity A-8

I

- Installation
 - desktop 2-17
 - hardware 2-1
 - location and clearance 2-4
 - precautions 2-3
 - rack, chassis 2-17
 - summary of 2-2
- Installing a System 2-2
- Interface
 - number A-5
- Internet Explorer version required 2-27
- IP Address
 - assigning 2-1
- IP address
 - assigning 2-16

J

- J4147A Power supply 2-8, 2-9
- J4175A Power supply 2-8, 2-9

L

- LAN Connections 2-21
- Laser specifications A-8
- Lasers
 - IEC compliance xii
- LED Behavior 2-12
- LEDs A-6
- LH signal, dB loss required 2-20
- Lifting, warning 2-1
- Line editing commands 2-25
- Logging on
 - CLI 2-23
 - Web management interface 2-25

M

- Manual nomenclature 1-1
- Mask, Network 2-1
- mini-GBIC 2-6
- Mini-GBIC, cable length 2-20
- mini-GBIC, install or remove 2-7
- mini-GBIC, software version 2-6
- Module A-1
 - connectors 2-19
 - installing 2-4
 - removing 2-4
- Mounting
 - air flow 2-17
 - warning 2-17

N

- Netscape version required 2-27
- Network
 - connection 2-19

- network connections
 - troubleshooting 2-22
- Network Mask 2-1
- O**
- Operating environment A-8
- Operating temperature 2-3
- P**
- Package contents 2-1
- Password 2-14
 - assigning 2-15
 - lost
 - accessing the device 2-15
- Password, Lost 2-15
- PC
 - attaching 2-12
- Physical dimensions A-8
- Pin assignments
 - serial port 2-12
- Pinouts
 - serial port 2-14
- Port
 - hardware A-6
 - number A-5
- Power
 - connector A-5
- Power Cord 2-12
 - caution 2-3, 2-19
- Power supply
 - J4147A 2-8, 2-9
 - J4175A 2-8, 2-9
 - not interchangeable 2-8, 2-9
 - replacing 2-8
- Power supply, hot swap 2-8, 2-9
- Powering On 2-19
- Precautions, installation 2-3
- Privileged EXEC Level 2-14, 2-15
- Prompt, customizing 2-13
- Proxy problem, Web management access 2-25
- R**
- Rack installation, chassis 2-17
- Rack Mounting 2-3, 2-18
 - warning 2-3, 2-17
- Rack, Loading 2-3
- Redundant Power Supply
 - Caution 2-2
 - installing 2-8
 - removing 2-9
- Regulatory Statements xii
- Reset button A-7
- RPS
 - See Redundant Power Supply 2-2
- S**
- Scroll control 2-24
- Security
 - assigning Enable password 2-15
- Serial cable 2-12
- Serial Connection 2-1
- Serial Port Pinouts 2-14
- Service ii
- Settings, Terminal 2-12
- Set-Up, Caution 2-3
- Shock Hazard, Warning 2-19
- Shock, warning 2-4, 2-5, 2-19
- Slot Cover Plates, Air Flow 2-3, 2-5
- Slot number A-5
- State agency approvals A-8
- Storage environment A-8
- Super User 2-15
- Swapping modules 2-4
- System
 - installation 2-2
 - unpacking 2-1
- T**
- Temperature 2-3, A-8
 - sensor A-7
- Terminal Settings 2-12
- Troubleshooting network connections 2-22
- U**
- Unpacking a System 2-1
- User EXEC level 2-14
- UTP
 - cabling 2-22
- V**
- Ventilation 2-17
- Ventilation, Caution 2-3
- W**
- Warning
 - handles 2-1, 2-3, 2-17
 - rack or cabinet secured 2-3
 - system placement in rack 2-17
 - weight 2-1, 2-3, 2-18
- Warning, Electrical Shock Hazard, Warning 2-19
- Warning, shock 2-4, 2-5
- Warranty ii
- Web management interface
 - logging on 2-25
 - password 2-26
 - proxy problem 2-25
 - user name 2-26
 - using 2-26
- Weight
 - warning 2-1, 2-3, 2-17, 2-18, 2-19



Technical information in this document is subject to change without notice.

©Copyright Hewlett-Packard Company 2000-2002. All rights reserved. Reproduction, adaptation, or translation without prior written permission is prohibited except as allowed under the copyright laws.

Printed in U.S.A. June, 2002

Manual Part Number
5990-3009

