

management and  
configuration guide



hp procurve  
series 4100gl switches

[www.hp.com/go/hpprocurve](http://www.hp.com/go/hpprocurve)



# HP Procurve Series 4100GL Switches

Software Release G.05.02 or Greater

---

## Management and Configuration Guide

**© Copyright 2000-2002 Hewlett-Packard Company  
All Rights Reserved.**

This document contains information which is protected by copyright. Reproduction, adaptation, or translation without prior permission is prohibited, except as allowed under the copyright laws.

### **Publication Number**

5990-3007  
May 2002  
Edition 2

### **Applicable Product**

HP Procurve Switch 4104GL (J4887A)  
HP Procurve Switch 4108GL (J4865A)

### **Trademark Credits**

Microsoft, Windows, Windows 95, and Microsoft Windows NT are registered trademarks of Microsoft Corporation. Internet Explorer is a trademark of Microsoft Corporation. Ethernet is a registered trademark of Xerox Corporation. Netscape is a registered trademark of Netscape Corporation. Cisco® is a trademark of Cisco Systems, Inc.

### **Disclaimer**

The information contained in this document is subject to change without notice.

HEWLETT-PACKARD COMPANY MAKES NO WARRANTY OF ANY KIND WITH REGARD TO THIS MATERIAL, INCLUDING, BUT NOT LIMITED TO, THE IMPLIED WARRANTIES OF MERCHANTABILITY AND FITNESS FOR A PARTICULAR PURPOSE. Hewlett-Packard shall not be liable for errors contained herein or for incidental or consequential damages in connection with the furnishing, performance, or use of this material.

Hewlett-Packard assumes no responsibility for the use or reliability of its software on equipment that is not furnished by Hewlett-Packard.

### **Warranty**

See the Customer Support/Warranty booklet included with the product.

A copy of the specific warranty terms applicable to your Hewlett-Packard products and replacement parts can be obtained from your HP Sales and Service Office or authorized dealer.

---

# Contents

## Getting Started

<b>Contents</b> .....	xvii
<b>Introduction</b> .....	xviii
<b>Conventions</b> .....	xviii
<b>Simulating Display Output</b> .....	xix
Command Prompts .....	xix
Screen Simulations .....	xix
<b>Related Publications</b> .....	xx
<b>Getting Documentation From the Web</b> .....	xxi
<b>Sources for More Information</b> .....	xxii
<b>Need Only a Quick Start?</b> .....	xxiii

## 1 Selecting a Management Interface

<b>Contents</b> .....	1-1
<b>Overview</b> .....	1-2
<b>Understanding Management Interfaces</b> .....	1-2
<b>Advantages of Using the Menu Interface</b> .....	1-3
<b>Advantages of Using the CLI</b> .....	1-4
<b>Advantages of Using the HP Web Browser Interface</b> .....	1-5
<b>Advantages of Using HP TopTools for Hubs &amp; Switches</b> .....	1-6

## 2 Using the Menu Interface

<b>Contents</b> .....	2-1
<b>Overview</b> .....	2-2
<b>Starting and Ending a Menu Session</b> .....	2-3
How To Start a Menu Interface Session .....	2-4
How To End a Menu Session and Exit from the Console: .....	2-5
<b>Main Menu Features</b> .....	2-7

<b>Screen Structure and Navigation</b> .....	2-9
<b>Rebooting the Switch</b> .....	2-12
<b>Menu Features List</b> .....	2-14
<b>Where To Go From Here</b> .....	2-15
<b>3 Using the Command Line Interface (CLI)</b>	
<b>Contents</b> .....	3-1
<b>Overview</b> .....	3-2
<b>Accessing the CLI</b> .....	3-2
<b>Using the CLI</b> .....	3-2
Privilege Levels at Logon .....	3-3
Privilege Level Operation .....	3-4
Operator Privileges .....	3-4
Manager Privileges .....	3-5
How To Move Between Levels .....	3-7
Listing Commands and Command Options .....	3-8
Listing Commands Available at Any Privilege Level .....	3-8
Command Option Displays .....	3-10
Displaying CLI "Help" .....	3-11
Configuration Commands and the Context Configuration Modes ..	3-13
<b>CLI Control and Editing</b> .....	3-16
<b>4 Using the HP Web Browser Interface</b>	
<b>Contents</b> .....	4-1
<b>Overview</b> .....	4-2
<b>General Features</b> .....	4-3
<b>Starting an HP Web Browser Interface Session with the Switch</b> ..	4-4
Using a Standalone Web Browser in a PC or UNIX Workstation ...	4-4
Using HP TopTools for Hubs & Switches .....	4-5
<b>Tasks for Your First HP Web Browser Interface Session</b> .....	4-7
Viewing the "First Time Install" Window .....	4-7

Creating Usernames and Passwords in the Browser Interface . . . . .	4-8
Using the Passwords . . . . .	4-10
Using the User Names . . . . .	4-10
If You Lose a Password . . . . .	4-11
Online Help for the HP Web Browser Interface . . . . .	4-11
<b>Support/Mgmt URLs Feature . . . . .</b>	<b>4-12</b>
Support URL . . . . .	4-13
Help and the Management Server URL . . . . .	4-13
<b>Status Reporting Features . . . . .</b>	<b>4-15</b>
The Overview Window . . . . .	4-15
The Port Utilization and Status Displays . . . . .	4-16
Port Utilization . . . . .	4-16
Port Status . . . . .	4-18
The Alert Log . . . . .	4-19
Sorting the Alert Log Entries . . . . .	4-19
Alert Types . . . . .	4-20
Viewing Detail Views of Alert Log Entries . . . . .	4-21
The Status Bar . . . . .	4-22
Setting Fault Detection Policy . . . . .	4-23

## 5 Switch Memory and Configuration

<b>Contents . . . . .</b>	<b>5-1</b>
<b>Overview . . . . .</b>	<b>5-2</b>
<b>Overview of Configuration File Management . . . . .</b>	<b>5-2</b>
<b>Using the CLI To Implement Configuration Changes . . . . .</b>	<b>5-4</b>
<b>Using the Menu and Web Browser Interfaces To Implement Configuration Changes . . . . .</b>	<b>5-8</b>
Using the Menu Interface To Implement Configuration Changes . . .	5-9
Using Save and Cancel in the Menu Interface . . . . .	5-9
Rebooting from the Menu Interface . . . . .	5-10
Using the Web Browser Interface To Implement Configuration Changes . . . . .	5-11
<b>Using Primary and Secondary Flash Image Options . . . . .</b>	<b>5-12</b>
Displaying the Current Flash Image Data . . . . .	5-12
OS Downloads . . . . .	5-14
Local OS Replacement and Removal . . . . .	5-15

Rebooting the Switch .....	5-17
Operating Notes .....	5-19
<b>6 Interface Access, System Information, and Friendly Port Names</b>	
<b>Contents</b> .....	6-1
<b>Overview</b> .....	6-2
<b>Interface Access: Console/Serial Link, Web, and Inbound Telnet</b> .....	6-3
Menu: Modifying the Interface Access .....	6-4
CLI: Modifying the Interface Access .....	6-5
<b>Denying Interface Access by Terminating Remote Management Sessions</b> .....	6-8
<b>System Information</b> .....	6-9
Menu: Viewing and Configuring System Information .....	6-10
CLI: Viewing and Configuring System Information .....	6-11
Web: Configuring System Parameters .....	6-14
<b>Using Friendly (Optional) Port Names</b> .....	6-15
Configuring and Operating Rules for Friendly Port Names .....	6-15
Configuring Friendly Port Names .....	6-16
Displaying Friendly Port Names with Other Port Data .....	6-18
<b>7 Configuring IP Addressing</b>	
<b>Contents</b> .....	7-1
<b>Overview</b> .....	7-2
<b>IP Configuration</b> .....	7-3
Just Want a Quick Start with IP Addressing? .....	7-4
IP Addressing with Multiple VLANs .....	7-4
IP Addressing in a Stacking Environment .....	7-5
Menu: Configuring IP Address, Gateway, and Time-To-Live (TTL) ..	7-5
CLI: Configuring IP Address, Gateway, and Time-To-Live (TTL) ....	7-7
Web: Configuring IP Addressing .....	7-9



How IP Addressing Affects Switch Operation .....	7-9
DHCP/Bootp Operation .....	7-10
Network Preparations for Configuring DHCP/Bootp .....	7-13
<b>IP Preserve: Retaining VLAN-1 IP Addressing Across Configuration</b>	
<b>File Downloads</b> .....	7-14
<b>Globally Assigned IP Network Addresses</b> .....	7-18

## 8 Time Protocols

<b>Contents</b> .....	8-1
<b>Overview</b> .....	8-2
TimeP Time Synchronization .....	8-2
SNTP Time Synchronization .....	8-2
<b>Overview: Selecting a Time Synchronization Protocol or</b>	
<b>Turning Off Time Protocol Operation</b> .....	8-3
General Steps for Running a Time Protocol on the Switch: .....	8-3
Disabling Time Synchronization .....	8-4
<b>SNTP: Viewing, Selecting, and Configuring</b> .....	8-4
Menu: Viewing and Configuring SNTP .....	8-5
CLI: Viewing and Configuring SNTP .....	8-8
Viewing the Current SNTP Configuration .....	8-8
Configuring (Enabling or Disabling) the SNTP Mode .....	8-9
<b>TimeP: Viewing, Selecting, and Configuring</b> .....	8-13
Menu: Viewing and Configuring TimeP .....	8-14
CLI: Viewing and Configuring TimeP .....	8-16
Viewing the Current TimeP Configuration .....	8-16
Configuring (Enabling or Disabling) the TimeP Mode .....	8-17
<b>SNTP Unicast Time Polling with Multiple SNTP Servers</b> .....	8-20
Address Prioritization .....	8-21
Adding and Deleting SNTP Server Addresses .....	8-21
Menu Interface Operation with Multiple SNTP Server	
Addresses Configured .....	8-22
<b>SNTP Messages in the Event Log</b> .....	8-23

## 9 Optimizing Traffic Flow with Port Controls, Port Trunking, and Port-Based Priority

<b>Contents</b> .....	9-1
<b>Overview</b> .....	9-2
<b>Viewing Port Status and Configuring Port Parameters</b> .....	9-2
Menu: Viewing Port Status and Configuring Port Parameters .....	9-5
CLI: Viewing Port Status and Configuring Port Parameters .....	9-6
Web: Viewing Port Status and Configuring Port Parameters .....	9-9
<b>Port Trunking</b> .....	9-10
Series 4100GL switches Port Trunk Features and Operation .....	9-11
Trunk Configuration Methods .....	9-12
Menu: Viewing and Configuring a Static Trunk Group .....	9-16
CLI: Viewing and Configuring a Static or Dynamic Port Trunk Group .....	9-18
Using the CLI To View Port Trunks .....	9-18
Using the CLI To Configure a Static or Dynamic Trunk Group .....	9-21
Web: Viewing Existing Port Trunk Groups .....	9-24
Trunk Group Operation Using LACP .....	9-25
Default Port Operation .....	9-27
LACP Notes and Restrictions .....	9-28
Trunk Group Operation Using the “Trunk” Option .....	9-30
Trunk Operation Using the “FEC” Option .....	9-30
How the Switch Lists Trunk Data .....	9-31
Outbound Traffic Distribution Across Trunked Links .....	9-31
<b>Configuring Port-Based Priority for Incoming Packets</b> .....	9-33
The Role of 802.1Q VLAN Tagging .....	9-33
Outbound Port Queues and Packet Priority Settings .....	9-34
Operating Rules for Port-Based Priority on Series 4100GL Switches .....	9-35
Configuring and Viewing Port-Based Priority .....	9-36
Messages Related to Prioritization .....	9-37
Troubleshooting Prioritization .....	9-37

## 10 Configuring for Network Management Applications

<b>Contents</b> .....	10-1
<b>Using SNMP Tools To Manage the Switch</b> .....	10-2

Overview .....	10-2
SNMP Management Features .....	10-3
Configuring for SNMP Access to the Switch .....	10-3
SNMP Communities .....	10-4
Menu: Viewing and Configuring SNMP Communities .....	10-4
CLI: Viewing and Configuring Community Names .....	10-6
Trap Receivers and Authentication Traps .....	10-8
Advanced Management: RMON .....	10-12
<b>CDP</b> .....	10-13
Introduction .....	10-13
CDP Terminology .....	10-14
General CDP Operation .....	10-15
Outgoing Packets .....	10-15
Incoming CDP Packets .....	10-16
Configuring CDP on the Switch .....	10-19
Viewing the Switch's Current CDP Configuration .....	10-20
Viewing the Switch's Current CDP Neighbors Table .....	10-20
Clearing (Resetting) the CDP Neighbors Table .....	10-21
Configuring CDP Operation .....	10-22
Effect of Spanning Tree (STP) On CDP Packet Transmission ....	10-24
How the Switch Selects the IP Address To Include in	
Outbound CDP Packets .....	10-25
CDP Neighbor Data and MIB Objects .....	10-26
Operating Notes .....	10-28

## **11 Port-Based Virtual LANs (VLANs) and GVRP**

<b>Contents</b> .....	11-1
<b>Overview</b> .....	11-2
<b>Port-Based Virtual LANs (Static VLANs)</b> .....	11-3
Overview of Using VLANs .....	11-6
VLAN Support and the Default VLAN .....	11-6
The Primary VLAN .....	11-6
Per-Port Static VLAN Configuration Options .....	11-7
General Steps for Using VLANs .....	11-9
Notes on Using VLANs .....	11-9

Menu: Configuring VLAN Parameters .....	11-10
To Change VLAN Support Settings .....	11-10
Adding or Editing VLAN Names .....	11-12
Adding or Changing a VLAN Port Assignment .....	11-13
CLI: Configuring VLAN Parameters .....	11-15
Web: Viewing and Configuring VLAN Parameters .....	11-21
VLAN Tagging Information .....	11-22
The Secure Management VLAN .....	11-26
Preparation .....	11-27
Configuration .....	11-28
Operating Notes for Management VLANs .....	11-29
Effect of VLANs on Other Switch Features .....	11-30
Spanning Tree Operation with VLANs .....	11-30
IP Interfaces .....	11-30
VLAN MAC Addresses .....	11-31
Port Trunks .....	11-31
Port Monitoring .....	11-31
VLAN Restrictions .....	11-31
<b>GVRP .....</b>	<b>11-33</b>
General Operation .....	11-34
Per-Port Options for Handling GVRP “Unknown VLANs” .....	11-36
Per-Port Options for Dynamic VLAN Advertising and Joining .....	11-38
GVRP and VLAN Access Control .....	11-40
Port-Leave From a Dynamic VLAN .....	11-40
Planning for GVRP Operation .....	11-41
Configuring GVRP On a Switch .....	11-41
Menu: Viewing and Configuring GVRP .....	11-42
CLI: Viewing and Configuring GVRP .....	11-43
Web: Viewing and Configuring GVRP .....	11-46
GVRP Operating Notes .....	11-46

## **12 Multimedia Traffic Control with IP Multicast (IGMP)**

<b>Contents .....</b>	<b>12-1</b>
<b>Overview .....</b>	<b>12-2</b>
<b>General Operation and Features .....</b>	<b>12-3</b>
IGMP Terms .....	12-4

IGMP Operating Features .....	12-5
Basic Operation .....	12-5
Enhancements .....	12-5
<b>CLI: Configuring and Displaying IGMP</b> .....	12-6
<b>Web: Enabling or Disabling IGMP</b> .....	12-10
<b>How IGMP Operates</b> .....	12-11
Operation With or Without IP Addressing .....	12-12
Automatic Fast-Leave IGMP .....	12-13
Forced Fast-Leave IGMP .....	12-14
Configuration Options for Forced Fast-Leave .....	12-15
Listing the Forced Fast-Leave Configuration .....	12-15
Configuring Per-Port Forced Fast-Leave IGMP .....	12-17
<b>Using the Switch as Querier</b> .....	12-18
<b>The Switch Excludes Well-Known or Reserved Multicast     Addresses from IP Multicast Filtering</b> .....	12-19
<b>13 802.1w Rapid Spanning Tree Protocol (RSTP) and 802.1d Spanning Tree Protocol (STP)</b>	
<b>Contents</b> .....	13-1
<b>Overview</b> .....	13-2
<b>How Spanning Tree Operates</b> .....	13-4
<b>Spanning Tree Options: RSTP (802.1w) and STP (802.1d)</b> .....	13-5
RSTP (802.1w) .....	13-5
STP (802.1d) .....	13-6
<b>Configuring Rapid Reconfiguration Spanning Tree (RSTP)</b> .....	13-7
Overview .....	13-7
Transitioning from STP to RSTP .....	13-8
Configuring RSTP .....	13-9
Optimizing the RSTP Configuration .....	13-9
CLI: Configuring RSTP .....	13-10
Menu: Configuring RSTP .....	13-16
Web: Enabling or Disabling RSTP .....	13-18
<b>802.1p Spanning-Tree Protocol (STP)</b> .....	13-19
Menu: Configuring 802.1D STP .....	13-19
CLI: Configuring 802.1D STP .....	13-22

STP Fast Mode .....	13-26
Fast-Uplink Spanning Tree Protocol (STP) .....	13-27
Terminology .....	13-29
Operating Rules for Fast Uplink .....	13-30
Menu: Viewing and Configuring Fast-Uplink STP .....	13-31
CLI: Viewing and Configuring Fast-Uplink STP .....	13-37
Operating Notes .....	13-40
<b>Web: Enabling or Disabling STP .....</b>	<b>13-41</b>

## 14 HP Procurve Stack Management

<b>Contents .....</b>	<b>14-1</b>
<b>Overview .....</b>	<b>14-2</b>
<b>Operation .....</b>	<b>14-3</b>
Which Devices Support Stacking? .....	14-4
Components of HP Procurve Stack Management .....	14-5
General Stacking Operation .....	14-5
Operating Rules for Stacking .....	14-6
<b>Configuring Stack Management .....</b>	<b>14-9</b>
Overview of Configuring and Bringing Up a Stack .....	14-9
Using the Menu Interface To View Stack Status and Configure Stacking .....	14-13
Using the Menu Interface To View and Configure a Commander Switch .....	14-13
Using the Menu To Manage a Candidate Switch .....	14-15
Using the Commander To Manage The Stack .....	14-17
Using the Commander To Access Member Switches for Configuration Changes and Monitoring Traffic .....	14-23
Converting a Commander or Member to a Member of Another Stack .....	14-24
Monitoring Stack Status .....	14-25
Using the CLI To View Stack Status and Configure Stacking .....	14-29
Using the CLI To View Stack Status .....	14-31
Using the CLI To Configure a Commander Switch .....	14-33
Adding to a Stack or Moving Switches Between Stacks .....	14-35
Using the CLI To Remove a Member from a Stack .....	14-40
Using the CLI To Access Member Switches for Configuration Changes and Traffic Monitoring .....	14-42
SNMP Community Operation in a Stack .....	14-43

Using the CLI To Disable or Re-Enable Stacking .....	14-44
Transmission Interval .....	14-44
Stacking Operation with Multiple VLANs Configured .....	14-44
Web: Viewing and Configuring Stacking .....	14-45
Status Messages .....	14-46

## A File Transfers

<b>Contents</b> .....	A-1
<b>Overview</b> .....	A-2
<b>Downloading an Operating System (OS)</b> .....	A-2
General OS Download Rules .....	A-2
Using TFTP To Download an OS Image from a Server .....	A-3
Menu: TFTP Download from a Server to Primary Flash .....	A-4
CLI: TFTP Download from a Server to Primary or Secondary Flash .....	A-5
Using Xmodem to Download an OS Image From a PC or UNIX Workstation .....	A-6
Menu: Xmodem Download to Primary Flash .....	A-7
CLI: Xmodem Download from a PC or Unix Workstation to Primary or Secondary Flash .....	A-8
Switch-to-Switch Download .....	A-9
Menu: Switch-to-Switch Download to Primary Flash .....	A-9
CLI: Switch-To-Switch Downloads .....	A-10
Using the HP TopTools for Hubs & Switches Utility .....	A-11
<b>Troubleshooting TFTP Downloads</b> .....	A-12
<b>Transferring Switch Configurations</b> .....	A-13
<b>Copying Diagnostic Data to a Remote Host, PC, or Unix Workstation</b> .....	A-16
Copying Command Output to a Destination Device .....	A-16
Copying Event Log Output to a Destination Device .....	A-17
Copying Crash Data Content to a Destination Device .....	A-17
Copying Crash Log Data Content to a Destination Device ....	A-18

## B Monitoring and Analyzing Switch Operation

<b>Contents</b> .....	B-1
<b>Overview</b> .....	B-2

<b>Status and Counters Data</b> .....	B-3
Menu Access To Status and Counters .....	B-4
General System Information .....	B-5
Menu Access .....	B-5
CLI Access .....	B-5
Switch Management Address Information .....	B-6
Menu Access .....	B-6
CLI Access .....	B-6
Module Information .....	B-7
Menu: Displaying Port Status .....	B-7
CLI Access .....	B-7
Port Status .....	B-8
Menu: Displaying Port Status .....	B-8
CLI Access .....	B-8
Web Access .....	B-8
Viewing Port and Trunk Group Statistics and Flow Control Status .	B-9
Menu Access to Port and Trunk Statistics .....	B-10
CLI Access To Port and Trunk Group Statistics .....	B-11
Web Browser Access To View Port and Trunk Group Statistics	B-11
Viewing the Switch's MAC Address Tables .....	B-12
Menu Access to the MAC Address Views and Searches .....	B-13
CLI Access for MAC Address Views and Searches .....	B-15
Spanning Tree Protocol (STP) Information .....	B-17
Menu Access to STP Data .....	B-17
CLI Access to STP Data .....	B-18
Internet Group Management Protocol (IGMP) Status .....	B-19
VLAN Information .....	B-20
Web Browser Interface Status Information .....	B-22
<b>Port and Static Trunk Monitoring Features</b> .....	B-23
Menu: Configuring Port and Static Trunk Monitoring .....	B-24
CLI: Configuring Port and Static Trunk Monitoring .....	B-26
Web: Configuring Port Monitoring .....	B-28

## C Troubleshooting

<b>Contents</b> .....	C-1
<b>Overview</b> .....	C-2
<b>Troubleshooting Approaches</b> .....	C-3



<b>Browser or Telnet Access Problems</b> .....	C-4
<b>Unusual Network Activity</b> .....	C-6
General Problems .....	C-6
Prioritization Problems .....	C-7
CDP Problems .....	C-7
IGMP-Related Problems .....	C-8
LACP-Related Problems .....	C-9
Port-Based Access Control (802.1x)-Related Problems .....	C-9
Radius-Related Problems .....	C-12
Spanning-Tree Protocol (STP) and Fast-Uplink Problems .....	C-14
SSH-Related Problems .....	C-15
Stacking-Related Problems .....	C-16
TACACS-Related Problems .....	C-16
TimeP, SNTP, or Gateway Problems .....	C-18
VLAN-Related Problems .....	C-18
<b>Using the Event Log To Identify Problem Sources</b> .....	C-21
Menu: Entering and Navigating in the Event Log .....	C-22
CLI: .....	C-23
<b>Diagnostic Tools</b> .....	C-24
Port Auto-Negotiation .....	C-24
Ping and Link Tests .....	C-24
Web: Executing Ping or Link Tests .....	C-26
CLI: Ping or Link Tests .....	C-27
Displaying the Configuration File .....	C-29
CLI: Viewing the Configuration File .....	C-29
<b>Listing Switch Configuration and Operation Details for Help in Troubleshooting</b> .....	C-30
Web: Viewing the Configuration File .....	C-32
CLI Administrative and Troubleshooting Commands .....	C-33
<b>Restoring the Factory-Default Configuration</b> .....	C-34
CLI: Resetting to the Factory-Default Configuration .....	C-34
Clear/Reset: Resetting to the Factory-Default Configuration ..	C-34
<b>Restoring a Flash Image</b> .....	C-35
<b>D MAC Address Management</b>	
<b>Overview</b> .....	D-1
<b>Determining MAC Addresses</b> .....	D-2

Menu: Viewing the Switch's MAC Addresses . . . . . D-3

CLI: Viewing the Port and VLAN MAC Addresses . . . . . D-4

**E Daylight Savings Time on HP Procurve Switches**

**Index**

# Getting Started

---

## Contents

### Getting Started

<b>Introduction</b> .....	xiv
<b>Conventions</b> .....	xiv
<b>Simulating Display Output</b> .....	xv
Command Prompts .....	xv
Screen Simulations .....	xv
<b>Related Publications</b> .....	xvi
<b>Getting Documentation From the Web</b> .....	xvii
<b>Sources for More Information</b> .....	xviii
<b>Need Only a Quick Start?</b> .....	xx

## Introduction

This *Access Security Guide* is intended for use with the following switches:

- HP Procurve Switch 4104GL
- HP Procurve Switch 4108GL

Together, these two devices are termed the *Series 4100GL switches*.

This guide describes how to use the command line interface (CLI), Menu interface, and web browser interface to configure, manage, and monitor switch operation. A troubleshooting chapter is also included.

For information on other product documentation for Series 4100 switches, refer to “Related Publications” on page xx.

The *Product Documentation CD-ROM* shipped with the switch includes a copy of this guide. You can also download a copy from the HP Procurve website. (See “Getting Documentation From the Web” on page xxi, below.)

## Conventions

This guide uses the following conventions for command syntax and displayed information.

## Command Syntax Statements

***Syntax:***   aaa port-access authenticator < *port-list* >  
                  [ control < authorized | auto | unauthorized > ]

- Vertical bars ( | ) separate alternative, mutually exclusive elements.
- Square brackets ( [ ] ) indicate optional elements.
- Braces ( < > ) enclose required elements.
- Braces within square brackets ( [ < > ] ) indicate a required element within an optional choice.
- Boldface indicates use of a CLI command, part of a CLI command syntax, or other displayed element in general text. For example:

                  “Use the **copy tftp** command to download the key from a TFTP server.”

- Italics indicate variables for which you must supply a value when executing the command. For example, in this command syntax, you must provide one or more port numbers:

***Syntax:*** aaa port-access authenticator < *port-list* >

# Simulating Display Output

Commands or command output positioned to simulate displays of switch information in a computer screen are printed in a monospace font.

## Command Prompts

In the default configuration, your Series 4100GL switch displays one of the following CLI prompts:

```
HP Procurve Switch 4104#  
HP Procurve Switch 4108#
```

To simplify recognition, this guide uses `HPswitch` to represent command prompts for all models. For example:

```
HPswitch#
```

(You can use the `hostname` command to change the text in the CLI prompt.)

## Screen Simulations

Figures containing simulated screen text and command output look like this:

```
HPswitch> show version  
Image stamp:   /sw/code/build/info  
               June 1 2002 13:43:13  
               G.05.02  
               139  
HPswitch>
```

**Figure 1. Example of a Figure Showing a Simulated Screen**

In some cases, brief command-output sequences appear without figure identification. For example:

```
HPswitch(config)# clear public-key  
HPswitch(config)# show ip client-public-key  
show_client_public_key: cannot stat keyfile
```

## Related Publications

**Product Notes and Software Update Information.** The *Read Me First* shipped with your switch provides software update information, product notes, and other information. A printed copy is shipped with your switch. For the latest version, refer to “Getting Documentation From the Web” on page xxi.

**Physical Installation and Initial Network Access.** Use the *Installation and Getting Started Guide* shipped with your switch to prepare for and perform the physical installation. This guide also steps you through connecting the switch to your network and assigning IP addressing, as well as describing the LED indications for correct operation and trouble analysis. A PDF version of this guide is also provided on the *Product Documentation CD-ROM* shipped with the switch. And you can download a copy from the HP Procurve website. (See “Getting Documentation From the Web” on page xxi.)

**Access Security.** Use the *Access Security Guide* to learn how to use and configure the following access security features available in the switch:

- Username and Password Security
- TACACS+ Authentication
- RADIUS Authentication and Accounting
- Secure Shell (SSH) Encryption
- Port-Based Access Control (802.1x)
- Port Security Using Authorized MAC Addresses
- Authorized IP Managers

HP provides a PDF version of this guide on the *Product Documentation CD-ROM* shipped with the switch. You can also download a copy from the HP Procurve website. (See “Getting Documentation From the Web” on page xxi.)

**Command Line Interface Reference Guide.** This guide, available in a PDF file on the HP Procurve website, provides a summary of the CLI commands generally available for HP Procurve switches. For the latest version, see “Getting Documentation From the Web” on page xxi.

**Release Notes.** Release notes are posted on the HP Procurve website and provide information on new software updates:

- New features and how to configure and use them
- Software management, including downloading software to the switch
- Software fixes addressed in current and previous releases

To view and download a copy of the latest release notes for your switch, see “Getting Documentation From the Web” on page xxi.

# Getting Documentation From the Web

1. Go to the HP Procurve website at <http://www.hp.com/go/hpprocurve>
2. Click on **technical support**.
3. Click on **manuals**.
4. Click on the product for which you want to view or download a manual.

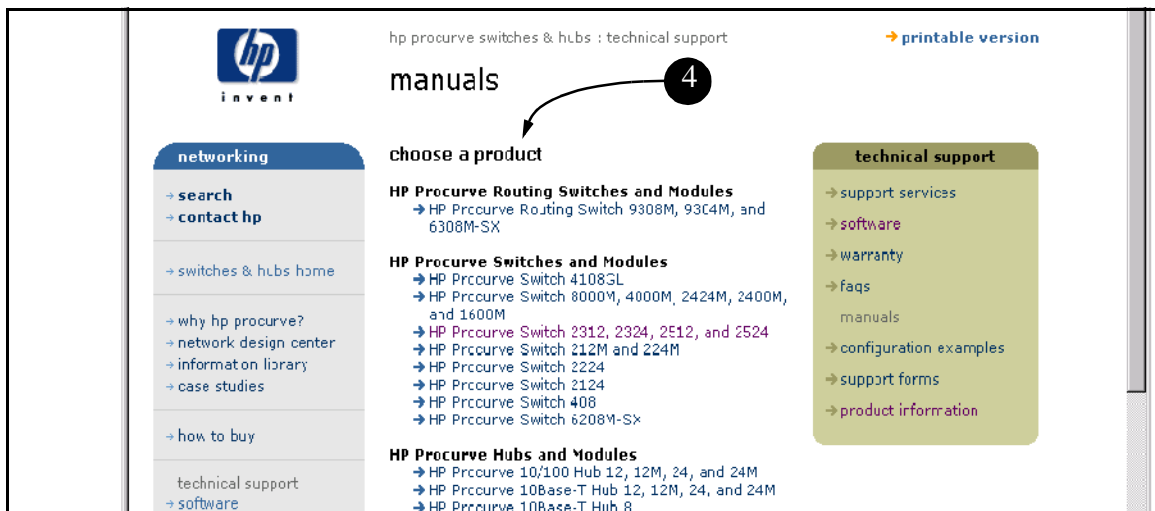
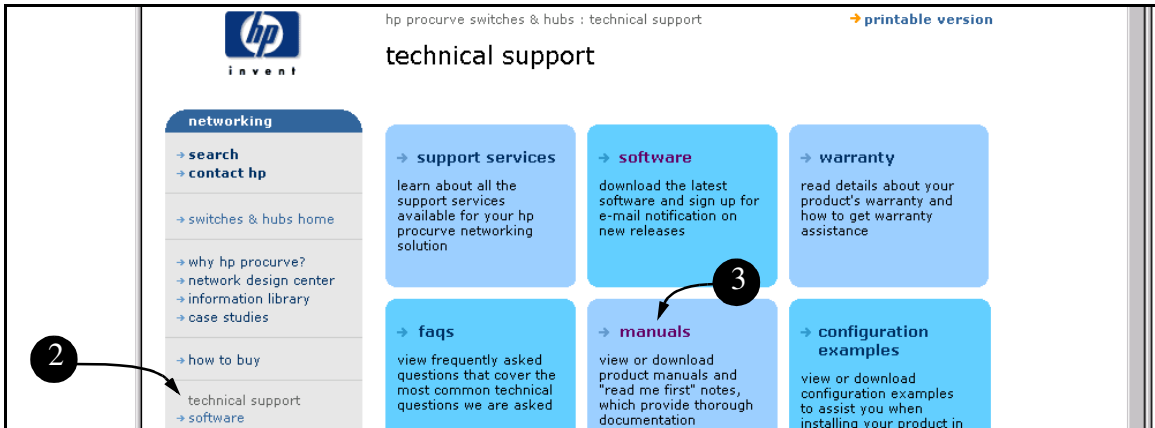

## Sources for More Information

- If you need information on specific parameters in the menu interface, refer to the online help provided in the interface. For example:

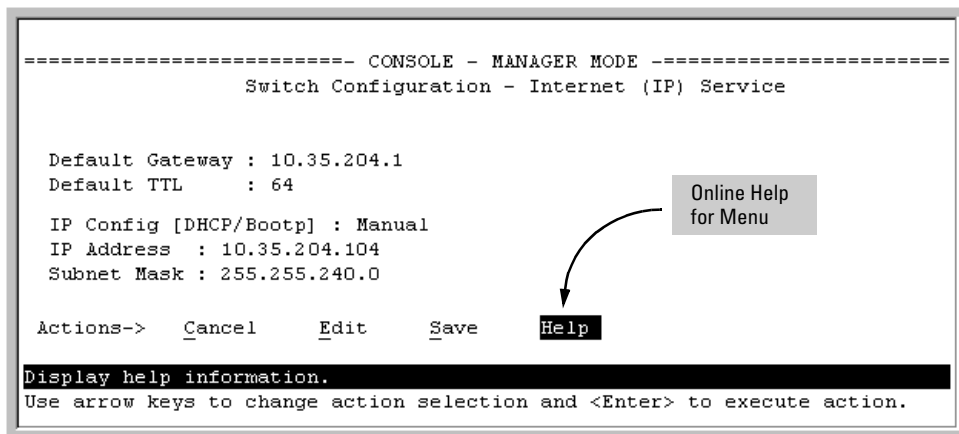

**Figure 2. Getting Help in the Menu Interface**

- If you need information on a specific command in the CLI, type the command name followed by “help”. For example:

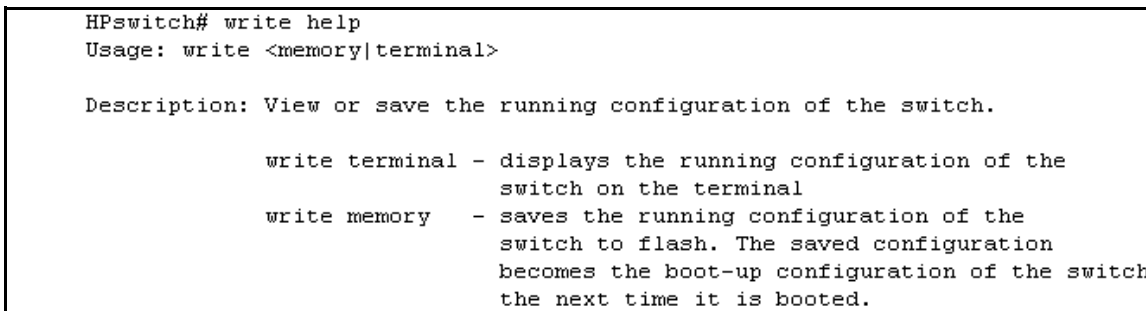

**Figure 3. Getting Help in the CLI**

- If you need information on specific features in the HP Web Browser Interface (hereafter referred to as the “web browser interface”), use the online help available for the web browser interface. For more information on web browser Help options, refer to “Online Help for the HP Web Browser Interface” on page 4-11.
- If you need further information on Hewlett-Packard switch technology, visit the HP Procurve website at:

<http://www.hp.com/go/hpprocurve>



## Need Only a Quick Start?

**IP Addressing.** If you just want to give the switch an IP address so that it can communicate on your network, or if you are not using VLANs, HP recommends that you use the Switch Setup screen to quickly configure IP addressing. To do so, do one of the following:

- Enter **setup** at the CLI Manager level prompt.  
HPswitch# setup
- In the Main Menu of the Menu interface, select  
**8. Run Setup**

For more on using the Switch Setup screen, see the *Installation and Getting Started Guide* you received with the switch.

## To Set Up and Install the Switch in Your Network

---

**Important!**

---

Use the *HP Procurve Series 4100 Installation and Getting Started Guide* (shipped with the switch) for the following:

- Notes, cautions, and warnings related to installing and using the switch and its related modules
- Instructions for physically installing the switch in your network
- Quickly assigning an IP address and subnet mask, set a Manager password, and (optionally) configure other basic features.
- Interpreting LED behavior.

**Getting Started**  
Need Only a Quick Start?

# Selecting a Management Interface

---

## Contents

<b>Overview</b> .....	1-2
<b>Understanding Management Interfaces</b> .....	1-2
<b>Advantages of Using the Menu Interface</b> .....	1-3
<b>Advantages of Using the CLI</b> .....	1-4
<b>Advantages of Using the HP Web Browser Interface</b> .....	1-5
<b>Advantages of Using HP TopTools for Hubs &amp; Switches</b> .....	1-6

## Overview

This chapter describes the following:

- Management interfaces for the Series 41008GL switches
  - Advantages of using each interface
- 

## Understanding Management Interfaces

Management interfaces enable you to reconfigure the switch and to monitor switch status and performance. The HP Series 41008GL switches offer the following interfaces:

- **Menu interface**—a menu-driven interface offering a subset of switch commands through the built-in VT-100/ANSI console—**page 1-3**
- **CLI**—a command line interface offering the full set of switch commands through the VT-100/ANSI console built into the switch—**page 1-4**
- **Web browser interface**—a switch interface offering status information and a subset of switch commands through a standard web browser (such as Netscape Navigator or Microsoft Internet Explorer)—**page 1-5**
- **HP TopTools for Hubs & Switches**—an easy-to-use, browser-based network management tool that works with HP proactive networking features built into managed HP hubs and switches

This manual describes how to use the menu interface (chapter 2), the CLI (chapter 3), the web browser interface (chapter 4), and how to use these interfaces to configure and monitor the switch.

For information on how to access the web browser interface Help, see “Online Help for the Web Browser Interface” on page 4-11.

To use HP TopTools for Hubs & Switches, refer to the *HP TopTools User's Guide* and the TopTools online help, which are available electronically with the TopTools software. (To get a copy of HP TopTools for Hubs & Switches software, see the *Read Me First* document shipped with your switch.)

---

---

## Advantages of Using the Menu Interface

```
===== CONSOLE - MANAGER MODE =====
                          Main Menu
1. Status and Counters...
2. Switch Configuration...
3. Console Passwords...
4. Event Log
5. Command Line (CLI)
6. Reboot Switch
7. Download OS
8. Run Setup
9. Stacking...
0. Logout

Provides the menu to display configuration, status, and counters.
To select menu item, press item number, or highlight item and press <Enter>.
```

**Figure 1-1. Example of the Console Interface Display**

- **Provides quick, easy management access** to a menu-driven subset of switch configuration and performance features:

- IP addressing
- VLANs and GVRP
- Port Security
- Port and Static Trunk Group
- Stack Management
- Spanning Tree
- System information
- Passwords
- SNMP communities
- Time protocols

The menu interface also provides access for:

- Setup screen
  - Event Log display
  - Switch and port status displays
  - Switch and port statistic and counter displays
  - Reboots
  - Software downloads
- **Offers out-of-band access** (through the RS-232 connection) to the switch, so network bottlenecks, crashes, lack of configured or correct IP address, and network downtime do not slow or prevent access
  - **Enables Telnet (in-band) access** to the menu functionality.
  - **Allows faster navigation**, avoiding delays that occur with slower display of graphical objects over a web browser interface.
  - **Provides more security**; configuration information and passwords are not seen on the network.

## Advantages of Using the CLI

HPswitch>	Operator Level
HPswitch#	Manager Level
HPswitch(config)#	Global Configuration Level
HPswitch(<context>)#	Context Configuration Levels (port, VLAN)

**Figure 1-2. Command Prompt Examples**

- Provides access to the complete set of the switch configuration, performance, and diagnostic features.
- Offers out-of-band access (through the RS-232 connection) or Telnet (in-band) access.
- Enables quick, detailed system configuration and management access to system operators and administrators experienced in command prompt interfaces.
- Provides help at each level for determining available options and variables.

### CLI Usage

- For information on how to use the CLI, refer to chapter 3. "Using the Command Line Interface (CLI)".
- To perform specific procedures (such as configuring IP addressing or VLANs), use the Contents listing at the front of the manual to locate the information you need.
- For monitoring and analyzing switch operation, refer to appendix B.
- For information on individual CLI commands, refer to the Index or to the online Help provided in the CLI interface.

## Advantages of Using the HP Web Browser Interface

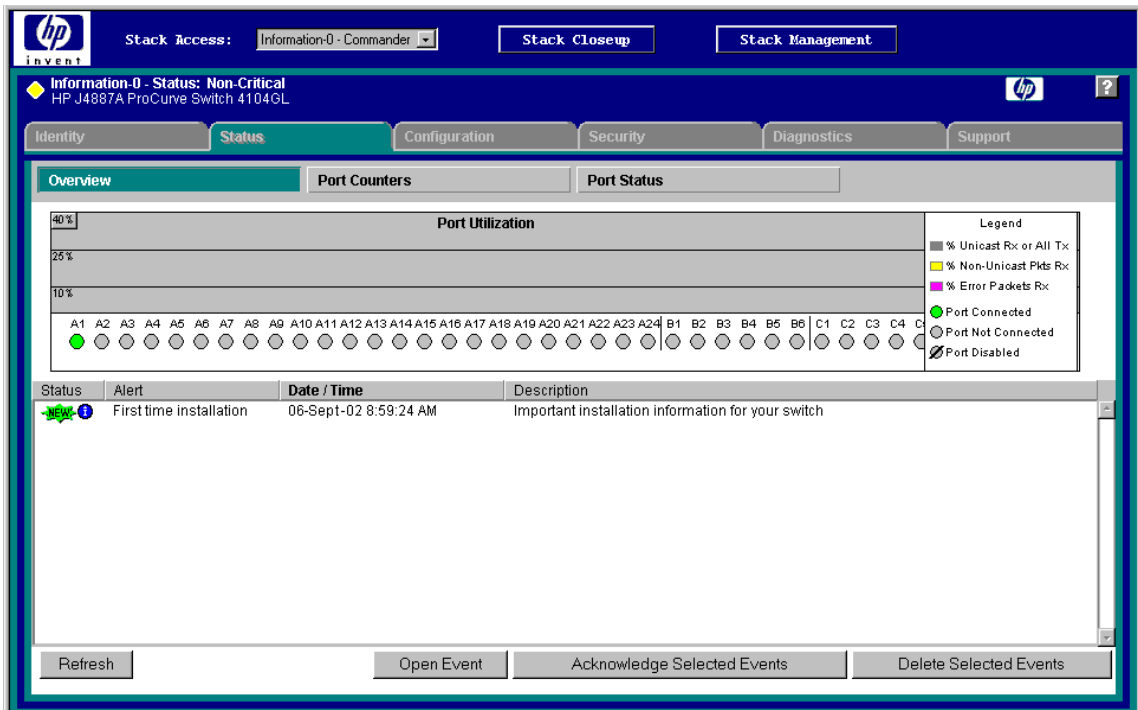
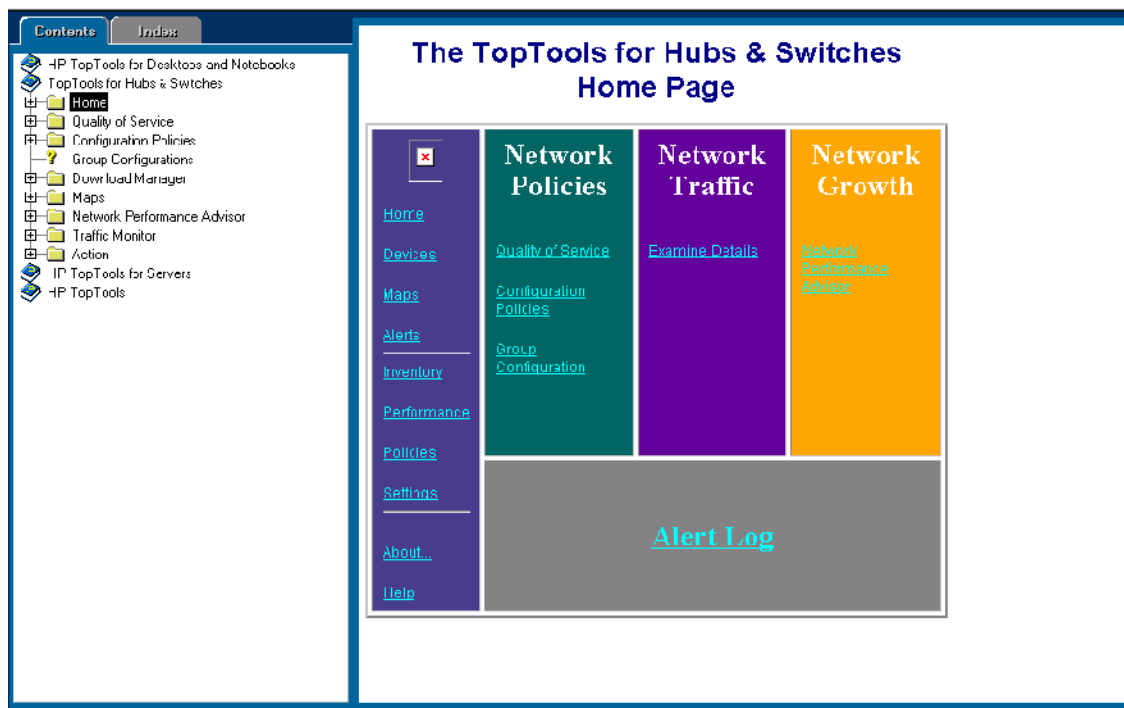

Figure 1-3. Example of the HP Web Browser Interface

- **Easy access** to the switch from anywhere on the network
- **Familiar browser interface**—locations of window objects consistent with commonly used browsers, uses mouse clicking for navigation, no terminal setup
- **Many features have all their fields in one screen** so you can view all values at once
- **More visual cues**, using colors, status bars, device icons, and other graphical objects instead of relying solely on alphanumeric values
- **Display of acceptable ranges of values available** in configuration list boxes

# Advantages of Using HP TopTools for Hubs & Switches

You can operate HP TopTools from a PC on the network to monitor traffic, manage your hubs and switches, and proactively recommend network changes to increase network uptime and optimize performance. Easy to install and use, HP TopTools for Hubs & Switches is the answer to your management challenges.



**Figure 1-4. Example of HP TopTools Home Page**



HP TopTools for Hubs & Switches enables greater control, uptime, and performance in your network:

- For networked devices
  - Enables fast installation of hubs and switches.
  - Enables you to proactively manage your network by using the Alert Log to quickly identify problems and suggest solutions, saving valuable time.
  - Notifies you when HP hubs use “self-healing” features to fix or limit common network problems.
  - Provides a list of discovered devices, with device type, connectivity status, the number of new or open alerts for each device, and the type of management for each device.
  - Provides graphical maps of your networked devices, from which you can access specific devices.
  - Identifies users by port and lets you assign easy-to-remember names to any network device.
  - Enables you to configure and monitor HP networked devices from your network management PC, including identity and status information, port counters, port on/off capability, sensitivity thresholds for traps, IP and security configuration, device configuration report, and other device features.
  - Enables policy-based management through the Quality of Service feature (QoS) to establish traffic priority policies for controlling and improving throughput across all the HP switches in your network that support this feature.
- For network traffic:
  - Watches the network for problems and displays real-time information about network status.
  - Shows traffic and “top talker” nodes on screen.
  - Uses traffic monitor diagrams to make bottlenecks easy to see.
  - Improves network reliability through real-time fault isolation.
  - Lets you see your entire network without having to put RMON probes on every segment (up to 1500 segments).
- For network growth:
  - Monitors, stores, and analyzes network traffic to determine where upgrades are needed.
  - Uses Network Performance Advisor for automatic traffic analysis and easy-to-understand reports that give clear, easy-to-follow plans for cost-effectively upgrading your network.

## **Selecting a Management Interface**

Advantages of Using HP TopTools for Hubs & Switches

# Using the Menu Interface

---

## Contents

<b>Overview</b> .....	2-2
<b>Starting and Ending a Menu Session</b> .....	2-3
How To Start a Menu Interface Session .....	2-4
How To End a Menu Session and Exit from the Console .....	2-5
<b>Main Menu Features</b> .....	2-7
<b>Screen Structure and Navigation</b> .....	2-9
<b>Rebooting the Switch</b> .....	2-12
<b>Menu Features List</b> .....	2-14
<b>Where To Go From Here</b> .....	2-15

## Overview

This chapter describes the following features:

- Overview of the Menu Interface (page 4-1)
- Starting and ending a Menu session (page 2-3)
- The Main Menu (page 2-7)
- Screen structure and navigation (page 2-9)
- Rebooting the switch (page 2-12)

The menu interface operates through the switch console to provide you with a subset of switch commands in an easy-to-use menu format enabling you to:

- Perform a "quick configuration" of basic parameters, such as the IP addressing needed to provide management access through your network
- Configure these features:
  - Manager and Operator passwords
  - System parameters
  - IP addressing
  - Time protocol
  - Ports
  - Trunk groups
  - A network monitoring port
  - Stack Management
  - Spanning Tree operation
  - SNMP community names
  - IP authorized managers
  - VLANs (Virtual LANs) and GVRP
- View status, counters, and Event Log information
- Update switch software
- Reboot the switch

For a detailed list of menu features, see the "Menu Features List" on page 2-14.

**Privilege Levels and Password Security.** HP strongly recommends that you configure a Manager password to help prevent unauthorized access to your network. A Manager password grants full read-write access to the switch. An Operator password, if configured, grants access to status and counter, Event Log, and the Operator level in the CLI. After you configure passwords on the switch and log off of the interface, access to the menu interface (and the CLI and web browser interface) will require entry of either the Manager or Operator password. (If the switch has only a Manager password, then someone without a password can still gain read-only access.)

---

**Note**

*If the switch has neither a Manager nor an Operator password, anyone having access to the console interface can operate the console with full manager privileges. Also, if you configure only an Operator password, entering the Operator password enables full manager privileges.*

---

For more information on passwords, see the chapter on local passwords in the Access Security Guide for your switch.

- The menu interface displays the current running-config parameter settings. You can use the menu interface to save configuration changes made in the CLI only if the CLI changes are in the running config when you save changes made in the menu interface. (For more on how switch memory manages configuration changes, see Chapter 5, “Switch Memory and Configuration”.)
- A configuration change made through any switch interface overwrites earlier changes made through any other interface.
- The Menu Interface and the CLI (Command Line Interface) both use the switch console. To enter the menu from the CLI, use the **menu** command. To enter the CLI from the Menu interface, select **Command Line (CLI)** option.)

---

## Starting and Ending a Menu Session

You can access the menu interface using any of the following:

- A direct serial connection to the switch’s console port, as described in the installation guide you received with the switch
- A Telnet connection to the switch console from a networked PC or the switch’s web browser interface. Telnet requires that an IP address and subnet mask compatible with your network have already been configured on the switch.
- The stack Commander, if the switch is a stack member

---

**Note**

This section assumes that either a terminal device is already configured and connected to the switch (see the *Installation and Getting Started Guide* shipped with your switch) or that you have already configured an IP address on the switch (required for Telnet access).

---

## How To Start a Menu Interface Session

In its factory default configuration, the switch console starts with the CLI prompt. To use the menu interface with Manager privileges, go to the Manager level prompt and enter the **menu** command.

1. Use one of these methods to connect to the switch:

- A PC terminal emulator or terminal
- Telnet

(You can also use the stack Commander if the switch is a stack member. See Chapter 14, “HP Procurve Stack Management”).

2. Do one of the following:

- If you are using Telnet, go to step 3.
- If you are using a PC terminal emulator or a terminal, press `[Enter]` one or more times until a prompt appears.

3. When the switch screen appears, do one of the following:

- If a password has been configured, the password prompt appears.

```
Password: _
```

Type the Manager password and press `[Enter]`. Entering the Manager password gives you manager-level access to the switch. (Entering the Operator password gives you operator-level access to the switch. Refer to the chapter on local manager and operator usernames and passwords in the *Access Security Guide* for your switch.)

- If no password has been configured, the CLI prompt appears. Go to the next step.

4. When the CLI prompt appears, display the Menu interface by entering the **menu** command. For example:

```
HPswitch# menu [Enter]
```

results in:

```
===== CONSOLE - MANAGER MODE =====  
Main Menu  
  
1. Status and Counters...  
2. Switch Configuration...  
3. Console Passwords...  
4. Event Log  
5. Command Line (CLI)  
6. Reboot Switch  
7. Download OS  
8. Run Setup  
9. Stacking...  
0. Logout  
  
Provides the menu to display configuration, status, and counters.  
To select menu item, press item number, or highlight item and press <Enter>.
```

**Figure 2-1. The Main Menu with Manager Privileges**

For a description of Main Menu features, see “Main Menu Features” on page 2-7.

---

**Note**

To configure the switch to start with the menu interface instead of the CLI, go to the Manager level prompt in the CLI, enter the **setup** command, and in the resulting display, change the **Logon Default** parameter to **Menu**. For more information, see the *Installation and Getting Started Guide* you received with the switch.

---

## How To End a Menu Session and Exit from the Console:

The method for ending a menu session and exiting from the console depends on whether, during the session, you made any changes to the switch configuration that require a switch reboot to activate. (Most changes via the menu interface need only a **Save**, and do not require a switch reboot.) Configuration changes needing a reboot are marked with an asterisk (\*) next to the configured item in the menu and also next to the **Switch Configuration** item in the Main Menu.

Asterisk indicates a configuration change that requires a reboot to activate.

```
===== CONSOLE - MANAGER MODE =====
Main Menu

1. Status and Counters...
*2. Switch Configuration...
3. Console Passwords...
4. Event Log
5. Command Line (CLI)
6. Reboot Switch
7. Download OS
8. Run Setup
9. Stacking...
0. Logout

Displays the menu for customizing the switch configuration.
To select menu item, press item number, or highlight item and press <Enter>.
(*Needs reboot to activate changes.)
```

**Figure 2-2. An Asterisk Indicates a Configuration Change Requiring a Reboot**

1. In the current session, if you have not made configuration changes that require a switch reboot to activate, return to the Main Menu and press **0** (zero) to log out. Then just exit from the terminal program, turn off the terminal, or quit the Telnet session.
2. If you *have* made configuration changes that require a switch reboot—that is, if an asterisk (\*) appears next to a configured item or next to **Switch Configuration** in the Main Menu:

- a. Return to the Main Menu.
- b. Press **6** to select **Reboot Switch** and follow the instructions on the reboot screen.

Rebooting the switch terminates the menu session, and, if you are using Telnet, disconnects the Telnet session.

(See “Rebooting To Activate Configuration Changes” on page 2-13.)

3. Exit from the terminal program, turn off the terminal, or close the Telnet application program.



---

## Main Menu Features

```
===== CONSOLE - MANAGER MODE =====
                          Main Menu

1. Status and Counters...
2. Switch Configuration...
3. Console Passwords...
4. Event Log
5. Command Line (CLI)
6. Reboot Switch
7. Download OS
8. Run Setup
9. Stacking...
0. Logout

Provides the menu to display configuration, status, and counters.
To select menu item, press item number, or highlight item and press <Enter>.
```

**Figure 2-3. The Main Menu View with Manager Privileges**

The Main Menu gives you access to these Menu interface features:

- **Status and Counters:** Provides access to display screens showing switch information, port status and counters, port and VLAN address tables, and spanning tree information. (See Chapter B, “Monitoring and Analyzing Switch Operation”.)
- **Switch Configuration:** Provides access to configuration screens for displaying and changing the current configuration settings. (See the Contents listing at the front of this manual.) For a listing of features and parameters configurable through the menu interface, see the “Menu Features List” on page 2-14 .
- **Console Passwords:** Provides access to the screen used to set or change Manager-level and Operator-level passwords, and to delete Manager and Operator password protection. (See the local password chapter in the Access Security Guide shipped with your switch.)
- **Event Log:** Enables you to read progress and error messages that are useful for checking and troubleshooting switch operation. (See “Using the Event Log To Identify Problem Sources” on page C-21.)

- **Command Line (CLI):** Selects the Command Line Interface at the same level (Manager or Operator) that you are accessing in the Menu interface. (See chapter 3, "Using the Command Line Interface (CLI)".)
- **Reboot Switch:** Performs a "warm" reboot of the switch, which clears most temporary error conditions, resets the network activity counters to zero, and resets the system up-time to zero. A reboot is required to activate a change in the VLAN Support parameter. (See "Rebooting from the Menu Interface" on page 5-10.)
- **Download OS:** Enables you to download a new software version to the switch. (See Appendix A, "File Transfers".)
- **Run Setup:** Displays the Switch Setup screen for quickly configuring basic switch parameters such as IP addressing, default gateway, logon default interface, spanning tree, and others. (See the *Installation and Getting Started* guide shipped with your switch.)
- **Stacking:** Enables you to use a single IP address and standard network cabling to manage a group of up to 16 switches in the same subnet (broadcast domain). See Chapter 14, "HP Procurve Stack Management".
- **Logout:** Closes the Menu interface and console session, and disconnects Telnet access to the switch. (See "How to End a Menu Session and Exit from the Console" on page 2-5.)

## Screen Structure and Navigation

Menu interface screens include these three elements:

- Parameter fields and/or read-only information such as statistics
- Navigation and configuration actions, such as Save, Edit, and Cancel
- Help line to describe navigation options, individual parameters, and read-only data

For example, in the following System Information screen:

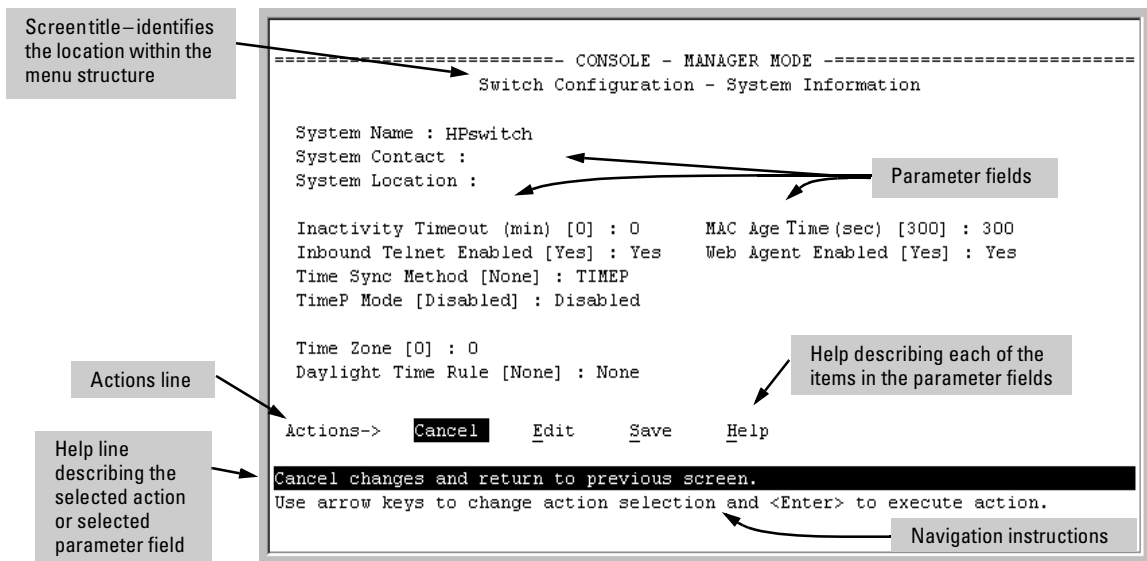

**Figure 2-4. Elements of the Screen Structure**

**“Forms” Design.** The configuration screens, in particular, operate similarly to a number of PC applications that use forms for data entry. When you first enter these screens, you see the current configuration for the item you have selected. To change the configuration, the basic operation is to:

1. Press **[E]** to select the **Edit** action.
2. Navigate through the screen making all the necessary configuration changes. (See Table 4-1 on the next page.)
3. Press **[Enter]** to return to the **Actions** line. From there you can save the configuration changes or cancel the changes. Cancel returns the configuration to the values you saw when you first entered the screen.

**Table 2-1. How To Navigate in the Menu Interface**

Task:	Actions:
Execute an action from the “Actions →” list at the bottom of the screen:	<p>Use either of the following methods:</p> <ul style="list-style-type: none"> <li>• Use the arrow keys ( ← , or → ) to highlight the action you want to execute, then press <b>[Enter]</b>.</li> <li>• Press the key corresponding to the capital letter in the action name. For example, in a configuration menu, press <b>[E]</b> to select Edit and begin editing parameter values.</li> </ul>
Reconfigure (edit) a parameter setting or a field:	<ol style="list-style-type: none"> <li>1. Select a configuration item, such as <b>System Name</b>. (See figure 4.)</li> <li>2. Press <b>[E]</b> (for <b>Edit</b> on the Actions line).</li> <li>3. Use <b>[Tab]</b> or the arrow keys ( ← , → , ↑ , or ↓ ) to highlight the item or field.</li> <li>4. Do one of the following: <ul style="list-style-type: none"> <li>– If the parameter has preconfigured values, either use the Space bar to select a new option or type the first part of your selection and the rest of the selection appears automatically. (The help line instructs you to “Select” a value.)</li> <li>– If there are no preconfigured values, type in a value (the Help line instructs you to “Enter” a value).</li> </ul> </li> <li>5. If you want to change another parameter value, return to step 3.</li> <li>6. If you are finished editing parameters in the displayed screen, press <b>[Enter]</b> to return to the Actions line and do one of the following: <ul style="list-style-type: none"> <li>– To save and activate configuration changes, press <b>[S]</b> (for the <b>Save</b> action). This saves the changes in the startup configuration and also implements the change in the currently running configuration. (See Chapter 5, “Switch Memory and Configuration”.)</li> <li>– To exit from the screen without saving any changes that you have made (or if you have not made changes), press <b>[C]</b> (for the <b>Cancel</b> action).</li> </ul> <p><b>Note:</b> In the menu interface, executing Save activates most parameter changes and saves them in the startup configuration (or flash) memory, and it is therefore not necessary to reboot the switch after making these changes. But if an asterisk appears next to any menu item you reconfigure, the switch will not activate or save the change for that item until you reboot the switch. In this case, rebooting should be done after you have made all desired changes and then returned to the Main Menu.</p> </li> <li>7. When you finish editing parameters, return to the Main Menu.</li> <li>8. If necessary, reboot the switch by highlighting Reboot Switch in the Main Menu and pressing <b>[Enter]</b>. (See the <b>Note</b>, above.)</li> </ol>
Exit from a read-only screen.	Press <b>[B]</b> (for the <b>Back</b> action).

**To get Help on individual parameter descriptions.** In most screens there is a **Help** option in the **Actions** line. Whenever any of the items in the **Actions** line is highlighted, press **[H]**, and a separate help screen is displayed. For example:

----- CONSOLE - MANAGER MODE -----  
Switch Configuration - System Information

System Name : HPswitch  
System Contact :  
System Location :

Inactivity Timeout (min) [0] : 0      MAC Age Time (sec) [300] : 300  
Inbound Telnet Enabled [Yes] : Yes      Web Agent Enabled [Yes] : Yes  
Time Sync Method [None] : TIMEP  
TimeP Mode [Disabled] : Disabled

Time Zone [0] : 0  
Daylight Time Rule [None] : None

Actions->    **Cancel**      Edit      Save      Help

**Cancel changes and return to previous screen.**  
Use arrow keys to change action selection and <Enter> to execute action.

Callout 1: Highlight on any item in the Actions line indicates that the Actions line is active.

Callout 2: The Help line provides a brief descriptor of the highlighted Action item or parameter.

Callout 3: Pressing **[H]** or highlighting **Help** and pressing **[Enter]** displays Help for the parameters listed in the upper part of the screen

**Figure 2-5. Example Showing How To Display Help**

**To get Help on the actions or data fields in each screen:** Use the arrow keys (**[←]**, **[→]**, **[↑]**, or **[↓]**) to select an action or data field. The help line under the **Actions** items describes the currently selected action or data field.

**For guidance on how to navigate in a screen:** See the instructions provided at the bottom of the screen, or refer to “Screen Structure and Navigation” on page 2-9.)

## Rebooting the Switch

Rebooting the switch from the menu interface

- Terminates all current sessions and performs a reset of the operating system
- Activates any menu interface configuration changes that require a reboot
- Resets statistical counters to zero

(Note that statistical counters can be reset to zero without rebooting the switch.)

To Reboot the switch, use the **Reboot Switch** option in the Main Menu. (Note that the Reboot Switch option is not available if you log on in Operator mode; that is, if you enter an Operator password instead of a manager password at the password prompt.)

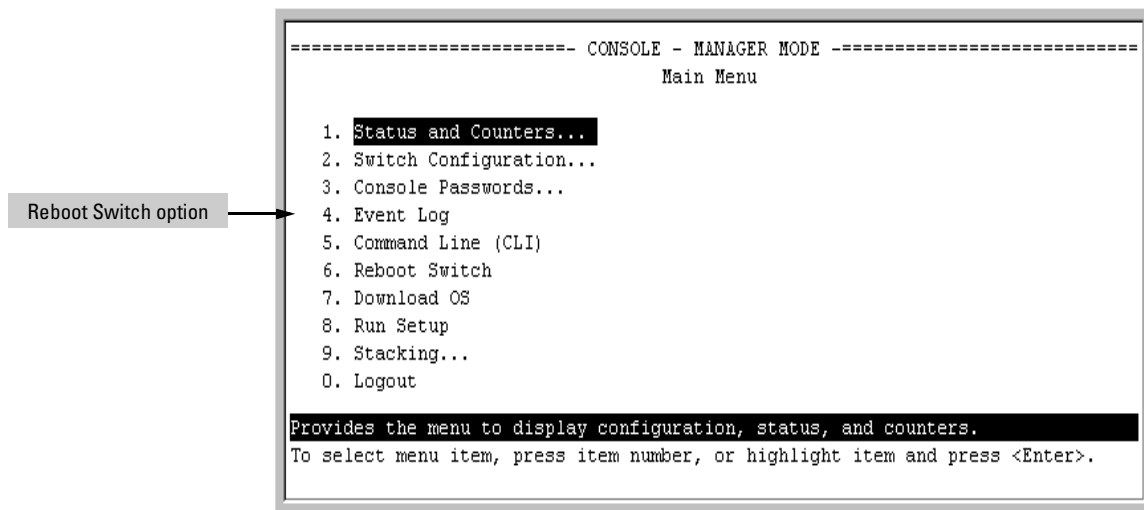

Figure 2-6. The Reboot Switch Option in the Main Menu

**Rebooting To Activate Configuration Changes.** Configuration changes for most parameters in the menu interface become effective as soon as you save them. However, you must reboot the switch in order to implement a change in the **Maximum VLANs to support parameter**. (To access this parameter, go to the Main Menu and select:

## 2. Switch Configuration

### 8. VLAN Menu

#### 1. VLAN Support.)

If you make configuration changes in the menu interface that require a reboot, the switch displays an asterisk (\*) next to the menu item in which the change has been made. For example, if you change and save the value for the **Maximum VLANs to support parameter**, an asterisk appears next to the **VLAN Support** entry in the VLAN Menu screen, and also next to the the **Switch Configuration ...** entry in the Main Menu, as shown in figure 4-6:

Asterisk indicates a configuration change that requires a reboot in order to take effect.

Reminder to reboot the switch to activate configuration changes.

```

===== CONSOLE - MANAGER MODE =====
                          Switch Configuration Menu

1. System Information
2. Port/Trunk Settings
3. Network Monitoring Port
4. Spanning Tree Operation
5. IP Configuration
6. SNMP Community Names
7. IP Authorized Managers
*8. VLAN Menu...
0. Return to Main Menu...

Displays the menu to activate and configure, or deactivate VLAN support.
To select menu item, press item number, or highlight item and press <Enter>.
(*Needs reboot to activate changes.)
        
```

**Figure 2-7. Indication of a Configuration Change Requiring a Reboot**

To activate changes indicated by the asterisk, go to the Main Menu and select the **Reboot Switch** option.

---

### Note

Executing the **write memory** command in the CLI does not affect pending configuration changes indicated by an asterisk in the menu interface. That is, only a reboot from the menu interface or a **boot** or **reload** command from the CLI will activate a pending configuration change indicated by an asterisk.

---

## Menu Features List

### Status and Counters

- General System Information
- Switch Management Address Information
- Port Status
- Port Counters
- Address Table
- Port Address Table
- Spanning Tree Information

### Switch Configuration

- System Information
- Port/Trunk Settings
- Network Monitoring Port
- Spanning Tree Operation
- IP Configuration
- SNMP Community Names
- IP authorized Managers
- VLAN Menu

### Console Passwords

### Event Log

### Command Line (CLI)

### Reboot Switch

### Download OS

### Run Setup

### Stacking

- Stacking Status (This Switch)
- Stacking Status (All)
- Stack Configuration
- Stack Management (*Available in Stack Commander Only*)
- Stack Access (*Available in Stack Commander Only*)

### Logout



## Where To Go From Here

This chapter provides an overview of the menu interface and how to use it. The following table indicates where to turn for detailed information on how to use the individual features available through the menu interface.

Option:	Turn to:
To use the Run Setup option	Refer to the <i>Installation and Getting Started Guide</i> shipped with the switch.
To use the HP Procurve Stack Manager	Chapter 14, "HP Procurve Stack Management"
To view and monitor switch status and counters	Appendix B, "Monitoring and Analyzing Switch Operation"
To learn how to configure and use passwords and other security features	Refer to the <i>Access Security Guide</i> for your switch.
To learn how to use the Event Log	"Using the Event Log To Identify Problem Sources" on page C-21
To learn how the CLI operates	Chapter 3, "Using the Command Line Interface (CLI)"
To download software (the OS)	Appendix A, "File Transfers"
For a description of how switch memory handles configuration changes	"Switch Memory and Configuration" on page 5-1
For information on other switch features and how to configure them	See the Table of Contents at the front of this manual.

---

**Using the Menu Interface**  
Where To Go From Here

# Using the Command Line Interface (CLI)

---

## Contents

<b>Overview</b> .....	3-2
<b>Accessing the CLI</b> .....	3-2
<b>Using the CLI</b> .....	3-2
Privilege Levels at Logon .....	3-3
Privilege Level Operation .....	3-4
Operator Privileges .....	3-4
Manager Privileges .....	3-5
How To Move Between Levels .....	3-7
Listing Commands and Command Options .....	3-8
Listing Commands Available at Any Privilege Level .....	3-8
Command Option Displays .....	3-10
Displaying CLI "Help" .....	3-11
Configuration Commands and the Context Configuration Modes ..	3-13
<b>CLI Control and Editing</b> .....	3-16

## Overview

The CLI is a text-based command interface for configuring and monitoring the switch. The CLI gives you access to the switch's full set of commands while providing the same password protection that is used in the web browser interface and the menu interface.

---

## Accessing the CLI

Like the menu interface, the CLI is accessed through the switch console, and, in the switch's factory default state, is the default interface when you start a console session. You can access the console out-of-band by directly connecting a terminal device to the switch, or in-band by using Telnet either from a terminal device or through the web browser interface.

Also, if you are using the menu interface, you can access the CLI by selecting the **Command Line (CLI)** option in the Main Menu.

---

## Using the CLI

The CLI offers these privilege levels to help protect the switch from unauthorized access:

1. Operator
2. Manager
3. Global Configuration
4. Context Configuration

---

### Note

CLI commands are not case-sensitive.

When you use the CLI to make a configuration change, the switch writes the change to the Running-Config file in volatile memory. This allows you to test your configuration changes before making them permanent. To make changes permanent, you must use the **write memory** command to save them to the

---

Startup Config file in non-volatile memory. If you reboot the switch without first using **write memory**, all changes made since the last reboot or **write memory** (whichever is later) will be lost. For more on switch memory and saving configuration changes, see Chapter 5, “Switch Memory and Configuration”.

## Privilege Levels at Logon

Privilege levels control the type of access to the CLI. To implement this control, you must set at least a Manager password. *Without a Manager password configured, anyone having serial port, Telnet, or web browser access to the switch can reach all CLI levels.* (For more on setting passwords, refer to the local manager and operator password chapter in the *Access Security Guide* for your switch.)

When you use the CLI to log on to the switch, and passwords are set, you will be prompted to enter a password. For example:

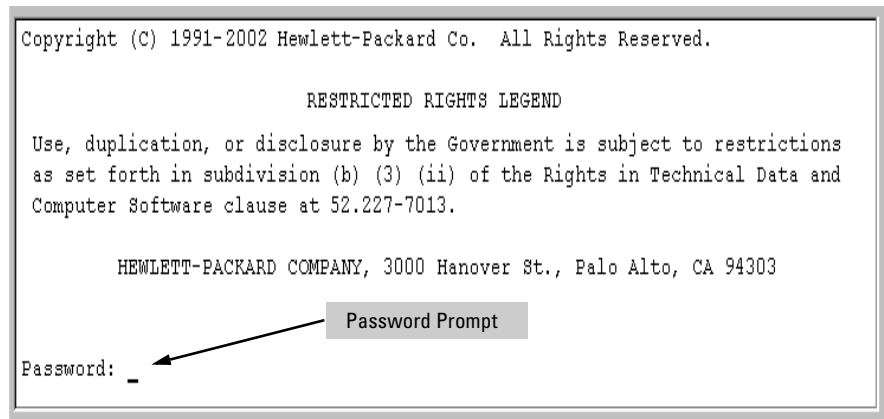

```
Copyright (C) 1991-2002 Hewlett-Packard Co. All Rights Reserved.  
  
RESTRICTED RIGHTS LEGEND  
  
Use, duplication, or disclosure by the Government is subject to restrictions  
as set forth in subdivision (b) (3) (ii) of the Rights in Technical Data and  
Computer Software clause at 52.227-7013.  
  
HEWLETT-PACKARD COMPANY, 3000 Hanover St., Palo Alto, CA 94303  
  
Password: _
```

An arrow points from a grey box labeled "Password Prompt" to the "Password: \_" line.

**Figure 3-1. Example of CLI Log-On Screen with Password(s) Set**

In the above case, you will enter the CLI at the level corresponding to the password you provide (operator or manager).

If no passwords are set when you log onto the CLI, you will enter at the Manager level. For example:

```
HPswitch# _
```

---

**Caution**

HP strongly recommends that you configure a Manager password. If a Manager password is not configured, then the Manager level is not password-protected, and anyone having in-band or out-of-band access to the switch may be able to reach the Manager level and compromise switch and network security. Note that configuring only an Operator password *does not* prevent access to the Manager level by intruders who have the Operator password.

Pressing the Clear button on the front of the switch removes password protection. *For this reason, it is recommended that you protect the switch from physical access by unauthorized persons.* If you are concerned about switch security and operation, you should install the switch in a secure location, such as a locked wiring closet.

---

## Privilege Level Operation

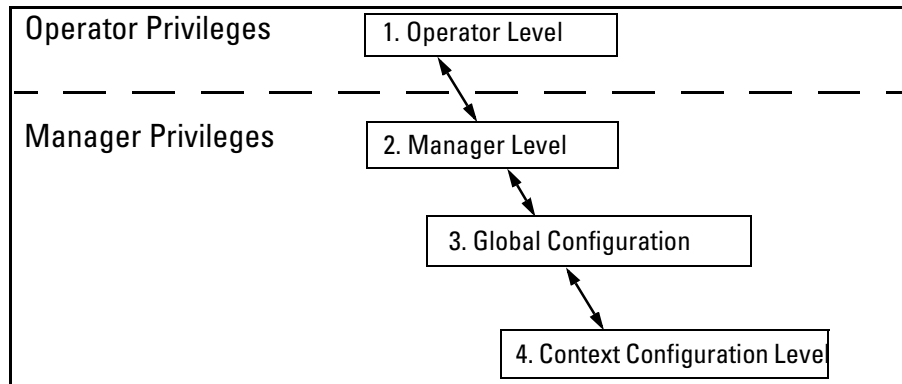

**Figure 3-2. Access Sequence for Privilege Levels**

### Operator Privileges

At the Operator level you can examine the current configuration and move between interfaces without being able to change the configuration. A ">" character delimits the Operator-level prompt. For example:

```
HPswitch> _ (Example of the Operator prompt.)
```

When using **enable** to move to the Manager level, the switch prompts you for the Manager password if one has already been configured.

## Manager Privileges

Manager privileges give you three additional levels of access: Manager, Global Configuration, and Context Configuration. (See figure .) A "#" character delimits any Manager prompt. For example:

```
HPswitch#_          (Example of the Manager prompt.)
```

- **Manager level:** Provides all Operator level privileges plus the ability to perform system-level actions that do not require saving changes to the system configuration file. The prompt for the Manager level contains only the system name and the "#" delimiter, as shown above. To select this level, enter the **enable** command at the Operator level prompt and enter the Manager password, when prompted. For example:

```
HPswitch> enable   (Enter enable at the Operator prompt.)  
HPswitch# _       (The Manager prompt.)
```

- **Global Configuration level:** Provides all Operator and Manager level privileges, and enables you to make configuration changes to any of the switch's software features. The prompt for the Global Configuration level includes the system name and "(config)". To select this level, enter the **config** command at the Manager prompt. For example:

```
HPswitch# _        (Enter config at the Manager prompt.)  
HPswitch(config)#_(The Global Config prompt.)
```

- **Context Configuration level:** Provides all Operator and Manager privileges, and enables you to make configuration changes in a specific context, such as one or more ports or a VLAN. The prompt for the Context Configuration level includes the system name and the selected context. For example:

```
HPswitch(eth-1)#  
HPswitch(vlan-10)#
```

The Context level is useful, for example, if you want to execute several commands directed at the same port or VLAN, or if you want to shorten the command strings for a specific context area. To select this level, enter the specific context at the Global Configuration level prompt. For example, to select the context level for an existing VLAN with the VLAN ID of 10, you would enter the following command and see the indicated result:

```
HPswitch(config)# vlan 10  
HPswitch(vlan-10)#
```

**Changing Interfaces.** If you change from the CLI to the menu interface, or the reverse, you will remain at the same privilege level. For example, entering the menu command from the Operator level of the CLI takes you to the Operator privilege level in the menu interface.

**Table 3-1. Privilege Level Hierarchy**

Privilege Level	Example of Prompt and Permitted Operations		
<b>Operator Privilege</b>			
Operator Level	HPswitch>	show <command> setup	View status and configuration information.
		ping <argument> link-test <argument>	Perform connectivity tests.
		enable	Move from the Operator level to the Manager level.
		menu	Move from the CLI interface to the menu interface.
		logout	Exit from the CLI interface and terminate the console session.
		exit	Terminate the current session (same as logout).
<b>Manager Privilege</b>			
Manager Level	HPswitch#		Perform system-level actions such as system control, monitoring, and diagnostic commands, plus any of the Operator-level commands. For a list of available commands, enter ? at the prompt.
Global Configuration Level	HPswitch(config) #		Execute configuration commands, plus all Operator and Manager commands. For a list of available commands, enter ? at the prompt.
Context Configuration Level	HPswitch(eth-5) # HPswitch(vlan-100) #		Execute context-specific configuration commands, such as a particular VLAN or switch port. This is useful for shortening the command strings you type, and for entering a series of commands for the same context. For a list of available commands, enter ? at the prompt.



## How To Move Between Levels

Change in Levels	Example of Prompt , Command, and Result
Operator level <i>to</i> Manager level	<pre>HPswitch&gt; enable Password: _ HPswitch# _</pre> <p>After you enter <b>enable</b>, the Password prompt appears. After you enter the Manager password, the system prompt appears with the # symbol:</p>
Manager level <i>to</i> Global configuration level	<pre>HPswitch# config HPswitch(config)#</pre>
Global configuration level <i>to a</i> Context configuration level	<pre>HPswitch(config)# vlan 10 HPswitch(vlan-10)#</pre>
Context configuration level <i>to another</i> Context configuration level	<pre>HPswitch(vlan-10)# interface e 3 HPswitch(int-3)#</pre> <p>The CLI accepts "e" as the abbreviated form of "ethernet".</p>
Move from any level to the preceding level	<pre>HPswitch(int-3)# exit HPswitch(config)# exit HPswitch# exit HPswitch&gt;</pre>
Move from any level to the Manager level	<pre>HPswitch(int-3)# end HPswitch# -or- HPswitch(config)# end HPswitch#</pre>

**Moving Between the CLI and the Menu Interface.** When moving between interfaces, the switch retains the current privilege level (Manager or Operator). That is, if you are at the Operator level in the menu and select the **Command Line Interface (CLI)** option from the Main Menu, the CLI prompt appears at the Operator level.

**Changing Parameter Settings.** Regardless of which interface is used (CLI, menu interface, or web browser interface), the most recently configured version of a parameter setting overrides any earlier settings for that parameter. For example, if you use the menu interface to configure an IP address of "X"

for VLAN 1 and later use the CLI to configure a different IP address of "Y" for VLAN 1, then "Y" replaces "X" as the IP address for VLAN 1 in the running-config file. If you subsequently execute **write memory** in the CLI, then the switch also stores "Y" as the IP address for VLAN 1 in the startup-config file. (For more on the startup-config and running config files, see Chapter 5, "Switch Memory and Configuration".)

## Listing Commands and Command Options

At any privilege level you can:

- List all of the commands available at that level
- List the options for a specific command

### Listing Commands Available at Any Privilege Level

At a given privilege level you can list and execute the commands that level offers, plus all of the commands available at preceding levels. For example, at the Operator level, you can list and execute only the Operator level commands. However, at the Manager level, you can list and execute the commands available at both the Operator and Manager levels.

**Type "?" To List Available Commands.** 1. Typing the ? symbol lists the commands you can execute at the current privilege level. For example, typing ? at the Operator level produces this listing:

```
HPswitch > ?
  enable
  exit
  link-test
  logout
  menu
  ping
  show
  setup
HPswitch >
```

**Figure 3-3. Example of the Operator Level Command Listing**

Typing ? at the Manager level produces this listing:

```

HPswitch#

boot          Reboot the device.
clear         Clear table/statistics or authorized client public keys
configure    Enter the Configuration context.
copy         Copy datafiles to/from the switch.
end          Return to the Manager Exec context.
erase startup-c... Erase configuration file stored in flash.
getmib       Retrieve and display the value of the MIB objects
            specified.
kill         Kill all other active console, telnet, or ssh sessions.
log          Display log events.
page        Toggle paging mode.
print        Execute a command and redirect its output to the device
            channel for current session.
redo         Re-execute a command from history.
reload       Warm reboot of the switch.
repeat       Repeat execution of a previous command.
setmib       Set the value of a MIB object.
setup        Enter the 'Switch Setup' screen for basic switch
            configuration.
telnet       Initiate an outbound telnet session to another network
            device.

-- MORE --, next page: Space, next line: Enter, quit: Control-C

```

When -- MORE -- appears, use the Space bar or **Return** to list additional commands.

**Figure 3-4. Example of the Manager-Level Command Listing**

When **-- MORE --** appears, there are more commands in the listing. To list the next screenfull of commands, press the Space bar. To list the remaining commands one-by-one, repeatedly press **Enter**.

Typing ? at the Global Configuration level or the Context Configuration level produces similar results.

**Use **Tab** To Search for or Complete a Command Word.** You can use **Tab** to help you find CLI commands or to quickly complete the current word in a command. To do so, type one or more consecutive characters in a command and then press **Tab** (with no spaces allowed). For example, at the Global Configuration level, if you press **Tab** immediately after typing "t", the CLI displays the available command options that begin with "t". For example:

```

HPswitch(config)# tTab
telnet-server
time
trunk
telnet
terminal
HPswitch(config)# t

```

As mentioned above, if you type part of a command word and press `[Tab]`, the CLI completes the current word (if you have typed enough of the word for the CLI to distinguish it from other possibilities), including hyphenated extensions. For example:

```
HPswitch(config)# port[Tab]
HPswitch(config)# port-security _
```

Pressing `[Tab]` after a completed command word lists the further options for that command.

```
HPswitch(config)# stack [Tab]
  commander <commander-str>
  join <mac-addr>
  auto-join
  transmission-interval <integer>
  <cr>
HPswitch(config)# stack
```

## Command Option Displays

**Conventions for Command Option Displays.** When you use the CLI to list options for a particular command, you will see one or more of the following conventions to help you interpret the command data:

- Braces ( < > ) indicate a required choice.
- Square brackets ( [ ] ) indicate optional elements.
- Vertical bars ( | ) separate alternative, mutually exclusive options in a command.

**Listing Command Options.** You can use the CLI to remind you of the options available for a command by entering command keywords followed by **?**. For example, suppose you want to see the command options for configuring port C5:

```
HPswitch(config)#(console ? )
terminal          Set type of terminal being used (default is vt100).
screen-refresh    Set default number of seconds before screen is refreshed
                  on the repeat command.
events           Set level of the events displayed in the device's Events
                  Log.
baud-rate         Set the data transmission speed for the device connect
                  sessions initiated through
flow-control      Set the Flow Control Method
inactivity-timer  Set the number of minutes of no activity detected on the
                  Console port before the switch terminates a
                  communication session.
```

**Figure 3-5. Example of How To List the Options for a Specific Command**

## Displaying CLI "Help"

CLI Help provides two types of context-sensitive information:

- Command list with a brief summary of each command's purpose
- Detailed information on how to use individual commands

**Displaying Command-List Help.** You can display a listing of command Help summaries for all commands available at the current privilege level. That is, when you are at the Operator level, you can display the Help summaries only for Operator-Level commands. At the Manager level, you can display the Help summaries for both the Operator and Manager levels, and so on.

**Syntax:** help

For example, to list the Operator-Level commands with their purposes:

```
HPswitch> help
  enable          Enter Manager Exec level
  exit            Return to previous command level or logout if at first
                 level.
  link-test       Test the connection to a MAC address on the LAN.
  logout          Terminate this console/telnet session.
  menu            Go to the menu system.
  ping            Send IP Ping requests to a device on the network.
  show            Display configuration data.
```

**Figure 3-6. Example of Context-Sensitive Command-List Help**

**Displaying Help for an Individual Command.** You can display Help for any command that is available at the current context level by entering enough of the command string to identify the command, along with help.

**Syntax:** <command string> help

For example, to list the Help for the **interface** command in the Global Configuration privilege level:

```
HPswitch(config)# interface help
Usage: [no] interface [ethernet] PORT-LIST [...]

Description: Enter the Interface Configuration Level, or execute one
command for that level. Without optional parameters
specified, the 'interface' command changes the context to
the Interface Configuration Context Level for execution of
configuration changes to the port or ports in the PORT-LIST.
The 'interface [ethernet] PORT-LIST' can be followed by any
command from the Interface Configuration Context Level in the
same command line. In this case the context level is not
changed, but the command is also executed for the port or ports
in the PORT-LIST. Use 'interface [ethernet] PORT-LIST ?'
to get a list of all valid commands.
```

**Figure 3-7. Example of How To Display Help for a Specific Command**

A similar action lists the Help showing additional parameter options for a given command. The following example illustrates how to list the Help for an interface command acting on a specific port:

```

HPswitch(config)# interface e c5 help
flow-control      Enable/disable flow control on the port.
speed-duplex      Define mode of operation for the port.
bcast-limit       Set a broadcast traffic percentage limit.
unknown-vlans     Define what the port will do when it encounters GVRP
                  packet requesting it to join a VLAN.
enable            Enable port.
disable           Disable port.
lacp              Define whether LACP is enabled on the port, and whether it
                  is in active or passive mode when enabled.
monitor           Define that the port is to be monitored.

```

**Figure 3-8. Example of Help for a Specific Instance of a Command**

Note that trying to list the help for an individual command from a privilege level that does not include that command results in an error message. For example, trying to list the help for the **interface** command while at the global configuration level produces this result:

```

HPswitch# interface help
Invalid input: interface

```

## Configuration Commands and the Context Configuration Modes

You can execute any configuration command in the global configuration mode or in selected context modes. However, using a context mode enables you to execute context-specific commands faster, with shorter command strings.

The Switch 4108GL offers interface (port or trunk group) and VLAN context configuration modes:

**Port or Trunk-Group Context .** Includes port- or trunk-specific commands that apply only to the selected port(s) or trunk group, plus the global configuration, Manager, and Operator commands. The prompt for this mode includes the identity of the selected port(s):

```

HPswitch(config)# interface e c3-c6 Command executed at
                                configuration level for
HPswitch(config)# interface e trk1 entering port or trk1 static
                                trunk-group context.

HPswitch(eth-C5-C8) #           Resulting prompt showing
HPswitch(eth-Trk1) #             port or static trunk
                                contexts.

```

HPswitch(eth-C5-C8) # ?

HPswitch(eth-C5-C8) # ?

Lists the commands you can use in the port or static trunk context, plus the Manager, Operator, and context commands you can execute at this level.

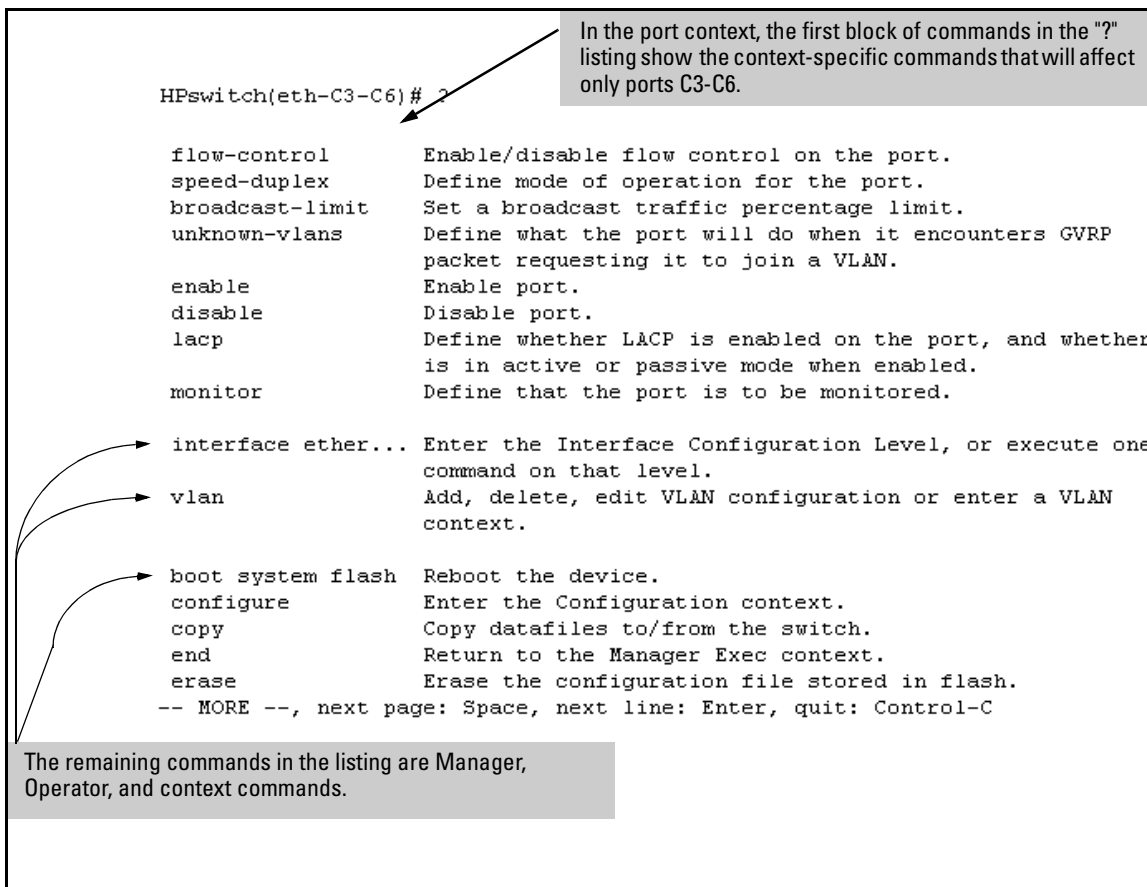

Figure 3-9. Context-Specific Commands Affecting Port Context



**VLAN Context .** Includes VLAN-specific commands that apply only to the selected VLAN, plus Manager and Operator commands. The prompt for this mode includes the VLAN ID of the selected VLAN. For example, if you had already configured a VLAN with an ID of 100 in the switch:

HPswitch(config)# vlan 100	Command executed at configuration level to enter VLAN 100 context.
HPswitch(vlan-100)#	Resulting prompt showing VLAN 100 context.
HPswitch(vlan-100)# ?	Lists commands you can use in the VLAN context, plus Manager, Operator, and context commands you can execute at this level.

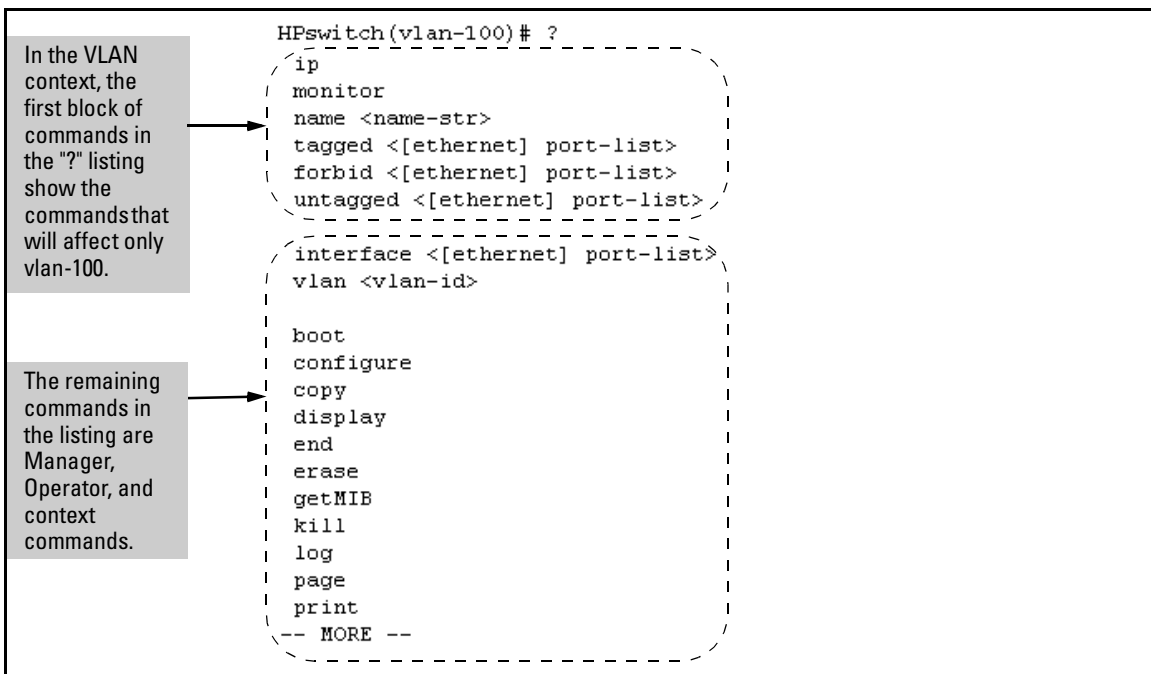

Figure 3-10. Context-Specific Commands Affecting VLAN Context

## CLI Control and Editing

Keystrokes	Function
<b>Ctrl</b> <b>A</b>	Jumps to the first character of the command line.
<b>Ctrl</b> <b>B</b> or <b>←</b>	Moves the cursor back one character.
<b>Ctrl</b> <b>C</b>	Terminates a task and displays the command prompt.
<b>Ctrl</b> <b>D</b>	Deletes the character at the cursor.
<b>Ctrl</b> <b>E</b>	Jumps to the end of the current command line.
<b>Ctrl</b> <b>F</b> or <b>→</b>	Moves the cursor forward one character.
<b>Ctrl</b> <b>K</b>	Deletes from the cursor to the end of the command line.
<b>Ctrl</b> <b>L</b> or <b>Ctrl</b> <b>R</b>	Repeats current command line on a new line.
<b>Ctrl</b> <b>N</b> or <b>↓</b>	Enters the next command line in the history buffer.
<b>Ctrl</b> <b>P</b> or <b>↑</b>	Enters the previous command line in the history buffer.
<b>Ctrl</b> <b>U</b> or <b>Ctrl</b> <b>X</b>	Deletes from the cursor to the beginning of the command line.
<b>Ctrl</b> <b>W</b>	Deletes the last word typed.
<b>Esc</b> <b>B</b>	Moves the cursor backward one word.
<b>Esc</b> <b>D</b>	Deletes from the cursor to the end of the word.
<b>Esc</b> <b>F</b>	Moves the cursor forward one word.
<b>Delete</b> or <b>Backspace</b>	Deletes the first character to the left of the cursor in the command line.

---

# Using the HP Web Browser Interface

---

## Contents

<b>Contents</b> .....	4-1
<b>Overview</b> .....	4-2
<b>General Features</b> .....	4-3
<b>Starting an HP Web Browser Interface Session with the Switch</b> ..	4-4
Using a Standalone Web Browser in a PC or UNIX Workstation . . . .	4-4
Using HP TopTools for Hubs & Switches .....	4-5
<b>Tasks for Your First HP Web Browser Interface Session</b> .....	4-7
Viewing the “First Time Install” Window .....	4-7
Creating Usernames and Passwords in the Browser Interface .....	4-8
Using the Passwords .....	4-10
Using the User Names .....	4-10
If You Lose a Password .....	4-11
Online Help for the HP Web Browser Interface .....	4-11
<b>Support/Mgmt URLs Feature</b> .....	4-12
Support URL .....	4-13
Help and the Management Server URL .....	4-13
<b>Status Reporting Features</b> .....	4-15
The Overview Window .....	4-15
The Port Utilization and Status Displays .....	4-16
Port Utilization .....	4-16
Port Status .....	4-18
The Alert Log .....	4-19
Sorting the Alert Log Entries .....	4-19
Alert Types .....	4-20
Viewing Detail Views of Alert Log Entries .....	4-21
The Status Bar .....	4-22
Setting Fault Detection Policy .....	4-23

## Overview

The HP web browser interface built into the switch lets you easily access the switch from a browser-based PC on your network. This lets you do the following:

- Optimize your network uptime by using the Alert Log and other diagnostic tools
- Make configuration changes to the switch
- Maintain security by configuring usernames and passwords

This chapter covers the following:

- General features (page 4-3).
- Starting a web browser interface session (page 4-4)
- Tasks for your first web browser interface session (page 4-7):
  - Creating usernames and passwords in the web browser interface (page 4-8)
  - Selecting the fault detection configuration for the Alert Log operation (page 4-23)
  - Getting access to online help for the web browser interface (page 4-11)
- Description of the web browser interface:
  - Overview window and tabs (page 4-15)
  - Port Utilization and Status displays (page 4-16)
  - Alert Log and Alert types (page 4-19)
  - Setting the Fault Detection Policy (page 4-23)

---

### Note

If you want security beyond that achieved with user names and passwords, you can disable access to the web browser interface. This is done by either executing **no web-management** at the Command Prompt or changing the **Web Agent Enabled** parameter setting to **No** (page 6-4).

---

## General Features

The Switch 4108GL include these web browser interface features:

Switch Configuration:

- Ports
- VLANs and Primary VLAN
- Fault detection
- Port monitoring (mirroring)
- System information
- Enable/Disable Multicast Filtering (IGMP) and Spanning Tree
- IP
- Stacking
- Support and management URLs

Switch Security: Passwords

Switch Diagnostics:

- Ping/Link Test
- Device reset
- Configuration report

Switch status

- Port utilization
- Port counters
- Port status
- Alert log

Switch system information listing

## Starting an HP Web Browser Interface Session with the Switch

You can start a web browser session in the following ways:

- Using a standalone web browser on a network connection from a PC or UNIX workstation:
  - Directly connected to your network
  - Connected through remote access to your network
- Using a management station running HP TopTools for Hubs & Switches on your network

### Using a Standalone Web Browser in a PC or UNIX Workstation

This procedure assumes that you have a supported web browser installed on your PC or workstation, and that an IP address has been configured on the switch. (For more on assigning an IP address, refer to "IP Configuration" on page 7-3.)

1. Make sure the Java™ applets are enabled for your browser. If they are not, use the options menu in your browser to do the following:
  - In Netscape, enable the **Java** and **JavaScript** options.
  - In Microsoft Internet Explorer, enable the **Java Permissions**.

Refer to your selected browser's online Help for specific information on enabling the Java applets.

2. Type the IP address (or DNS name) of the switch in the browser **Location or Address** field and press . (It is not necessary to include `http://`.)

**switch4108**  (example of a DNS-type name)

**10.11.12.195**  (example of an IP address)

If you are using a Domain Name Server (DNS), your device may have a name associated with it (for example, **switch4108**) that you can type in the **Location or Address** field instead of the IP address. Using DNS names typically improves browser performance. See your network administrator for any name associated with the switch.

## Using HP TopTools for Hubs & Switches

HP TopTools for Hubs & Switches is designed for installation on a network management workstation. For this reason, the HP TopTools system requirements are different from the system requirements for accessing the switch's web browser interface from a non-management PC or workstation. For HP TopTools requirements, refer to the information provided with HP TopTools for Hubs & Switches.

This procedure assumes that:

- You have installed the recommended web browser on a PC or workstation that serves as your network management station.
- The networked device you want to access has been assigned an IP address and (optionally) a DNS name and has been discovered by HP TopTools for Hubs & Switches. (For more on assigning an IP address, refer to "IP Configuration" on page 7-3.)

To establish a web browser session with HP TopTools running, do the following on the network management station:

1. Make sure the Java™ applets are enabled for your web browser. If they are not, refer to the web browser online Help for specific information on enabling the Java applets.
2. Do *one* of the following tasks:
  - On the HP TopTools Maps view, double-click on the symbol for the networking device that you want to access.
  - In HP TopTools, in the Topology Information dialog box, in the device list, double-click on the entry for the device you want to access (IP address or DNS name).

## Using the HP Web Browser Interface

Starting an HP Web Browser Interface Session with the Switch

- The web browser interface automatically starts with the Status Overview window displayed for the selected device, as shown in figure 4-1.

---

### Note

If the Registration window appears, click on the **Status** tab.

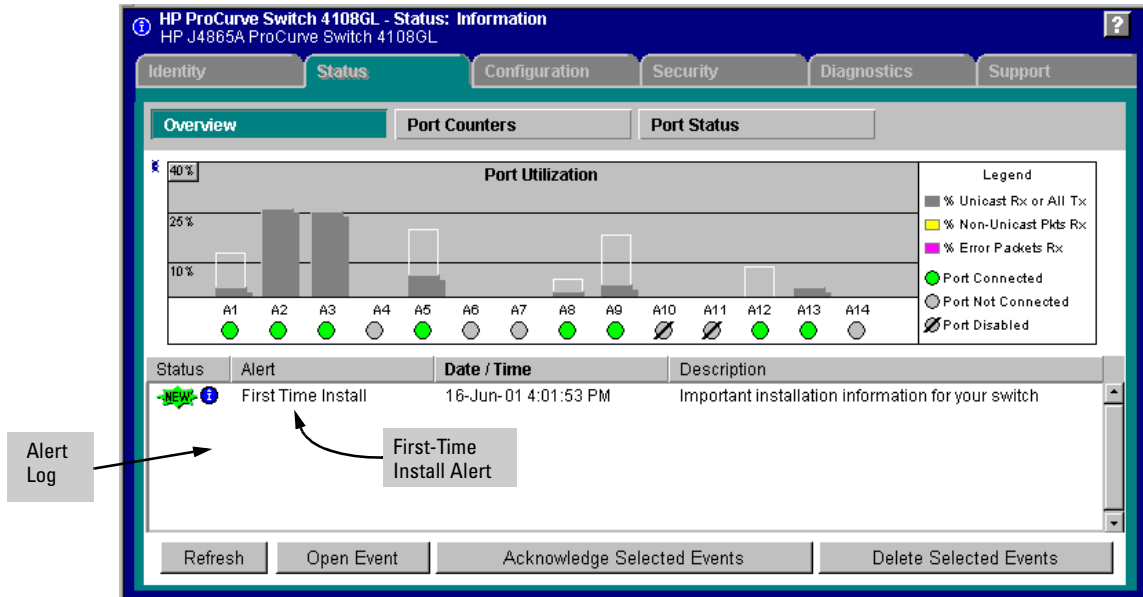

**Figure 4-1. Example of Status Overview Screen**

---

### Note

The above screen appears somewhat different if the switch is configured as a stack Commander. For an example, see figure 1-3 on page 1-5.



---

## Tasks for Your First HP Web Browser Interface Session

The first time you access the web browser interface, there are three tasks that you should perform:

- Review the “First Time Install” window
- Set Manager and Operator passwords
- Set access to the web browser interface online help

### Viewing the “First Time Install” Window

When you access the switch’s web browser interface for the first time, the Alert log contains a “First Time Install” alert, as shown in figure 4-2. This gives you information about first time installations, and provides an immediate opportunity to set passwords for security and to specify a Fault Detection policy, which determines the types of messages that will be displayed in the Alert Log.

Double click on **First Time Install** in the Alert log (figure 4-1 on page 4-6). The web browser interface then displays the “First Time Install” window, below.

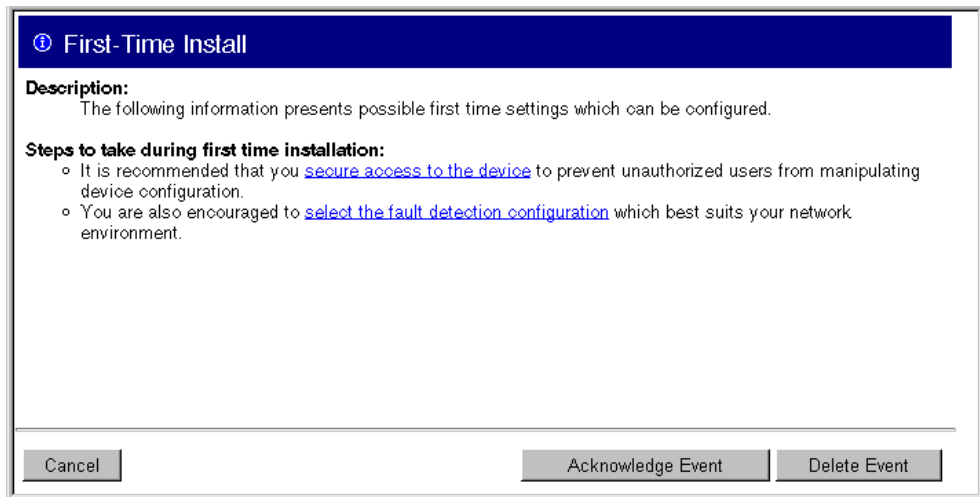

**Figure 4-2. First-Time Install Window**

This window is the launching point for the basic configuration you need to perform to set web browser interface passwords to maintain security and Fault Detection policy, which determines the types of messages that will be displayed in the Alert Log.

To set web browser interface passwords, click on **secure access to the device** to display the Device Passwords screen, and then go to the next page. (You can also access the password screen by clicking on the **Security** tab.)

To set Fault Detection policy, click on **select the fault detection configuration** in the second bullet in the window and go to the section, “Setting Fault Detection Policy” on page 4-23. (You can also access the password screen by clicking on the **Configuration** tab, and then [Fault Detection](#) button.)

## Creating Usernames and Passwords in the Browser Interface

You may want to create both a username and password to create access security for your switch. There are two levels of access to the interface that can be controlled by setting user names and passwords:

- **Operator.** An Operator-level user name and password allows read-only access to most of the web browser interface, but prevents access to the Security window.
- **Manager.** A Manager-level user name and password allows full read/write access to the web browser interface.

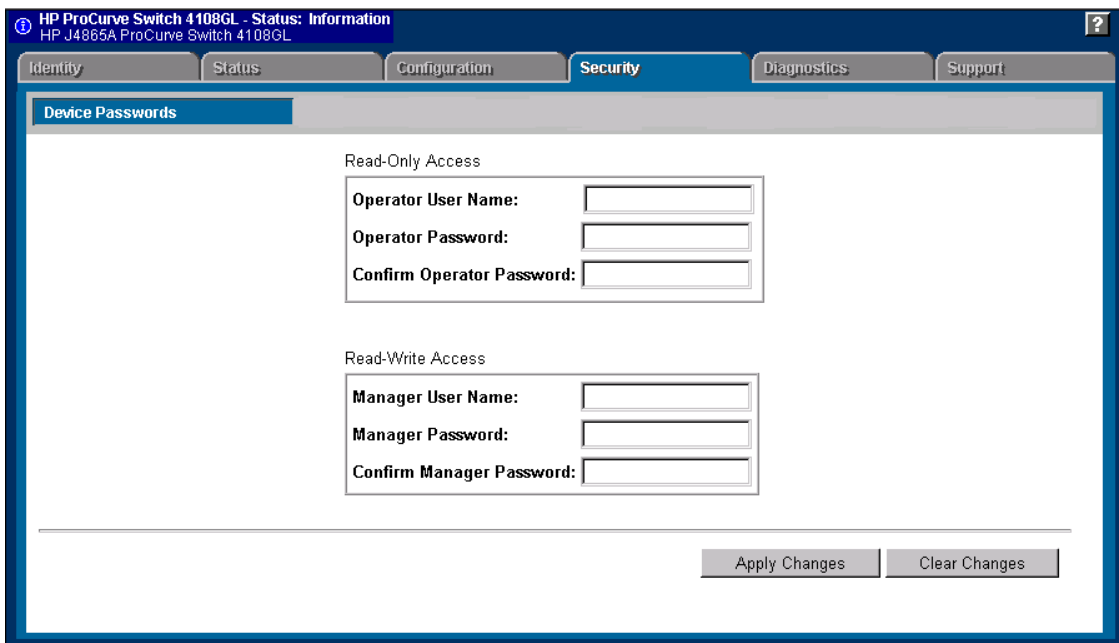

Figure 4-3. The Device Passwords Window

To set the passwords:

1. Access the Device Passwords screen by one of the following methods:
  - If the Alert Log includes a “First Time Install” event entry, double click on this event, then, in the resulting display, click on the **secure access to the device** link.
  - Select the **Security** tab.
2. Click in the appropriate box in the Device Passwords window and enter user names and passwords. You will be required to repeat the password strings in the confirmation boxes.

Both the user names and passwords can be up to 16 printable ASCII characters.

3. Click on  to activate the user names and passwords.

---

**Note**

Passwords you assign in the web browser interface will overwrite previous passwords assigned in either the web browser interface, the Command Prompt, or the switch console. That is, the most recently assigned passwords are the switch's passwords, regardless of which interface was used to assign the string.

---

## Using the Passwords

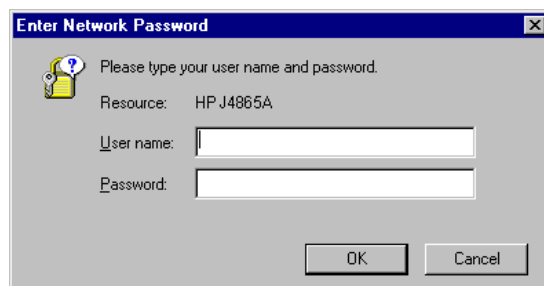

**Figure 4-4. Example of the Password Window in the Web Browser Interface**

The manager and operator passwords are used to control access to all switch interfaces. Once set, you will be prompted to supply the password every time you try to access the switch through any of its interfaces. The password you enter determines the capability you have during that session:

- Entering the manager password gives you full read/write capabilities
- Entering the operator password gives you read and limited write capabilities.

## Using the User Names

If you also set user names in the web browser interface screen, you must supply the correct user name for web browser interface access. If a user name has not been set, then leave the User Name field in the password window blank.

Note that the Command Prompt and switch console interfaces use only the password, and do not prompt you for the User Name.

## If You Lose a Password

If you lose the passwords, you can clear them by pressing the Clear button on the front of the switch. *This action deletes all password and user name protection from all of the switch's interfaces.*

*The Clear button is provided for your convenience, but its presence means that if you are concerned with the security of the switch configuration and operation, you should make sure the switch is installed in a secure location, such as a locked wiring closet.*

## Online Help for the HP Web Browser Interface

Online Help is available for the web browser interface. You can use it by clicking on the question mark button in the upper right corner of any of the web browser interface screens.

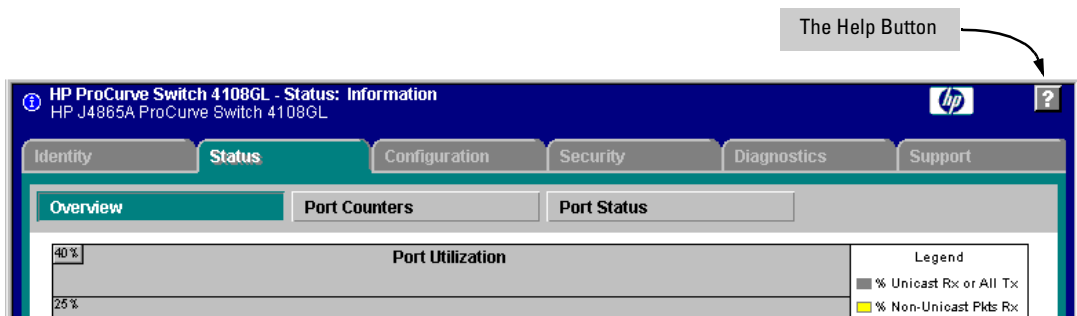

**Figure 4-5. The Help Button**

Context-sensitive help is provided for the screen you are on.

---

### Note

If you do not have HP TopTools for Hubs and Switches installed on your network and do not have an active connection to the World Wide Web, then Online help for the web browser interface will not be available.

For more on Help access and operation, refer to "Help and the Management Server URL" on page 4-13.

## Support/Mgmt URLs Feature

The Support/Mgmt URLs window enables you to change the World Wide Web Universal Resource Locator (URL) for two functions:

- **Support URL** – a support information site for your switch
- **Management Server URL** – the site for online help for the web browser interface, and, if set up, the URL of a network management station running HP TopTools for Hubs & Switches.

1. Click Here

2. Click Here

HP ProCurve Switch 4108GL - Status: Information  
HP J4865A ProCurve Switch 4108GL

Identity Status **Configuration** Security Diagnostics Support

Device View Fault Detection System Info IP Configuration  
Port Configuration Monitor Port Device Features Stacking  
VLAN Configuration **Support/Mgmt URL**

Support URL:

Management Server URL:

Apply Changes Clear Changes

3. Enter URLs for:  
- the support information source you want the switch to access when you click on the web browser interface Support tab – the default is HP's ProCurve network products World Wide Web home page  
- the URL of the network Management server or other source of the online help files for this web browser interface. (The default accesses Help on HP's World Wide Web site.)

4. Click on Apply Changes

Figure 4-6. The Default Support/Mgmt URLs Window

## Support URL

This is the site that the switch accesses when you click on the **Support** tab on the web browser interface. The default URL is:

**<http://www.hp.com/go/procurve>**

which is the World Wide Web site for Hewlett-Packard's networking products.

Click on the  button on that page and you can get to support information regarding your switch, including white papers, operating system (OS) updates, and more.

You could instead enter the URL for a local site that you use for entering reports about network performance, or whatever other function you would like to be able to easily access by clicking on the  tab.

## Help and the Management Server URL

This field specifies which of the following two locations the switch will use to find online Help for the web browser interface:

- The URL of online Help provided by HP on the world wide web
- The URL of a network management station running HP TopTools for Hubs & Switches

**Providing Online Help.** *The Help files are automatically available if you install HP TopTools for Hubs & Switches on your network or if you already have Internet access to the World Wide Web. (The Help files are included with HP TopTools for Hubs & Switches, and are also automatically available from HP via the World Wide Web.)*

Retrieval of the Help files is controlled by automatic entries to the **Management Server URL** field on the **Configuration / Support/Mgmt URLs** screen, shown in figure 4-6. The switch is shipped with the URL set to retrieve online Help from the HP World Wide Web site. However, if HP TopTools for Hubs & Switches is installed on a management station on your network and discovers the switch, the Management Server URL is automatically changed to retrieve the Help from your TopTools management station.

**If Online Help Fails To Operate.** Do one of the following:

- If HP TopTools for Hubs & Switches is installed and running on your network, enter the IP address or DNS name of the network management station in the Management Server URL field shown in figure 4-7 on page 4-14.

- If you have World Wide Web access from your PC or workstation, and do not have HP TopTools installed on your network, enter the following URL in the Management Server URL field shown in figure 4-7 on page 4-14:

[http://www.hp.com/rnd/device\\_help](http://www.hp.com/rnd/device_help)

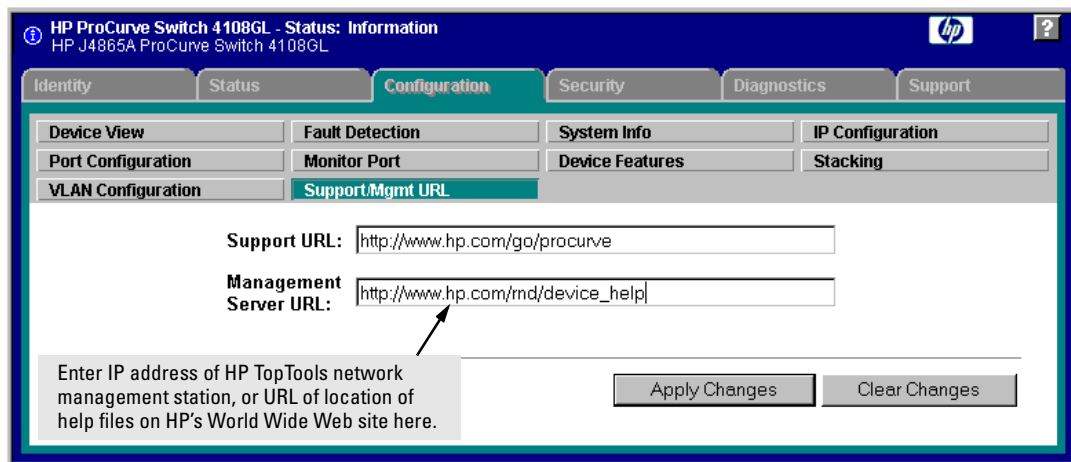

**Figure 4-7. How To Access Web Browser Interface Online Help**

**Policy Management and Configuration.** HP Top Tools for Hubs & Switches can perform network-wide policy management and configuration of your switch. The Management Server URL field identifies the management station that is performing that function. For more information, refer to the documentation provided on the HP TopTools for Hubs & Switches CD shipped with the switch.



## Status Reporting Features

Browser elements covered in this section include:

- The Overview window (below)
- Port utilization and status (page 4-16)
- The Alert log (page 4-19)
- The Status bar (page 4-22)

### The Overview Window

The Overview Window is the home screen for any entry into the web browser interface. The following figure identifies the various parts of the screen.

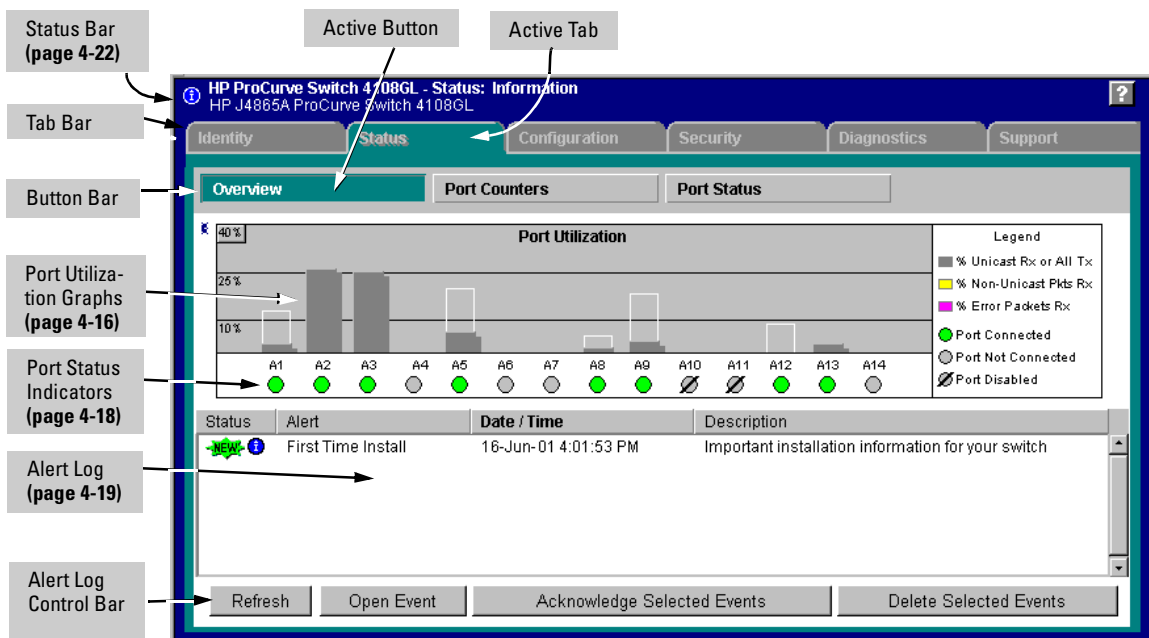

Figure 4-8. The Overview Window

## The Port Utilization and Status Displays

The Port Utilization and Status displays show an overview of the status of the switch and the amount of network activity on each port. The following figure shows a sample reading of the Port Utilization and Port Status.

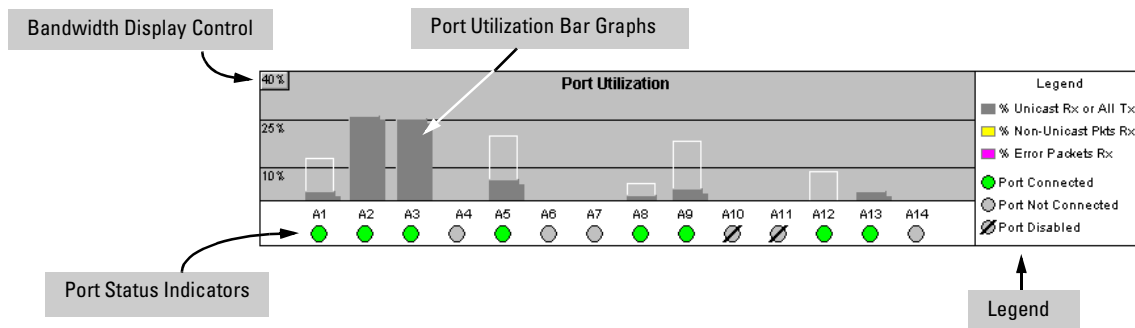

Figure 4-9. The Graphs Area

### Port Utilization

The Port Utilization bar graphs show the network traffic on the port with a breakdown of the packet types that have been detected (unicast packets, non-unicast packets, and error packets). The Legend identifies traffic types and their associated colors on the bar graph:

- **% Unicast Rx & All Tx:** This is all unicast traffic received and all transmitted traffic of any type. This indicator (a blue color on many systems) can signify either transmitted or received traffic.
- **% Non-Unicast Pkts Rx:** All multicast and broadcast traffic received by the port. This indicator (a gold color on many systems) enables you to know “at-a-glance” the source of any non-unicast traffic that is causing high utilization of the switch. For example, if one port is receiving heavy broadcast or multicast traffic, all ports will become highly utilized. By color-coding the received broadcast and multicast utilization, the bar graph quickly and easily identifies the offending port. This makes it faster and easier to discover the exact source of the heavy traffic because you don’t have to examine port counter data from several ports.
- **% Error Pkts Rx:** All error packets received by the port. (This indicator is a reddish color on many systems.) Although errors received on a port are not propagated to the rest of the network, a consistently high number of errors on a specific port may indicate a problem on the device or network segment connected to the indicated port.

- **Maximum Activity Indicator:** As the bars in the graph area change height to reflect the level of network activity on the corresponding port, they leave an outline to identify the maximum activity level that has been observed on the port.

**Utilization Guideline.** A network utilization of 40% is considered the maximum that a typical Ethernet-type network can experience before encountering performance difficulties. If you observe utilization that is consistently higher than 40% on any port, click on the Port Counters button to get a detailed set of counters for the port.

**To change the amount of bandwidth the Port Utilization bar graph shows.** Click on the bandwidth display control button in the upper left corner of the graph. (The button shows the current scale setting, such as 40%.) In the resulting menu, select the bandwidth scale you want the graph to show (3%, 10%, 25%, 40%, 75%, or 100%), as shown in figure figure 4-10.

Note that when viewing activity on a gigabit port, you may want to select a lower value (such as 3% or 10%). This is because the bandwidth utilization of current network applications on gigabit links is typically minimal, and may not appear on the graph if the scale is set to show high bandwidth utilization.

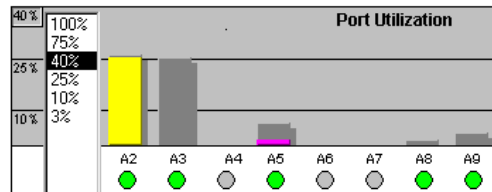

Figure 4-10. Changing the Graph Area Scale

**To display values for each graph bar.** Hold the mouse cursor over any of the bars in the graph, and a pop-up display is activated showing the port identification and numerical values for each of the sections of the bar, as shown in figure 4-11 (next).

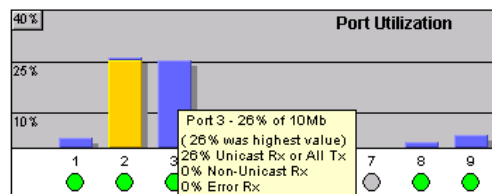
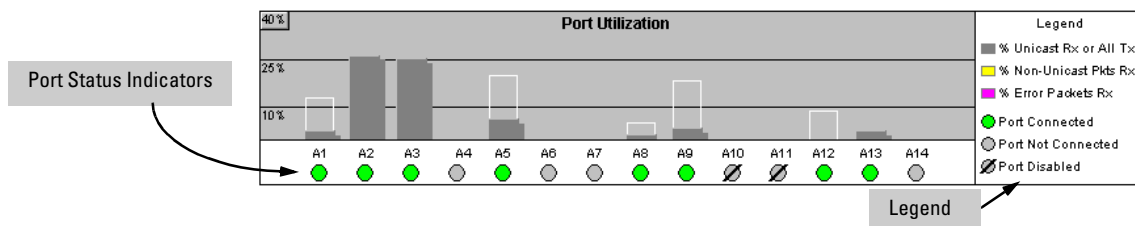

Figure 4-11. Display of Numerical Values for the Bar

## Port Status







**Figure 4-12. The Port Status Indicators and Legend**

The Port Status indicators show a symbol for each port that indicates the general status of the port. There are four possible statuses:

- **Port Connected** – the port is enabled and is properly connected to an active network device.
- **Port Not Connected** – the port is enabled but is not connected to an active network device. A cable may not be connected to the port, or the device at the other end may be powered off or inoperable, or the cable or connected device could be faulty.
- **Port Disabled** – the port has been configured as disabled through the web browser interface, the switch console, or SNMP network management.
- **Port Fault-Disabled** – a fault condition has occurred on the port that has caused it to be auto-disabled. Note that the Port Fault-Disabled symbol will be displayed in the legend only if one or more of the ports is in that status. See appendix B, “Monitoring and Analyzing Switch Operation” for more information.

## The Alert Log

The web browser interface Alert Log, shown in the lower half of the screen, shows a list of network occurrences, or *alerts*, that were detected by the switch. Typical alerts are **Broadcast Storm**, indicating an excessive number of broadcasts received on a port, and **Problem Cable**, indicating a faulty cable. A full list of alerts is shown in the table on page 4-20.

Status	Alert	Date / Time	Description
 	Excessive CRC/alignment errors	16-Sep-99 7:58:44 AM	Excessive CRC/Alignment errors on port 8.
 	First time installation	13-Sep-99 3:36:29 PM	Important installation information for your switch

Refresh    Open Event    Acknowledge Selected Events    Delete Selected Events

**Figure 4-13. Example of the Alert Log**

Each alert has the following fields of information:

- **Status** – The level of severity of the event generated. Severity levels can be Information, Normal, Warning, and Critical. If the alert is new (has not yet been acknowledged), the New symbol is also in the Status column.
- **Alert** – The specific event identification.
- **Date/Time** – The date and time the event was received by the web browser interface. This value is shown in the format: **DD-MM-YY HH:MM:SS AM/PM**, for example, **16-Sep-99 7:58:44 AM**.
- **Description** – A short narrative statement that describes the event. For example, **Excessive CRC/Alignment errors on port: 8**.

### Sorting the Alert Log Entries

The alerts are sorted, by default, by the Date/Time field with the most recent alert listed at the top of the list. The second most recent alert is displayed below the top alert and so on. If alerts occurred at the same time, the simultaneous alerts are sorted by order in which they appear in the MIB.

The alert field that is being used to sort the alert log is indicated by which column heading is in bold. You can sort by any of the other columns by clicking on the column heading. The Alert and Description columns are sorted alphabetically, while the Status column is sorted by severity type, with more critical severity indicators appearing above less critical indicators.

## Alert Types

The following table lists the types of alerts that can be generated.

**Table 4-1. Alert Strings and Descriptions**

Alert String	Alert Description
First Time Install	Important installation information for your switch.
Too many undersized/giant packets	A device connected to this port is transmitting packets shorter than 64 bytes or longer than 1518 bytes (longer than 1522 bytes if tagged), with valid CRCs (unlike runts, which have invalid CRCs).
Excessive jabbering	A device connected to this port is incessantly transmitting packets (“jabbering”), detected as oversized packets with CRC errors.
Excessive CRC/alignment errors	A high percentage of data errors has been detected on this port. Possible causes include: <ul style="list-style-type: none"><li>• Faulty cabling or invalid topology.</li><li>• Duplex mismatch (full-duplex configured on one end of the link, half-duplex configured on the other)</li><li>• A malfunctioning NIC, NIC driver, or transceiver</li></ul>
Excessive late collisions	Late collisions (collisions detected after transmitting 64 bytes) have been detected on this port. Possible causes include: <ul style="list-style-type: none"><li>• An overextended LAN topology</li><li>• Duplex mismatch (full-duplex configured on one end of the link, half-duplex configured on the other)</li><li>• A misconfigured or faulty device connected to the port</li></ul>
High collision or drop rate	A large number of collisions or packet drops have occurred on the port. Possible causes include: <ul style="list-style-type: none"><li>• A extremely high level of traffic on the port</li><li>• Duplex mismatch</li><li>• A misconfigured or malfunctioning NIC or transceiver on a device connected to this port</li><li>• A topology loop in the network</li></ul>
Excessive broadcasts	An extremely high percentage of broadcasts was received on this port. This degrades the performance of all devices connected to the port. Possible causes include: <ul style="list-style-type: none"><li>• A network topology loop—this is the usual cause</li><li>• A malfunctioning device, NIC, NIC driver, or software package</li></ul>
Loss of Link	Lost connection to one or multiple devices on the port.
Loss of stack member	The Commander has lost the connection to a stack member.

---

**Note**

---

When troubleshooting the sources of alerts, it may be helpful to check the switch's Port Status and Port Counter windows and the Event Log in the console interface.

### Viewing Detail Views of Alert Log Entries

By double clicking on Alert Entries, the web browser interface displays a Detail View or separate window detailing information about the events. The Detail View contains a description of the problem and a possible solution. It also provides four management buttons:

- **Acknowledge Event** – removes the New symbol from the log entry
- **Delete Event** – removes the alert from the Alert Log
- **Cancel Button** – closes the detail view with no change to the status of the alert and returns you to the Overview screen.

A sample Detail View describing an Excessive CRC/Alignment Error alert is shown here.

**Excessive CRC/Alignment Errors on port A8** 16-Sep-02 8:00:29 AM

**Description:**  
A high percentage of data errors was detected on port A8.

**Possible causes:**  
The possible causes include faulty cabling or topology, half/full duplex mismatch, a misconfigured NIC, or a malfunctioning NIC, NIC driver, or transceiver.

**Actions:**

1. If port A8 is 100Base-T, make sure the cable connectors, punch-down blocks, and patch panels connecting to that port are Category 5 or better. Verify the correctness of the installation using a Category 5 test device.
2. Check the directly-connected device for mismatches in half/full duplex operation (half duplex on the switch and full duplex on the connected device, or the reverse).
3. Update the NIC driver software.
4. Verify that the network topology conforms to IEEE 802.3 standards.
5. Replace or relocate the cable. Also check the wiring closet components, transceivers, and NICs for proper operation.

Cancel Retest Acknowledge Event Delete Event

**Figure 4-14. Example of Alert Log Detail View**

## The Status Bar

The Status Bar is displayed in the upper left corner of the web browser interface screen. Figure 4-15 shows an expanded view of the status bar.



**Figure 4-15. Example of the Status Bar**

The Status bar consists of four objects:

- **Status Indicator.** Indicates, by icon, the severity of the most critical alert in the current display of the Alert Log. This indicator can be one of three shapes and colors as shown in the following table.

**Table 4-2. Status Indicator Key**

Color	Switch Status	Status Indicator Shape
Blue	Normal Activity; "First time installation" information available in the Alert log.	
Green	Normal Activity	
Yellow	Warning	
Red	Critical	

- **System Name.** The name you have configured for the switch by using Identity screen, **system name** command, or the switch console **System Information** screen.
- **Most Critical Alert Description.** A brief description of the earliest, unacknowledged alert with the current highest severity in the Alert Log, appearing in the right portion of the Status Bar. In instances where multiple critical alerts have the same severity level, only the earliest unacknowledged alert is deployed in the Status bar.



- **Product Name.** The product name of the switch to which you are connected in the current web browser interface session.

## Setting Fault Detection Policy

One of the powerful features in the web browser interface is the Fault Detection facility. For your switch, this feature controls the types of alerts reported to the Alert Log based on their level of severity.

Set this policy in the Fault Detection window (figure 4-16).

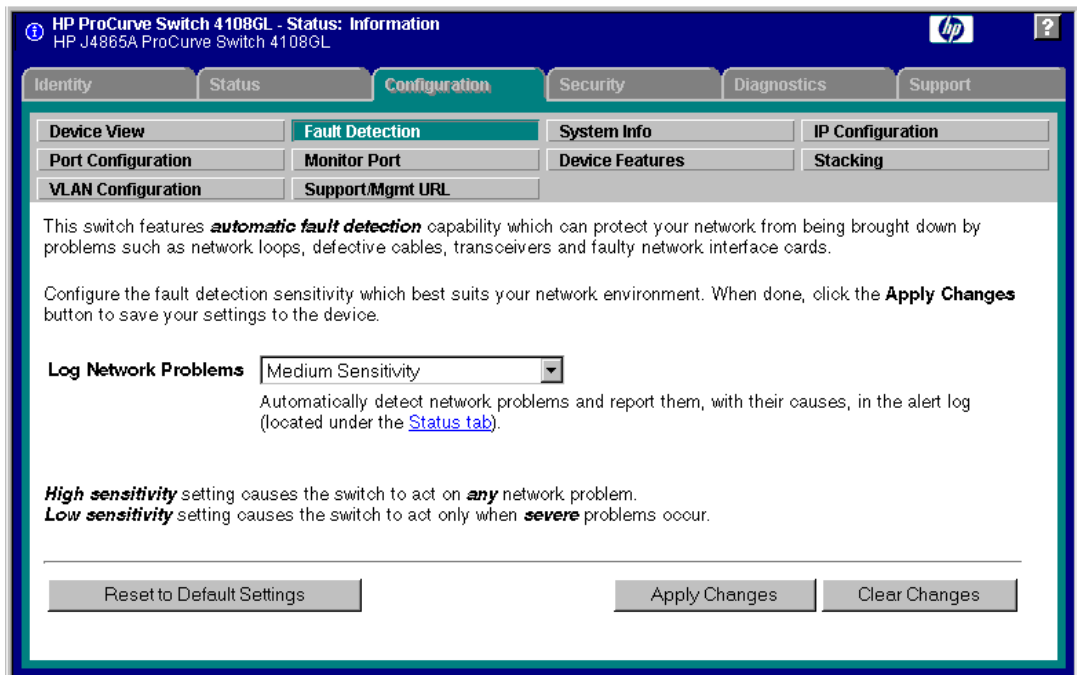

**Figure 4-16. The Fault Detection Window**

The Fault Detection screen contains a list box for setting fault detection and response policy. You set the sensitivity level at which a network problem should generate an alert and send it to the Alert Log.

To provide the most information on network problems in the Alert Log, the recommended sensitivity level for **Log Network Problems** is **High Sensitivity**. The Fault Detection settings are:

- **High Sensitivity.** This policy directs the switch to send all alerts to the Alert Log. This setting is most effective on networks that have none or few problems.
- **Medium Sensitivity.** This policy directs the switch to send alerts related to network problems to the Alert Log. If you want to be notified of problems which cause a noticeable slowdown on the network, use this setting.
- **Low Sensitivity.** This policy directs the switch to send only the most severe alerts to the Alert Log. This policy is most effective on a network that normally has a lot of problems and you want to be informed of only the most severe ones.
- **Never.** Disables the Alert Log and transmission of alerts (traps) to the management server (in cases where a network management tool such as HP TopTools for Hubs & Switches is in use). Use this option when you don't want to use the Alert Log.

The Fault Detection Window also contains three Change Control Buttons:

- **Apply Changes.** This button stores the settings you have selected for all future sessions with the web browser interface until you decide to change them.
- **Clear Changes.** This button removes your settings and returns the settings for the list box to the level it was at in the last saved detection-setting session.
- **Reset to Default Settings.** This button reverts the policy setting to Medium Sensitivity for Log Network Problems.

# Switch Memory and Configuration

---

## Contents

<b>Contents</b> .....	5-1
<b>Overview</b> .....	5-2
<b>Overview of Configuration File Management</b> .....	5-2
<b>Using the CLI To Implement Configuration Changes</b> .....	5-4
<b>Using the Menu and Web Browser Interfaces To Implement Configuration Changes</b> .....	5-8
Using the Menu Interface To Implement Configuration Changes ...	5-9
Using Save and Cancel in the Menu Interface .....	5-9
Rebooting from the Menu Interface .....	5-10
Using the Web Browser Interface To Implement Configuration Changes .....	5-11
<b>Using Primary and Secondary Flash Image Options</b> .....	5-12
Displaying the Current Flash Image Data .....	5-12
OS Downloads .....	5-14
Local OS Replacement and Removal .....	5-15
Rebooting the Switch .....	5-17
Operating Notes .....	5-19

## Overview

This chapter describes:

- How switch memory manages configuration changes
  - How the CLI implements configuration changes
  - How the menu interface and web browser interface implement configuration changes
  - How the switch provides OS (operating system) options through primary/secondary flash image options
  - How to use the switch's primary and secondary flash options, including displaying flash information, booting or restarting the switch, and other topics
- 

## Overview of Configuration File Management

The switch maintains two configuration files, the *running-config* file and the *startup-config* file.

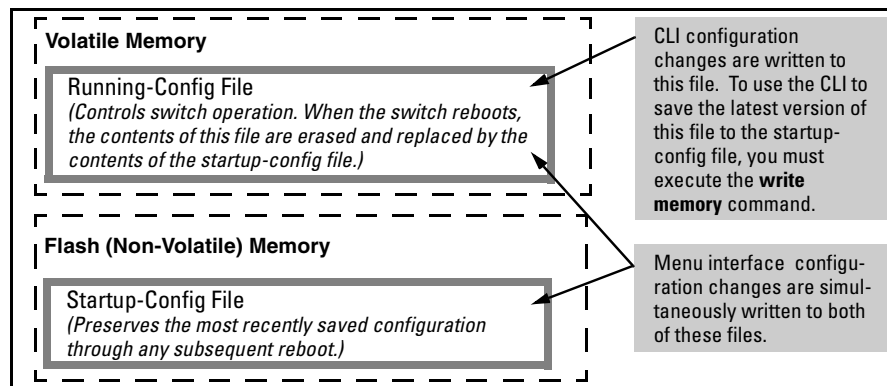

Figure 5-1. Conceptual Illustration of Switch Memory Operation

- **Running Config File:** Exists in volatile memory and controls switch operation. If no configuration changes have been made in the CLI since the switch was last booted, the running-config file is identical to the startup-config file.
- **Startup-config File:** Exists in flash (non-volatile) memory and is used to preserve the most recently-saved configuration as the "permanent" configuration.

Rebooting the switch replaces the current running-config file with a new running-config file that is an exact copy of the current startup-config file.

---

**Note**

Any of the following actions reboots the switch:

- Executing the **boot** or the **reload** command in the CLI
- Executing the **Reboot** command in the menu interface
- Pressing the Reset button on the front of the switch
- Removing, then restoring power to the switch

For more on reboots and the switch's dual-flash images, see "Using Primary and Secondary Flash Image Options" on page 5-12.

---

**Options for Saving a New Configuration.** Making one or more changes to the running-config file creates a new operating configuration. *Saving* a new configuration means to overwrite (replace) the current startup-config file with the current running-config file. This means that if the switch subsequently reboots for any reason, it will resume operation using the new configuration instead of the configuration previously defined in the startup-config file. There are three ways to save a new configuration:

- **In the CLI:** Use the **write memory** command. This overwrites the current startup-config file with the contents of the current running-config file.
- **In the menu interface:** Use the **Save** command. This overwrites *both* the running-config file and the startup-config file with the changes you have specified in the menu interface screen.
- **In the web browser interface:** Use the Apply Changes button or other appropriate button. This overwrites *both* the running-config file and the startup-config file with the changes you have specified in the web browser interface window.

Note that using the CLI instead of the menu or web browser interface gives you the option of changing the running configuration without affecting the startup configuration. This allows you to test the change without making it

"permanent". When you are satisfied that the change is satisfactory, you can make it permanent by executing the **write memory** command. For example, suppose you use the following command to disable port 5:

```
HPswitch(config)# interface ethernet 5 disable
```

The above command disables port 5 in the running-config file, but not in the startup-config file. Port 5 remains disabled only until the switch reboots. If you want port 5 to remain disabled through the next reboot, use **write memory** to save the current running-config file to the startup-config file in flash memory.

```
HPswitch(config)# write memory
```

If you use the CLI to make a configuration change and then change from the CLI to the Menu interface without first using write memory to save the change to the startup-config file, then the switch prompts you to save the change. For example, if you use the CLI to create VLAN 20, and then select the menu interface, VLAN 20 is configured in the running-config file, but not in the startup-config file. In this case you will see:

```
HPswitch(config)# vlan 20
HPswitch(config)# menu
Do you want to save current configuration [y/n]?
```

If you type Y, the switch overwrites the startup-config file with the running-config file, and your configuration change(s) will be preserved across reboots. If you type N, your configuration change(s) will remain only in the running-config file. In this case, if you do not subsequently save the running-config file, your unsaved configuration changes will be lost if the switch reboots for any reason.

**Storing and Retrieving Configuration Files.** You can store or retrieve a backup copy of the startup-config file on another device. For more information, see appendix A, "Transferring an Operating System or Startup-Config File"

---

## Using the CLI To Implement Configuration Changes

The CLI offers these capabilities:

- Access to the full set of switch configuration features
- The option of testing configuration changes before making them permanent

**How To Use the CLI To View the Current Configuration Files.** Use **show** commands to view the configuration for individual features, such as port status or Spanning Tree Protocol. However, to view either the entire startup-config file or the entire running-config file, use the following commands:

- **show config** — Displays a listing of the current startup-config file.
- **show running-config** — Displays a listing of the current running-config file.
- **write terminal** — Displays a listing of the current running-config file.
- **show config status** — Compares the startup-config file to the running-config file and lists one of the following results:
  - If the two configurations are the same you will see:
    - Running configuration is the same as the startup configuration.
  - If the two configurations are different, you will see:
    - Running configuration has been changed and needs to be saved.

---

**Note**

---

**Show config** , **show running-config**, and **write terminal** commands display the configuration settings that differ from the switch's factory-default configuration.

**How To Use the CLI To Reconfigure Switch Features.** Use this procedure to permanently change the switch configuration (that is, to enter a change in the startup-config file).

1. Use the appropriate CLI commands to reconfigure the desired switch parameters. This updates the selected parameters in the running-config file.
2. Use the appropriate **show** commands to verify that you have correctly made the desired changes.
3. Observe the switch's performance with the new parameter settings to verify the effect of your changes.
4. When you are satisfied that you have the correct parameter settings, use the **write memory** command to copy the changes to the startup-config file.

**Syntax:**    `write memory`

For example, the default port mode setting is **auto**. Suppose that your network uses Cat 3 wiring and you want to connect the switch to another autosensing device capable of 100 Mbps operation. Because 100 Mbps over Cat 3 wiring can introduce transmission problems, the recommended port mode is **auto-10**, which allows the port to negotiate full- or half-duplex, but restricts speed to 10 Mbps. The following command configures port A5 to auto-10 mode in the running-config file, allowing you to observe performance on the link without making the mode change permanent.

```
HPswitch(config)# interface e a5 speed-duplex auto-10
```

After you are satisfied that the link is operating properly, you can save the change to the switch's permanent configuration (the startup-config file) by executing the following command:

```
HPswitch(config)# write memory
```

The new mode (**auto-10**) on port A5 is now saved in the startup-config file, and the startup-config and running-config files are identical. If you subsequently reboot the switch, the **auto-10** mode configuration on port A5 will remain because it is included in the startup-config file.

### **How To Cancel Changes You Have Made to the Running-Config File.**

If you use the CLI to change parameter settings in the running-config file, and then decide that you don't want those changes to remain, you can use either of the following methods to remove them:

- Manually enter the earlier values you had for the changed settings. (This is recommended if you want to restore a small number of parameter settings to their previous boot-up values.)
- Update the running-config file to match the startup-config file by rebooting the switch. (This is recommended if you want to restore a larger number of parameter settings to their previous boot-up values.)

If you use the CLI to change a parameter setting, and then execute the **boot** command without first executing the **write memory** command to save the change, the switch prompts you to specify whether to save the changes in the current running-config file. For example:



```
Disables port 1 in the running configuration, which causes port 1 to block all traffic.
HPswitch(config)# interface e 1 disable
HPswitch(config)# boot
Device will be rebooted, do you want to continue [y/n]? y
Press [Y] to continue the rebooting process.
You will then see this prompt.
Do you want to save current configuration [y/n]?
```

**Figure 5-2. Boot Prompt for an Unsaved Configuration**

The above prompt means that one or more parameter settings in the running-config file differ from their counterparts in the startup-config file and you need to choose which config file to retain and which to discard.

- If you want to update the startup-config file to match the running-config file, press **[Y]** for "yes". (This means that the changes you entered in the running-config file will be saved in the startup-config file.)
- If you want to discard the changes you made to the running-config file so that it will match the startup-config file, then press **[N]** for "no". (This means that the switch will discard the changes you entered in the running-config file and will update the running-config file to match the startup-config file.)

---

**Note**

If you use the CLI to make a change to the running-config file, you should either use the **write memory** command or select the save option allowed during a reboot (figure 5-2, above) to save the change to the startup-config file. That is, if you use the CLI to change a parameter setting, but then reboot the switch from either the CLI or the menu interface without first executing the **write memory** command in the CLI, the current startup-config file will replace the running-config file, and any changes in the running-config file will be lost.

Using the **Save** command in the menu interface does not save a change made to the running config by the CLI unless you have also made a configuration change in the menu interface. Also, the menu interface displays the current running-config values. Thus, where a parameter setting is accessible from both the CLI and the menu interface, if you change the setting in the CLI, the new value will appear in the menu interface display for that parameter.

*However, as indicated above, unless you also make a configuration change in the menu interface, only the **write memory** command in the CLI will actually save the change to the startup-config file.*

**How To Reset the startup-config and running-config Files to the Factory-Default Configuration.** This command reboots the switch, replacing the contents of the current startup-config and running-config files with the factory-default startup configuration.

**Syntax:** erase startup-config

For example:

```
HPswitch(config)# erase startup-config
Configuration will be deleted and device rebooted, continue [y/n]?
```

**Figure 5-3. Resetting to the Factory-Default Configuration**

Press  to replace the current configuration with the factory default configuration and reboot the switch. Press  to retain the current configuration and prevent a reboot.

---

## Using the Menu and Web Browser Interfaces To Implement Configuration Changes

The menu and web browser interfaces offer these advantages:

- Quick, easy menu or window access to a subset of switch configuration features (See the "Menu Features List" on page 2-14 and the web browser "General Features" list on page .)
- Viewing several related configuration parameters in the same screen, with their default and current settings
- Immediately changing both the running-config file and the startup-config file with a single command

## Using the Menu Interface To Implement Configuration Changes

You can use the menu interface to simultaneously save and implement a subset of switch configuration changes without having to reboot the switch. That is, when you save a configuration change in the menu interface, you simultaneously change both the running-config file and the startup-config file.

---

### Note

---

The only exception to this operation are two VLAN-related parameter changes that require a reboot—described under "Rebooting To Activate Configuration Changes" on page 5-11.

### Using **Save** and **Cancel** in the Menu Interface

For any configuration screen in the menu interface, the Save command:

1. Implements the changes in the running-config file
2. Saves your changes to the startup-config file

If you decide not to save and implement the changes in the screen, select **Cancel** to discard them and continue switch operation with the current operation. For example, suppose you have made the changes shown below in the System Information screen:

To save and implement the changes for all parameters in this screen, press the **Enter** key, then press **S** (for **Save**). To cancel all changes, press the **Enter** key, then press **C** (for **Cancel**)

```
----- CONSOLE - MANAGER MODE -----
Switch Configuration - System Information

System Name : HP ProCurve Switch 4104GL
System Contact : Extension 5440
System Location : System Support Office, Floor 2, Room 231

Inactivity Timeout (min) [0] : 0      Address Age Interval (min) [5] : 5
Inbound Telnet Enabled [Yes] : Yes    Web Agent Enabled [Yes] : Yes

Time Zone [0] : 8
Daylight Time Rule [None] : Continental-US-and-Canada

Actions->  _Cancel      _Edit      _Save      _Help

Select Daylight Time Rule for your location.
Use arrow keys to change field selection, <Space> to toggle field choices,
and <Enter> to go to Actions.
```

**Figure 5-4. Example of Pending Configuration Changes that Can Be Saved or Cancelled**

---

#### Note

If you reconfigure a parameter in the CLI and then go to the menu interface without executing a **write memory** command, those changes are stored only in the running configuration (even if you execute a Save operation in the menu interface). If you then execute a switch reboot command in the menu interface, the switch discards the configuration changes made while using the CLI. To ensure that changes made while using the CLI are saved, execute **write memory** in the CLI before rebooting the switch.

---

### Rebooting from the Menu Interface

- Terminates the current session and performs a reset of the operating system
- Activates any configuration changes that require a reboot
- Resets statistical counters to zero

(Note that statistical counters can be reset to zero without rebooting the switch. See “Displaying Port Counters” on “To Display the Port Counter Summary Report” on page B-11.)

To Reboot the switch, use the **Reboot Switch** option in the Main Menu. (Note that the Reboot Switch option is not available if you log on in Operator mode; that is, if you enter an Operator password instead of a manager password at the password prompt.)

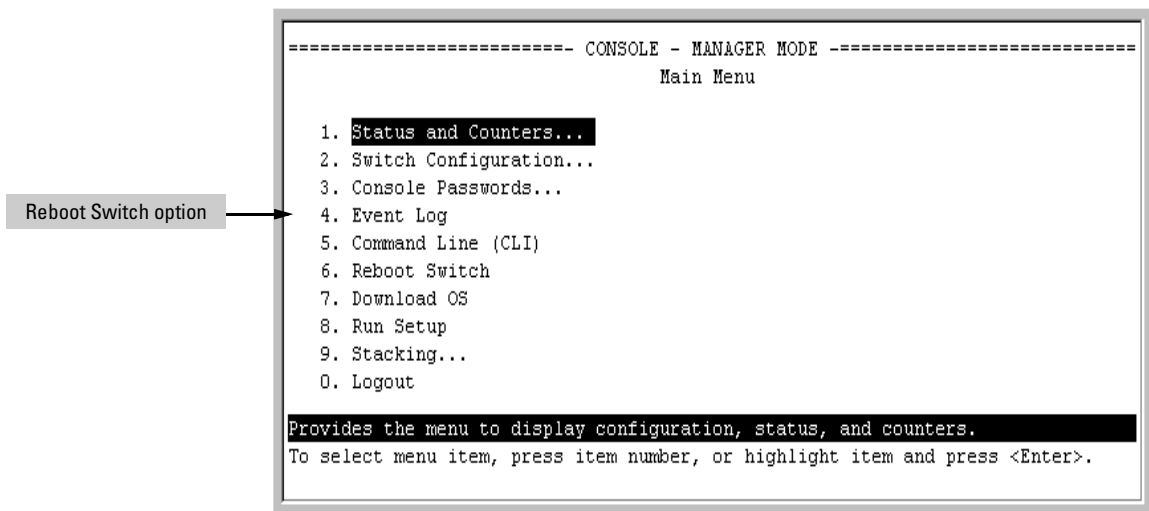
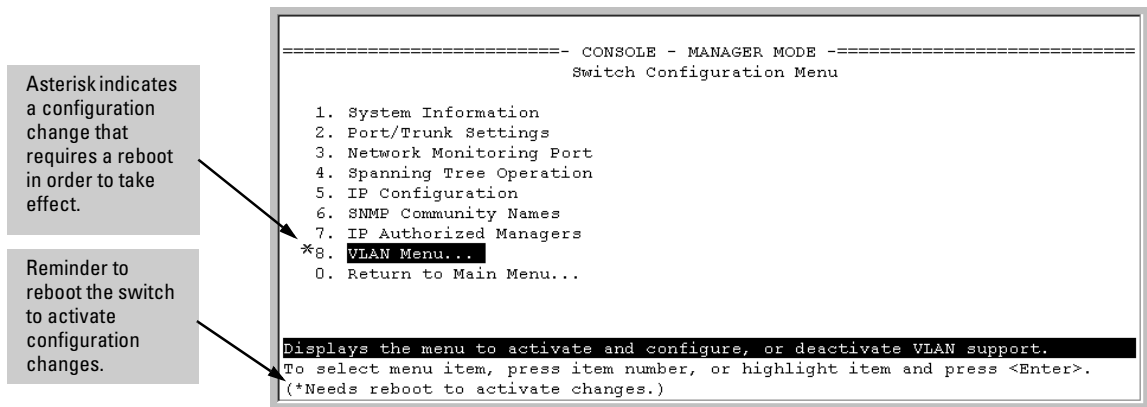

Figure 5-5. The Reboot Switch Option in the Main Menu

**Rebooting To Activate Configuration Changes.** Configuration changes for most parameters become effective as soon as you save them. However, you must reboot the switch in order to implement a change in the **Maximum VLANs to support** parameter.

(To access these parameters, go to the Main menu and select **2. Switch Configuration**, then **8. VLAN Menu**, then **1. VLAN Support**.)

If configuration changes requiring a reboot have been made, the switch displays an asterisk (\*) next to the menu item in which the change has been made. For example, if you change and save parameter values for the **Maximum VLANs to support** parameter, an asterisk appears next to the **VLAN Support** entry in the VLAN Menu screen, and also next to the **Switch Configuration ...** entry in the Main menu, as shown in figure 4-6:



**Figure 5-6. Indication of a Configuration Change Requiring a Reboot**

## Using the Web Browser Interface To Implement Configuration Changes

You can use the web browser interface to simultaneously save and implement a subset of switch configuration changes without having to reboot the switch. That is, when you save a configuration change (in most cases, by clicking on **Apply Changes** or **Apply Settings**), you simultaneously change both the running-config file and the startup-config file.

---

**Note**

If you reconfigure a parameter in the CLI and then go to the browser interface without executing a **write memory** command, those changes will be saved to the startup-config file if you click on [Apply Changes](#) or [Apply Settings](#) in the web browser interface.

---

---

## Using Primary and Secondary Flash Image Options

The Series 4100GL switches feature two flash memory locations for storing system image (operating system, or OS) files:

- **Primary Flash:** The default storage for OS (system image) files.
- **Secondary Flash:** The additional storage for either a redundant or an alternate OS (system image) file.

With the Primary/Secondary flash option you can test a new image in your system without having to replace a previously existing image. You can also use the image options for troubleshooting. For example, you can copy a problem image into Secondary flash for later analysis and place another, proven image in Primary flash to run your system. The switch can use only one image at a time.

The following tasks involve primary/secondary flash options:

- Displaying the current flash image data and determining which OS versions are available
- OS downloads
- Local OS replacement, and removal (erasing)
- System booting

### Displaying the Current Flash Image Data

Use the commands in this section to:

- Determine whether there are flash images in both primary and secondary flash
- Determine whether the images in primary and secondary flash are the same

- Identify which OS version is currently running

**Viewing the Currently Active Flash Image Version.** This command identifies the software version on which the switch is currently running, and whether the active version was booted from the primary or secondary flash image.

**Syntax:** show version

For example, if the switch is using an OS version of G.01.01 stored in Primary flash, **show version** produces the following:

```
HPswitch(config)# show version
Image stamp:   /sw/code/build/info(s01)
               Jun 01 2002 10:50:26
               G.05.01
               1796
Boot Image:    Primary
```

**Figure 5-7. Example Showing the Identity of the Current Flash Image**

**Determining Whether the Flash Images Are Different Versions.** If the flash image sizes in primary and secondary are the same, then in almost every case, the primary and secondary images are identical. This command provides a comparison of flash image sizes, plus the boot ROM version and from which flash image the switch booted. For example, in the following case, the images are different versions of the OS software (flash image) and the switch is running on the version stored in the secondary flash image:

```
HPswitch(config)# show flash
Image           Size(Bytes)   Date      Version
-----
Primary Image   : 2589041    06/01/02  G.05.01
Secondary Image : 2687489    05/05/02  G.05.00
Boot Rom Version: G.05.X1
Current Boot    : Primary
```

The unequal code size and differing dates indicate two different versions of the OS software.

**Figure 5-8. Example Showing Different Flash Image Versions**

**Determining Which Flash Image Versions Are Installed.** The **show version** command displays which software version the switch is currently running and whether that version booted from primary or secondary flash. Thus, if the switch booted from primary flash, you will see the version number of the OS image stored in primary flash, and if the switch booted from secondary flash, you will see the version number of the OS version stored in secondary flash.

Thus, by using **show version**, then rebooting the switch from the opposite flash image and using **show version** again, you can determine the version of the OS image in both flash sources. For example:

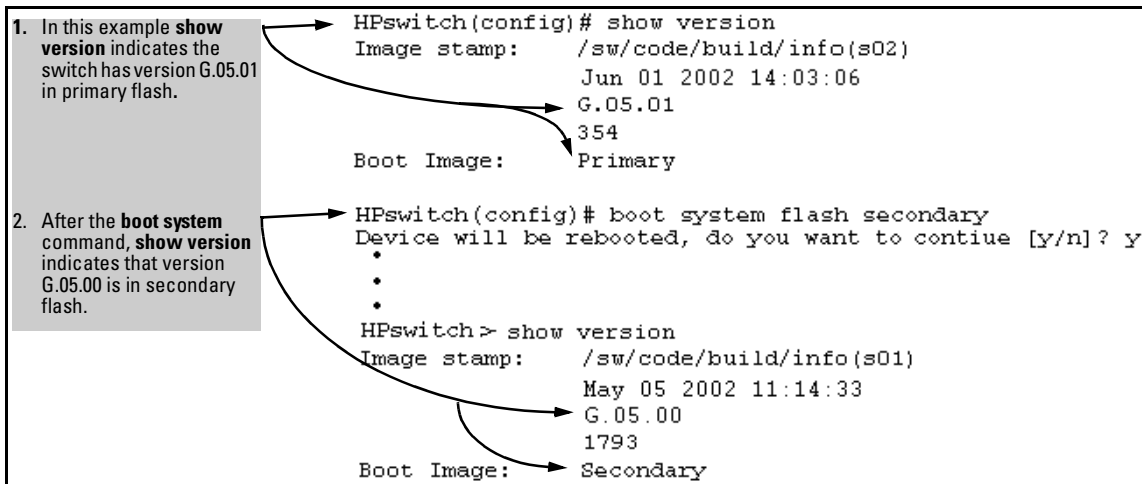

**Figure 5-9. Determining the OS Version in Primary and Secondary Flash**

## OS Downloads

The following table shows the switch’s options for downloading an OS to flash and booting the switch from flash

**Table 5-1. Primary/Secondary Memory Access**

Action	Menu	CLI	Web Browser	SNMP
Download to Primary	Yes	Yes	Yes	Yes
Download to Secondary	No	Yes	No	Yes
Boot from Primary	Yes	Yes	Yes	Yes
Boot from Secondary	No	Yes	No	Yes

The different OS download options involve different **copy** commands, plus **xmodem**, and **ftp**. These topics are covered in Chapter A, “File Transfers”.

**Download Interruptions.** In most cases, if a power failure or other cause interrupts a flash image download, the switch reboots with the image previously stored in primary flash. In the unlikely event that the primary image is corrupted, as a result of an interruption, the switch will reboot from secondary



flash and you can either copy the secondary image into primary or download another image to primary from an external source. See Appendix A, “File Transfers”.

## Local OS Replacement and Removal

This section describes commands for erasing an OS (flash image) and copying an existing OS between primary and secondary flash.

---

### Note

It is not necessary to erase the content of a flash location before downloading another OS file. The process automatically overwrites the previous file with the new file. If you want to remove an unwanted OS version from flash, HP recommends that you do so by overwriting it with the same OS version that you are using to operate the switch, or with another acceptable OS version. To copy an OS image file between the primary and secondary flash locations, see “Copying an OS Image from One Flash Location to Another”, below.

The local commands described here are for flash image management within the switch. To download an OS image file from an external source, see Appendix A, “File Transfers”.

---

**Copying an OS Image from One Flash Location to Another.** When you copy the flash image from primary to secondary or the reverse, the switch overwrites the file in the destination location with a copy of the file from the source location. This means you *do not* have to erase the current image at the destination location before copying in a new image.

---

### Caution

Verify that there is an acceptable OS image in the source flash location from which you are going to copy. Use the **show flash** command or, if necessary, the procedure under “Determining Which Flash Image Versions Are Installed” on page 5-13 to verify an acceptable OS image. Attempting to copy from a source image location that has a corrupted flash image overwrites the image in the destination flash location. In this case, the switch will not have a valid flash image in either flash location, but will continue running on a temporary flash image in RAM. *Do not reboot the switch.* Instead, immediately download another valid flash image to primary or secondary flash. Otherwise, if the switch is rebooted without an OS image in either primary or secondary flash, the temporary flash image in RAM will be cleared and the switch will go down. To recover, see “Restoring a Flash Image” on page C-35 (in the Troubleshooting chapter).

---

**Syntax:**    copy flash flash <destination flash>

where: *destination flash* = **primary** or **secondary**:

For example, to copy the image in secondary flash to primary flash:

1. Verify that there is a valid flash image in the secondary flash location. The following figure indicates that an OS image is present in secondary flash. (If you are unsure whether the image in secondary flash is valid, try booting from it before you proceed, by using **boot system flash secondary**.)

HPswitch(config)# show flash				The unequal code size, differing dates, and differing version numbers indicates two different versions of the OS software.
Image	Size (Bytes)	Date	Version	
-----	-----	-----	-----	
Primary Image	: 2589041	06/01/02	G.05.01	←
Secondary Image	: 2687489	05/05/02	G.05.00	←
Boot Rom Version: G.05.X1				
Current Boot : Primary				

**Figure 5-10. Example Indicating Two Different OS Versions in Primary and Secondary Flash**

Execute the copy command as follows:

```
HPswitch(config)# copy flash flash primary
```

**Erasing the Contents of Primary or Secondary Flash.** This command deletes the OS image file from the specified flash location.

---

**Caution--No Undo!**

---

Before using this command in one flash image location (primary or secondary), ensure that you have a valid OS file in the other flash image location (secondary or primary). If the switch has only one flash image loaded (in either primary or secondary flash) and you erase that image, then the switch does not have an OS stored in flash. In this case, if you do not reboot or power cycle the switch, you can recover by using xmodem or tftp to download another OS.

**Syntax:** erase flash < primary | secondary >

For example, to erase the OS in primary flash, do the following:

1. First verify that a usable flash image exists in secondary flash. The most reliable way to ensure this is to reboot the switch from the flash image you want to retain. For example, if you are planning to erase the primary image, then first reboot from the secondary image to verify that the secondary image is present and acceptable for your system:

```
HPswitch# boot system flash secondary
```

2. Then erase the OS in the selected flash (in this case, primary):

```

HPswitch# erase flash primary
The Primary OS Image will be deleted, continue [y/n]? _
    
```

The prompt shows which flash location will be erased.

**Figure 5-11. Example of Erase Flash Prompt**

3. Type **y** at the prompt to complete the flash erase.
4. Use **show flash** to verify erasure of the selected OS flash image

```

HPswitch# show flash
Compressed Primary Code size    = 0
Compressed Secondary Code size  = 2555802
Boot Rom Version:               G.05.X1
Current Boot:                   Secondary
    
```

The "0" here shows that primary flash has been erased.

**Figure 5-12. Example of Show Flash Listing After Erasing Primary Flash**

## Rebooting the Switch

The switch offers reboot options through the **boot** and **reload** commands, plus the options inherent in a dual-flash image system. Generally, using **boot** provides more comprehensive self-testing; using **reload** gives you a faster reboot time.

**Table 5-2. Comparing the Boot and Reload Commands**

Actions	Included In Boot?	Included In Reload	Note
Save all configuration changes since the last boot or reload	Optional, with prompt	Yes, automatic	Config changes saved to the startup-config file
Perform all system self-tests	Yes	No	Reload provides a faster system reboot.
Choice of primary or secondary	Yes	No—Uses the current flash image.	

**Booting from Primary Flash.** This command always boots the switch from primary flash, and executes the complete set of subsystem self-tests.

**Syntax:** boot

For example, to boot the switch from primary flash with pending configuration changes in the running-config file:

```
HPswitch(config)# boot
Device will be rebooted, do you want to continue [y/n]? y
Boot from primary flash
Do you want to save current configuration [y/n]? _
```

**Figure 5-13. Example of Boot Command (Default Primary Flash)**

In the above example, typing either a **y** or **n** at the second prompt initiates the reboot operation. Also, if there are no pending configuration changes in the running-config file, then the reboot commences without the pause to display Boot from primary flash.

**Booting from a Specified Flash.** This version of the boot command gives you the option of specifying whether to reboot from primary or secondary flash, and is the required command for rebooting from secondary flash. This option also executes the complete set of subsystem self-tests.

**Syntax:** boot system flash < primary | secondary >

For example, to reboot the switch from secondary flash when there are no pending configuration changes in the running-config file:

```
HPswitch(config)# boot system flash secondary
Device will be rebooted, do you want to continue [y/n]? y
Boot from secondary flash
Do you want to save current configuration [y/n]? _
```

**Figure 5-14. Example of Boot Command with Primary/Secondary Flash Option**

In the above example, typing either a **y** or **n** at the second prompt initiates the reboot operation. Also, if there are no pending configuration changes in the running-config file, then the reboot commences without the pause to display Boot from secondary flash.

**Booting from the Current OS Version. Reload** reboots the switch from the flash image on which the switch is currently running, and saves to the startup-config file any configuration changes currently in the running-config file. Because **reload** bypasses some subsystem self-tests, the switch reboots faster than if you use either of the **boot** command options.

**Syntax:**     reload

For example, if you change the number of VLANs the switch supports, you must reboot the switch in order to implement the change. Reload automatically saves your configuration changes and reboots the switch from the same OS you have been using:

```
HPswitch(config)# max-vlans 12
Command will take effect after saving configuration and reboot.
HPswitch(config)# reload
Device will be rebooted, do you want to continue [y/n]?  y
Do you want to save current configuration [y/n]?  _
```

**Figure 5-15. Using Reload with Pending Configuration Changes**

## Operating Notes

**Default Boot Source.** The switch reboots from primary flash by default unless you specify the secondary flash.

**Boot Attempts from an Empty Flash Location.** In this case, the switch aborts the attempt and displays

```
Image does not exist
Operation aborted.
```

**Interaction of Primary and Secondary Flash Images with the Current Configuration.** The switch has one startup-config file (page 5-2), which it always uses for reboots, regardless of whether the reboot is from primary or secondary flash. Also, for rebooting purposes, it is not necessary for the OS and the startup-config file to support identical software features. For example, suppose you have just downloaded an OS upgrade that includes new features that are not supported in the OS you used to create the current startup-config file. In this case, the OS simply assigns factory-default values to the parameters controlling the new features. Similarly, If you create a startup-config file

**Switch Memory and Configuration**  
Using Primary and Secondary Flash Image Options

while using a version "Y" of the OS, and then reboot the switch with an earlier OS version "X" that does not include all of the features found in "Y", the OS simply ignores the parameters for any features that it does not support.

# Interface Access, System Information, and Friendly Port Names

---

## Contents

<b>Contents</b> .....	6-1
<b>Overview</b> .....	6-2
<b>Interface Access: Console/Serial Link, Web, and</b>	
<b>Inbound Telnet</b> .....	6-3
Menu: Modifying the Interface Access .....	6-4
CLI: Modifying the Interface Access .....	6-5
<b>Denying Interface Access by Terminating Remote Management</b>	
<b>Sessions</b> .....	6-8
<b>System Information</b> .....	6-9
Menu: Viewing and Configuring System Information .....	6-10
CLI: Viewing and Configuring System Information .....	6-11
Web: Configuring System Parameters .....	6-14
<b>Using Friendly (Optional) Port Names</b> .....	6-15
Configuring and Operating Rules for Friendly Port Names .....	6-15
Configuring Friendly Port Names .....	6-16
Displaying Friendly Port Names with Other Port Data .....	6-18

## Overview

This chapter describes how to:

- View and modify the configuration for switch interface access
- Use the CLI **kill** command to terminate a remote session
- View and modify switch system information

For help on how to actually use the interfaces built into the switch, refer to:

- Chapter 2, “Using the Menu Interface”
- Chapter 3, “Using the Command Line Interface (CLI)”
- Chapter 4, “Using the HP Web Browser Interface”

**Why Configure Interface Access and System Information?** The interface access features in the switch operate properly by default. However, you can modify or disable access features to suit your particular needs. Similarly, you can choose to leave the system information parameters at their default settings. However, modifying these parameters can help you to more easily distinguish one device from another in your network.



# Interface Access: Console/Serial Link, Web, and Inbound Telnet

## Interface Access Features

Feature	Default	Menu	CLI	Web
Inactivity Time	0 Minutes (disabled)	page 6-4	page 6-6	—
Inbound Telnet Access	Enabled	page 6-4	page 6-5	—
Outbound Telnet Access	n/a	—	page 6-6	—
Web Browser Interface Access	Enabled	page 6-4	page 6-6	—
Terminal type	VT-100	—	page 6-6	—
Event Log event types to list (Displayed Events)	All	—	page 6-6	—
Baud Rate	Speed Sense	—	page 6-6	—
Flow Control	XON/XOFF	—	page 6-6	—

In most cases, the default configuration is acceptable for standard operation.

---

### Note

Basic switch security is through passwords. You can gain additional security using IP authorized managers. However if unauthorized access to the switch through in-band means (Telnet or the web browser interface), then you can disallow in-band access (as described in this section) and install the switch in a locked environment.

---

## Menu: Modifying the Interface Access

The menu interface enables you to modify these parameters:

- Inactivity Timeout
- Inbound Telnet Enabled
- Web Agent Enabled

### To Access the Interface Access Parameters:

1. From the Main Menu, Select...
  2. **Switch Configuration...**
    1. **System Information**

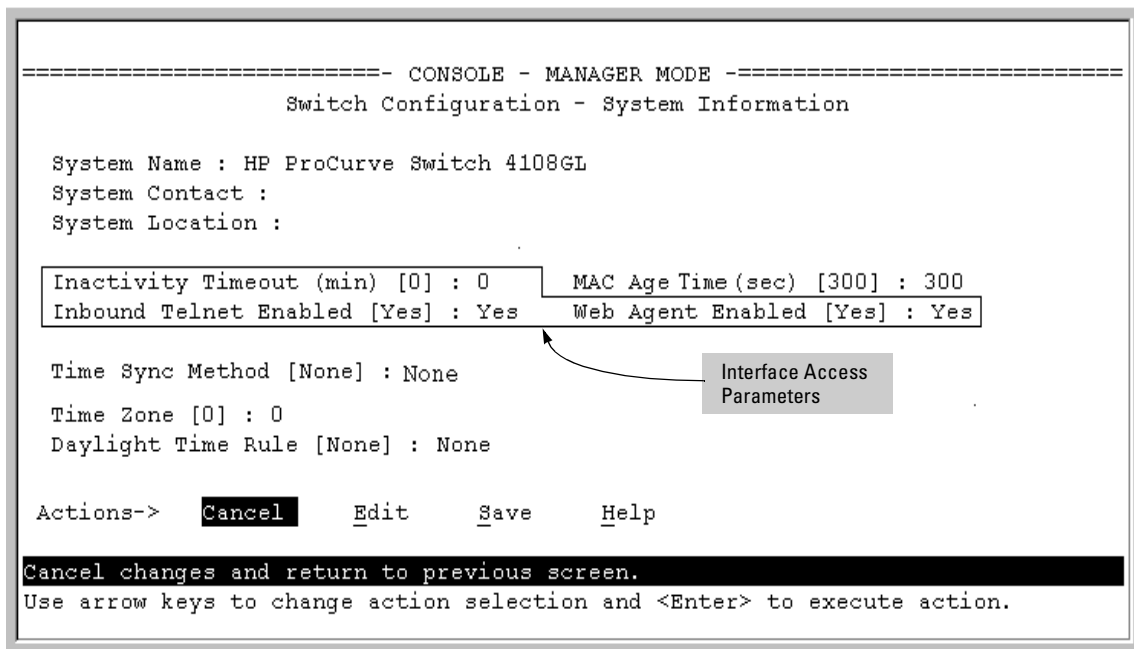

**Figure 6-1. The Default Interface Access Parameters Available in the Menu Interface**

2. Press **[E]** (for **E**dit). The cursor moves to the **System Name** field.
3. Use the arrow keys (**[↓]**, **[↑]**, **[←]**, **[→]**) to move to the parameters you want to change.

Refer to the online help provided with this screen for further information on configuration options for these features.

4. When you have finished making changes to the above parameters, press **[Enter]**, then press **[S]** (for **S**ave).

## CLI: Modifying the Interface Access

### Interface Access Commands Used in This Section

show console	below
[no] telnet-server	below
[no] web-management	page 6-6
console	page 6-6

**Listing the Current Console/Serial Link Configuration.** This command lists the current interface access parameter settings.

**Syntax:** show console

This example shows the switch's default console/serial configuration.

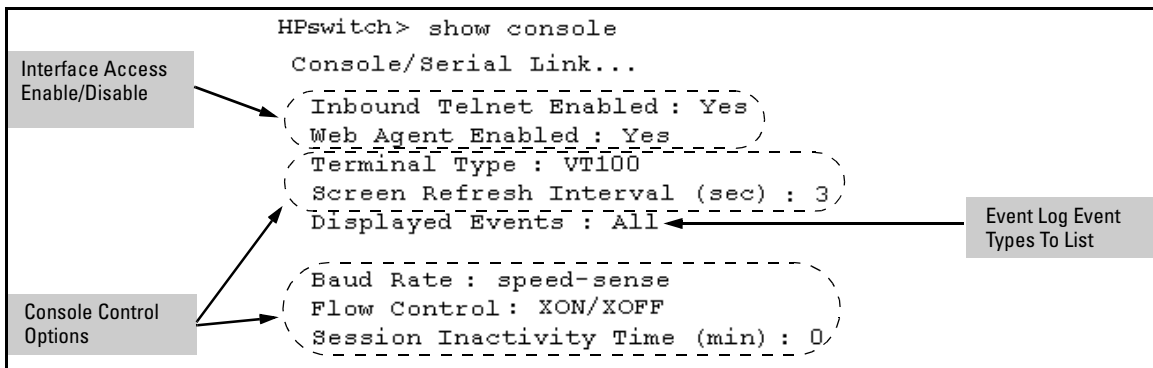

**Figure 6-2. Listing of Show Console Command**

**Reconfigure Inbound Telnet Access.** In the default configuration, inbound Telnet access is enabled.

**Syntax:** [no] telnet-server

To disable inbound Telnet access:

```
HPswitch(config)# no telnet-server
```

To re-enable inbound Telnet access:

```
HPswitch(config)# telnet-server
```

**Outbound Telnet to Another Device.** This feature operates independently of the telnet-server status and enables you to Telnet to another device that has an IP address.

**Syntax:** telnet < ip-address >

For example:

```
HPswitch # telnet 10.28.27.204
```

**Reconfigure Web Browser Access.** In the default configuration, web browser access is enabled.

**Syntax:**[no] web-management

To disable web browser access:

```
HPswitch(config)# no web-management
```

To re-enable web browser access:

```
HPswitch(config)# web-management
```

**Reconfigure the Console/Serial Link Settings.** You can reconfigure one or more console parameters with one console command.

**Syntax:** console  
[terminal <vt100 | ansi>]  
[screen-refresh <1 | 3 | 5 | 10 | 20 | 30 | 45 | 60>]  
[baud-rate  
    <speed-sense | 1200 | 2400 | 4800 | 9600 | 19200 | 38400 | 57600>]  
[flow-control <xon/xoff | none>]  
[inactivity-timer <0 | 1 | 5 | 10 | 15 | 20 | 30 | 60 | 120>]  
[events <none | all | non-info | critical | debug>]

---

**Note**

If you change the Baud Rate or Flow Control settings for the switch, you should make the corresponding changes in your console access device. Otherwise, you may lose connectivity between the switch and your terminal emulator due to differences between the terminal and switch settings for these two parameters.

All console parameter changes except **events** require that you save the configuration with **write memory** and then execute **boot** before the new console configuration will take effect.

---

For example, to use one command to configure the switch with the following:

- VT100 operation
- 19,200 baud
- No flow control
- 10-minute inactivity time
- Critical log events

you would use the following command sequence:

```
HPswitch(config)# console terminal vt100 baud-rate 19200 flow-control none
inactivity-timer 10 events critical
Command will take effect after saving configuration and reboot.
HPswitch(config)# write memory
HPswitch(config)# reload
```

The switch implements the EventLog change immediately. The switch implements the other console changes after executing **write memory** and **reload**.

**Figure 6-3. Example of Executing the Console Command with Multiple Parameters**

You can also execute a series of console commands and then save the configuration and boot the switch. For example:

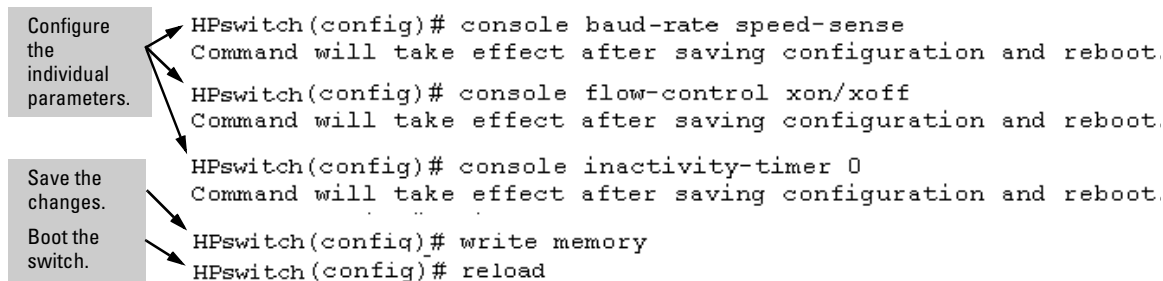

**Figure 6-4. Example of Executing a Series of Console Commands**

## Denying Interface Access by Terminating Remote Management Sessions

The switch supports up to four management sessions. You can use **show ip ssh** to list the current management sessions, and **kill** to terminate a currently running remote session. (**Kill** does not terminate a Console session on the serial port, either through a direct connection or via a modem.)

**Syntax:** kill [<session-number>]

For example, if you are using the switch's serial port for a console session and want to terminate a currently active Telnet session, you would do the following:

```
HPswitch(config)# show ip ssh
SSH Enabled           : Yes

IP Port Number       : 22
Timeout (sec)       : 120
Server Key Size (bits) : 512

Ses Type      Source IP and Port
-----
1  console
2  telnet
3  ssh      15.30.252.195:1531
4  inactive

HPswitch(config)# kill 2
HPswitch(config)# show ip ssh
SSH Enabled           : Yes

IP Port Number       : 22
Timeout (sec)       : 120
Server Key Size (bits) : 512

Ses Type      Source IP and Port
-----
1  console
2  inactive
3  ssh      15.30.252.195:1531
4  inactive
```

The diagram illustrates the effect of the 'kill 2' command. In the first screenshot, session 2 is 'telnet'. An arrow points from a callout box 'Session 2 is an active Telnet session.' to session 2. In the second screenshot, after the 'kill 2' command, session 2 is 'inactive'. An arrow points from a callout box 'The kill 2 command terminates session 2.' to session 2. A curved arrow also points from the 'kill 2' command to the second screenshot.

Figure 6-5. Example of Using the "Kill" Command To Terminate a Remote Session

## System Information

### System Information Features

Feature	Default	Menu	CLI	Web
System Name	<i>switch product name</i>	page 6-10	page 6-12	page 6-14
System Contact	n/a	page 6-10	page 6-12	page 6-14
System Location	n/a	page 6-10	page 6-12	page 6-14
MAC Age Time	300 seconds	page 6-10	page 6-13	—
Time Sync Method	None	See Chapter 8, “Time Protocols”.		
Time Zone	0	page 6-10	page 6-13	—
Daylight Time Rule	None	page 6-10	page 6-13	—
Time	January 1, 1990 at 00:00:00 at last power reset	—	page 6-13	—

Configuring system information is optional, but recommended.

**System Name:** Using a unique name helps you to identify individual devices in stacking environments and where you are using an SNMP network management tool such as HP TopTools for Hubs & Switches.

**System Contact and Location:** This information is helpful for identifying the person administratively responsible for the switch and for identifying the locations of individual switches.

**MAC Age Interval:** The number of seconds a MAC address the switch has learned remains in the switch’s address table before being aged out (deleted). Aging out occurs when there has been no traffic from the device belonging to that MAC address for the configured interval.

**Time Sync Method:** Selects the method (TimeP or SNTP) the switch will use for time synchronization. For more on this topic, refer to Chapter 8, “Time Protocols”.

**Time Zone:** The number of minutes your time zone location is to the West (-) or East (+) of Coordinated Universal Time (formerly GMT). The default 0 means no time zone is configured. For example, Berlin, Germany is in the +1 zone, while Vancouver, Canada is in the -8 zone.

**Daylight Time Rule:** Specifies the daylight savings time rule to apply for your location. The default is **None**. (For more on this topic, see appendix D, “Daylight Savings Time on HP ProCurve Switches.”)

**Time:** Used in the CLI to specify the time of day, the date, and other system parameters.

## Menu: Viewing and Configuring System Information

To access the system information parameters:

1. From the Main Menu, Select...
  2. **Switch Configuration...**
    1. **System Information**

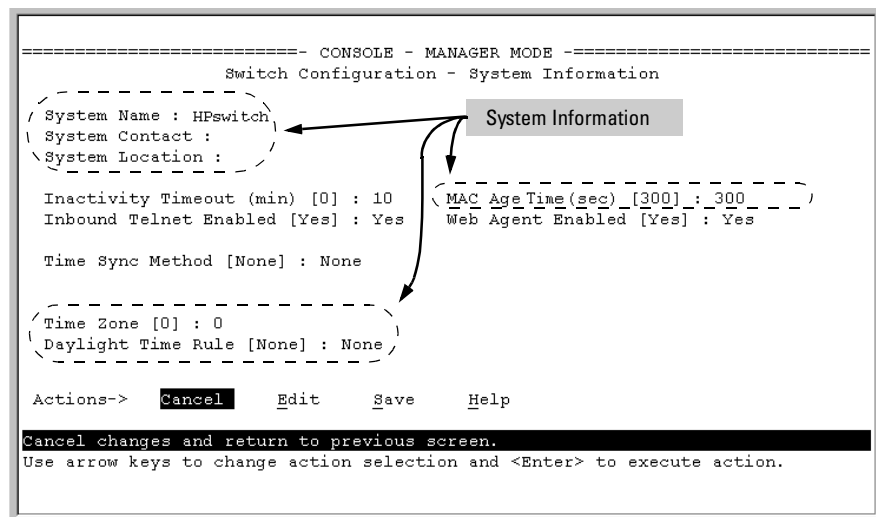

**Figure 6-6. The System Information Configuration Screen (Default Values)**

---

### Note

To help simplify administration, it is recommended that you configure **System Name** to a character string that is meaningful within your system.

2. Press **[E]** (for **E**dit). The cursor moves to the **System Name** field.



3. Refer to the online help provided with this screen for further information on configuration options for these features.
4. When you have finished making changes to the above parameters, press `[Enter]`, then press `[S]` (for **S**ave) and return to the Main Menu.

## CLI: Viewing and Configuring System Information

### System Information Commands Used in This Section

---

show system-information	below
hostname	below
snmp-server [contact] [location]	below
mac-age-time	page 6-13
time	
timezone	page 6-13
daylight-time-rule	page 6-13
date	page 6-13
time	

---

**Listing the Current System Information.** This command lists the current system information settings.

**Syntax:** show system-information

This example shows the switch's default console configuration.

```
HPswitch> show system-information
Status and Counters - General System Information
System Name       : HP ProCurve Switch 4104GL
System Contact    :
System Location   :
MAC Age Interval (sec) : 300
Time Zone         : 0
Daylight Time Rule : None
```

**Figure 6-7. Example of CLI System Information Listing**

**Configure a System Name, Contact, and Location for the Switch.** To help distinguish one switch from another, configure a plain-language identity for the switch.

**Syntax:** hostname <name-string>  
snmp-server [contact <system contact>] [location <system location>]

Both fields allow up to 48 characters. *Blank spaces* are not allowed in the variables for these commands.

For example, to name the switch “Blue” with “Ext-4474” as the system contact, and “North-Data-Room” as the location:

```
HPswitch(config)# hostname Blue
Blue(config)# snmp-server contct Ext-4474 location North-Data-Room
Blue(config)# show system-information

Status and Counters - General System Information
-----
System Name       : Blue
System Contact    : Ext-4474
System Location   : North-Data-Room
-----

MAC Age Interval (sec) : 300

Time Zone         : 0
Daylight Time Rule : None

Firmware revision : G.01.01          Base MAC Addr   : 0001e7-a0ec00
ROM Version       : G.01.01          Serial Number    : S000394041

Up Time           : 14 mins          Memory  - Total  : 25,038,312
CPU Util (%)      : 1                Free      : 20,087,448

IP Mgmt  - Pkts Rx : 0                Packet  - Total  : 832
          Pkts Tx : 0                Buffers  Free    : 783
                                   Lowest   : 768

-- MORE --, next page: Space, next line: Enter, quit: Control-C
```

**Figure 6-8. System Information Listing After Executing the Preceding Commands**

**Reconfigure the Age Time for Learned MAC Addresses.** This command corresponds to the MAC Age Interval in the menu interface, and is expressed in seconds.

**Syntax:** mac-age-time <10 .. 1000000> (seconds)

For example, to configure the age time to seven minutes:

```
HPswitch(config)# mac-age-time 420
```

**Configure the Time Zone and Daylight Time Rule.** These commands:

- Set the time zone you want to use
- Define the daylight time rule for keeping the correct time when daylight-saving-time shifts occur.

**Syntax:** time timezone <-720 .. 840>  
time daylight-time-rule <none | alaska | continental-us-and-canada | middle-europe-and-portugal | southern-hemisphere | western-europe | user-defined>

East of the 0 meridian, the sign is "+". West of the 0 meridian, the sign is "-".

For example, the time zone setting for Berlin, Germany is +60 (zone +1, or 60 minutes), and the time zone setting for Vancouver, Canada is -480 (zone -8, or -480 minutes). To configure the time zone and daylight time rule for Vancouver, Canada:

```
HPswitch(config)# time timezone -480 daylight-time-rule  
continental-us-and-canada
```

**Configure the Time and Date.** The switch uses the time command to configure both the time of day and the date. Also, executing time without parameters lists the switch's time of day and date. Note that the CLI uses a 24-hour clock scheme; that is, hour (*hh*) values from 1 p.m. to midnight are input as 13 - 24, respectively.

**Syntax:** time [*hh:mm[:ss]*] [*mm/dd/[yy]yy*]

For example, to set the switch to 9:45 a.m. on November 17, 2002:

```
HPswitch(config)# time 9:45 11/17/02
```

---

**Note**

Executing **reload** or **boot** resets the time and date to their default startup values.

## Web: Configuring System Parameters

In the web browser interface, you can enter the following system information:

- System Name
- System Location
- System Contact

For access to the MAC Age Interval and the Time parameters, use the menu interface or the CLI.

### **Configure System Parameters in the Web Browser Interface.**

1. Click on the **Configuration** tab.
2. Click on .
3. Enter the data you want in the displayed fields.
4. Implement your new data by clicking on .

To access the web-based help provided for the switch, click on  in the web browser screen.

## Using Friendly (Optional) Port Names

Feature	Default	Menu	CLI	Web
Configure Friendly Port Names	Standard Port Numbering	n/a	page 16	n/a
Display Friendly Port Names	n/a	n/a	page 18	n/a

This feature enables you to assign alphanumeric port names of your choosing to augment automatically assigned numeric port names. This means you can configure meaningful port names to make it easier to identify the source of information listed by some **Show** commands. (Note that this feature *augments* port numbering, but *does not replace* it.)

### Configuring and Operating Rules for Friendly Port Names

- At either the global or context configuration level you can assign a unique name to any port on the switch. You can also assign the same name to multiple ports.
- The friendly port names you configure appear in the output of the **show name [port-list]**, **show config**, and **show interface <port-number>** commands. They do not appear in the output of other show commands or in Menu interface screens. (See “Displaying Friendly Port Names with Other Port Data” on page 6-18.)
- Friendly port names are not a substitute for port numbers in CLI commands or Menu displays.
- Trunking ports together does not affect friendly naming for the individual ports. (If you want the same name for all ports in a trunk, you must individually assign the name to each port.)
- A friendly port name can have up to 64 contiguous alphanumeric characters.
- Blank spaces within friendly port names are not allowed, and if used, cause an **invalid input** error. (The switch interprets a blank space as a name terminator.)
- In a port listing, **not assigned** indicates that the port does not have a name assignment other than its fixed port number.

- To retain friendly port names across reboots, you must save the current running-configuration to the startup-config file after entering the friendly port names. (In the CLI, use the **write memory** command.)

## Configuring Friendly Port Names

**Syntax:** interface [e] <port-list> name <port-name-string> Assigns a port name to <port-list>.

no interface [e] <port-list> name Deletes the port name from <port-list>.

**Configuring a Single Port Name.** Suppose that you have connected port A3 on the switch to Bill Smith's workstation, and want to assign Bill's name and workstation IP address (10.25.101.73) as a port name for port A3:

```
HP4108(config)# int e A3 name Bill_Smith@10.25.101.73
HP4108(config)# write mem
HP4108(config)# show name A3
Port Names
  Port : A3
  Type : 10/100TX
  Name : Bill_Smith@10.25.101.73
```

**Figure 6-9. Example of Configuring a Friendly Port Name**

**Configuring the Same Name for Multiple Ports.** Suppose that you want to use ports A5 through A8 as a trunked link to a server used by a drafting group. In this case you might configure ports A5 through A8 with the name "Draft-Server:Trunk".

```
HPswitch(config)# int e A5-A8 name Draft-Server:Trunk
HPswitch(config)# write mem
HPswitch(config)# show name 5-8

Port Names

Port : A5
Type : 10/100TX
Name : Draft-Server:Trunk

Port : A6
Type : 10/100TX
Name : Draft-Server:Trunk

Port : A7
Type : 10/100TX
Name : Draft-Server:Trunk

Port : A8
Type : 10/100TX
Name : Draft-Server:Trunk
```

**Figure 6-10. Example of Configuring One Friendly Port Name on Multiple Ports**

## Displaying Friendly Port Names with Other Port Data

You can display friendly port name data in the following combinations:

- **show name:** Displays a listing of port numbers with their corresponding friendly port names and also quickly shows you which ports do not have friendly name assignments. (**show name** data comes from the running-config file.)
- **show interface <port-number>:** Displays the friendly port name, if any, along with the traffic statistics for that port. (The friendly port name data comes from the running-config file.)
- **show config:** Includes friendly port names in the per-port data of the resulting configuration listing. (**show config** data comes from the startup-config file.)

### To List All Ports or Selected Ports with Their Friendly Port Names.

This command lists names assigned to a specific port.

**Syntax:** `show name [port-list]` Lists the friendly port name with its corresponding port number and port type. The **show name** alone command lists this data for all ports on the switch.

For example:

```
HPswitch(config)# show name
Port Names
Port Type      Name
-----
A1  10/100TX  not assigned
A2  10/100TX  not assigned
A3  10/100TX  Bill_Smith@10.25.101.73
A4  10/100TX  not assigned
A5  10/100TX  Draft-Server:Trunk
A6  10/100TX  Draft-Server:Trunk
A7  10/100TX  Draft-Server:Trunk
A8  10/100TX  Draft-Server:Trunk
A9  10/100TX  not assigned
A10 10/100TX  not assigned
A11 10/100TX  not assigned
A12 10/100TX  not assigned
.    .
.    .
.    .
```

Figure 6-11. Example of Friendly Port Name Data for All Ports on the Switch



```
HPswitch (config)# show name A2, A3, A5
Port Names
Port : A2
Type : 10/100TX
Name : not assigned
Port : A3
Type : 10/100TX
Name : Bill_Smith@10.25.101.73
Port : A5
Type : 10/100TX
Name : Draft-Server:Trunk
```

**Figure 6-12. Example of Friendly Port Name Data for Specific Ports on the Switch**

**Including Friendly Port Names in Per-Port Statistics Listings.** A friendly port name configured to a port is automatically included when you display the port's statistics output.

**Syntax:** `show interface <port-number>` Includes the friendly port name with the port's traffic statistics listing.

For example, if you configure port A1 with the name "O'Connor\_10.25.101.43", the show interface output for this port appears similar to the following:

```
HPswitch (config)# show interface A1
Status and Counters - Port Counters for port A1
Name : O'Connor@10.25.101.43
Link Status : Up
Bytes Rx : 894,568 Bytes Tx : 2470
Unicast Rx : 1179 Unicast Tx : 13
Bcast/Mcast Rx : 5280 Bcast/Mcast Tx : 13
FCS Rx : 36 Drops Tx : 0
Alignment Rx : 2 Collisions Tx : 0
Runts Rx : 0 Late Colln Tx : 0
Giants Rx : 0 Excessive Colln : 0
Total Rx Errors : 38 Deferred Tx : 0
```

**Figure 6-13. Example of a Friendly Port Name in a Per-Port Statistics Listing**

## Interface Access, System Information, and Friendly Port Names

### Using Friendly (Optional) Port Names

For a given port, if a friendly port name does not exist in the running-config file, the Name line in the above command output appears as:

```
Name : not assigned
```

### To Search the Configuration for Ports with Friendly Port Names.

This option tells you which friendly port names have been saved to the startup-config file. (**show config** does not include ports that have only default settings in the startup-config file.)

**Syntax:** show config includes friendly port names in a listing of all interfaces (ports) configured with non-default settings. Excludes ports that have neither a friendly port name nor any other non-default configuration settings.

For example, if you configure port A1 with a friendly port name:

```
HPswitch(config)# int e A1 name Print_Server@10.25.101.43
HPswitch(config)# write mem
HPswitch(config)# int e A2 name Herbert's_PC
HPswitch(config)# show config

Startup configuration:
; J4865A Configuration Editor; Created on release #G.05.01
hostname "HPswitch"
time daylight-time-rule None
no cdp run
interface A1
  name "Print_Server@10.25.101.43"
exit
snmp-server community "public" Unrestricted
vlan 1
  name "DEFAULT_VLAN"
  untagged 1-24
  ip address dhcp-bootp
  exit
no aaa port-access authenticator active
```

This command sequence saves the friendly port name for port A1 in the startup-config file, but does not do so for the name entered for port A2.

Listing includes friendly port name for port A1 only.

In this case, **show config** lists only port A1. Executing **write mem** after entering the name for port A2, and then executing **show config** again would result in a listing that includes

**Figure 6-14. Example Listing of the Startup-Config File with a Friendly Port Name Configured (and Saved)**

# Configuring IP Addressing

---

## Contents

<b>Overview</b> .....	7-2
<b>IP Configuration</b> .....	7-3
Just Want a Quick Start with IP Addressing? .....	7-4
IP Addressing with Multiple VLANs .....	7-4
IP Addressing in a Stacking Environment .....	7-5
Menu: Configuring IP Address, Gateway, and Time-To-Live (TTL) ..	7-5
CLI: Configuring IP Address, Gateway, and Time-To-Live (TTL) ....	7-7
Web: Configuring IP Addressing .....	7-9
How IP Addressing Affects Switch Operation .....	7-9
DHCP/Bootp Operation .....	7-10
Network Preparations for Configuring DHCP/Bootp .....	7-13
<b>IP Preserve: Retaining VLAN-1 IP Addressing Across Configuration</b>	
<b>File Downloads</b> .....	7-14
<b>Globally Assigned IP Network Addresses</b> .....	7-18

## Overview

You can configure IP addressing through all of the switch's interfaces. You can also easily edit a switch configuration file to allow downloading the file to multiple Series 4100GL switches without overwriting each switch's unique gateway and VLAN 1 IP addressing.

**Why Configure IP Addressing?** In its factory default configuration, the switch operates as a multiport learning bridge with network connectivity provided by the ports on the switch. However, to enable specific management access and control through your network, you will need IP addressing. Table 7-1 on page 7-10 shows the switch features that depend on IP addressing to operate.

# IP Configuration

## IP Configuration Features

Feature	Default	Menu	CLI	Web
IP Address and Subnet Mask	DHCP/Bootp	page 7-5	page 7-7	page 7-9
Default Gateway Address	none	page 7-5	page 7-7	page 7-9
Packet Time-To-Live (TTL)	64 seconds	page 7-5	page 7-7	n/a
Time Server (Timep)	DHCP	page 7-5	page 7-7	n/a

**IP Address and Subnet Mask.** Configuring the switch with an IP address expands your ability to manage the switch and use its features. By default, the switch is configured to automatically receive IP addressing on the default VLAN from a DHCP/Bootp server that has been configured correctly with information to support the switch. (Refer to “DHCP/Bootp Operation” on page 7-10 for information on setting up automatic configuration from a server.) However, if you are not using a DHCP/Bootp server to configure IP addressing, use the menu interface or the CLI to manually configure the initial IP values. After you have network access to a device, you can use the web browser interface to modify the initial IP configuration if needed.

For information on how IP addressing affects switch performance, refer to “How IP Addressing Affects Switch Operation” on page 7-9.

**Default Gateway Operation.** The default gateway is required when a router is needed for tasks such as reaching off-subnet destinations or forwarding traffic across multiple VLANs. The gateway value is the IP address of the next-hop gateway node for the switch, which is used if the requested destination address is not on a local subnet/VLAN. If the switch does not have a manually-configured default gateway and DHCP/Bootp is configured on the primary VLAN, then the default gateway value provided by the DHCP or Bootp server will be used. If the switch has a manually configured default gateway, then the switch uses this gateway, even if a different gateway is received via DHCP or Bootp on the primary VLAN. (This is also true for TimeP and a non-default Time-To-Live.) See “Notes” on page 7-4 and “The Primary VLAN” on page 11-6.

**Packet Time-To-Live (TTL)** . This parameter specifies how long in seconds an outgoing packet should exist in the network. In most cases, the default setting (64 seconds) is adequate.

## Just Want a Quick Start with IP Addressing?

If you just want to give the switch an IP address so that it can communicate on your network, or if you are not using VLANs, HP recommends that you use the Switch Setup screen to quickly configure IP addressing. To do so, do one of the following:

- Enter setup at the CLI Manager level prompt.  

```
HPswitch# setup
```
- Select **8. Run Setup** in the Main Menu of the menu interface.

For more on using the Switch Setup screen, see the *Installation and Getting Started Guide* you received with the switch.

## IP Addressing with Multiple VLANs

In the factory-default configuration, the switch has one, permanent default VLAN (named DEFAULT\_VLAN) that includes all ports on the switch. Thus, when only the default VLAN exists in the switch, if you assign an IP address and subnet mask to the switch, you are actually assigning the IP addressing to the DEFAULT\_VLAN.

---

### Notes

- If multiple VLANs are configured, then each VLAN can have its own IP address. This is because each VLAN operates as a separate broadcast domain and requires a unique IP address and subnet mask. A default gateway (IP) address for the switch is optional, but recommended.
- In the factory-default configuration, the default VLAN (named DEFAULT\_VLAN) is the switch's *primary* VLAN. The switch uses the primary VLAN for learning the default gateway address, (packet) Time-To-Live (TTL), and TimeP via DHCP or Bootp. (Other VLANs can also use DHCP or BootP to acquire IP addressing. However, the switch's gateway, TTL, and TimeP values will be acquired through the primary VLAN only.) For more on VLANs, refer to "Port-Based Virtual LANs (Static VLANs)" on page 11-3.
- The IP addressing used in the switch should be compatible with your network. That is, the IP address must be unique and the subnet mask must be appropriate for your IP network.
- If you plan to connect to other networks that use globally administered IP addresses, refer to "Globally Assigned IP Network Addresses" on page 7-18.

- If you change the IP address through either Telnet access or the web browser interface, the connection to the switch will be lost. You can reconnect by either restarting Telnet with the new IP address or entering the new address as the URL in your web browser.
- 

## IP Addressing in a Stacking Environment

If you are installing the switch into an HP Procurve stack management environment, entering an IP address may not be required. See chapter 14, 'HP Procurve Stack Management' for more information.

## Menu: Configuring IP Address, Gateway, and Time-To-Live (TTL)

Do one of the following:

- To manually enter an IP address, subnet mask, set the **IP Config** parameter to **Manual** and then manually enter the IP address and subnet mask values you want for the switch.
- To use DHCP or Bootp, use the menu interface to ensure that the **IP Config** parameter is set to **DHCP/Bootp**, then refer to "DHCP/Bootp Operation" on page 7-10.

### To Configure IP Addressing.

1. From the Main Menu, Select.
  2. **Switch Configuration ...**
  5. **IP Configuration**

---

### Note

If multiple VLANs are configured, a screen showing all VLANs appears instead of the following screen.

---

For descriptions of these parameters, see the online Help for this screen.

Before using the DHCP/Bootp option, refer to "DHCP/Bootp Operation" on page 7-10.

```
----- CONSOLE - MANAGER MODE -----  
Switch Configuration - Internet (IP) Service  
  
Default Gateway :  
Default TTL      : 64  
  
IP Config [DHCP/Bootp] : Manual  
IP Address       : 15.30.248.184  
Subnet Mask      : 255.255.248.0  
  
Actions->  Cancel   Edit   Save   Help  
Cancel changes and return to previous screen.  
Use arrow keys to change action selection and <Enter> to execute action.
```

**Figure 5-1. Example of the IP Service Configuration Screen without Multiple VLANs Configured**

2. Press **[E]** (for **E**dit).
3. If the switch needs to access a router, for example, to reach off-subnet destinations, select the **Default Gateway** field and enter the IP address of the gateway router.
4. If you need to change the packet Time-To-Live (TTL) setting, select **Default TTL** and type in a value between 2 and 255 (seconds).
5. To configure IP addressing, select **IP Config** and do one of the following:
  - If you want to have the switch retrieve its IP configuration from a DHCP or Bootp server, at the **IP Config** field, keep the value as **DHCP/Bootp** and go to step 8.
  - If you want to manually configure the IP information, use the Space bar to select **Manual** and use the **[Tab]** key to move to the other IP configuration fields.
6. Select the **IP Address** field and enter the IP address for the switch.
7. Select the **SubnetMask** field and enter the subnet mask for the IP address.
8. Press **[Enter]**, then **[S]** (for **S**ave).



## CLI: Configuring IP Address, Gateway, and Time-To-Live (TTL)

### IP Commands Used in This Section

show ip	page 7-7
vlan <vlan-id> ip address	page 7-8
ip default-gateway	page 7-8
ip ttl	page 7-9

**Viewing the Current IP Configuration.** The following command displays the IP addressing for each VLAN configured in the switch. If only the DEFAULT\_VLAN exists, then its IP configuration applies to all ports in the switch. Where multiple VLANs are configured, the IP addressing is listed per VLAN. The display includes switch-wide packet time-to-live, and (if configured) the switch's default gateway and Timep configuration.

**Syntax:** show ip

For example, in the factory-default configuration (no IP addressing assigned), the switch's IP addressing appears as:

```

The Default IP Configuration on a Switch 4108GL
HP4108> show ip
Internet (IP) Service
  Default Gateway :
  Default TTL      : 64

TimeP Config : DHCP      TimeP Poll Interval (min) : 720

VLAN          | IP Config  IP Address      Subnet Mask
-----+-----
DEFAULT_VLAN | DHCP/Bootp
  
```

**Figure 5-2. Example of the Switch's Default IP Addressing**

With multiple VLANs and some other features configured, **show ip** provides additional information:

```
A Switch 4108GL with IP Addressing and VLANs Configured
HP4108# show ip
Internet (IP) Service
  Default Gateway : 10.28.227.1
  Default TTL     : 64
  VLAN           | IP Config | IP Address      | Subnet Mask
  -----+-----+-----+-----
  DEFAULT_VLAN | Manual   | 10.28.227.101  | 255.255.248.0
  VLAN_2       | Disabled
```

Figure 5-3. Example of Show IP Listing with Non-Default IP Addressing Configured

**Configure an IP Address and Subnet Mask.** The following command includes both the IP address and the subnet mask. You must either include the ID of the VLAN for which you are configuring IP addressing or go to the context configuration level for that VLAN. (If you are not using VLANs on the switch—that is, if the only VLAN is the default VLAN—then the VLAN ID is always “1”.)

---

**Note**

The default IP address setting for the DEFAULT\_VLAN is **DHCP/Bootp**. On additional VLANs you create, the default IP address setting is **Disabled**.

**Syntax:** vlan <vlan-id> ip address <ip-address/mask-length>  
or  
vlan <vlan-id> ip address <ip-address> <mask-bits>  
or  
vlan <vlan-id> ip address dhcp-bootp

This example configures IP addressing on the default VLAN with the subnet mask specified in mask bits.

```
HPswitch(config)# vlan 1 ip address 10.28.227.103/  
255.255.255.0
```

This example configures the same IP addressing as the preceding example, but specifies the subnet mask by mask length.

```
HPswitch(config)# vlan 1 ip address 10.28.227.103/24
```

**Configure the Optional Default Gateway.** Using the Global configuration level, you can assign one default gateway to the switch.

**Syntax:** ip default-gateway <ip-address>

For example:

```
HPswitch(config)# ip default-gateway 10.28.227.115
```

**Configure Time-To-Live (TTL).** Use this command at the Global config prompt to set the time that a packet outbound from the switch can exist on the network. The default setting is 64 seconds.

**Syntax:** ip ttl <number-of-seconds>

```
HP4108(config)# ip ttl 60
```

In the CLI, you can execute this command only from the global configuration level. The TTL range is 2 - 255 seconds.

## Web: Configuring IP Addressing

You can use the web browser interface to access IP addressing only if the switch already has an IP address that is reachable through your network.

1. Click on the Configuration tab.
2. Click on [IP Configuration](#).
3. If you need further information on using the web browser interface, click on [?](#) to access the web-based help available for the Switch 2512/2524.

## How IP Addressing Affects Switch Operation

Without an IP address and subnet mask compatible with your network, the switch can be managed only through a direct terminal device connection to the Console RS-232 port. You can use direct-connect console access to take advantage of features that do not depend on IP addressing. However, to realize the full performance capabilities HP proactive networking offers through the switch, configure the switch with an IP address and subnet mask compatible with your network. The following table lists the general features available with and without a network-compatible IP address configured.

**Table 7-1. Features Available With and Without IP Addressing on the Switch**

Features Available Without an IP Address	Additional Features Available with an IP Address and Subnet Mask
<ul style="list-style-type: none"><li>• Direct-connect access to the CLI and the menu interface.</li><li>• Stacking Candidate or Stack Member</li><li>• DHCP or Bootp support for automatic IP address configuration, and DHCP support for automatic Timep server IP address configuration</li><li>• Spanning Tree Protocol</li><li>• Port settings and port trunking</li><li>• Console-based status and counters information for monitoring switch operation and diagnosing problems through the CLI or menu interface.</li><li>• VLANs and GVRP</li><li>• Serial downloads of operating system (OS) updates and configuration files (Xmodem)</li><li>• Link test</li><li>• Port monitoring</li><li>• Password authentication</li><li>• Authorized IP manager security</li></ul>	<ul style="list-style-type: none"><li>• HP web browser interface access, with configuration, security, and diagnostic tools, plus the Alert Log for discovering problems detected in the switch along with suggested solutions</li><li>• SNMP network management access such as HP TopTools network configuration, monitoring, problem-finding and reporting, analysis, and recommendations for changes to increase control and uptime</li><li>• TACACS+, RADIUS, SSH, and 802.1x authentication</li><li>• CDP support</li><li>• Stacking Commander*</li><li>• Telnet access to the CLI or the menu interface</li><li>• IGMP</li><li>• Timep server configuration</li><li>• TFTP download of configurations and OS updates</li><li>• Ping test</li></ul>

\*Although a Commander can operate without an IP address, doing so makes it unavailable for in-band access in an IP network.

## DHCP/Bootp Operation

**Overview.** DHCP/Bootp is used to provide configuration data from a DHCP or Bootp server to the switch. This data can be the IP address, subnet mask, default gateway, Timep Server address, and TFTP server address. If a TFTP server address is provided, this allows the switch to TFTP a previously saved configuration file from the TFTP server to the switch. With either DHCP or Bootp, the servers must be configured prior to the switch being connected to the network.

---

### Note

The Series 4100GL switches are compatible with both DHCP and Bootp servers.

**The DHCP/Bootp Process.** Whenever the **IP Config** parameter in the switch or in an individual VLAN in the switch is configured to **DHCP/Bootp** (the default), or when the switch is rebooted with this configuration:

1. DHCP/Bootp requests are automatically broadcast on the local network. (The switch sends one type of request to which either a DHCP or Bootp server can respond.)
2. When a DHCP or Bootp server receives the request, it replies with a previously configured IP address and subnet mask for the switch. The switch also receives an IP Gateway address if the server has been configured to provide one. In the case of Bootp, the server must first be configured with an entry that has the MAC address of the switch. (To determine the switch's MAC address, see appendix D, "MAC Address Management". The switch properly handles replies from either type of server. If multiple replies are returned, the switch tries to use the first reply.)

---

**Note**

---

If you manually configure a gateway on the switch, it will ignore any gateway address received via DHCP or Bootp.

If the switch is initially configured for DHCP/Bootp operation (the default), or if it is rebooted with this configuration, it immediately begins sending request packets on the network. If the switch does not receive a reply to its DHCP/Bootp requests, it continues to periodically send request packets, but with decreasing frequency. Thus, if a DHCP or Bootp server is not available or accessible to the switch when DHCP/Bootp is first configured, the switch may not immediately receive the desired configuration. After verifying that the server has become accessible to the switch, reboot the switch to re-start the process immediately.

**DHCP Operation.** A significant difference between a DHCP configuration and a Bootp configuration is that an IP address assignment from a DHCP server is automatic. Depending on how the DHCP server is configured, the switch may receive an ip address that is temporarily leased. Periodically the switch may be required to renew its lease of the IP configuration. Thus, the IP addressing provided by the server may be different each time the switch reboots or renews its configuration from the server. However, you can fix the address assignment for the switch by doing either of the following:

- Configure the server to issue an "infinite" lease.
- Using the switch's MAC address as an identifier, configure the server with a "Reservation" so that it will always assign the same IP address to the switch. (For MAC address information, refer to appendix D, "MAC Address Management".)

For more information on either of these procedures, refer to the documentation provided with the DHCP server.

**Bootp Operation.** When a Bootp server receives a request it searches its Bootp database for a record entry that matches the MAC address in the Bootp request from the switch. If a match is found, the configuration data in the associated database record is returned to the switch. For many Unix systems, the Bootp database is contained in the **/etc/bootptab** file. In contrast to DHCP operation, Bootp configurations are always the same for a specific receiving device. That is, the Bootp server replies to a request with a configuration previously stored in the server and designated for the requesting device.

**Bootp Database Record Entries.** A minimal entry in the Bootp table file **/etc/bootptab** to update an IP address and subnet mask to the switch or a VLAN configured in the switch would be similar to this entry:

```
j4108switch:\
  ht=ether:\
  ha=0030c1123456:\
  ip=10.66.77.88:\
  sm=255.255.248.0:\
  gw=10.66.77.1:\
  hn:\
  vm=rfc1048
```

An entry in the Bootp table file **/etc/bootptab** to tell the switch or VLAN where to obtain a configuration file download would be similar to this entry:

```
j4108switch:\
  ht=ether:\
  ha=0030c1123456:\
  ip=10.66.77.88:\
  sm=255.255.248.0:\
  gw=10.66.77.1:\
  lg=10.22.33.44:\
  T144="switch.cfg" :\
  vm=rfc1048
```

*where:*

- |             |   |
|-------------|---|
| j4108switch | is a user-defined symbolic name to help you find the correct section of the bootptab file. If you have multiple switches that will be using Bootp to get their IP configuration, you should use a unique symbolic name for each switch. |
| ht          | is the "hardware type". For the Series 4100GL switches, set this to <b>ether</b> (for Ethernet). <i>This tag must precede the ha tag.</i>   |
| ha          | is the "hardware address". Use the switch's (or VLAN's) 12-digit MAC address.   |
| ip          | is the IP address to be assigned to the switch (or VLAN).   |
| sm          | is the subnet mask of the subnet in which the switch (or VLAN) is installed.  |

gw	is the IP address of the default gateway.
lg	TFTP server address (source of final configuration file)
T144	is the vendor-specific “tag” identifying the configuration file to download.
vm	is a required entry that specifies the Bootp report format. For the Series 4100GL switches, set this parameter to <b>rfc1048</b> .

---

**Note**

---

The above Bootp table entry is a sample that will work for the Series 4100GL switches when the appropriate addresses and file names are used.

## Network Preparations for Configuring DHCP/Bootp

In its default configuration, the switch is configured for DHCP/Bootp operation. However, the DHCP/Bootp feature will not acquire IP addressing for the switch unless the following tasks have already been completed:

- For Bootp operation:
  - A Bootp database record has already been entered into an appropriate Bootp server.
  - The necessary network connections are in place
  - The Bootp server is accessible from the switch
- For DHCP operation:
  - A DHCP scope has been configured on the appropriate DHCP server.
  - The necessary network connections are in place
  - A DHCP server is accessible from the switch

---

**Note**

---

Designating a primary VLAN other than the default VLAN affects the switch's use of information received via DHCP/Bootp. For more on this topic, see “The Primary VLAN” on page 11-6.

After you reconfigure or reboot the switch with DHCP/Bootp enabled in a network providing DHCP/Bootp service, the switch does the following:

- Receives an IP address and subnet mask and, if configured in the server, a gateway IP address and the address of a Tftp server.
- If the DHCP/Bootp reply provides information for downloading a configuration file, the switch uses TFTP to download the file from the designated source, then reboots itself. (This assumes that the switch or VLAN has connectivity to the TFTP file server specified in the reply, that the configuration file is correctly named, and that the configuration file exists in the TFTP directory.)

# IP Preserve: Retaining VLAN-1 IP Addressing Across Configuration File Downloads

IP Preserve enables you to copy a configuration file to multiple Series 4100GL switches while retaining the individual IP address and subnet mask on VLAN 1 in each switch, and the Gateway IP address assigned to the switch. This enables you to distribute the same configuration file to multiple switches without overwriting their individual IP addresses.

## Operating Rules for IP Preserve

When **ip preserve** is entered as the last line in a configuration file stored on a TFTP server:

- If the switch's current IP address for VLAN 1 was not configured by DHCP/Bootp, IP Preserve retains the switch's current IP address, subnet mask, and IP gateway address when the switch downloads the file and reboots. The switch adopts all other configuration parameters in the configuration file into the startup-config file.
- If the switch's current IP addressing for VLAN 1 is from a DHCP server, IP Preserve is suspended. In this case, whatever IP addressing the configuration file specifies is implemented when the switch downloads the file and reboots. If the file includes DHCP/Bootp as the IP addressing source for VLAN 1, the switch will configure itself accordingly and use DHCP/Bootp. If instead, the file includes a dedicated IP address and subnet mask for VLAN 1 and a specific gateway IP address, then the switch will implement these settings in the startup-config file.
- The **ip preserve** statement does not appear in **show config** listings. To verify IP Preserve in a configuration file, open the file in a text editor and view the last line. For an example of implementing IP Preserve in a configuration file, see figure 7-4, below.

To set up IP Preserve, enter the **ip preserve** statement at the end of a configuration file. (Note that you do not execute IP Preserve by entering a command from the CLI).



```

; J4865A Configuration Editor; Created on release #G.05.01
hostname "HP4108"
time daylight-time-rule None
cdp run
.
.
.
password manager
password operator
ip preserve
    
```

Entering "ip preserve" in the last line of a configuration file implements IP Preserve when the file is downloaded to the switch and the switch reboots.

**Figure 7-4. Example of Implementing IP Preserve in a Switch 4108GL Configuration File**

For example, consider Figure 7-5:

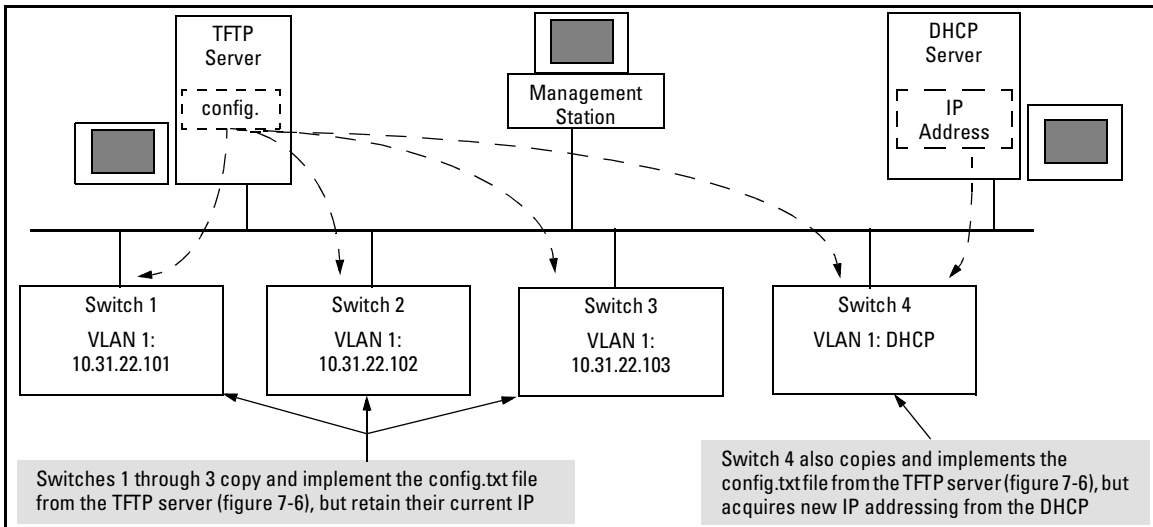

**Figure 7-5. Example of IP Preserve Operation with Multiple Series 4100GL Switches**

If you apply the following configuration file to figure 7-5, switches 1 - 3 will retain their manually assigned IP addressing and switch 4 will be configured to acquire its IP addressing from a DHCP server.

## Configuring IP Addressing

### IP Preserve: Retaining VLAN-1 IP Addressing Across Configuration File Downloads

```
; J4865A Configuration Editor; Created on release # G.05.01
hostname "HP4108"
time daylight-time-rule None
cdp run
interface A11
  no lACP
exit
interface A12
  no lACP
exit
trunk A11-A12 Trk1 Trunk
ip default-gateway 10.33.32.1
snmp-server community "public" Unrestricted
vlan 1
  name "DEFAULT_VLAN"
  ip address dhcp-bootp
  exit
password manager
password operator
ip preserve
```

Using figure 7-5, above, switches 1 - 3 ignore these entries because the file implements IP Preserve and their current IP addressing was not acquired through DHCP/Bootp.

Switch 4 ignores IP Preserve and implements the DHCP/Bootp addressing and IP Gateway specified in this file (because its last IP addressing was acquired from a DHCP/Bootp server).

IP Preserve Command

**Figure 7-6. Configuration File in TFTP Server, with DHCP/Bootp Specified as the IP Addressing Source**

If you apply this configuration file to figure 7-5, switches 1 - 3 will still retain their manually assigned IP addressing. However, switch 4 will be configured with the IP addressing included in the file.

```

; J4865A Configuration Editor; Created on release #G.05.01
hostname "HP4108"
time daylight-time-rule None
cdp run
interface A11
    no lACP
exit
interface A12
    no lACP
exit
trunk A11-A12 Trk1 Trunk
ip default-gateway 10.33.32.1
snmp-server community "public" Unrestricted
vlan 1
    name "DEFAULT_VLAN"
    forbid A3
    untagged A1,A7-A10,A13-A14,Trk1
    tagged A4-A6
    no untagged A2-A3
    ip address 10.31.22.255 255.255.248.0
    exit
password manager
password operator
ip preserve

```

Because switch 4 (figure 7-5) received its most recent IP addressing from a DHCP/Bootp server, the switch ignores the **ip preserve** command and implements the IP addressing included in this file.

**Figure 7-7. Configuration File in TFTP Server, with Dedicated IP Addressing Instead of DHCP/Bootp**

To summarize the IP Preserve effect on IP addressing:

- If the switch received its most recent VLAN 1 IP addressing from a DHCP/Bootp server, it ignores the IP Preserve command when it downloads the configuration file, and implements whatever IP addressing instructions are in the configuration file.
- If the switch did not receive its most recent VLAN 1 IP addressing from a DHCP/Bootp server, it retains its current IP addressing when it downloads the configuration file.
- The content of the downloaded configuration file determines the IP addresses and subnet masks for other VLANs.

## Globally Assigned IP Network Addresses

If you intend to connect your network to other networks that use globally administered IP addresses, Hewlett-Packard strongly recommends that you use IP addresses that have a network address assigned to you. There is a formal process for assigning unique IP addresses to networks worldwide. For more information:

Please contact your internet service provider (ISP).

If you need more information than your ISP can provide, contact one of the following organizations:

Country	Phone Number/E-Mail/URL	Organization Name/Address
United States/ Countries not in Europe or Asia/Pacific	1-310-823-9358 icann@icann.org <a href="http://www.icann.org">http://www.icann.org</a>	The Internet Corporation for Assigned Names and Numbers (ICANN) 4676 Admiralty Way, Suite 330 Marina Del Rey, CA 90292 USA
Europe	+31 20 535 4444 ncc@ripe.net <a href="http://www.ripe.net">http://www.ripe.net</a>	RIPE NCC Singel 258 1016 AB Amsterdam The Netherlands
Asia/Pacific	+61-7-3367-0490 info@apnic.net <a href="http://www.apnic.net">http://www.apnic.net</a>	Attention: IN-ADDR.ARPA Registration Asia Pacific Network Information Center Level 1, 33 Park Road PO Box 2131 Milton, QLD 4064 Australia

For more information, refer to the latest edition of *Internetworking with TCP/IP: Principles, Protocols and Architecture* by Douglas E. Comer (Prentice-Hall, Inc., publisher).

# Time Protocols

---

## Contents

<b>Overview</b> .....	8-2
TimeP Time Synchronization .....	8-2
SNTP Time Synchronization .....	8-2
<b>Overview: Selecting a Time Synchronization Protocol or Turning Off Time Protocol Operation</b> .....	8-3
General Steps for Running a Time Protocol on the Switch: .....	8-3
Disabling Time Synchronization .....	8-4
<b>SNTP: Viewing, Selecting, and Configuring</b> .....	8-4
Menu: Viewing and Configuring SNTP .....	8-5
CLI: Viewing and Configuring SNTP .....	8-8
Viewing the Current SNTP Configuration .....	8-8
Configuring (Enabling or Disabling) the SNTP Mode .....	8-9
<b>TimeP: Viewing, Selecting, and Configuring</b> .....	8-13
Menu: Viewing and Configuring TimeP .....	8-14
CLI: Viewing and Configuring TimeP .....	8-16
Viewing the Current TimeP Configuration .....	8-16
Configuring (Enabling or Disabling) the TimeP Mode .....	8-17
<b>SNTP Unicast Time Polling with Multiple SNTP Servers</b> .....	8-20
Address Prioritization .....	8-21
Adding and Deleting SNTP Server Addresses .....	8-21
Menu Interface Operation with Multiple SNTP Server Addresses Configured .....	8-22
<b>SNTP Messages in the Event Log</b> .....	8-23

## Overview

This chapter describes:

- SNTP Time Protocol Operation
- Timep Time Protocol Operation

Using time synchronization ensures a uniform time among interoperating devices. This helps you to manage and troubleshoot switch operation by attaching meaningful time data to event and error messages.

The switch offers TimeP and SNTP (Simple Network Time Protocol) and a **timesync** command for changing the time protocol selection (or turning off time protocol operation).

---

### Notes

- Although you can create and save configurations for both time protocols without conflicts, the switch allows only one active time protocol at any time.
  - In the factory-default configuration, the time synchronization option is set to TimeP, with the TimeP mode itself set to **Disabled**.
- 

## TimeP Time Synchronization

You can either manually assign the switch to use a TimeP server or use DHCP to assign the TimeP server. In either case, the switch can get its time synchronization updates from only one, designated Timep server. This option enhances security by specifying which time server to use.

## SNTP Time Synchronization

SNTP provides two operating modes:

- **Broadcast Mode:** The switch acquires time updates by accepting the time value from the first SNTP time broadcast detected. (In this case, the SNTP server must be configured to broadcast time updates to the network broadcast address. Refer to the documentation provided with your SNTP server application.) Once the switch detects a partic-

ular server, it ignores time broadcasts from other SNTP servers unless the configurable **Poll Interval** expires three consecutive times without an update received from the first-detected server.

---

**Note**

To use Broadcast mode, the switch and the SNTP server must be in the same subnet.

---

- **Unicast Mode:** The switch requests a time update from the configured SNTP server. (You can configure one server using the menu interface, or up to three servers using the CLI `sntp server` command.) This option provides increased security over the Broadcast mode by specifying which time server to use instead of using the first one detected through a broadcast.
- 

---

## Overview: Selecting a Time Synchronization Protocol or Turning Off Time Protocol Operation

### General Steps for Running a Time Protocol on the Switch:

1. Select the time synchronization protocol: **SNTP** or **TimeP** (the default).
2. Enable the protocol. The choices are:
  - SNTP: **Broadcast** or **Unicast**
  - TimeP: **DHCP** or **Manual**
3. Configure the remaining parameters for the time protocol you selected.

The switch retains the parameter settings for both time protocols even if you change from one protocol to the other. Thus, if you select a time protocol, the switch uses the parameters you last configured for the selected protocol.

## Time Protocols

### SNTP: Viewing, Selecting, and Configuring

Note that simply selecting a time synchronization protocol does not enable that protocol on the switch unless you also enable the protocol itself (step 2, above). For example, in the factory-default configuration, TimeP is the selected time synchronization method. However, because TimeP is disabled in the factory-default configuration, no time synchronization protocol is running.

### Disabling Time Synchronization

You can use either of the following methods to disable time synchronization without changing the Timep or SNTP configuration:

- In the System Information screen of the Menu interface, set the **Time Synch Method** parameter to **None**, then press **[Enter]**, then **[S]** (for **Save**).
- In the Global config level of the CLI, execute **no timesync**.

---

## SNTP: Viewing, Selecting, and Configuring

SNTP Feature	Default	Menu	CLI	Web
view the SNTP time synchronization configuration	n/a	page 8-5	page 8-8	—
select SNTP as the time synchronization method	timep	page 8-6	page 8-9 ff.	—
disable time synchronization	timep	page 8-6	page 8-12	—
enable the SNTP mode (Broadcast, Unicast, or Disabled)	disabled			—
broadcast	n/a	page 8-6	page 8-9	—
unicast	n/a	page 8-6	page 8-10	—
none/disabled	n/a	page 8-6	page 8-13	—
configure an SNTP server address (for Unicast mode only)	none	page 8-6	page 8-10 ff.	—
change the SNTP server version (for Unicast mode only)	3	page 8-7	page 8-12	—
change the SNTP poll interval	720 seconds	page 8-7	page 8-12	—



**Table 8-1.SNTP Parameters**

SNTP Parameter	Operation
<b>Time Sync Method</b>	Used to select either SNTP, TIMEP, or None as the time synchronization method.
<b>SNTP Mode</b>	
<b>Disabled</b>	The Default. SNTP does not operate, even if specified by the Menu interface <b>Time Sync Method</b> parameter or the CLI <b>timesync</b> command.
<b>Unicast</b>	Directs the switch to poll a specific server for SNTP time synchronization. Requires at least one server address.
<b>Broadcast</b>	Directs the switch to acquire its time synchronization from data broadcast by any SNTP server to the network broadcast address. The switch uses the first server detected and ignores any others. However, if the Poll Interval expires three times without the switch detecting a time update from the original server, it the switch accepts a broadcast time update from the next server it detects.
<b>Poll Interval (seconds)</b>	In Unicast Mode: Specifies how often the switch polls the designated SNTP server for a time update. In Broadcast Mode: Specifies how often the switch polls the network broadcast address for a time update.
<b>Server Address</b>	Used only when the <b>SNTP Mode</b> is set to <b>Unicast</b> . Specifies the IP address of the SNTP server that the switch accesses for time synchronization updates. You can configure up to three servers; one using the menu or CLI, and two more using the CLI. See “SNTP Unicast Time Polling with Multiple SNTP Servers” on page 20.
<b>Server Version</b>	Default: 3; range: 1 - 7. Specifies the SNTP software version to use, and is assigned on a per-server basis. The version setting is backwards-compatible. For example, using version 3 means that the switch accepts versions 1 through 3.

## Menu: Viewing and Configuring SNTP

To View, Enable, and Modify SNTP Time Protocol:

1. From the Main Menu, select:
  2. **Switch Configuration...**
    1. **System Information**

## Time Protocols

### SNTP: Viewing, Selecting, and Configuring

```
=====-- CONSOLE - MANAGER MODE -----=====
                          Switch Configuration - System Information

System Name : HPswitch
System Contact :
System Location :

Inactivity Timeout (min) [0] : 0      MAC Age Time(sec) [300] : 300
Inbound Telnet Enabled [Yes] : Yes    Web Agent Enabled [Yes] : Yes

Time Sync Method [TIMEP]: TIMEP ← Time Protocol Selection Parameter
TimeP Mode [Disabled] : Disabled      - TIMEP
                                       - SNTP
                                       - None

Time Zone [0] : 0
Daylight Time Rule [None] : None

Actions->  Cancel      Edit      Save      Help

Cancel changes and return to previous screen.
Use arrow keys to change action selection and <Enter> to execute action.
```

**Figure 8-1. The System Information Screen (Default Values)**

2. Press **[E]** (for **E**dit). The cursor moves to the **System Name** field.
3. Use **[↓]** to move the cursor to the **Time Sync Method** field.
4. Use the Space bar to select **SNTP**, then press **[↓]** once to display and move to the **SNTP Mode** field.
5. Do one of the following:
  - Use the Space bar to select the **Broadcast** mode, then press **[↓]** to move the cursor to the **Poll Interval** field, and go to step 6. (For Broadcast mode details, see "SNTP Operating Modes" on page 8-2.)

```
Time Sync Method [None] : SNTP
SNTP Mode [Disabled] : Broadcast
Poll Interval (sec) [720] : 720
Time Zone [0] : 0
Daylight Time Rule [None] : None
```

- Use the Space bar to select the **Unicast** mode, then do the following:
  - i. Press **[→]** to move the cursor to the **Server Address** field.

- ii. Enter the IP address of the SNTP server you want the switch to use for time synchronization.

**Note:** This step replaces any previously configured server IP address. If you will be using backup SNTP servers (requires use of the CLI), then see “SNTP Unicast Time Polling with Multiple SNTP Servers” on page 8-20.

- iii. Press **↓** to move the cursor to the **Server Version** field. Enter the value that matches the SNTP server version running on the device you specified in the preceding step (step ii). If you are unsure which version to use, HP recommends leaving this value at the default setting of **3** and testing SNTP operation to determine whether any change is necessary.

**Note:** Using the menu to enter the IP address for an SNTP server when the switch already has one or more SNTP servers configured causes the switch to delete the primary SNTP server from the server list and to select a new primary SNTP server from the IP address(es) in the updated list. For more on this topic, see “SNTP Unicast Time Polling with Multiple SNTP Servers” on page 8-20.

- iv. Press **→** to move the cursor to the **Poll Interval** field, then go to step 6.

```
Time Sync Method [None] : SNTP
SNTP Mode [Disabled] : Unicast      Server Address : 10.28.227.15
Poll Interval (sec) [720] : 720     Server Version [3] : 3
Time Zone [0] : 0
Daylight Time Rule [None] : None
```

- 6. In the **Poll Interval** field, enter the time in seconds that you want for a Poll Interval. (For Poll Interval operation, see table 8-1, “SNTP Parameters”, on page 8-5.)
- 7. Press **Enter** to return to the Actions line, then **S** (for **Save**) to enter the new time protocol configuration in both the startup-config and running-config files.

## CLI: Viewing and Configuring SNTP

### CLI Commands Described in this Section

---

show sntp	page 8-8
[no] timesync	pages 8-9 and ff., 8-12
sntp broadcast	page 8-9
sntp unicast	page 8-10
sntp server	pages 8-10 and ff.
Protocol Version	page 8-12
poll-interval	page 8-12
no sntp	page 8-13

---

This section describes how to use the CLI to view, enable, and configure SNTP parameters.

### Viewing the Current SNTP Configuration

This command lists both the time synchronization method (**TimeP**, **SNTP**, or **None**) and the SNTP configuration, even if SNTP is not the selected time protocol.

**Syntax:** show sntp

For example, if you configured the switch with SNTP as the time synchronization method, then enabled SNTP in broadcast mode with the default poll interval, **show sntp** lists the following:

```
HPswitch# show sntp
SNTP Configuration
  Time Sync Mode: Sntp
  SNTP Mode : Broadcast
  Poll Interval (sec) [720] : 720
```

**Figure 8-2. Example of SNTP Configuration When SNTP Is the Selected Time Synchronization Method**

In the factory-default configuration (where TimeP is the selected time synchronization method), **show sntp** still lists the SNTP configuration even though it is not currently in use. For example:

```

HPswitch# show sntp
SNTP Configuration
Time Sync Mode: Timep
SNTP Mode : Broadcast
Poll Interval (sec) [720] : 720
  
```

Even though, in this example, TimeP is the current time synchronous method, the switch maintains the SNTP configuration.

**Figure 8-3. Example of SNTP Configuration When SNTP Is Not the Selected Time Synchronization Method**

### Configuring (Enabling or Disabling) the SNTP Mode

Enabling the SNTP mode means to configure it for either broadcast or unicast mode. Remember that to run SNTP as the switch's time synchronization protocol, you must also select SNTP as the time synchronization method by using the CLI **timesync** command (or the Menu interface **Time Sync Method** parameter).

- |                                   |   |
|-----------------------------------|---|
| <b>Syntax:</b> timesync sntp      | Selects SNTP as the time protocol.  |
| sntp < broadcast   unicast >      | Enables the SNTP mode (below and page 8-10).  |
| sntp server < ip-addr >           | Required only for unicast mode (page 8-10).   |
| sntp poll-interval < 30 . . 720 > | Enabling the SNTP mode also enables the SNTP poll interval (default: 720 seconds; page 8-12). |

**Enabling SNTP in Broadcast Mode.** Because the switch provides an SNTP polling interval (default: 720 seconds), you need only these two commands for minimal SNTP broadcast configuration:

- |                              |  |
|------------------------------|--|
| <b>Syntax:</b> timesync sntp | Selects SNTP as the time synchronization method. |
| sntp broadcast               | Configures <b>Broadcast</b> as the SNTP mode.    |

For example, suppose:

- Time synchronization is in the factory-default configuration (TimeP is the currently selected time synchronization method).
- You want to:
  1. View the current time synchronization.
  2. Select SNTP as the time synchronization mode.

## Time Protocols

### SNTP: Viewing, Selecting, and Configuring

3. Enable SNTP for Broadcast mode.
4. View the SNTP configuration again to verify the configuration.

The commands and output would appear as follows:

```
HPswitch(config)# show sntp 1
SNTP Configuration
  Time Sync Mode: Timep
  SNTP Mode : disabled
  Poll Interval (sec) [720] : 720
HPswitch(config)# timesync sntp 2
HPswitch(config)# sntp broadcast 3
HPswitch(config)# show sntp 4
```

**1** `show sntp` displays the SNTP configuration and also shows that TimeP is the currently active time synchronization mode.

**4** `show sntp` again displays the SNTP configuration and shows that SNTP is now the currently active time synchronization mode and is configured for broadcast operation.

**Figure 8-4. Example of Enabling SNTP Operation in Broadcast Mode**

**Enabling SNTP in Unicast Mode.** Like broadcast mode, configuring SNTP for unicast mode enables SNTP. However, for Unicast operation, you must also specify the IP address of at least one SNTP server. The switch allows up to three unicast servers. You can use the Menu interface or the CLI to configure one server or to replace an existing Unicast server with another. To add a second or third server, you must use the CLI. For more on SNTP operation with multiple servers, see “SNTP Unicast Time Polling with Multiple SNTP Servers” on page 20.

<b>Syntax:</b> <code>timesync sntp</code>	Selects SNTP as the time synchronization method.
<code>sntp unicast</code>	Configures the SNTP mode for Unicast operation.
<code>sntp server &lt;ip-addr&gt; [version]</code>	Specifies the SNTP server. The default server version is <b>3</b> .
<code>no sntp server &lt;ip-addr&gt;</code>	Deletes the specified SNTP server.

---

**Note**

---

Deleting an SNTP server when only one is configured disables SNTP unicast operation.

For example, to select SNTP and configure it with unicast mode and an SNTP server at 10.28.227.141 with the default server version (3) and default poll interval (720 seconds):

```
HPswitch(config)# timesync sntpSelects SNTP.  
HPswitch(config)# sntp unicastActivates SNTP in Unicast mode.  
HPswitch(config)# sntp server 10.28.227.141Specifies the  
SNTP server and accepts the  
current SNTP server version  
(default: 3).
```

```
HPswitch(config)# show sntp  
SNTP Configuration  
Time Sync Mode: Sntp  
SNTP Mode : Unicast  
Poll Interval (sec) [720] : 720  
IP Address          Protocol Version  
-----  
10.28.227.141      3
```

In this example, the **Poll Interval** and the **Protocol Version** appear at their default settings.

**Note:** Protocol Version appears only when there is an IP address configured for an SNTP server.

**Figure 8-5. Example of Configuring SNTP for Unicast Operation**

If the SNTP server you specify uses SNTP version 4 or later, use the `sntp server` command to specify the correct version number. For example, suppose you learned that SNTP version 4 was in use on the server you specified above (IP address 10.28.227.141). You would use the following commands to delete the server IP address and then re-enter it with the correct version number for that server:

## Time Protocols

### SNTP: Viewing, Selecting, and Configuring

```
HPswitch(config)# no sntp server 10.28.227.141
HPswitch(config)# sntp server 10.28.227.141 4
HPswitch(config)# show sntp
SNTP Configuration
  Time Sync Mode: Sntp
  SNTP Mode : Broadcast
  Poll Interval (sec) [720] : 600
  IP Address      Protocol Version
  -----
  10.28.227.141  4
```

Deletes unicast SNTP server entry.

Re-enters the unicast server with a non-default protocol version.

show sntp displays the result.

**Figure 8-6. Example of Specifying the SNTP Protocol Version Number**

**Changing the SNTP Poll Interval.** This command lets you specify how long the switch waits between time polling intervals. The default is 720 seconds and the range is 30 to 720 seconds. (This parameter is separate from the poll interval parameter used for Timep operation.)

**Syntax:** sntp poll-interval <30 . . 720>

For example, to change the poll interval to 300 seconds:

```
HPswitch(config)# sntp poll-interval 300
```

**Disabling Time Synchronization Without Changing the SNTP Configuration.** The recommended method for disabling time synchronization is to use the **timesync** command. This halts time synchronization without changing your SNTP configuration.

**Syntax:** no timesync

For example, suppose SNTP is running as the switch's time synchronization protocol, with **Broadcast** as the SNTP mode and the factory-default polling interval. You would halt time synchronization with this command:

```
HPswitch(config)# no timesync
```

If you then viewed the SNTP configuration, you would see the following:

```
HPswitch(config)# show sntp
SNTP Configuration
  Time Sync Mode: Disabled
  SNTP Mode : Broadcast
  Poll Interval (sec) [720] : 720
```

**Figure 8-7. Example of SNTP with Time Synchronization Disabled**



**Disabling the SNTP Mode.** If you want to prevent SNTP from being used even if selected by **timesync** (or the Menu interface’s **Time Sync Method** parameter), configure the SNTP mode as disabled.

**Syntax:** `no sntp` Disables SNTP by changing the SNTP mode configuration to **Disabled**.

For example, if the switch is running SNTP in Unicast mode with an SNTP server at 10.28.227.141 and a server version of 3 (the default), **no sntp** changes the SNTP configuration as shown below, and disables time synchronization on the switch.

```

HPswitch(config)# no sntp
HPswitch(config)# show sntp
SNTP Configuration
  Time Sync Mode: Sntp
  SNTP Mode : disabled
  Poll Interval (sec) [720] : 720
  IP Address          Protocol Version
  -----
  10.28.227.141      3
  
```

Even though the **Time Sync Mode** is set to **Sntp**, time synchronization is disabled because **no sntp** has disabled the **SNTP Mode** parameter.

**Figure 8-8. Example of Disabling Time Synchronization by Disabling the SNTP Mode**

## TimeP: Viewing, Selecting, and Configuring

TimeP Feature	Default	Menu	CLI	Web
view the Timep time synchronization configuration	n/a	page 8-14	page 8-16	—
select Timep as the time synchronization method	TIMEP	page 8-13	pages 8-17 ff.	—
disable time synchronization	timep	page 8-15	page 8-19	—
enable the Timep mode	Disabled			—
DHCP	—	page 8-15	page 8-17	—
manual	—	page 8-15	page 8-18	—
none/disabled	—	page 8-15	page 8-20	—
change the SNTP poll interval	720 minutes	page 8-16	page 8-19	—

**Table 8-2. Timep Parameters**

<b>SNTP Parameter</b>	<b>Operation</b>
<b>Time Sync Method</b>	Used to select either TIMEP (the default), SNTP, or None as the time synchronization method.
<b>Timep Mode</b>	
<b>Disabled</b>	The Default. Timep does not operate, even if specified by the Menu interface <b>Time Sync Method</b> parameter or the CLI <b>timesync</b> command.
<b>DHCP</b>	When Timep is selected as the time synchronization method, the switch attempts to acquire a Timep server IP address via DHCP. If the switch receives a server address, it polls the server for updates according to the Timep poll interval. If the switch does not receive a Timep server IP address, it cannot perform time synchronization updates.
<b>Manual</b>	When Timep is selected as the time synchronization method, the switch attempts to poll the specified server for updates according to the Timep poll interval. If the switch fails to receive updates from the server, time synchronization updates do not occur.
<b>Server Address</b>	Used only when the <b>TimeP Mode</b> is set to <b>Manual</b> . Specifies the IP address of the TimeP server that the switch accesses for time synchronization updates. You can configure one server.
<b>Poll Interval (minutes)</b>	Default: 720 minutes. Specifies the interval the switch waits between attempts to poll the TimeP server for updates.

## Menu: Viewing and Configuring TimeP

To View, Enable, and Modify the TimeP Protocol:

1. From the Main Menu, select:
  2. **Switch Configuration...**
    1. **System Information**

```
=====-- CONSOLE - MANAGER MODE -----  
Switch Configuration - System Information  
  
System Name : HPswitch  
System Contact :  
System Location :  
  
Inactivity Timeout (min) [0] : 0      MAC Age Time(sec) [300] : 300  
Inbound Telnet Enabled [Yes] : Yes    Web Agent Enabled [Yes] : Yes  
  
Time Sync Method [TIMEP]: TIMEP ← Time Protocol Selection Parameter  
TimeP Mode [Disabled] : Disabled      - TIMEP (the default)  
                                       - SNTP  
                                       - None  
  
Time Zone [0] : 0  
Daylight Time Rule [None] : None  
  
Actions->  Cancel      Edit      Save      Help  
  
Cancel changes and return to previous screen.  
Use arrow keys to change action selection and <Enter> to execute action.
```

**Figure 8-9. The System Information Screen (Default Values)**

2. Press **[E]** (for **Edit**). The cursor moves to the **System Name** field.
3. Use **[↓]** to move the cursor to the **Time Sync Method** field.
4. If **TIMEP** is not already selected, use the Space bar to select **TIMEP**, then press **[↓]** once to display and move to the **TimeP Mode** field.
5. Do one of the following:
  - Use the Space bar to select the **DHCP** mode, then press **[↓]** to move the cursor to the **Poll Interval** field, and go to step 6.

```
Time Sync Method [None] : TIMEP  
TimeP Mode [Disabled] : DHCP  
Poll Interval (min) [720] : 720  
Time Zone [0] : 0  
Daylight Time Rule [None] : None
```

- Use the Space bar to select the **Manual** mode.
  - i. Press **[→]** to move the cursor to the **Server Address** field.
  - ii. Enter the IP address of the TimeP server you want the switch to use for time synchronization.

## Time Protocols

### TimeP: Viewing, Selecting, and Configuring

**Note:** This step replaces any previously configured TimeP server IP address.

- iii. Press **[→]** to move the cursor to the **Poll Interval** field, then go to step 6.

```
Time Sync Method [None] : TIMEP
TimeP Mode [Disabled] : Manual      Server Address : 10.28.227.141
Poll Interval (min) [720] : 720
Time Zone [0] : 0
Daylight Time Rule [None] : None
```

6. In the **Poll Interval** field, enter the time in minutes that you want for a TimeP Poll Interval.

Press **[Enter]** to return to the Actions line, then **[S]** (for **Save**) to enter the new time protocol configuration in both the startup-config and running-config files.

## CLI: Viewing and Configuring TimeP

### CLI Commands Described in this Section

---

show timep	page 8-16
[no] timesync	page 8-17 ff., 8-19
ip timep	
dhcp	page 8-17
manual	page 8-18
server <ip-addr>	page 8-18
interval	page 8-19
no ip timep	page 8-20

---

This section describes how to use the CLI to view, enable, and configure TimeP parameters.

### Viewing the Current TimeP Configuration

This command lists both the time synchronization method (TimeP, SNTP, or None) and the TimeP configuration, even if SNTP is not the selected time protocol.

**Syntax:** show timep

For example, if you configure the switch with TimeP as the time synchronization method, then enable TimeP in DHCP mode with the default poll interval, **show timep** lists the following:

```
HPswitch(config)# show timep
Timep Configuration
Time Sync Mode: Timep
TimeP Mode : DHCP      Poll Interval (min) : 720
```

**Figure 8-10. Example of TimeP Configuration When TimeP Is the Selected Time Synchronization Method**

If SNTP is the selected time synchronization method, **show timep** still lists the TimeP configuration even though it is not currently in use:

```
HPswitch(config)# show timep
Timep Configuration
Time Sync Mode: Sntp
TimeP Mode : DHCP      Poll Interval (min) : 720
```

Even though, in this example, SNTP is the current time synchronization method, the switch maintains the TimeP configuration.

**Figure 8-11. Example of SNTP Configuration When SNTP Is Not the Selected Time Synchronization Method**

### Configuring (Enabling or Disabling) the TimeP Mode

Enabling the TimeP mode means to configure it for either broadcast or unicast mode. Remember that to run TimeP as the switch's time synchronization protocol, you must also select TimeP as the time synchronization method by using the CLI **timesync** command (or the Menu interface **Time Sync Method** parameter).

<b>Syntax:</b> <code>timesync timep</code>	Selects TimeP as the time protocol.
<code>ip timep &lt; dhcp   manual &gt;</code>	Enables the selected TimeP mode.
<code>no ip timep</code>	Disables the TimeP mode.
<code>no timesync</code>	Disables the time protocol.

**Enabling TimeP in DHCP Mode.** Because the switch provides a TimeP polling interval (default: 720 minutes), you need only these two commands for a minimal TimeP DHCP configuration:

<b>Syntax:</b> <code>timesync timep</code>	Selects TimeP as the time synchronization method.
<code>ip timep dhcp</code>	Configures DHCP as the TimeP mode.

## Time Protocols

### TimeP: Viewing, Selecting, and Configuring

For example, suppose:

- Time synchronization is configured for SNTP.
- You want to:
  1. View the current time synchronization.
  2. Select TimeP as the time synchronization mode.
  3. Enable TimeP for DHCP mode.
  4. View the TimeP configuration.

The commands and output would appear as follows:

```
HPswitch(config)# show timep ❶ show timep displays the TimeP configuration and also shows
Timep Configuration that SNTP is the currently active time synchronization mode.
Time Sync Mode: Sntp
TimeP Mode : Disabled

HPswitch(config)# timesync timep ❷

HPswitch(config)# ip timep dhcp ❸

HPswitch(config)# show timep ❹ show timep again displays the TimeP configuration and shows that TimeP
Timep Configuration show timep again displays the TimeP configuration and shows that TimeP is
Time Sync Mode: Timep now the currently active time synchronization mode.
TimeP Mode : DHCP Poll Interval (min) : 720
```

**Figure 8-12. Example of Enabling TimeP Operation in DHCP Mode**

**Enabling Timep in Manual Mode.** Like DHCP mode, configuring TimeP for **Manual** mode enables TimeP. However, for manual operation, you must also specify the IP address of the TimeP server. (The switch allows only one TimeP server.) To enable the TimeP protocol:

<b>Syntax:</b> timesync timep	Selects Timep.
ip timep manual <ip-addr>	Activates TimeP in Manual mode with a specified TimeP server.
no ip timep	Disables TimeP.

---

### Note

To change from one TimeP server to another, you must (1) use the **no ip timep** command to disable TimeP mode, and then reconfigure TimeP in Manual mode with the new server IP address.

---

For example, to select TimeP and configure it for manual operation using a TimeP server address of 10.28.227.141 and the default poll interval (720 minutes, assuming the TimeP poll interval is already set to the default):

```
HPswitch(config)# timesync timep Selects TimeP.
HPswitch(config)# ip timep manual Activates TimeP in Manual
10.28.227.141 mode.
```

```
HPswitch(config)# timesync timep
HPswitch(config)# ip timep manual 10.28.227.141

HPswitch(config)# Show timep
Timep Configuration
Time Sync Mode: Timep
TimeP Mode : Manual          Server Address : 10.28.227.141
Poll Interval (min) : 720
```

**Figure 8-13. Example of Configuring Timep for Manual Operation**

**Changing the TimeP Poll Interval.** This command lets you specify how long the switch waits between time polling intervals. The default is 720 minutes and the range is 1 to 9999 minutes. (This parameter is separate from the poll interval parameter used for SNTP operation.)

**Syntax:** ip timep dhcp interval <1 .. 9999>  
ip timep manual interval <1 .. 9999>

For example, to change the poll interval to 60 minutes:

```
HPswitch(config)# ip timep interval 60
```

**Disabling Time Synchronization Without Changing the TimeP Configuration.** The recommended method for disabling time synchronization is to use the **timesync** command. This halts time synchronization without changing your TimeP configuration.

**Syntax:** no timesync

For example, suppose TimeP is running as the switch's time synchronization protocol, with **DHCP** as the TimeP mode, and the factory-default polling interval. You would halt time synchronization with this command:

```
HPswitch(config)# no timesync
```

If you then viewed the TimeP configuration, you would see the following:

```
HPswitch(config)# show timep
Timep Configuration
Time Sync Mode: Disabled
TimeP Mode : DHCP    Poll Interval (min) : 720
```

**Figure 8-14. Example of TimeP with Time Synchronization Disabled**

**Disabling the TimeP Mode.** Disabling the TimeP mode means to configure it as disabled. (Disabling TimeP prevents the switch from using it as the time synchronization protocol, even if it is the selected **Time Sync Method** option.)

**Syntax:** no ip timep Disables TimeP by changing the TimeP mode configuration to **Disabled**.

For example, if the switch is running TimeP in DHCP mode, **no ip timep** changes the TimeP configuration as shown below, and disables time synchronization on the switch.

```
HPswitch(config)# no ip timep

HPswitch(config)# show timep
Timep Configuration
Time Sync Mode: Timep
TimeP Mode : Disabled
```

Even though the Time Sync Mode is set to Timep, time synchronization is disabled because no ip timep has disabled the TimeP Mode parameter.

**Figure 8-15. Example of Disabling Time Synchronization by Disabling the TimeP Mode Parameter**

---

## SNTP Unicast Time Polling with Multiple SNTP Servers

When running SNTP unicast time polling as the time synchronization method, the switch requests a time update from the server you configured with either the Server Address parameter in the menu interface, or the primary server in a list of up to three SNTP servers configured using the CLI. If the switch does not receive a response from the primary server after three consecutive polling intervals, the switch tries the next server (if any) in the list. If the switch tries



all servers in the list without success, it sends an error message to the Event Log and reschedules to try the address list again after the configured **Poll Interval** time has expired.

### Address Prioritization

If you use the CLI to configure multiple SNTP servers, the switch prioritizes them according to the decimal values of their IP addresses. That is, the switch compares the decimal value of the octets in the addresses and orders them accordingly, with the lowest decimal value assigned as the primary address, the second-lowest decimal value assigned as the next address, and the third-lowest decimal value as the last address. If the first octet is the same between two of the addresses, the second octet is compared, and so on. For example:

SNTP Server IP Address	Server Ranking According to Decimal Value of IP Address
10.28.227.141	Primary
10.28.227.153	Secondary
10.29.227.100	Tertiary

### Adding and Deleting SNTP Server Addresses

**Adding Addresses.** As mentioned earlier, you can configure one SNTP server address using either the Menu interface or the CLI. To configure a second and third address, you must use the CLI. For example, suppose you have already configured the primary address in the above table (10.28.227.141). To configure the remaining two addresses, you would do the following:

## Time Protocols

### SNTP Unicast Time Polling with Multiple SNTP Servers

```
HPswitch(config)# sntp server 10.29.227.100
HPswitch(config)# sntp server 10.28.227.153
HPswitch(config)# show sntp
SNTP Configuration
Time Sync Mode: Sntp
SNTP Mode : disabled
Poll Interval (sec) [720] : 720
IP Address          Protocol Version
-----
10.28.227.141      3
10.28.227.153      3
10.29.227.100      3
```

Prioritized list of SNTP Server IP Addresses

**Figure 8-16. Example of SNTP Server Address Prioritization**

---

#### Note

If there are already three SNTP server addresses configured on the switch, and you want to use the CLI to replace one of the existing addresses with a new one, you must delete the unwanted address before you configure the new one.

---

**Deleting Addresses.** To delete an address, you must use the CLI. If there are multiple addresses and you delete one of them, the switch re-orders the address priority. (See “Address Prioritization” on page 21.)

**Syntax:** no sntp server <ip-addr>

For example, to delete the primary address in the above example (and automatically convert the secondary address to primary):

```
HPswitch(config)# no sntp server 10.28.227.141
```

### Menu Interface Operation with Multiple SNTP Server Addresses Configured

When you use the Menu interface to configure an SNTP server IP address, the new address writes over the current primary address, if one is configured. If there are multiple addresses configured, the switch re-orders the addresses

according to the criteria described under “Address Prioritization” on page 21. For example, suppose the switch already has the following three SNTP server IP addresses configured.

- 10.28.227.141 (primary)
- 10.28.227.153 (secondary)
- 10.29.227.100 (tertiary)

If you use the Menu interface to add 10.28.227.160, the new prioritized list will be:

---

New Address List	Address Status
10.28.227.153	New Primary (The former primary, 10.28.227.141 was deleted when you used the menu to add 10.28.227.160.)
10.28.227.160	New Secondary
10.29.227.100	Same Tertiary (This address still has the highest decimal value.)

---

## SNTP Messages in the Event Log

If an SNTP time change of more than three seconds occurs, the switch’s event log records the change. SNTP time changes of less than three seconds do not appear in the Event Log.

**Time Protocols**  
SNTP Messages in the Event Log

# Optimizing Traffic Flow with Port Controls, Port Trunking, and Port-Based Priority

---

## Contents

<b>Overview</b> .....	9-2
<b>Viewing Port Status and Configuring Port Parameters</b> .....	9-2
Menu: Viewing Port Status and Configuring Port Parameters .....	9-5
CLI: Viewing Port Status and Configuring Port Parameters .....	9-6
Web: Viewing Port Status and Configuring Port Parameters .....	9-9
<b>Port Trunking</b> .....	9-10
Series 4100GL switches Port Trunk Features and Operation .....	9-11
Trunk Configuration Methods .....	9-12
Menu: Viewing and Configuring a Static Trunk Group .....	9-16
CLI: Viewing and Configuring a Static or Dynamic Port Trunk Group .....	9-18
Web: Viewing Existing Port Trunk Groups .....	9-24
Trunk Group Operation Using LACP .....	9-25
Trunk Group Operation Using the “Trunk” Option .....	9-30
Trunk Operation Using the “FEC” Option .....	9-30
How the Switch Lists Trunk Data .....	9-31
Outbound Traffic Distribution Across Trunked Links .....	9-31
<b>Configuring Port-Based Priority for Incoming Packets</b> .....	9-33
The Role of 802.1Q VLAN Tagging .....	9-33
Outbound Port Queues and Packet Priority Settings .....	9-34
Operating Rules for Port-Based Priority on Series 4100GL Switches .....	9-35
Configuring and Viewing Port-Based Priority .....	9-36
Messages Related to Prioritization .....	9-37
Troubleshooting Prioritization .....	9-37

## Overview

This chapter includes:

- **Configuring ports to non-default settings (page 9-2)**  
These settings include enable/disable, mode (speed and duplex), flow control, port-trunk group, and port-trunk type. You can also set a broadcast limit that applies to all ports on the switch.
  - **Port aggregation: Creating and modifying a port trunk group (page 9-10)**  
You can configure static and dynamic trunks. Includes non-protocol trunks, LACP (802.3ad) trunks, and FEC trunks.
  - **Configuring port-based priority for incoming packets (page 9-33)**  
This feature enables you to prioritize inbound traffic that either carries an 802.1Q VLAN tag with a priority of 0 (zero) or is not a tagged VLAN packet.
- 

## Viewing Port Status and Configuring Port Parameters

### Port Status and Configuration Features

Feature	Default	Menu	CLI	Web
viewing port status	n/a	page 9-5	page 9-6	page 9-9
configuring ports	See Table 9-9-1 on pages 9-3 and 9-4..	page 9-5	page 9-8	page 9-9

---

---

### Note On Connecting Transceivers to Fixed-Configuration Devices

If the switch either fails to show a link between an installed transceiver and another device, or demonstrates errors or other unexpected behavior on the link, check the port configuration on both devices for a speed and/or duplex (mode) mismatch. To check the mode setting for a port on a Series 4100GL switches, use either the Port Status screen in the menu interface (page 9-5) or **show interfaces brief** in the CLI (page 9-6).

---

**Table 9-1. Status and Parameters for Each Port Type**

Status or Parameter	Description
Enabled	<p><b>Yes</b> (default): The port is ready for a network connection.</p> <p><b>No</b>: The port will not operate, even if properly connected in a network. Use this setting, for example, if the port needs to be shut down for diagnostic purposes or while you are making topology changes.</p>
Status (read-only)	<p><b>Up</b>: The port senses a linkbeat.</p> <p><b>Down</b>: The port is not enabled, has no cables connected, or is experiencing a network error. For troubleshooting information, see the installation manual you received with the switch. See also chapter 11, “Troubleshooting” (in this manual).</p>
Mode	<p>The port’s speed and duplex (data transfer operation) setting.</p> <p>10/100Base-T ports:</p> <ul style="list-style-type: none"> <li>• Auto (default): Senses speed and negotiates with the port at the other end of the link for data transfer operation (half-duplex or full-duplex). <ul style="list-style-type: none"> <li><b>Note:</b> Ensure that the device attached to the port is configured for the same setting that you select here. Also, if “Auto” is used, the device to which the port is connected must operate in compliance with the IEEE 802.3u “Auto Negotiation” standard for 100Base-T networks. If the other device does not comply with the 802.3u standard, or is not set to Auto, then the port configuration on the switch must be manually set to match the port configuration on the other device.</li> </ul> </li> <li>To see what the switch negotiates for the Auto setting, use the CLI <b>show interfaces</b> command or the “<b>3. Port Status</b>” option under “<b>1. Status and Counters</b>” in the menu interface.</li> <li>• Auto-10: Allows the port to negotiate between half-duplex (HDx) and full-duplex (FDx) while keeping speed at 10 Mbps. Also negotiates flow control (enabled or disabled). HP recommends Auto-10 for links between 10/100 autosensing ports connected with Cat 3 cabling. (Cat 5 cabling is required for 100 Mbps links.).</li> <li>• 10HDx: 10 Mbps, Half-Duplex</li> <li>• 10FDx: 10 Mbps, Full-Duplex</li> <li>• 100HDx: 100 Mbps, Half-Duplex</li> <li>• 100FDx: 100 Mbps, Full-Duplex</li> </ul> <p>100FX ports:</p> <ul style="list-style-type: none"> <li>• 100HDx: 100 Mbps, Half-Duplex</li> <li>• 100FDx (default): 100 Mbps, Full-Duplex</li> </ul>

## Optimizing Traffic Flow with Port Controls, Port Trunking, and Port-Based Priority

### Viewing Port Status and Configuring Port Parameters

Status or Parameter	Description
	<p>100/1000Base-T ports:</p> <ul style="list-style-type: none"> <li>Auto (default): Senses speed and negotiates with the port at the other end of the link for port operation (MDI-X or MDI). To see what the switch negotiates for the Auto setting, use the CLI <b>show interfaces brief</b> command or the "3. Port Status" option under "1. Status and Counters" in the menu interface.</li> <li>Auto-100: Uses 100 Mbps and negotiates with the port at the other end of the link for other port operation features.</li> <li>Auto-1000: Uses 1000 Mbps and negotiates with the port at the other end of the link for other port operation features.</li> <li>100Hdx: Uses 100 Mbps, half-duplex.</li> <li>100Fdx: Uses 100 Mbps, Full-Duplex</li> </ul> <p><b>Notes:</b></p> <ul style="list-style-type: none"> <li>Changing the port speed on a transceiver port requires a reboot of the switch.</li> <li>Ensure that the device attached to the port is configured for the same setting that you select here. Also, if "Auto" is used, the device to which the port is connected must also be configured to "Auto" and operate in compliance with the IEEE 802.3ab "Auto Negotiation" standard for 1000Base-T networks.</li> </ul>
	<p>Gigabit fiber-optic ports (Gigabit-SX and Gigabit-LX):</p> <ul style="list-style-type: none"> <li>1000FDx: 1000 Mbps (1 Gbps), Full Duplex only</li> <li>Auto (default): The port operates at 1000FDx and auto-negotiates flow control with the device connected to the port.</li> </ul>
Flow Control	<ul style="list-style-type: none"> <li>Disabled (default): The port will not generate flow control packets, and drops any flow control packets it receives.</li> <li>Enabled: The port uses 802.3x Link Layer Flow Control, generates flow control packets, and processes received flow control packets.</li> </ul> <p>With the port mode set to Auto (the default) and Flow Control enabled, the switch negotiates Flow Control on the indicated port. If the port mode is not set to Auto, or if Flow Control is disabled on the port, then Flow Control is not used.</p>
Group (menu) or Trunk Group (CLI)	<p>Menu Interface: Specifies the static trunk group, if any, to which a port belongs.</p> <p>CLI: Appears in the <b>show lacp</b> command output to show the LACP trunk, if any, to which a port belongs. <b>Note:</b> An LACP trunk requires a full-duplex link. In most cases, HP recommends that you leave the port Mode setting at Auto (the default). See the LACP Note on page 9-11. <i>For more on port trunking, see "Port Trunking" on page 9-10.</i></p>
Type	<p>This parameter appears in the CLI <b>show trunk</b> listing and, for a port in a trunk group, specifies the type of trunk group. The default Type is passive LACP, which can be displayed by using the CLI <b>show lacp</b> command. <i>For more on port trunking, see "Port Trunking" on page 9-10.</i></p>
Broadcast Limit	<p>Specifies the theoretical maximum of network bandwidth percentage that can be used for broadcast and multicast traffic. Any broadcast or multicast traffic exceeding that limit will be dropped. Zero (0) means the feature is disabled. <b>Note:</b> The broadcast limit command sets the broadcast limit for all ports on the switch.</p>



## Menu: Viewing Port Status and Configuring Port Parameters

From the menu interface, you can configure and view all port parameter settings and view all port status indicators.

**Using the Menu To View Port Status.** The menu interface displays the status for ports and (if configured) a trunk group.

From the Main Menu, select:

### 1. Status and Counters . . .

### 4. Port Status

In this example, ports A7 and A8 have previously been configured as a trunk group.

```
----- CONSOLE - MANAGER MODE -----
                Status and Counters - Port Status
-----
```

Port	Type	Intrusion Alert	Enabled	Status	Mode	Flow Ctrl
A1	10/100TX	No	Yes	Up	10HDx	off
A2	10/100TX	No	Yes	Up	100FDx	off
A3	10/100TX	No	Yes	Up	100FDx	off
A4	10/100TX	No	Yes	Up	100FDx	off
A5	10/100TX	No	Yes	Up	100FDx	off
A6	10/100TX	No	Yes	Up	10HDx	off
A7-Trk2	10/100TX	No	Yes	Up	100FDx	off
A8-Trk2	10/100TX	No	Yes	Up	100FDx	off
A9	10/100TX	No	Yes	Down	10HDx	off
A10	10/100TX	No	Yes	Down	10HDx	off
A11	10/100TX	No	Yes	Up	10HDx	off

```
Actions->  Back  Intrusion log  Help
Return to previous screen.
Use up/down arrow keys to scroll to other entries, left/right arrow keys to
change action selection, and <Enter> to execute action.
```

Figure 9-1. Example of the Port Status Screen

### Using the Menu To Configure Ports.

#### Note

The menu interface uses the same screen for configuring both individual ports and port trunk groups. For information on port trunk groups, see “Port Trunking” on page 9-10.

1. From the Main Menu, Select:
  2. Switch Configuration...
  2. Port/Trunk Settings

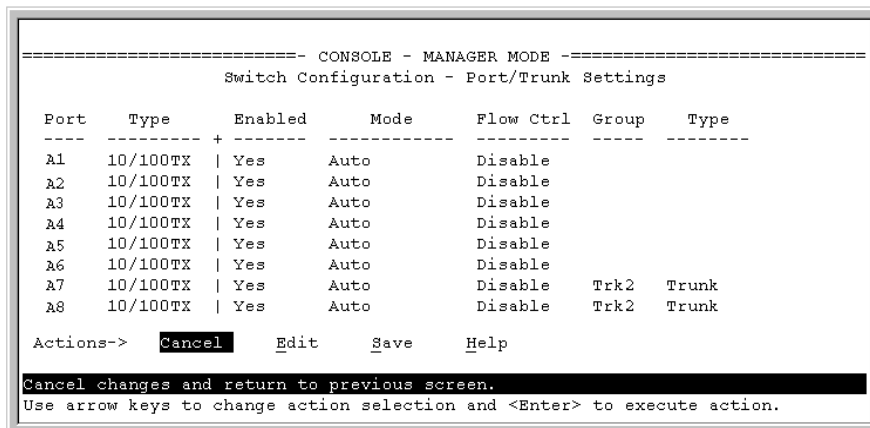

**Figure 9-2. Example of Port/Trunk Settings with a Trunk Group Configured**

2. Press **[E]** (for **E**dit). The cursor moves to the **Enabled** field for the first port.
3. Refer to the online help provided with this screen for further information on configuration options for these features.
4. When you have finished making changes to the above parameters, press **[Enter]**, then press **[S]** (for **S**ave).

## CLI: Viewing Port Status and Configuring Port Parameters

### Port Status and Configuration Commands

show interfaces brief	below
show interface config	page 9-7
interface	page 9-8

From the CLI, you can configure and view all port parameter settings and view all port status indicators.

**Using the CLI To View Port Status.** Use the following commands to display port status and configuration:

- **show interfaces brief:** Lists the full status and configuration for all ports on the switch.
- **show interface config:** Lists a subset of the data shown by the **show interfaces** command (above); that is, only the enabled/disabled, mode, and flow control status for all ports on the switch.

**Syntax:** show interfaces brief  
show interface config

The next two figures list examples of the output of the above two commands for the same port configuration.

```
HPswitch> show interfaces brief
Status and Counters - Port Status
```

Port	Type	Intrusion Alert	Enabled	Status	Mode	Flow Ctrl
A1	10/100TX	No	Yes	Up	10HDx	off
A2	10/100TX	No	Yes	Up	100FDx	off
A3	10/100TX	No	Yes	Up	100FDx	off
A4	10/100TX	No	Yes	Up	100FDx	off
A5	10/100TX	No	Yes	Up	100FDx	off
A6	10/100TX	No	Yes	Up	100FDx	off
A7-Trk2	10/100TX	No	Yes	Up	100FDx	off
A8-Trk2	10/100TX	No	Yes	Up	100FDx	off
.	.	.	.	.	.	.
.	.	.	.	.	.	.
.	.	.	.	.	.	.
A17	10/100TX	No	Yes	Down	10HDx	off

-- MORE --, next page: Space, next line: Enter, quit: Control-C

**Figure 9-3. Example of a Show Interface Command Listing**

```
HPswitch> show interface config
Port Settings
```

Port	Type	Enabled	Mode	Flow Ctrl
A1	10/100TX	Yes	Auto	Disable
A2	10/100TX	Yes	Auto	Disable
A3	10/100TX	Yes	Auto	Disable
A4	10/100TX	Yes	Auto	Disable
A5	10/100TX	Yes	Auto	Disable
A6	10/100TX	Yes	Auto	Disable
A7-Trk2	10/100TX	Yes	Auto	Disable
A8-Trk2	10/100TX	Yes	Auto	Disable
.	.	.	.	.
.	.	.	.	.
.	.	.	.	.
A18	10/100TX	Yes	Auto	Disable

-- MORE --, next page: Space, next line: Enter, quit: Control-C

**Figure 9-4. Example of a Show Interface Config Command Listing**

**Using the CLI To Configure Ports.** You can configure one or more of the following port parameters. For details on each option, see Table 9-9-1 on page 9-3.

**Syntax:** [no] interface <[ethernet] *port-list*>  
          disable | enable  
          speed-duplex  
              <auto-10 |10-full | 10-half | 100-full | 100-half |auto|1000-full |>  
          flow-control

Note that in the above syntax you can substitute an “**int**” for “**interface**” and an “**e**” for “**ethernet**”; that is **int e <port-list>**.

For example, to configure ports C1 through C3 and port C6 for 100Mbps full-duplex, you would enter these commands:

```
HPswitch(config)# int e c1-c3,c6 speed-duplex 100-full
```

Similarly, to configure a single port with the settings in the above command, you could either enter the same command with only the one port identified, or go to the *context level* for that port and then enter the command. For example, to enter the context level for port C6 and then configure that port for 100FDx :

```
HPswitch(config)# int e c6  
HPswitch(eth-C6)# speed-duplex 100-full
```

If port C8 was disabled, and you wanted to enable it and configure it for 100FDx with flow-control active, you could do so with either of the following command sets.

- These commands enable and configure port C8 from the config level:  
HPswitch(config)# int e c8 enable  
HPswitch(config)# int e c8 speed-duplex 100-full  
HPswitch(config)# int e c8 flow-control
- These commands select the context level for port C8 and then apply all of the configuration commands to port C8:  
HPswitch(config)# int e c8  
HPswitch(eth-C8)# enable  
HPswitch(eth-C8)# speed-duplex 100-full  
HPswitch(eth-C8)# flow-control

**Configuring a Broadcast Limit on the Switch.** Executing this command configures the broadcast limit for all ports on the switch.

**Syntax:** broadcast-limit < 0..99 >

For example, to configure a broadcast limit of 20% for all ports on the switch:

```
HPswitch(config)# broadcast-limit 20
```

To display the current broadcast limit setting, use one of the following commands:

```
HPswitch# show config
```

Displays the startup-config file. The broadcast limit setting appears here if configured and saved to the startup-config file.

```
HPswitch# show running-config
```

Displays the running-config file.

## Web: Viewing Port Status and Configuring Port Parameters

In the web browser interface:

1. Click on the **Configuration** tab.
2. Click on [Port Configuration](#).
3. Select the ports you want to modify and click on [Modify Selected Ports](#).
4. After you make the desired changes, click on [Apply Settings](#).

Note that the web browser interface displays an existing port trunk group. However, to configure a port trunk group, you must use the CLI or the menu interface. For more on this topic, see “Port Trunking” on page 9-10.

# Port Trunking

## Port Status and Configuration Features

Feature	Default	Menu	CLI	Web
viewing port trunks	n/a	page 9-16	page 9-18	page 9-24
configuring a static trunk group	none	page 9-16	page 9-22	—
configuring a dynamic LACP trunk group	LACP passive	—	page 9-23	—

Port trunking allows you to assign up to four physical links to one logical link (trunk) that functions as a single, higher-speed link providing dramatically increased bandwidth. This capability applies to connections between backbone devices as well as to connections in other network areas where traffic bottlenecks exist. A *trunk group* is a set of up to four ports configured as members of the same port trunk. Note that the ports in a trunk group do not have to be consecutive. For example:

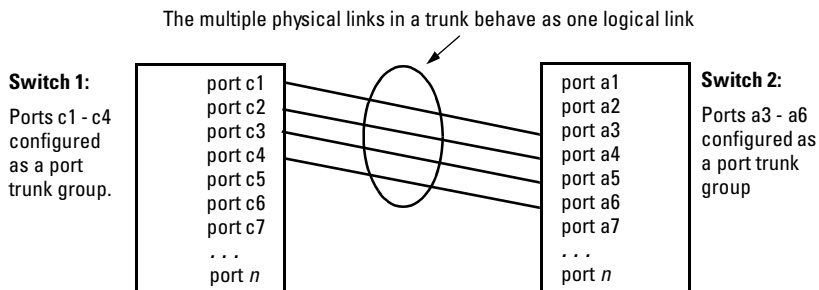

**Figure 9-5. Conceptual Example of Port Trunking**

**Port Connections and Configuration:** All port trunk links must be point-to-point connections between the Series 4100GL switches and another switch, router, server, or workstation configured for port trunking. No intervening, non-trunking devices are allowed. It is important to note that ports on both ends of a port trunk group must have the same mode (speed and duplex) and flow control settings.

---

**Note**

**Link Connections.** The switch does not support port trunking through an intermediate, non-trunking device such as a hub, or using more than one media type in a port trunk group. Similarly, all links in the same trunk group must have the same speed, duplex, and flow control.

**Port Security Restriction.** Port security does not operate on a trunk group. If you configure port security on one or more ports that are later added to a trunk group, the switch will reset the port security parameters for those ports to the factory-default configuration.

---

**Caution**

**To avoid broadcast storms or loops** in your network while configuring a trunk, first disable or disconnect all ports you want to add to or remove from the trunk. After you finish configuring the trunk, enable or re-connect the ports.

## Series 4100GL switches Port Trunk Features and Operation

The Series 4100GL switches offers these options for port trunking:

- LACP (IEEE 802.3ad—page 9-25)
- Trunk (non-protocol—page 9-30)
- FEC (Fast EtherChannel®—page 9-30)

The switch supports six trunk groups of up to four ports each. (Using the Link Aggregation Control Protocol—LACP—option, you can include standby trunked ports in addition to the maximum of four actively trunking ports.)

---

**LACP Note**

LACP operation requires full-duplex (FDx) links. For most installations, HP recommends that you leave the port Mode settings at **Auto** (the default). LACP also operates with **Auto-10**, **Auto-100**, and **Auto-1000** (if negotiation selects FDx); **10FDx**, **100FDx**, and **1000FDx** settings.

**Fault Tolerance:** If a link in a port trunk fails, the switch redistributes traffic originally destined for that link to the remaining links in the trunk. The trunk remains operable as long as there is at least one link in operation. If a link is restored, that link is automatically included in the traffic distribution again. The LACP option also offers a standby link capability, which enables you to keep links in reserve for service if one or more of the original active links fails. See “Trunk Group Operation Using LACP” on page 9-25.)

## Trunk Configuration Methods

**Dynamic LACP Trunk:** The switch automatically negotiates trunked links between LACP-configured ports on separate devices, and offers one dynamic trunk option: LACP. To configure the switch to initiate a dynamic LACP trunk with another device, use the **interface ethernet** command in the CLI to set the default LACP option to **Active** on the ports you want to use for the trunk. For example, the following command sets ports C1-C4 to LACP active:

```
HPswitch(config) int e c1-c4 lacp active
```

Note that the above example works if the ports are not already operating in a trunk. To change the LACP option on ports already operating as a trunk, you must first remove them from the trunk. For example, if ports C1 - C4 were LACP-active and operating in a trunk with another device, you would do the following to change them to LACP-passive:

```
HPswitch(config)# no int e c1-c4 lacp
```

*Removes the ports from the trunk.*

```
HPswitch(config)# int e c1-c4 lacp passive
```

*Configures LACP passive.*

**Static Trunk:** The switch uses the links you configure with the Port/Trunk Settings screen in the menu interface or the **trunk** command in the CLI to create a static port trunk. The switch offers three types of static trunks: LACP, Trunk, and FEC.

**Table 9-2. Trunk Types Used in Static and Dynamic Trunk Groups**

Trunking Method	LACP	Trunk	FEC
Dynamic	Yes	No	No
Static	Yes	Yes	Yes



**Table 9-3. Trunk Configuration Protocols**

Protocol	Trunking Options
LACP (802.3ad)	<p>Provides dynamic and static LACP trunking options.</p> <ul style="list-style-type: none"> <li>• <b>Dynamic LACP</b> — Use the switch-negotiated dynamic LACP trunk when: <ul style="list-style-type: none"> <li>– The port on the other end of the trunk link is configured for Active or Passive LACP.</li> <li>– You want to achieve fault-tolerance for high-availability applications where you want a four-link trunk with one or more standby links available in case an active link goes down. (Both ends of the link must be dynamic LACP.)</li> </ul> </li> <li>• <b>Static LACP</b> — Use the manually configured static LACP trunk when: <ul style="list-style-type: none"> <li>– The port on the other end of the trunk link is configured for a static LACP trunk</li> <li>– You want to configure non-default spanning tree (STP) or IGMP parameters on an LACP trunk group.</li> <li>– <i>You want an LACP trunk group to operate in a VLAN other than the default VLAN and GVRP is disabled. (Refer to “VLANs and Dynamic LACP” on page 9-29.)</i></li> <li>– You want to use a monitor port on the switch to monitor an LACP trunk.</li> </ul> </li> </ul> <p>See “Trunk Group Operation Using LACP” on page 9-25.</p>
Trunk (non-protocol)	<p>Provides manually configured, static-only trunking to:</p> <ul style="list-style-type: none"> <li>• Most HP switches and routing switches not running the 802.3ad LACP protocol.</li> <li>• Windows NT and HP-UX workstations and servers</li> </ul> <p>Use the Trunk option when:</p> <ul style="list-style-type: none"> <li>– The device to which you want to create a trunk link is using a non-802.3ad trunking protocol</li> <li>– You are unsure which type of trunk to use, or the device to which you want to create a trunk link is using an unknown trunking protocol.</li> <li>– You want to use a monitor port on the switch to monitor traffic on a trunk.</li> </ul> <p>See “Trunk Group Operation Using the “Trunk” Option” on page 9-30.</p>
FEC	<p>Provides static trunking to forwarding devices that also support FEC (Fast EtherChannel<sup>®</sup>), such as some Cisco<sup>®</sup> switches and routers, and some HP-UX and Windows NT servers.</p> <p>See “Trunk Operation Using the FEC Option” on page 9-30.</p>

**Table 9-4. General Operating Rules for Port Trunks**

**Media:** All ports on both ends of a trunk group must have the same media type and mode (speed and duplex). The switch blocks any trunked links that do not conform to this rule. (For the Series 4100GL switches, HP recommends leaving the port Mode setting at **Auto** or, in networks using Cat 3 cabling, **Auto-10**.)

**Port Configuration:** The default port configuration on the Series 4100GL switches is Auto, which enables a port to sense speed and negotiate duplex with an Auto-enabled port on another device. HP recommends that you use the Auto setting for all ports you plan to use for trunking. Otherwise, you must manually ensure that the mode setting for each port in a trunk is compatible with the other ports in the trunk.

```
HPswitch(config)# show interface config
Port Settings
Port Type      | Enabled Mode      | Flow Ctrl
-----+-----
C1  10/100TX    | Yes   Auto        | Disable
C2  10/100TX    | Yes   Auto        | Disable
```

Recommended Port Mode Setting for LACP

All of the following operate on a per-port basis, regardless of trunk membership:

- Enable/Disable
- Flow control (Flow Ctrl)

LACP is a full-duplex protocol. See “Trunk Group Operation Using LACP” on page 9-25.

**Trunk Configuration:** All ports in the same trunk group must be the same trunk type (LACP, Trunk, or FEC). All LACP ports in the same trunk group must be either all static LACP or all dynamic LACP.

A trunk appears as a single port labeled **Dyn1** (for an LACP dynamic trunk) or **Trk1** (for a static trunk of any type: LACP, Trunk, or FEC) on various menu and CLI screens. For a listing of which screens show which trunk types, see “How the Switch Lists Trunk Data” on page 9-31.

For STP or VLAN operation, configuration for all ports in a trunk is done at the trunk level. (You cannot separately configure individual ports within a trunk for STP or VLAN operation.)

**Traffic Distribution:** All of the switch trunk protocols use the SA/DA (Source Address/Destination Address) method of distributing traffic across the trunked links. See “Outbound Traffic Distribution Across Trunked Links” on page 9-31.

**Spanning Tree** : Spanning Tree operates as a global setting on the switch (one instance of Spanning Tree per switch). However, you can adjust Spanning Tree parameters on a per-port basis. A static trunk of any type appears in the Spanning Tree configuration display, and you can configure Spanning Tree parameters for a static trunk in the same way that you would configure Spanning Tree parameters on a non-trunked port. (Note that the switch lists the trunk by name—such as **Trk1**—and does not list the individual ports in the trunk.) For example, if ports C1 and C2 are configured as a static trunk named **Trk1**, they are listed in the Spanning Tree display as **Trk1** and do not appear as individual ports in the Spanning Tree displays.

In this example showing part of the **show spanning-tree** listing, ports C1 and C2 are members of TRK1 and do not appear as individual ports in the port configuration part of the listing.

Port	Type	Cost	Priority	State	Designated Bridge
C3	100/1000T	5	128	Forwarding	0020c1-b27ac0
C4	100/1000T	5	128	Forwarding	0060b0-889e00
C5	100/1000T	5	128	Disabled	
C6	100/1000T	5	128	Disabled	
Trk1		1	64	Forwarding	0001e7-a0ec00

When Spanning Tree forwards on a trunk, all ports in the trunk will be forwarding. Conversely, when Spanning Tree blocks a trunk, all ports in the trunk are blocked.

**Note:** A dynamic LACP trunk operates only with the default Spanning Tree settings and does not appear in the Spanning Tree configuration display or **show ip igmp** listing.

If you remove a port from a static trunk, the port retains the same Spanning Tree settings that were configured for the trunk.

**IP Multicast Protocol (IGMP):** A static trunk of any type appears in the IGMP configuration display, and you can configure IGMP for a static trunk in the same way that you would configure IGMP on a non-trunked port. (Note that the switch lists the trunk by name—such as **Trk1**—and does not list the individual ports in the trunk.) Also, creating a new trunk automatically places the trunk in IGMP Auto status if IGMP is enabled for the default VLAN. A dynamic LACP trunk operates only with the default IGMP settings and does not appear in the IGMP configuration display or **show ip igmp** listing.

**VLANs:** Creating a new trunk automatically places the trunk in the DEFAULT\_VLAN, regardless of whether the ports in the trunk were in another VLAN. Similarly, removing a port from a trunk group automatically places the port in the default VLAN. You can configure a static trunk in the same way that you configure a port for membership in any VLAN.

**Note:** For a dynamic trunk to operate in a VLAN other than the default VLAN (DEFAULT\_VLAN), GVRP must be enabled. See “Trunk Group Operation Using LACP” on page 9-25.

**Port Security:** Trunk groups (and their individual ports) cannot be configured for port security, and the switch excludes trunked ports from the **show port-security** listing. If you configure non-default port security settings for a port, then subsequently try to place the port in a trunk, you will see the following message and the command will not be executed:

```
< port-list > Command cannot operate over a logical port.
```

**Monitor Port:**

**Note:** A trunk cannot be a monitor port. A monitor port can monitor a static trunk but cannot monitor a dynamic LACP trunk.

## Menu: Viewing and Configuring a Static Trunk Group

---

### Important

Configure port trunking *before* you connect the trunked links to another switch, routing switch, or server. Otherwise, a broadcast storm could occur. (If you need to connect the ports before configuring them for trunking, you can temporarily disable the ports until the trunk is configured. See “Using the CLI To Configure Ports” on page 9-8.)

---

**To View and/or Configure Static Port Trunking:** This procedure uses the Port/Trunk Settings screen to configure a static port trunk group on the switch.

1. Follow the procedures in the Important note above.
2. From the Main Menu, Select:  
**2. Switch Configuration . . .**  
**2. Port/Trunk Settings**
3. Press **[E]** (for **Edit**) and then use the arrow keys to access the port trunk parameters.

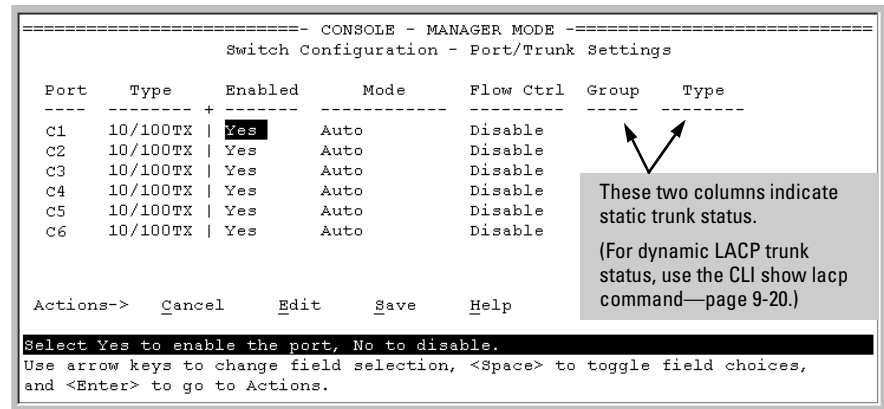

**Figure 9-6. Example of the Menu Screen for Configuring a Port Trunk Group**

4. In the Group column, move the cursor to the port you want to configure.
5. Use the Space bar to choose a trunk group (**Trk1 . . . Trk6**) trunk group assignment for the selected port.

- All ports in a trunk must have the same media type and mode (such as 10/100TX set to 100FDx, or 100FX set to 100FDx). The flow control settings must also be the same for all ports in a given trunk. To verify these settings, see “Viewing Port Status and Configuring Port Parameters” on page 9-2.
- You can configure the trunk group with one, two, three, or four ports per trunk. If multiple VLANs are configured, all ports within a trunk will be assigned to the same VLAN or set of VLANs. (With the 802.1Q VLAN capability built into the switch, more than one VLAN can be assigned to a trunk. See “Port-Based Virtual LANs (Static VLANs)” on page 11-3.)

(To return a port to a non-trunk status, keep pressing the Space bar until a blank appears in the highlighted Group value for that port.)

```

=====  CONSOLE - MANAGER MODE  =====
Switch Configuration - Port/Trunk Settings

Port   Type      Enabled  Mode      Flow Ctrl  Group  Type
-----+-----
C1     10/100TX  | Yes    Auto      Disable    -----
C2     10/100TX  | Yes    Auto      Disable    -----
C3     10/100TX  | Yes    Auto      Disable    -----
C4     10/100TX  | Yes    Auto      Disable    -----
C5     10/100TX  | Yes    Auto      Disable    Trk1  Trunk
C6     10/100TX  | Yes    Auto      Disable    Trk1  Trunk

Actions->  Cancell  Edit     Save     Help

Select whether the port is part of a trunk or Mesh.
Use arrow keys to change field selection, <Space> to toggle field choices,
and <Enter> to go to Actions.

```

**Figure 9-7. Example of the Configuration for a Two-Port Trunk Group**

6. Move the cursor to the Type column for the selected port and use the Space bar to select the trunk type:
  - LACP
  - Trunk (the default type if you do not specify a type)
  - FEC (Fast EtherChannel<sup>®</sup> trunk)

All ports in the same trunk group on the same switch must have the same Type (**LACP**, **Trunk**, or **FEC**).

7. When you are finished assigning ports to the trunk group, press **[Enter]**, then **[S]** (for **Save**) and return to the Main Menu. (It is not necessary to reboot the switch.)

During the Save process, traffic on the ports configured for trunking will be delayed for several seconds. If the Spanning Tree Protocol is enabled, the delay may be up to 30 seconds.

8. Connect the trunked ports on the switch to the corresponding ports on the opposite device. If you previously disabled any of the trunked ports on the switch, enable them now. (See “Viewing Port Status and Configuring Port Parameters” on page 9-2.)

Check the Event Log (“Using the Event Log To Identify Problem Sources” on page C-21) to verify that the trunked ports are operating properly.

## CLI: Viewing and Configuring a Static or Dynamic Port Trunk Group

### Trunk Status and Configuration Commands

---

show trunks	below
show lacp	page 9-20
trunk	page 9-22
interface lacp	page 9-23

---

### Using the CLI To View Port Trunks

You can list the trunk type and group for all ports on the switch or for selected ports. You can also list LACP-only status information for LACP-configured ports.

### Listing Static Trunk Type and Group for All Ports or Selected Ports.

**Syntax:** show trunks [*<port-list>*]

Omitting the **<port-list>** parameter results in a static trunk data listing for all LAN ports in the switch. For example, in a switch where ports A4 and A5 belong to Trunk 1 and ports A7 and A8 belong to Trunk 2, you have the options shown in figures 9-9-8 and 9-9-9 for displaying port data for ports belonging to static trunks.

Using a port list specifies, for switch ports in a static trunk group, only the ports you want to view. In this case, the command specifies ports A5 through A7. However, because port A6 is not in a static trunk group, it does not appear in the resulting listing:

```

Port A5 appears with an example of a name that you can optionally assign using the
Friendly Port Names feature. (See "Using Friendly (Optional) Port Names" on page 6-15.)

HPswitch> show trunks e a5-a7

Load Balancing

  Port | Name | Type | Group | Type
-----+-----+-----+-----+-----
  A5   | Print-Server-Trunk | 10/100TX | Trk1 | Trunk
  A7   | not assigned | 10/100TX | Trk2 | Trunk

```

Port A6 does not appear in this listing because it is not assigned to a static trunk.

**Figure 9-8. Example Listing Specific Ports Belonging to Static Trunks**

The **show trunks [ e ] < port-list >** command in the above example includes a port list, and thus shows trunk group information only for specific ports that have membership in a static trunk. In figure 9-9-9, the command does not include a port list, so the switch lists all ports having static trunk membership.

```

HPswitch> show trunks

Load Balancing

  Port | Name | Type | Group | Type
-----+-----+-----+-----+-----
  A4   | Print-Server-Trunk | 10/100TX | Trk1 | Trunk
  A5   | Print-Server-Trunk | 10/100TX | Trk1 | Trunk
  A7   | not assigned | 10/100TX | Trk2 | Trunk
  A8   | not assigned | 10/100TX | Trk2 | Trunk

```

**Figure 9-9. Example of a Show Trunk Listing Without Specifying Ports**

**Listing Static LACP and Dynamic LACP Trunk Data.** This command lists data for only the LACP-configured ports.

**Syntax:** show lacp

In the following example, ports A1 and A2 have been previously configured for a static LACP trunk. (For more on “Active”, see table 11-9-6 on page 9-27.)

```
HPswitch> show lacp
```

LACP					
PORT NUMB	LACP ENABLED	TRUNK GROUP	PORT STATUS	LACP PARTNER	LACP STATUS
A1	Active	Trk1	Up	Yes	Success
A2	Active	Trk1	Up	Yes	Success
A3	Active	A3	Down	No	Success
A4	Passive	A4	Down	No	Success
A5	Passive	A5	Down	No	Success
A6	Passive	A6	Down	No	Success

**Figure 9-10. Example of a Show LACP Listing**

**Dynamic LACP Standby Links.** Dynamic LACP trunking enables you to configure standby links for a trunk by including more than four ports in a dynamic LACP trunk configuration. When four ports (trunk links) are up, the remaining link(s) will be held in standby status. If a trunked link that is “Up” fails, it will be replaced by a standby link, which maintains your intended bandwidth for the trunk. (See also the “Standby” entry under “Port Status” in table 9-9-6, “LACP Port Status Data”, on page 9-27.) In the next example, ports A1 through A5 have been configured for the same LACP trunk. Notice that one of the links shows Standby status, while the remaining four links are “Up”.



```

HPswitch> show lacp

```

		LACP					
		PORT	LACP	TRUNK	PORT	LACP	LACP
		NUMB	ENABLED	GROUP	STATUS	PARTNER	STATUS
		----	-----	-----	-----	-----	-----
"Up" Links	→	A1	Active	Dyn1	Up	Yes	Success
	→	A2	Active	Dyn1	Up	Yes	Success
	→	A3	Active	Dyn1	Up	Yes	Success
	→	A4	Active	Dyn1	Up	Yes	Success
Standby Link	→	A5	Active	Dyn1	Standby	Yes	Success

Figure 9-11. Example of a Dynamic LACP Trunk with One Standby Link

### Using the CLI To Configure a Static or Dynamic Trunk Group

#### Important

Configure port trunking *before* you connect the trunked links between switches. Otherwise, a broadcast storm could occur. (If you need to connect the ports before configuring them for trunking, you can temporarily disable the ports until the trunk is configured. See “Using the CLI To Configure Ports” on page 9-8.)

On the Series 4100GL switches you can configure up to six port trunk groups having up to four links each (with additional standby links if you’re using LACP). You can configure trunk group types as follows:

Trunk Type	Trunk Group Membership	
	TrkX (Static)	DynX (Dynamic)
LACP	Yes	Yes
Trunk	Yes	No
FEC	Yes	No

The following examples show how to create different types of trunk groups.

**Configuring a Static Trunk, Static FEC, or Static LACP Trunk Group.**

**Syntax:** trunk <trk1 | trk2 | trk3 | trk4 | trk5 | trk6 > <trunk | fec | lacp > <port-list>

This example uses ports C4 - C6 to create a non-protocol static trunk group with the group name of **Trk2**.

```
HPswitch(config)# trunk trk2 trunk c4-c6
```

**Removing Ports from a Static Trunk Group.** This command removes one or more ports from an existing **TrkX** trunk group.

---

**Caution**

---

Removing a port from a trunk can result in a loop and cause a broadcast storm. When you remove a port from a trunk where STP is not in use, HP recommends that you first disable the port or disconnect the link on that port.

**Syntax:** no trunk <port-list >

This example removes ports C4 and C5 from an existing trunk group.

```
HPswitch(config)# no trunk c4-c5
```

**Enabling a Dynamic LACP Trunk Group.** In the default port configuration, all ports on the switch are set to LACP **Passive**. However, to enable the switch to automatically form a trunk group that is dynamic on both ends of the link, the ports on one end of a set of links must be LACP **Active**. The ports on the other end can be either LACP **Active** or LACP **Passive**. This command enables the switch to automatically establish a (dynamic) LACP trunk group when the device on the other end of the link is configured for LACP **Passive**.

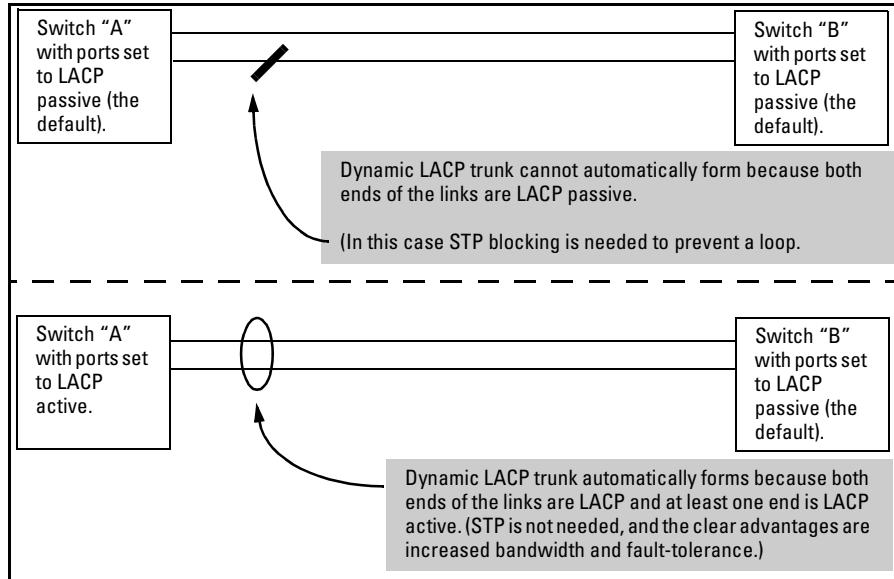

**Figure 9-12. Example of Criteria for Automatically Forming a Dynamic LACP Trunk**

**Syntax:** interface < port-list > lacp active

This example uses ports C4 and C5 to enable a dynamic LACP trunk group.

```
HPswitch(config)# interface c4-c5 lacp active
```

**Removing Ports from an Dynamic LACP Trunk Group.** To remove a port from dynamic LACP trunk operation, you must turn off LACP on the port. (On a port in an operating, dynamic LACP trunk, you cannot change between LACP **Active** and LACP **passive** without first removing LACP operation from the port.)

---

**Caution**

---

Unless STP is running on your network, removing a port from a trunk can result in a loop. To help prevent a broadcast storm when you remove a port from a trunk where STP is not in use, HP recommends that you first disable the port or disconnect the link on that port.

**Syntax:** no interface <port-list> lacp

In this example, port C6 belongs to an operating, dynamic LACP trunk. To remove port C6 from the dynamic trunk and return it to passive LACP, you would do the following:

```
HPswitch>(config)# no interface c6 lacp
HPswitch>(config)# interface c6 lacp passive
```

Note that in the above example, if the port on the other end of the link is configured for active LACP or static LACP, the trunked link will be re-established almost immediately.

## Web: Viewing Existing Port Trunk Groups

While the web browser interface does not enable you to configure a port trunk group, it does provide a view of an existing trunk group.

To view any port trunk groups:

Click on the **Status** tab.

Click on [Port Status](#).

## Trunk Group Operation Using LACP

The switch can automatically configure a dynamic LACP trunk group or you can manually configure a static LACP trunk group.

---

**Note**

---

LACP requires full-duplex (FDx) links of the same media type (10/100Base-T, 100FX, etc.) and the same speed, and enforces speed and duplex conformance across a trunk group.

LACP trunk status commands include:

Trunk Display Method	Static LACP Trunk	Dynamic LACP Trunk
CLI <b>show lacp</b> command	Included in listing.	Included in listing.
CLI <b>show trunk</b> command	Included in listing.	Not included.
Port/Trunk Settings screen in menu interface	Included in listing.	Not included

Thus, to display a listing of dynamic LACP trunk ports, you must use the **show lacp** command.

---

**Note**

---

Dynamic LACP trunks operate only in the default VLAN (unless GVRP is enabled and **Forbid** is used to prevent the trunked ports from joining the default VLAN). Thus, if an LACP dynamic port forms using ports that are not in the default VLAN, the trunk will automatically move to the default VLAN unless GVRP operation is configured to prevent this from occurring. In some cases, this can create a traffic loop in your network. For more on this topic, refer to “VLANs and Dynamic LACP” on page 9-29.

In most cases, trunks configured for LACP on the Series 4100GL switches operate as described in table 9-9-5 on the next page.

**Table 9-5. LACP Trunk Types**

LACP Port Trunk Configuration	Operation
Dynamic LACP	<p>This option automatically establishes an 802.3ad-compliant trunk group, with <b>LACP</b> for the port Type parameter and <b>DynX</b> for the port Group name, where <b>X</b> is an automatically assigned value from 1 to 6, depending on how many dynamic and static trunks are currently on the switch. (The switch allows a maximum of six trunk groups in any combination of static and dynamic trunks.)</p> <p>Under the following conditions, the switch automatically establishes a dynamic LACP port trunk group and assigns a port Group name:</p> <ul style="list-style-type: none"> <li>• The ports on both ends of a link have compatible mode settings (speed and duplex).</li> <li>• The port on one end of a link must be configured for LACP Active and the port on the other end of the same link must be configured for either LACP Passive (the default) or LACP Active. For example:</li> </ul>
<pre> graph LR     subgraph Switch1 [Switch 1]         direction TB         P1[Port X: LACP Enable: Active]         P2[Port Y: LACP Enable: Active]     end     subgraph Switch2 [Switch 2]         direction TB         P3[Port A: LACP Enable: Active]         P4[Port B: LACP Enable: Passive]     end     P1 --- Active-to-Active  P3     P2 --- Active-to-Passive  P4             </pre>	
<p>Either of the above link configurations allow a dynamic LACP trunk link.</p> <p><b>Standby Links:</b> A maximum of four operating links are allowed in the trunk, but, with dynamic LACP, you can configure one or more backup links that the switch automatically activates if a primary link fails. To configure a link as a standby for an existing four-port dynamic LACP trunk, ensure that the ports in the standby link are configured the same as either of the above examples.</p> <p><b>Displaying Dynamic LACP Trunk Data:</b> To list the configuration and status for a dynamic LACP trunk, use the CLI <b>show lacp</b> command.</p> <p><b>Note:</b> The dynamic trunk is automatically created by the switch, and is not listed in the static trunk listings available in the menu interface or in the CLI <b>show trunk</b> listing.</p>	
Static LACP	<p>The trunk operates if the trunk group on the opposite device is running one of the following trunking protocols:</p> <ul style="list-style-type: none"> <li>• Active LACP</li> <li>• Passive LACP</li> <li>• Trunk</li> <li>• FEC</li> </ul> <p>This option uses <b>LACP</b> for the port Type parameter and <b>TrkX</b> for the port Group parameter, where <b>X</b> is an automatically assigned value from 1 to 6, depending on how many static trunks are currently operating on the switch. (The switch allows a maximum of six trunk groups in any combination of static and dynamic trunks.)</p> <p>Displaying Static LACP Trunk Data: To list the configuration and status for a static LACP trunk, use the CLI <b>show lacp</b> command. To list a static LACP trunk with its assigned ports, use the CLI <b>show trunk</b> command or display the menu interface Port/Trunk Settings screen.</p> <p>Static LACP does not allow standby ports.</p>

## Default Port Operation

In the default configuration, all ports are configured for passive LACP. However, if LACP is not configured, the port will not try to detect a trunk configuration and will operate as a standard, untrunked port. The following table describes the elements of per-port LACP operation. To display this data for a particular switch, execute the following command in the CLI:

```
HPswitch> show lacp
```

**Table 9-6. LACP Port Status Data**

Status Name	Meaning
Port Numb	Shows the physical port number for each port configured for LACP operation (C1, C2, C3 . . .). Unlisted port numbers indicate that the missing ports are assigned to a static Trunk group, an FEC trunk group, or are not configured for any trunking.
LACP Enabled	<p><b>Active:</b> The port automatically sends LACP protocol packets.</p> <p><b>Passive:</b> The port does not automatically send LACP protocol packets, and responds only if it receives LACP protocol packets from the opposite device.</p> <p>A link having either two active LACP ports or one active port and one passive port can perform dynamic LACP trunking. A link having two passive LACP ports will not perform LACP trunking because both ports are waiting for an LACP protocol packet from the opposite device.</p> <p><b>Note:</b> In the default switch configuration, all ports are configured for passive LACP operation.</p>
Trunk Group	<p><b>TrkX:</b> This port has been manually configured into a static LACP trunk.</p> <p><b>Trunk Group Same as Port Number:</b> The port is configured for LACP, but is not a member of a port trunk.</p>
Port Status	<p><b>Up:</b> The port has an active LACP link and is not blocked or in Standby mode.</p> <p><b>Down:</b> The port is enabled, but an LACP link is not established. This can indicate, for example, a port that is not connected to the network or a speed mismatch between a pair of linked ports.</p> <p><b>Disabled:</b> The port cannot carry traffic.</p> <p><b>Blocked:</b> LACP, STP, or FEC has blocked the port. (The port is not in LACP Standby mode.) This may be due to a trunk negotiation (very brief) or a configuration error such as differing port speeds on the same link or attempting to connect the Series 4100GL switches to more than six trunks.</p> <p><b>Standby:</b> The port is configured for dynamic LACP trunking to another device, but the maximum number of ports for the Dynamic trunkto that device has already been reached on either the Series 4100GL switches or the other device. This port will remain in reserve, or “standby” unless LACP detects that another, active link in the trunk has become disabled, blocked, or down. In this case, LACP automatically assigns a Standby port, if available, to replace the failed port.</p>
LACP Partner	<p><b>Yes:</b> LACP is enabled on both ends of the link.</p> <p><b>No:</b> LACP is enabled on the Series 4100GL switches, but either LACP is not enabled or the link has not been detected on the opposite device.</p>
LACP Status	<p><b>Success:</b> LACP is enabled on the port, detects and synchronizes with a device on the other end of the link, and can move traffic across the link.</p> <p><b>Failure:</b> LACP is enabled on a port and detects a device on the other end of the link, but is not able to synchronize with this device, and therefore not able to send LACP packets across the link. This can be caused, for example, by an intervening device on the link (such as a hub), a bad hardware connection, or if the LACP operation on the opposite device does not comply with the IEEE 802.3ad standard.</p>

## LACP Notes and Restrictions

**802.1x (Port-Based Access Control) Configured on a Port.** To maintain security, LACP is not allowed on ports configured for 802.1x authenticator operation. If you configure port security on a port on which LACP (active or passive) is configured, the switch removes the LACP configuration, displays a notice that LACP is disabled on the port(s), and enables 802.1x on that port.

```
HPswitch(config)# aaa port-access authenticator e b1  
LACP has been disabled on 802.1x port(s).  
HPswitch(config)#
```

The switch will not allow you to configure LACP on a port on which port access (802.1x) is enabled. For example:

```
HPswitch(config)# int e b1 lacp passive  
Error configuring port < port-number >: LACP and 802.1x  
cannot be run together.  
HPswitch(config)#
```

To restore LACP to the port, you must first remove the port's 802.1x configuration and then re-enable LACP active or passive on the port.

**Port Security Configured on a Port.** To maintain security, LACP is not allowed on ports configured for port security. If you configure port security on a port on which LACP (active or passive) is configured, the switch removes the LACP configuration, displays a notice that LACP is disabled on the port(s), and enables port security on that port. For example:

```
HPswitch(config)# port-security e a17 learn-mode static  
address-limit 2  
LACP has been disabled on secured port(s).  
HPswitch(config)#
```

The switch will not allow you to configure LACP on a port on which port security is enabled. For example:

```
HPswitch(config)# int e a17 lacp passive  
Error configuring port A17: LACP and port security cannot  
be run together.  
HPswitch(config)#
```

To restore LACP to the port, you must remove port security and re-enable LACP active or passive.



**Changing Trunking Methods.** To convert a trunk from static to dynamic, you must first eliminate the static trunk.

**Static LACP Trunks.** Where a port is configured for LACP (Active or Passive), but does not belong to an existing trunk group, you can add that port to a static trunk. Doing so disables dynamic LACP on that port, which means you must manually configure both ends of the trunk.

**Dynamic LACP Trunks.** You can configure a port for LACP-active or LACP-passive, but on a dynamic LACP trunk you cannot configure the other options that you can on static trunks. If you want to manually configure a trunk, use the **trunk** command. (Refer to “Using the CLI To Configure a Static or Dynamic Trunk Group” on page 9-21.)

**VLANs and Dynamic LACP.** A dynamic LACP trunk operates only in the default VLAN (unless you have enabled GVRP on the switch and use **Forbid** to prevent the ports from joining the default VLAN).

- If you want to use LACP for a trunk on a non-default VLAN and GVRP is disabled, configure the trunk as a static trunk.
- If there are ports that you do not want on the default VLAN, ensure that they cannot become dynamic LACP trunk members. Otherwise a traffic loop can unexpectedly occur. For example:

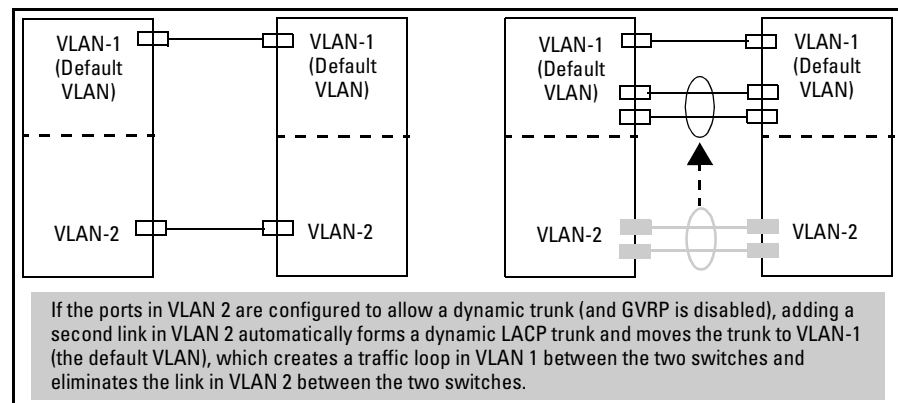

**Figure 9-13. A Dynamic LACP Trunk Forming in a VLAN Can Cause a Traffic Loop**

Easy control methods include either disabling LACP on the selected ports or configuring them to operate in static LACP trunks.

**STP and IGMP.** If spanning tree (STP) and/or IGMP is enabled in the switch, a dynamic LACP trunk operates only with the default settings for these features and does not appear in the port listings for these features.

### **Half-Duplex and/or Different Port Speeds Not Allowed in LACP**

**Trunks.** The ports on both sides of an LACP trunk must be configured for the same speed and for full-duplex (FDx). The 802.3ad LACP standard specifies a full-duplex (FDx) requirement for LACP trunking.

A port configured as LACP passive and not assigned to a port trunk can be configured to half-duplex (HDx). However, in any of the following cases, a port cannot be reconfigured to an HDx setting:

- If a port is set to LACP Active, you cannot configure it to HDx.
- If a port is already a member of a static or dynamic LACP trunk, you cannot configure it to HDx.
- If a port is already set to HDx, the switch does not allow you to configure it for a static or dynamic LACP trunk.

**Dynamic/Static LACP Interoperation:** A port configured for dynamic LACP can properly interoperate with a port configured for static (TrkX) LACP, but any ports configured as standby LACP links will be ignored.

## Trunk Group Operation Using the “Trunk” Option

This method creates a trunk group that operates independently of specific trunking protocols and does not use a protocol exchange with the device on the other end of the trunk. With this choice, the switch simply uses the SA/DA method of distributing outbound traffic across the trunked ports without regard for how that traffic is handled by the device at the other end of the trunked links. Similarly, the switch handles incoming traffic from the trunked links as if it were from a trunked source.

Use the Trunk option when you are trying to establish a trunk group between a Series 4100GL switch and another device, but the other device’s trunking operation fails to interoperate properly with LACP or FEC trunking configured on the Series 4100GL switches.

## Trunk Operation Using the “FEC” Option

This is the most flexible method for distributing traffic over trunked links when connecting to devices that use the FEC (Fast EtherChannel<sup>®</sup>) technology. FEC trunks offer the following benefits:

- Provide trunked connectivity to a FEC-compliant server, switch, or router.
- Enable quick convergence to remaining links when a failure is detected on a trunked port link.

- Depending on the capabilities of the device on the other end of the trunk, negotiate the forwarding mechanism on the trunk to the non-protocol option.
- When auto-negotiated to the SA/DA forwarding mechanism, provide higher performance on the trunk for broadcast, multicast, and flooded traffic through distribution in the same manner as non-protocol trunking.
- Support FEC automatic trunk configuration mode on other devices. That is, when connecting FEC trunks to FEC-capable servers, switches, or routers having FEC automatic trunk configuration mode enabled, the FEC trunks allow these other devices to automatically form trunk groups.

## How the Switch Lists Trunk Data

Static Trunk Group: Appears in the menu interface and the output from the CLI **show trunk** and **show interfaces** commands.

Dynamic LACP Trunk Group: Appears in the output from the CLI **show lacp** command.

Interface Option	Dynamic LACP Trunk Group	Static LACP Trunk Group	Static Non-Protocol or FEC Trunk Group
Menu Interface	No	Yes	Yes
CLI <b>show trunk</b>	No	Yes	Yes
CLI <b>show interfaces</b>	No	Yes	Yes
CLI <b>show lacp</b>	Yes	Yes	No
CLI <b>show spanning-tree</b>	No	Yes	Yes
CLI <b>show igmp</b>	No	Yes	Yes
CLI <b>show config</b>	No	Yes	Yes

## Outbound Traffic Distribution Across Trunked Links

All three trunk group options (LACP, Trunk, and FEC) use source-destination address pairs (SA/DA) for distributing outbound traffic over trunked links.

SA/DA (source address/destination address) causes the switch to distribute outbound traffic to the links within the trunk group on the basis of source/destination address pairs. That is, the switch sends traffic from the same

source address to the same destination address through the same trunked link, and sends traffic from the same source address to a different destination address through a different link, depending on the rotation of path assignments among the links in the trunk. Likewise, the switch distributes traffic for the same destination address but from different source addresses through different links. Because the amount of traffic coming from or going to various nodes in a network can vary widely, it is possible for one link in a trunk group to be fully utilized while others in the same trunk have unused bandwidth capacity even though the address assignments are evenly distributed across the links in a trunk. In actual networking environments, this is rarely a problem. However, if it becomes a problem, you can use the HP TopTools for Hubs & Switches network management software available from Hewlett-Packard to quickly and easily identify the sources of heavy traffic (top talkers) and make adjustments to improve performance.

Broadcasts, multicasts, and floods from different source addresses are distributed evenly across the links. As links are added or deleted, the switch redistributes traffic across the trunk group. For example, in figure 9-9-14 showing a three-port trunk, traffic could be assigned as shown in table 9-9-7.

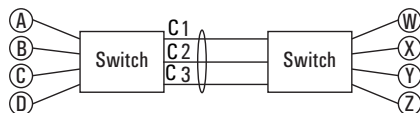

**Figure 9-14. Example of Port-Trunked Network**

**Table 9-7. Example of Link Assignments in a Trunk Group (SA/DA Distribution)**

Source:	Destination:	Link:
Node A	Node W	1
Node B	Node X	2
Node C	Node Y	3
Node D	Node Z	1
Node A	Node Y	2
Node B	Node W	3

## Configuring Port-Based Priority for Incoming Packets

Feature	Default	Menu	CLI	Web
Assigning a priority level to traffic on the basis of incoming port	Disabled	n/a	page 9-36	n/a

When network congestion occurs, it is important to move traffic on the basis of relative importance. However, without prioritization:

- Traffic from less important sources can consume bandwidth and slow down or halt delivery of more important traffic.
- Most traffic from all ports is forwarded as normal priority, and competes for bandwidth with all other normal-priority traffic, regardless of its relative importance.

Traffic received in tagged VLAN packets carries a specific 802.1p priority level (0 - 7) that the switch recognizes and uses to assign packet priority at the outbound port. With the default port-based priority, the switch handles traffic received in untagged packets as "Normal" (priority level = 0).

You can assign a priority level to:

- Inbound, untagged VLAN packets
- Inbound, tagged VLAN packets having a priority level of 0 (zero)

(The switch does not alter the existing priority level of inbound, tagged VLAN packets carrying a priority level of 1-7.)

Thus, for example, high-priority tagged VLAN traffic received on a port retains its priority in the switch. However, you have the option of configuring the port to assign a priority level to untagged traffic and 0-priority tagged traffic the port receives.

### The Role of 802.1Q VLAN Tagging

An 802.1Q-tagged VLAN packet carries the packet's VLAN assignment and the 802.1p priority setting (0 - 7). (By contrast, an untagged packet does not have a tag and does not carry a priority setting.) Generally, the switch preserves and uses a packet's priority setting to determine which outbound queue the packet belongs in on the outbound port. If the outbound port is a tagged

member of the VLAN, the packet carries its priority setting to the next, downstream device. If the outbound port is not configured as a tagged member of the VLAN, then the tag is stripped from the packet, which then exits from the switch without a priority setting.

## Outbound Port Queues and Packet Priority Settings

Switch 4108GL ports use three outbound port queues, *Low*, *Normal*, and *High*. As described below, these three queues map to the eight priority settings specified in the 802.1p standard.

**Table 9-8. Mapping Priority Settings to Device Queues**

802.1p Priority Settings Used In Tagged VLAN Packets	Series 4100GL and Other Devices with 3 Outbound Port Queues	Queue Assignment in Downstream Devices With:		
		4 Queues	8 Queues	2 Queues
1 (low)	Low	1	1	1
2 (low)	Low	1	2	1
0 (normal priority)	Normal	2	3	1
3	Normal	2	4	1
4	High	3	5	2
5	High	3	6	2
6	High	4	7	2
7 (high priority)	High	4	8	2

For example, suppose you have configured port A10 to assign a priority level of 1 (low):

- An untagged packet coming into the switch on port A10 and leaving the switch through any other port configured as a tagged VLAN member would leave the switch as a tagged packet with a priority level of 1.
- A tagged packet with an 802.1p priority setting of 0 (zero) coming into the switch on port A10 and leaving the switch through any other port configured as a tagged VLAN member would leave the switch as a tagged packet with a priority level of 1.
- A tagged packet with an 802.1p priority setting (1 - 7) coming into the switch on port A10 and leaving the switch through any other port configured as a tagged VLAN member would keep its original priority setting (regardless of the port-based priority setting on port A10).

---

**Note**

---

For a packet to carry a given 802.1p priority level from end-to-end in a network, the VLAN for the packet must be configured as tagged on all switch-to-switch links. Otherwise the tag is removed and the 802.1p priority is lost as the packet moves from one switch to the next.

### Operating Rules for Port-Based Priority on Series 4100GL Switches

- In the switch's default configuration, port-based priority is configured as "0" (zero) for inbound traffic on all ports.
- On a given port, when port-based priority is configured as 0 - 7, an inbound, *untagged* packet adopts the specified priority and is sent to the corresponding outbound queue on the outbound port. (See table 9-8, "Mapping Priority Settings to Device Queues", on page 34.) If the outbound port is a tagged member of the applicable VLAN, then the packet carries a tag with that priority setting to the next downstream device.
- On a given port, when port-based priority is configured as 0 - 7, an inbound, *tagged* packet with a priority of 0 (zero) adopts the specified priority and is sent to the corresponding outbound queue on the outbound port. (See table 9-8, "Mapping Priority Settings to Device Queues", on page 34.) If the outbound port is a tagged member of the applicable VLAN, then the packet carries a tag with that priority setting to the next downstream device.
- On a given port, an inbound, *tagged* packet received on the port with a preset priority of 0 - 7 in its tag keeps that priority. It is assigned an outbound queue on the basis of that priority (regardless of the port-based priority configured on the port). (Refer to table 9-8, "Mapping Priority Settings to Device Queues" on page 9-34.)
- If a packet leaves the switch through an outbound port configured as an untagged member of the packet's VLAN, then the packet leaves the switch without a VLAN tag and thus without an 802.1p priority setting.
- Trunked ports do not allow non-default (1 - 7) port-based priority settings. If you configure a non-default port-based priority value on a port and then add the port to a port trunk, then the port-based priority for that port is returned to the default "0".

## Configuring and Viewing Port-Based Priority

This command enables or disables port-based priority on a per-port basis. You can either enter the command on the interface context level or include the interface in the command.

**Syntax:** qos priority < 1 - 7 >

*Configures a non-default port-based 802.1p priority for incoming, untagged packets or tagged packets arriving with a "0" priority on the designated ports, as described under "Operating Rules for Port-Based Priority", above.*

qos priority 0

*Returns a port-based priority setting to the default "0" for untagged packets received on the designated port(s). In this state the switch handles the untagged packets with "Normal" priority. (Refer to 9-8 on page 9-34.)*

show running-config

*Lists any non-default (1 - 7) port-based priority settings in the running-config file on a per-port basis. If the priority is set to the (default) "0", the setting is not included in the **show config** listing.*

show config

*Lists any non-default (1 - 7) port-based priority settings in the startup-config file on a per-port basis. If the priority is set to the (default) "0", the setting is not included in the **show config** listing.*

For example, suppose you wanted to configure ports A10 -A12 on the switch to prioritize all untagged, inbound VLAN traffic as "Low" (priority level = 1; refer to table 9-8 on page 9-34).



```

HPswitch(config)# interface e A9-A12 qos priority 1
HPswitch(config)# write mem
HPswitch(config)# show config

Startup configuration:

; J4865A Configuration Editor; Created on release #G.04.04

hostname "HPswitch"
time daylight-time-rule None
cdp run
interface A9
|   qos priority 1
|   exit
interface A10
|   qos priority 1
|   exit
interface A11
|   qos priority 1
|   exit
interface A12
|   qos priority 1
|   exit
-----
snmp-server community "public" Unrestricted
vlan 1
  name "DEFAULT_VLAN"
-- MORE --, next page: Space, next line: Enter, quit: Control-C
    
```

Configures port-based priority on ports A9 -A12 to "1" (Low) and saves the configuration changes to the startup-config file.

Ports A9 - A12 are now configured to assign a priority level of "1" (Low) to untagged, incoming traffic. (Any inbound, tagged traffic retains its priority level while transiting the switch.)

Figure 9-15. Example of Configuring Non-Default Prioritization on Untagged, Inbound Traffic

### Messages Related to Prioritization

Message	Meaning
< <i>priority-level</i> >: Unable to create.	The port(s) on which you are trying to configure a qos priority may belong to a port trunk. Trunked ports cannot be configured for qos priority.

### Troubleshooting Prioritization

Refer to "Prioritization Problems" on page C-7 in the "Troubleshooting" chapter.

**Optimizing Traffic Flow with Port Controls, Port Trunking, and Port-Based Priority**  
Configuring Port-Based Priority for Incoming Packets

# Configuring for Network Management Applications

---

## Contents

<b>Using SNMP Tools To Manage the Switch</b> .....	10-2
Overview .....	10-2
SNMP Management Features .....	10-3
Configuring for SNMP Access to the Switch .....	10-3
SNMP Communities .....	10-4
Menu: Viewing and Configuring SNMP Communities .....	10-4
CLI: Viewing and Configuring Community Names .....	10-6
Trap Receivers and Authentication Traps .....	10-8
Advanced Management: RMON .....	10-12
<b>CDP</b> .....	10-13
Introduction .....	10-13
CDP Terminology .....	10-14
General CDP Operation .....	10-15
Outgoing Packets .....	10-15
Incoming CDP Packets .....	10-16
Configuring CDP on the Switch .....	10-19
Viewing the Switch's Current CDP Configuration .....	10-20
Viewing the Switch's Current CDP Neighbors Table .....	10-20
Clearing (Resetting) the CDP Neighbors Table .....	10-21
Configuring CDP Operation .....	10-22
Effect of Spanning Tree (STP) On CDP Packet Transmission ....	10-24
How the Switch Selects the IP Address To Include in	
Outbound CDP Packets .....	10-25
CDP Neighbor Data and MIB Objects .....	10-26
Operating Notes .....	10-28

# Using SNMP Tools To Manage the Switch

## Overview

You can manage the switch via SNMP from a network management station, including HP TopTools for Hubs & Switches — an OpenView-based network management application that runs on your Windows NT- or Windows 2000-based PC. HP TopTools for Hubs & Switches provides control of your switch through its web browser interface. In addition, it uses the RMON agent statistical sampling software that is included in the switch to provide easy-to-use traffic monitoring and network activity analysis tools. For more on TopTools, see the "Read Me First" document shipped with your switch and also available on HP's Procurve website at

**<http://www.hp.com/go/hpprocurve>**

This section includes:

- An overview of SNMP management for the switch
- Configuring the switches for:
  - SNMP Communities (page 10-4)
  - Trap Receivers and Authentication Traps (page 10-8)
- Information on advanced management through RMON Support (page 10-12)

To implement SNMP management, the switch must have an IP address, configured either manually or dynamically (with DHCP or Bootp). If multiple VLANs are configured, each VLAN interface should have its own IP address. For DHCP use with multiple VLANs, see "The Primary VLAN" on page 11-6.

---

### **Note**

If you use the switch's Authorized IP Managers and Management VLAN features, ensure that the SNMP management station and/or the choice of switch port used for SNMP access to the switch are compatible with the access controls enforced by these features. Otherwise, SNMP access to the switch will be blocked. For more on Authorized IP Managers, refer to the Access Security Guide on the Documentation CD-ROM shipped with your switch and also available on the HP Procurve website. For information on the Management VLAN feature, refer to "The Secure Management VLAN" on page 11-26.

---

## SNMP Management Features

SNMP management features on the switch include:

- SNMP version 2c over IP
- Security via configuration of SNMP communities (page 10-3)
- Event reporting via SNMP
  - Version 1 traps
  - RMON: groups 1, 2, 3, and 9
- Managing the switch with an SNMP network management tool such as HP TopTools for Hubs & Switches
- Standard MIBs, such as the Bridge MIB (RFC 1493), Ethernet MAU MIB (RFC 1515), and others.

The switch SNMP agent also uses certain variables that are included in a Hewlett-Packard proprietary MIB (Management Information Base) file. To ensure that you have the latest version in the database of your TopTools, OpenView, or other SNMP network management tool, you can copy the MIB file from the HP Procurve World Wide Web site at:

**<http://www.hp.com/go/hpprocurve>**

Click on **software**, then **MIBs**.

## Configuring for SNMP Access to the Switch

SNMP access requires an IP address and subnet mask configured on the switch. (See “IP Configuration” on page 7-3.) If you are using DHCP/Bootp to configure the switch, ensure that the DHCP/Bootp process provides the IP address. (See “DHCP/Bootp Operation” on page 7-10.)

Once an IP address has been configured, the main steps for configuring for SNMP access to management features are:

1. Configure the appropriate SNMP communities. (Refer to “SNMP Communities” on page 10-4.)
2. Configure the appropriate trap receivers. (Refer to “Trap Receivers and Authentication Traps” on page 10-8.)

In some networks, authorized IP manager addresses are not used. In this case, all management stations using the correct community name may access the switch with the View and Access levels that have been set for that community. If you want to restrict access to one or more specific nodes, you can use the switch’s IP Authorized Manager feature. (Refer to the *Access Security Guide* for your switch.)

---

**Caution**

The “public” community exists by default and is used by HP’s network management applications. Deleting the “public” community disables many network management functions (such as auto-discovery, traffic monitoring, SNMP trap generation, and threshold setting). If security for network management is a concern, it is recommended that you change the write access for the “public” community to “Restricted”.

---

## SNMP Communities

### SNMP Community Features

Feature	Default	Menu	CLI	Web
show SNMP communities	n/a	page 10-4	page 10-6	—
configure identity information	none	—	page 10-7	
configure community names	public	page 10-4	page 10-7	—
MIB view for a community name (operator, manager)	manager	"	"	
write access for default community name	unrestricted	"	"	

---

Use SNMP communities to restrict access to the switch by SNMP management stations by adding, editing, or deleting SNMP communities. You can configure up to five SNMP communities, each with either an operator-level or a manager-level view, and either restricted or unrestricted write access.

Using SNMP requires that the switch have an IP address and subnet mask compatible with your network.

---

**Caution**

Deleting or changing the community named “public” prevents network management applications (such as auto-discovery, traffic monitoring, SNMP trap generation, and threshold setting) from operating in the switch. (Changing or deleting the “public” name also generates an Event Log message.) If security for network management is a concern, it is recommended that you change the write access for the “public” community to “Restricted”.

---

## Menu: Viewing and Configuring SNMP Communities

### To View, Edit, or Add SNMP Communities:

1. From the Main Menu, Select:
  2. Switch Configuration...
  6. SNMP Community Names

**Note:** This screen gives an overview of the SNMP communities that are currently configured. All fields in this screen are read-only.

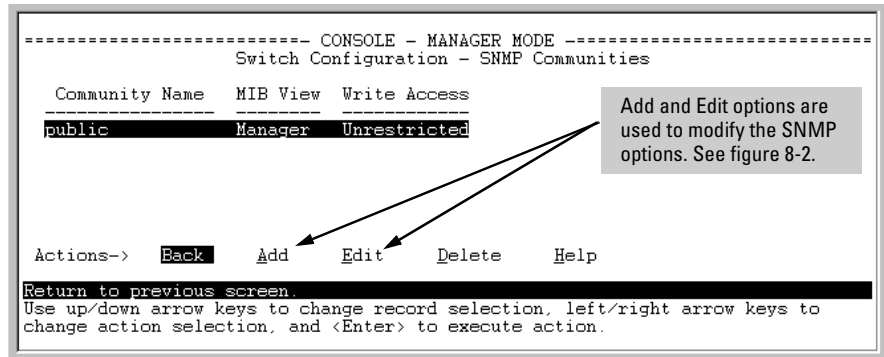
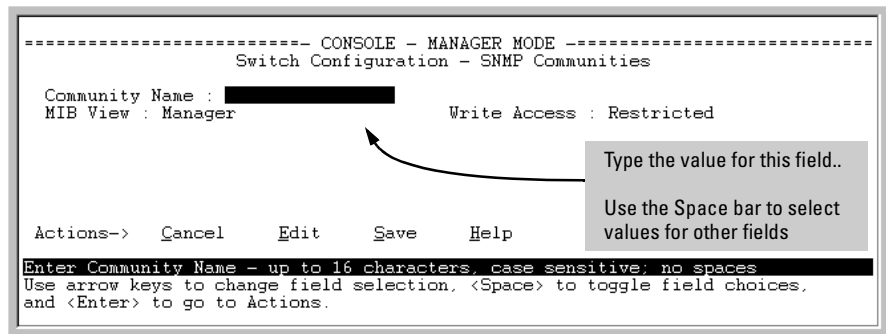

**Figure 10-1. The SNMP Communities Screen (Default Values)**

2. Press **[A]** (for **Add**) to display the following screen:

If you are adding a community, the fields in this screen are blank.

If you are editing an existing community, the values for the currently selected Community appear in the fields.



**Figure 10-2. The SNMP Add or Edit Screen**

**Need Help?** If you need information on the options in each field, press **[Enter]** to move the cursor to the Actions line, then select the **Help** option on the Actions line. When you are finished with Help, press **[E]** (for **Edit**) to return the cursor to the parameter fields.

3. Enter the name you want in the Community Name field, and use the Space bar to select the appropriate value in each of the other fields. (Use the **[Tab]** key to move from one field to the next.)
4. Press **[Enter]**, then **[S]** (for **Save**).

## CLI: Viewing and Configuring Community Names

Community Name Commands	Page
show snmp-server [<community-string>]	10-6
[no] snmp-server	10-7
[community <community-str>]	10-7
[host <community-str> <ip-addr>]	10-10
[<none   debug   all   not-info   critical>]	
[enable traps <authentication>]	10-11

**Listing Community Names and Values.** This command lists the data for currently configured SNMP community names (along with trap receivers and the setting for authentication traps — see “Trap Receivers and Authentication Traps” on page 10-8).

**Syntax:** show snmp-server [<community-string>]

This example lists the data for all communities in a switch; that is, both the default HPswitch "public" community name and another community named "red-team"

```

HPswitch# show snmp-server

SNMP Communities

Community Name      MIB View  Write Access
-----
public              Manager   Unrestricted
blue-team           Operator  Restricted

Trap Receivers

Send Authentication Traps [No] : No

Address              Community  Events Sent in Trap
-----
  
```

The diagram shows three callout boxes on the left with arrows pointing to specific parts of the CLI output:

- Default Community and Settings:** Points to the 'public' community entry in the 'SNMP Communities' table.
- Non-Default Community and Settings:** Points to the 'blue-team' community entry in the 'SNMP Communities' table.
- Trap Receiver Data (See page 10-8.):** Points to the 'Trap Receivers' section of the output.

**Figure 10-3. Example of the SNMP Community Listing with Two Communities**

To list the data for only one community, such as the "public" community, use the above command with the community name included. For example:

```
HPswitch# show snmp-server public
```



**Configuring Community Names and Values.** The `snmp-server` command enables you to add SNMP communities with either default or specific access attributes, and to delete specific communities.

**Syntax:** [ no ] `snmp-server community < community-name >`

*Configures a new community name. If you do not also specify **operator** or **manager**, the switch automatically assigns the community to the **operator** MIB view. If you do not specify **restricted** or **unrestricted**, the switch automatically assigns the community to **restricted** (read-only) access. The **no** form uses only the **< community-name >** variable and deletes the named community from the switch.*

[ operator | manager ]

*Optionally assigns an access level. At the **operator** level the community can access all MIB objects except the CONFIG MIB. At the **manager** level the community can access all MIB objects.*

[ restricted | unrestricted ]

*Optionally assigns MIB access type. Assigning the **restricted** type allows the community to read MIB variables, but not to set them. Assigning the **unrestricted** type allows the community to read and set MIB variables.*

For example, to add the following communities:

Community	Access Level	Type of Access
red-team	manager <i>(Access to all MIB objects.)</i>	unrestricted <i>(read/write)</i>
blue-team	operator <i>(Access to all MIB objects except the CONFIG MIB.)</i>	restricted <i>(read-only)</i>

```
HPswitch(config)# snmp-server community red-team  
manager unrestricted
```

```
HPswitch(config)# snmp-server community blue-team  
operator restricted
```

To eliminate a previously configured community named "gold-team":

```
HPswitch(config) # no snmp-server community gold-team
```

## Trap Receivers and Authentication Traps

### Trap Features

Feature	Default	Menu	CLI	Web
snmp-server host (trap receiver)	public	—	page 10-10	—
snmp-server enable (authentication trap)	none	—	page 10-11	—

A *trap receiver* is a management station designated by the switch to receive SNMP traps sent from the switch. An *authentication trap* is a specialized SNMP trap sent to trap receivers when an unauthorized management station tries to access the switch.

---

### Note

**Fixed or "Well-Known" Traps:** The Series 4100GL switches automatically sends fixed traps (such as "coldStart", "warmStart", "linkDown", and "linkUp") to trap receivers using the **public** community name. These traps cannot be redirected to other communities. Thus, if you change or delete the default **public** community name, these traps will be lost.

**Thresholds:** The switch automatically sends all messages resulting from thresholds to the network management station(s) that set the thresholds, regardless of the trap receiver configuration.

---

In the default configuration, there are no trap receivers configured, and the authentication trap feature is disabled. From the CLI you can configure up to ten SNMP trap receivers to receive SNMP traps from the switch. As an option, you can also configure the switch to send Event Log messages as traps. CLI: Configuring and Displaying Trap Receivers

---

Trap Receiver Commands	Page
show snmp-server	10-9
snmp-server host <ip-addr> <community-name> [none   all   non-inform   critical   debug]	10-10
snmp-server enable traps authentication	10-10

---

### Using the CLI To List Current SNMP Trap Receivers.

This command lists the currently configured trap receivers and the setting for authentication traps (along with the current SNMP community name data — see “SNMP Communities” on page 10-4).

**Syntax:** show snmp-server

*Displays current community and trap receiver data.*

In the next example, the **show snmp-server** command shows that the switch has been previously configured to send SNMP traps to management stations belonging to the “public”, “red-team”, and “blue-team” communities.

```
HPswitch# show snmp-server
```

SNMP Communities			
Community Name	MIB View	Write	Access
public	Operator	Restricted	
blue-team	Manager	Unrestricted	
red-team	Manager	Unrestricted	

Send Authentication Traps : No

Address	Community	Events Sent in Trap
10.28.227.200	public	All
10.28.227.105	red-team	Critical
10.28.227.120	blue-team	Not-INFO

Example of Community Name Data (See page 10-4.)

Example of Trap Receiver Data

Authentication Trap Setting

Figure 10-4. Example of Show SNMP-Server Listing

**Configuring Trap Receivers.** This command specifies trap receivers by community membership, management station IP address, and the type of Event Log messages to send to the trap receiver.

---

**Note**

---

If you specify a community name that does not exist—that is, has not yet been configured on the switch—the switch still accepts the trap receiver assignment. However, no traps will be sent to that trap receiver until the community to which it belongs has been configured on the switch.

**Syntax:** snmp-server host < community-string > < ip-address >

*Using community name and destination IP address, this command designates a destination network-management station for receiving SNMP event log messages from the switch. If you do not specify the event level, then the switch does not send event log messages as traps. You can specify up to 10 trap receivers (network management stations).*

**Note:** *In all cases, the switch sends any threshold trap(s) to the network management station(s) that explicitly set the threshold(s).*

[<none | all | non-info | critical | debug>]

*Options for sending switch Event Log messages to a trap receiver. Refer to Table 10-1, “Options for Sending Event Log Messages as Traps,” on page 10-10. The levels specified with these options apply only to Event Log messages, and not to threshold traps.*

**Table 10-1. Options for Sending Event Log Messages as Traps**

Event Level	Description
None (default)	Send no log messages.
All	Send all log messages.
Not INFO	Send the log messages that are not information-only.
Critical	Send critical-level log messages.
Debug	Reserved for HP-internal use.

For example, to configure a trap receiver in a community named "red-team" with an IP address of 10.28.227.130 to receive only "critical" log messages:

```
HPswitch(config)# snmp-server trap-receiver red-team  
10.28.227.130 critical
```

---

## Notes

To replace one community name with another for the same IP address, you must use **no snmp-server host < community-name> < ip-address >** to delete the unwanted community name. Otherwise, adding a new community name with an IP address already in use with another community name simply creates two allowable community name entries for the same management station.

If you do not specify the event level ([<none | all | non-info | critical | debug>]) then the switch does not send event log messages as traps. "Well-Known" traps and threshold traps (if configured) will still be sent..

---

## Using the CLI To Enable Authentication Traps

---

### Note

For this feature to operate, one or more trap receivers must be configured on the switch. See "In the default configuration, there are no trap receivers configured, and the authentication trap feature is disabled. From the CLI you can configure up to ten SNMP trap receivers to receive SNMP traps from the switch. As an option, you can also configure the switch to send Event Log messages as traps. CLI: Configuring and Displaying Trap Receivers" on page 10-8.

---

### Using the CLI To Enable Authentication Traps.

**Syntax:** [no] snmp-server enable traps authentication

*Enables or disables sending an authentication trap to the configured trap receiver(s) if an unauthorized management station attempts to access the switch.*

---

For example:

```
HPswitch(config)# snmp-server enable traps authentication
```

Check the Event Log in the console interface to help determine why the authentication trap was sent. (Refer to "Using the Event Log To Identify Problem Sources" on page C-21.)

## Advanced Management: RMON

The switch supports RMON (Remote Monitoring) on all connected network segments. This allows for troubleshooting and optimizing your network.

The following RMON groups are supported:

- Ethernet Statistics (except the numbers of packets of different frame sizes)
- Alarm
- History (of the supported Ethernet statistics)
- Event

The RMON agent automatically runs in the switch. Use the RMON management station on your network to enable or disable specific RMON traps and events. Note that you can access the Ethernet statistics, Alarm, and Event groups from the HP TopTools for Hubs & Switches network management software. For more on TopTools, see the "Read Me First" document shipped with your switch and also available on HP's ProCurve website at

**<http://www.hp.com/go/hpprocurve>**

# CDP

## CDP Features

Feature	Default	Menu	CLI	Web
view the switch's CDP configuration	n/a	—	page 10-20	—
view the switch's CDP Neighbors table	n/a	—	page 10-20	—
clear (reset) the CDP Neighbors table	n/a	—	page 10-21	—
enable or disable CDP on the switch	enabled	—	page 10-22	—
enable or disable CDP operation on an individual port	enabled	—	page 10-23	—
change the transmit interval for the switch's CDP packets	60 seconds	—	page 10-24	—
change the hold time (time-to-live for CDP packets the switch generates)	180 seconds	—	page 10-24	—

## Introduction

In Series 4100GL switches, CDP-v1 (Cisco Discovery Protocol, version 1) provides data that aids SNMP-based network mapping utilities designed to discover devices running CDP in a network. To make this data available, the switch transmits information about itself via CDP packets to adjacent devices, and also receives and stores information about adjacent devices running CDP. This enables each CDP device to receive and maintain identity data on each of its CDP neighbors and pass this information off to an SNMP utility designed to query the CDP area of the device's MIB.

### Note

To take advantage of CDP in Series 4100GL switches, you should have a working knowledge of SNMP operation and an SNMP utility capable of polling the switches for CDP data. HP's implementation of CDP places specific data into the switch's Management Information Base (MIB). However, retrieval of this data for network mapping is dependent on the operation of your SNMP utility. Refer to the documentation provided with the utility.

An SNMP utility can progressively discover CDP devices in a network by:

1. Reading a given device's CDP Neighbor table (in the Management Information Base, or MIB) to learn about other, neighbor CDP devices
2. Using the information learned in step 1 to go to and read the neighbor devices' CDP Neighbors tables to learn about additional CDP devices, and so on

This section describes CDP operation in a Series 4100GL switches. For information on how to use an SNMP utility to retrieve the CDP information from the switch's CDP Neighbors table (in the switch's MIB), refer to the documentation provided with the particular SNMP utility. For information on the object identifiers in the CDP MIB, see "CDP Neighbor Data and MIB Objects" on page 10-26.

## CDP Terminology

- **CDP Device:** A switch, server, router, workstation, or other device running CDP.
- **CDP-Aware:** A device that has CDP in its operating code (with CDP either enabled or disabled in that device).
- **CDP-Disabled:** A CDP-aware device on which CDP is currently disabled.
- **Non-CDP Device:** A device that does not have CDP in its operating code.
- **CDP Neighbor:** A CDP device that is either directly connected to another CDP device or connected to that device by a non-CDP device, such as some hubs.



## General CDP Operation

The switch stores information about adjacent CDP devices in a *CDP Neighbors table* maintained in the switch's MIB (Management Information Base). This data is available to SNMP-based applications designed to read CDP data from the MIB. For example:

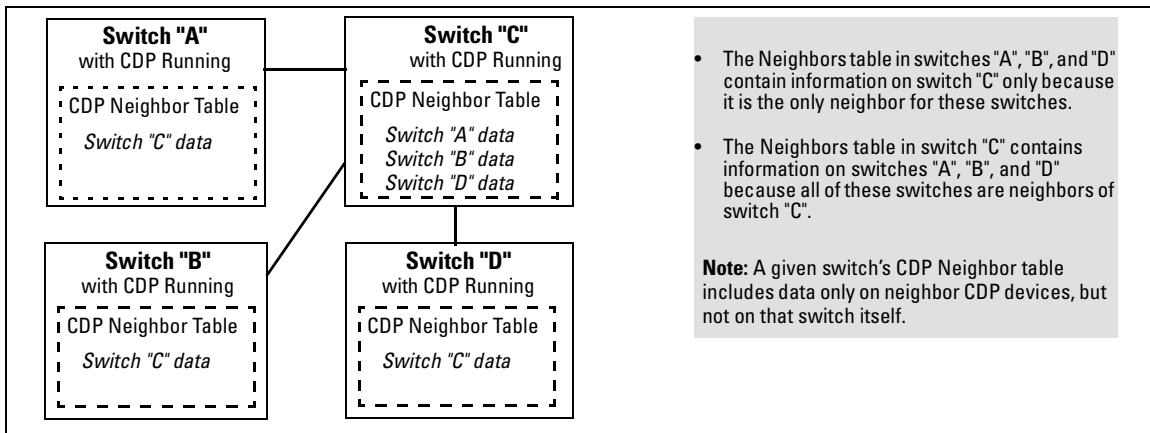

**Figure 10-5. Example of How the Switch Stores Data on Neighbor CDP Devices**

## Outgoing Packets

A Series 4100GL switch running CDP periodically transmits a one-hop CDP packet out each of its ports. This packet contains data describing the switch and, if the one-hop destination is another device running CDP, the receiving device stores the sending device's data in a CDP Neighbors table. The receiving device also transmits a similar one-hop CDP packet out each of its ports to make itself known to other CDP devices to which it is connected. Thus, each CDP device in the network provides data on itself to the CDP neighbors to which it is directly connected. However, there are instances where a packet is forwarded beyond the immediate neighbor, or simply dropped.

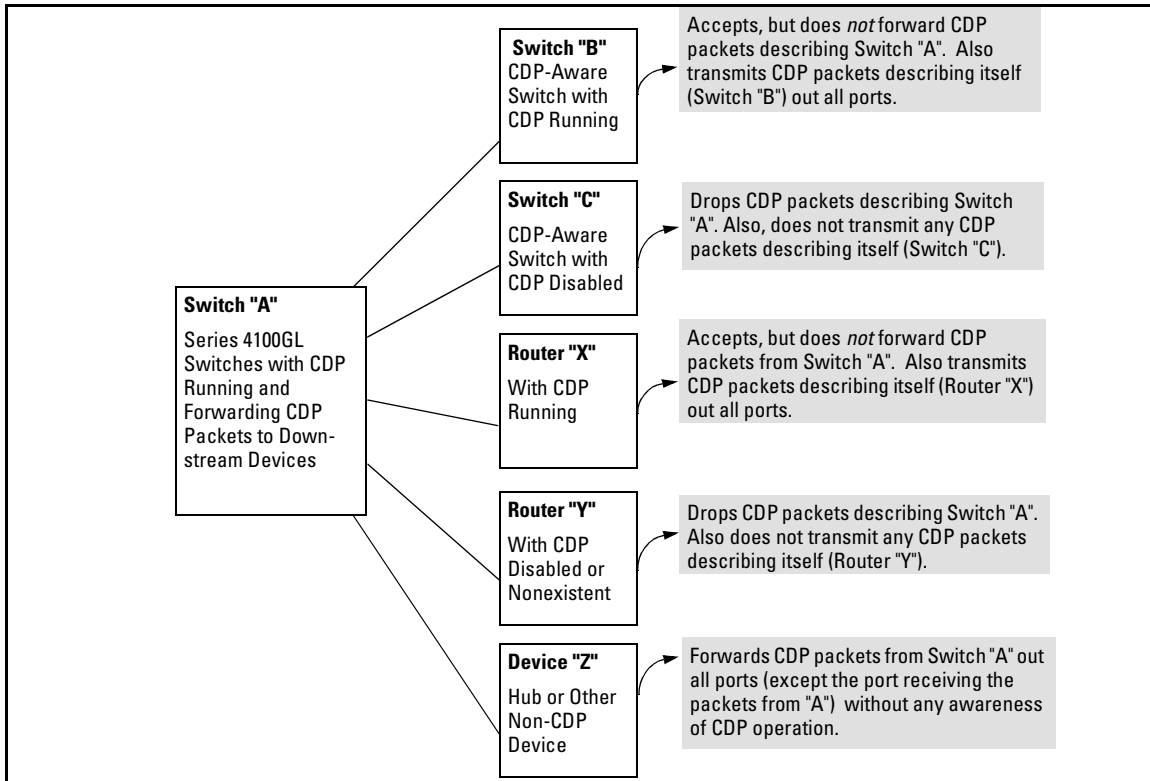

Figure 10-6. Example of Outgoing CDP Packet Operation

### Incoming CDP Packets

When a CDP-enabled Series 4100GL switches receives a CDP packet from another CDP device, it enters that device's data in the CDP Neighbors table, along with the port number where the data was received (and does not forward the packet). The switch also periodically purges the table of any entries that have expired. (The hold time for any data entry in the switch's CDP Neighbors table is configured in the device transmitting the CDP packet, and cannot be controlled in the switch receiving the packet.) A Series 4100GL switch reviews the list of CDP neighbor entries every three seconds, and purges any expired entries.

Non-CDP devices such as some hubs and other devices that do not have CDP capability are transparent to CDP operation. (Other hubs are CDP-aware, but still forward CDP packets as if they were transparent to CDP operation. See "CDP-Capable Hubs" on page 10-29.) However, an intervening CDP-aware device that is CDP-disabled is *not* transparent. For example, in figure 10-7, the

CDP neighbor pairs are as follows: A/1, A/2, A/3, A/B, B/C. Note that "C" and "E" are *not* neighbors because the intervening CDP-disabled switch "D" does not forward CDP packets; i.e. is not transparent to CDP traffic. (For the same reason, switch "E" does not have any CDP neighbors.)

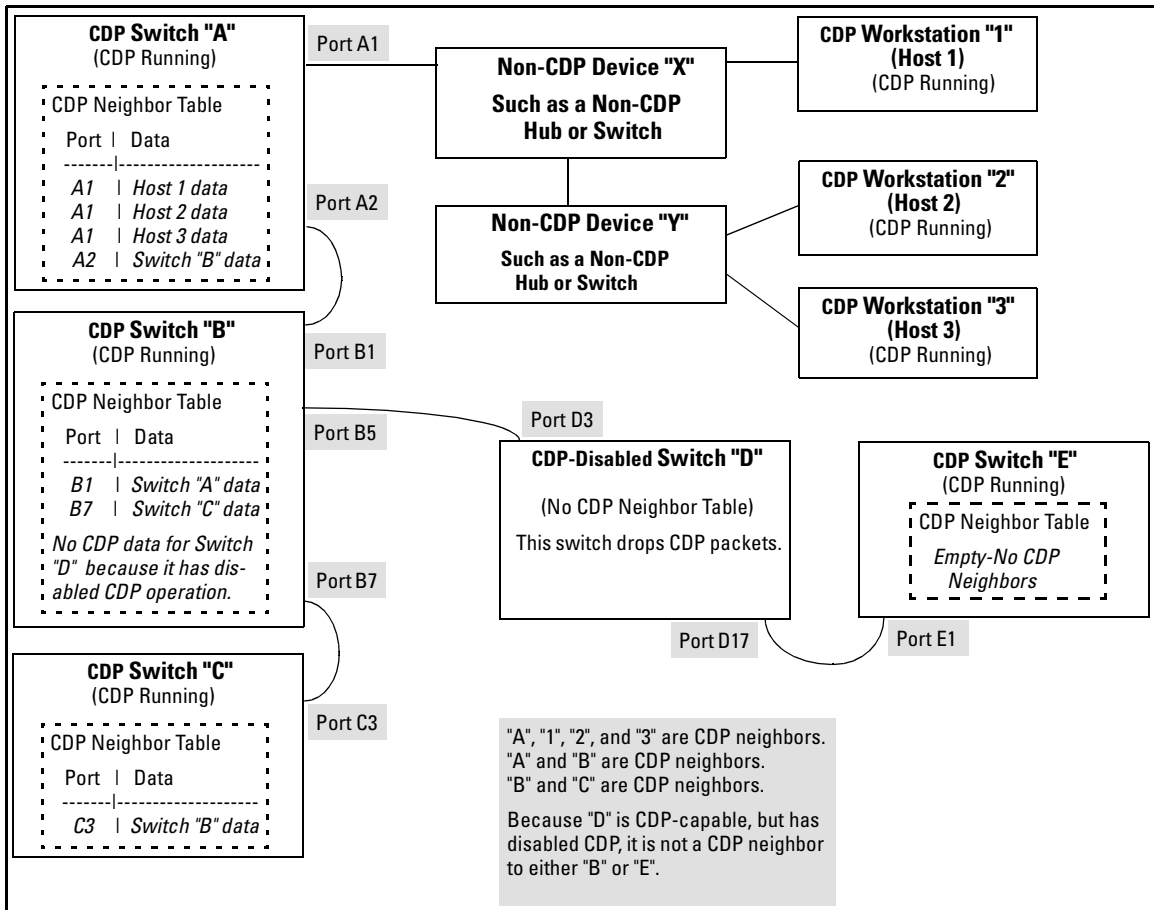

Figure 10-7. Example of Incoming CDP Packet Results

Using the example in figure 10-7, the CDP Neighbor table for switches "A" and "B" would appear similar to these:

**Switch A:**

Port	Device ID	Platform	Capability
A1	XYZ (0050c0-814b01)	XYZ Workstation	H
A1	XYZ (0050c0-850a43)	XYZ Workstation	H
A1	XYZ (0050c0-850b87)	XYZ Workstation	H
A2	HP4108 (0030c1-7fec40)	HP J4861A ProCurve Switch...	S

**Switch B:**

Port	Device ID	Platform	Capability
B1	Switch A (0030c1-583b39)	HP J4861A ProCurve Switch...	S
B7	Switch B (0060b0-889e00)	HP J4813A ProCurve Switch...	S

(Note that no CDP devices appear on port B5, which is connected to a device on which CDP is present, but disabled.)

**Figure 10-8. Example of Viewable CDP Neighbor Table for Switches "A" and "B" in Figure 10-2**

Thus, based on the CDP packets it receives, each CDP device maintains a per-port data entry for each of its neighbors that are running CDP, but not for other CDP devices that are accessible only through a CDP neighbor. (See the relationship between switches A, B, and C in figure 10-7.) In other words, a CDP device will have data on its immediate CDP neighbors (including those reached through a device that is transparent to CDP), but not to other CDP devices in the network.

**Table 10-1. How Devices Handle Incoming CDP Packets**

Status of Device Receiving a CDP Packet	Action of Receiving Device
Running CDP	Stores neighbor data in CDP Neighbor table. Does not forward CDP packet.
CDP Disabled	Drops CDP packet. There is no CDP Neighbor table and no CDP neighbor data is stored.
No CDP Capability	Forwards CDP packet out all ports except the port on which the packet was received.
Router Running CDP	Stores neighbor data in CDP Neighbor table. Does not forward CDP packet.
Router with CDP (1) Disabled or (2) Not CDP-Capable	Drops CDP packet.

Non-CDP devices (that is, devices that are not capable of running CDP) are transparent to CDP operation. However, an intervening CDP-aware device that is CDP-disabled is *not* transparent. For example, in figure 10-7 (page 10-17), "B", "D", and "E" are *not* CDP neighbors because "D" (the intervening

CDP-disabled switch) does not forward CDP packets; i.e. is not transparent to CDP traffic. (For the same reason, switch "E" does not have any CDP neighbors.)

Figure 10-7 (page 10-17) illustrates how multiple CDP neighbors can appear on a single port. In this case, switch "A" has three CDP neighbors on port 1 because the intervening devices are not CDP-capable and simply forward CDP neighbors data out all ports (except the port on which the data was received).

**Default Configuration.** In the factory-default configuration, CDP is enabled and running on all ports. In this case, the **holdtime** is 180 seconds and the **timer** (CDP Transmit Interval) is 60 seconds.

## Configuring CDP on the Switch

On a Series 4100GL switch you can:

- View the switch's current global and per-port CDP configuration
- List the current contents of the switch's CDP Neighbors table (that is, view a listing of the CDP devices of which the switch is aware)
- Enable or disable CDP (Default: Enabled)
- Specify the hold time (CDP packet time-to-live) for CDP data delivered to neighboring CDP devices. For example, in CDP switch "A" you can specify the hold time for switch "A" entries in the CDP Neighbor tables of other CDP devices. (Default: 180 seconds)
- Specify the transmission interval for CDP packets. (Default: 60 seconds)

### CLI: Viewing and Configuring CDP

CDP Commands	Page
show CDP	10-20
show CDP neighbors	10-20
cdp clear	10-21
[no] cdp run	10-22
[no] cdp enable	10-23
cdp holdtime	10-24
cdp timer	10-24

## Viewing the Switch's Current CDP Configuration

**Syntax:** show cdp

*Lists the switch's global and per-port CDP configuration.*

This example shows the default CDP configuration.

```
HPswitch(config)# show cdp
Global CDP information
  Enable CDP [Yes] : Yes
  CDP Hold Time [180] : 180
  CDP Transmit Interval [60] : 60
  Port CDP
  -----
  A1   enabled
  A2   enabled
  A3   enabled
  .
  .
  .
```

Port	CDP
A1	enabled
A2	enabled
A3	enabled
.	.
.	.
.	.

**Figure 10-9. Example of Show CDP with the Default CDP Configuration**

## Viewing the Switch's Current CDP Neighbors Table

Devices are listed by the port on which they were detected.

**Syntax:** show cdp neighbors

*Lists the neighboring CDP devices the switch detects, with a subset of the information collected from the device's CDP packet. (For more on this topic, refer to table 10-2, "CDP Neighbors Data" on page 10-27.)*

[ detail ]

*Provides a longer list of details on all of the CDP-aware device the switch detects.*

[ [e] port-num ]

*Lists the details for the CDP-aware device connected to the specified port. (Allows only one port at a time.)*

(For more on this topic, see "CDP Neighbor Data and MIB Objects" on page 10-26.)

Figure 10-10 lists six CDP devices (four switches and two workstations) that the switch has detected by receiving their CDP packets.

```

HPswitch> show cdp neighbors
CDP neighbors information

```

Port	Device ID	Platform	Capability
A1	Accounting(0030c1-7fcc40)	HP J4812A ProCurve Switch...	S
A2	Research(0060b0-889e43)	HP J4121A ProCurve Switch...	S
A4	Support(0060b0-761a45)	HP J4121A ProCurve Switch...	S
A7	Marketing(0030c5-38dc59)	HP J4813A ProCurve Switch...	S
A12	Mgmt NIC(099a05-09df9b)	NIC Model X666	H
A12	Mgmt NIC(099a05-09df11)	NIC Model X666	H

Figure 10-10. Example of CDP Neighbors Table Listing

Figure 10-11 illustrates a topology of CDP-enabled devices for the CDP Neighbors table listing in figure 10-10.

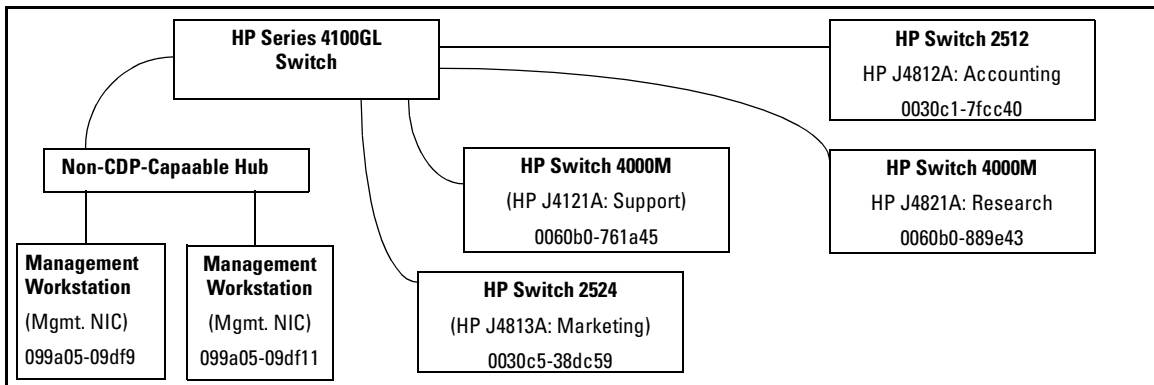

Figure 10-11. Example of CDP-Enabled Devices in a Topology for the Listing in Figure 10-10

## Clearing (Resetting) the CDP Neighbors Table

**Syntax:** `cdp clear`

*Removes any records of CDP neighbor devices from the switch's CDP MIB objects.*

If you execute **cdp clear** and then execute **show cdp neighbors** before the switch receives a CDP packet from any neighbor device, the displayed table appears empty.

```
HPswitch(config)# cdp clear
HPswitch(config)# show cdp neighbors

CDP neighbors information

Port Device ID | Platform | Capability
-----+-----

```

Note that the table will again list entries after the switch receives new CDP packets from neighboring CDP devices.

Figure 10-12. View of the CDP Neighbors Table Immediately After Executing cdp clear

### Configuring CDP Operation

**Enabling or Disabling CDP Operation on the Switch.** Enabling CDP operation (the default) on the switch causes the switch to:

- Transmit CDP packets describing itself to other, neighboring CDP devices
- Add entries to its CDP Neighbors table for any CDP packets it receives from other, neighboring CDP devices

Disabling CDP operation clears the switch's CDP Neighbors table, prevents the switch from transmitting outbound CDP packets to advertise itself to neighboring CDP devices, and causes the switch to drop inbound CDP packets from other devices without entering the data in the CDP Neighbors table.

**Syntax:** [no] cdp run

*Enables or disables CDP operation on the switch.  
(Default: Enabled)*

For example, to disable CDP on the switch:

```
HPswitch(config) no cdp run
```

When CDP is disabled:

- **show cdp neighbors** displays an empty CDP Neighbors table
- **show cdp** displays

```
Global CDP information
Enable CDP [Yes] : No
```



**Enabling or Disabling CDP Operation on Individual Ports.** In the factory-default configuration, the switch has all ports enabled and transmitting CDP packets. Disabling CDP on a port prevents that port from sending outbound CDP packets and causes it to drop inbound CDP packets without recording their data in the CDP Neighbors table. Suppose, for example, that switches "A" and "B" in figure 10-13 (below) are running CDP, and that port A1 on switch "A" is connected to port B5 on switch "B". If you disable CDP on port A1 of switch "A", then switch "B" will no longer receive CDP packets from switch "A" and switch "A" will drop the CDP packets it receives from switch "B".

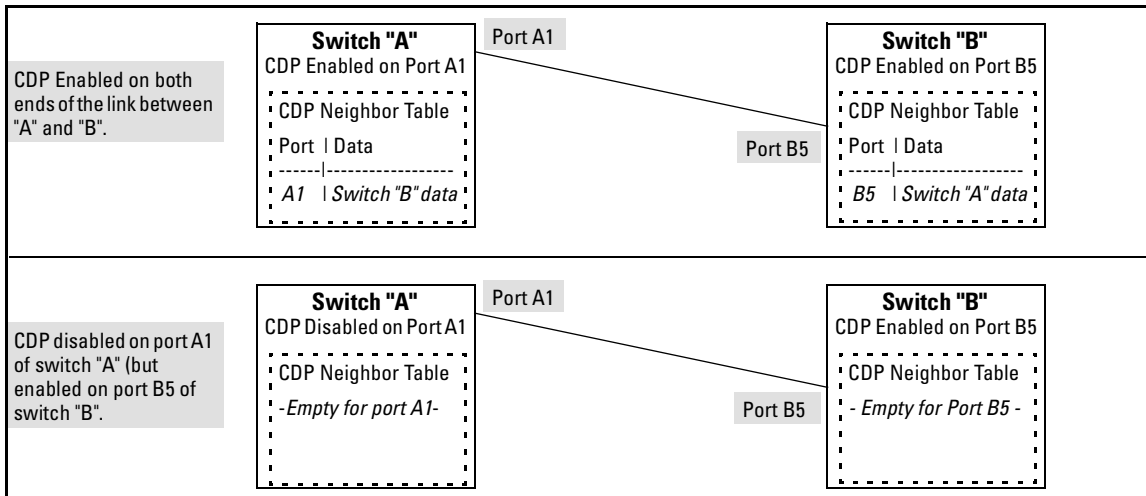

**Figure 10-13. Example of Disabling CDP on an Individual Port**

(The switch "A" entry in the switch "B" CDP Neighbors table remains until the **cdp holdtime** (time-to-live; set in switch "A") expires. Until then, the **show cdp neighbors** command continues to list switch "A" on port B5 of switch "B".)

**Syntax:** [no] cdp enable <[ethernet] port-list>

For example, to disable CDP on port A1 of a Series 4100GL switch:

```
HPswitch(config) no cdp enable a1
```

### Changing the Transmission Interval for Outbound CDP Packets.

**Syntax:** cdp timer < 5 .. 254 >

*Changes the interval the switch uses to transmit CDP packets describing itself to neighbor devices. (Default: 60 seconds)*

For example, if the switch's transmit interval for CDP packets was set to a non-default value, you would use this command to reset it to one minute:

```
HPswitch(config) cdp timer 60
```

**Changing the Hold Time (CDP Packet Time-To-Live) for a Switch's CDP Packet Information.** This parameter is controlled in the transmitting switch, and applies to all outbound CDP packets the switch transmits.

**Syntax:** cdp holdtime < 5 .. 254 >

*Changes the hold time for the switch's CDP packet information in the CDP Neighbors table of another CDP-aware device. (Default: 180 seconds; Range: 10 - 255 seconds.)*

For example, to configure a switch's outbound CDP packets to live for one minute in the CDP Neighbors table of neighboring CDP devices:

```
HPswitch(config) cdp holdtime 60
```

## Effect of Spanning Tree (STP) On CDP Packet Transmission

If STP has blocked a port on the switch, that port does not transmit CDP packets. However, the port still receives CDP packets if the device on the other end of the link has CDP enabled. Thus, for example, if switch "A" has two ports linked to switch "B" (which is a CDP neighbor and also the STP root device) and STP blocks traffic on one port and forwards traffic on the other:

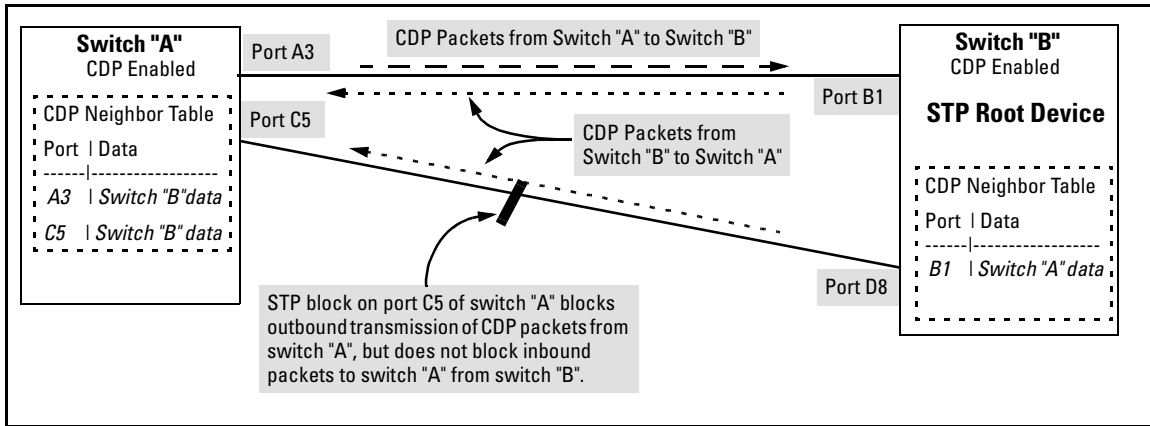

**Figure 10-14. Example of STP Effect on CDP Packet Transmission**

- Switch "A" sends outbound CDP packets on the forwarding link, and the switch "B" CDP Neighbors table shows switch "A" on only one port.
- Switch "B" sends outbound CDP packets on both links, and the switch "A" CDP Neighbors table shows switch "B" on both ports.

To summarize, in a CDP neighbor pair running STP with redundant links, if one of the switches is the STP root, it transmits CDP packets out all ports connecting the two switches, while the other switch transmits CDP packets out only the unblocked port. Thus, the STP root switch will appear on multiple ports in the non-root switch's CDP Neighbors table, while the non-root switch will appear on only one port in the root switch's CDP Neighbors table.

## How the Switch Selects the IP Address To Include in Outbound CDP Packets

A switch with CDP enabled uses the following prioritized criteria to determine which IP address to include in its outbound CDP packets:

1. If only one VLAN on the port has an IP address, the switch uses that IP address.
2. If the Primary VLAN on the port has an IP address, the switch uses the Primary VLAN IP address.
3. If 1 and 2 do not apply, then the switch determines which VLANs on the port have IP addresses and uses the IP address of the VLAN with the lowest VID (VLAN Identification number) in this group.

- If a CDP switch does not detect an IP address on the connecting port of a CDP neighbor, then the loopback IP address is used (127.0.0.1).

For example, in figure 10-15, port A1 on CDP switch "X" is connected to port C5 on CDP neighbor switch "Y", with the indicated VLAN configuration on port C5:

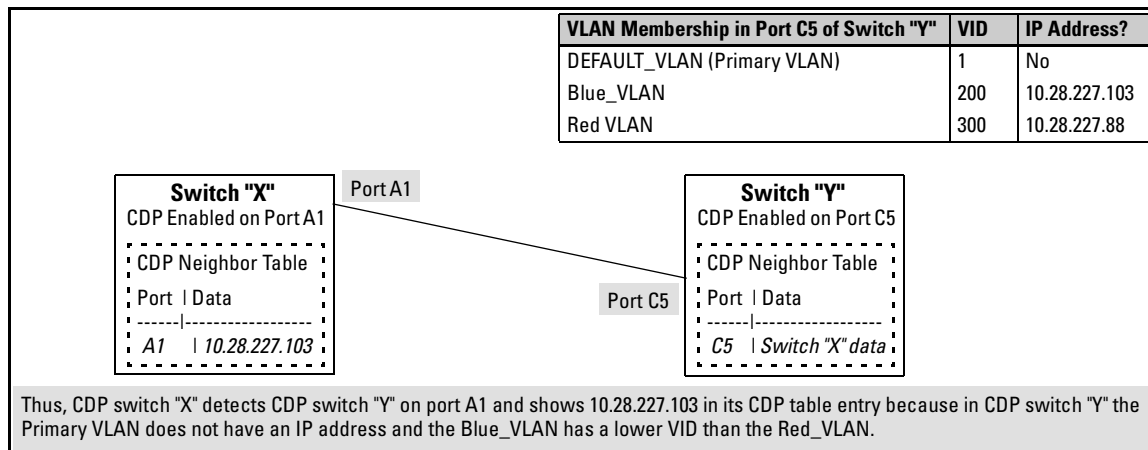

**Figure 10-15. Example of IP Address Selection when a CDP Neighbor Has Multiple VLANs with IP Addresses**

## CDP Neighbor Data and MIB Objects

The switch places the data received from inbound CDP packets into its MIB (Management Information Base). This data is available in three ways:

- Using the switch's **show cdp neighbors** command to display a subset of Neighbor data
- Using the **walkmib** command to display a listing of the CDP MIB objects
- Electronically, using an SNMP utility designed to search the MIB for CDP data

As shown under "Viewing the Switch's Current CDP Neighbors Table" on page 10-20, you can list a subset of data for each CDP device currently found in the switch's CDP Neighbors table. Table 10-2, "CDP Neighbors Data", describes the CDP Neighbor data set available in the Series 4100GL switches.

**Table 10-2. CDP Neighbors Data**

CDP Neighbor Data	Displayed Neighbors Table	MIB	
Address Type	No	Yes	Always "1" (IP address only).
CDP Cache Address	No	Yes	IP address of source device.
Software Version	Yes	Yes	ASCII String
Device Name (ASCII string)	Yes	Yes	In HP Procurve switches, this is the value configured for the System Name parameter.
Device MAC Address	Yes	Yes	Included in the Device Name entry.
Destination Port Number	Yes	Yes	On the Series 4100GL switches (the receiving device), the number of the port through which the CDP packet arrived.
Source Port Number	No	Yes	On the source (neighbor) device, the number of the port through which the CDP packet was sent.
Product Name (ASCII string)	Yes	Yes	Platform name designated by vendor.
Capability Code (Device Type)	Yes (alpha character)	Yes (numeric character)	1 or R: Router 2: Transparent Bridge 4 or B: Source Route Bridge 8 or S: Switch 16 or H: Host 32 or I: IGMP conditional filtering 64 or r: Repeater

**Displaying CDP Neighbor Data.**

**Syntax:** walkmib CdpCacheEntry

*Displays the superset of CDP neighbor held in the MIB.*

For example, with two CDP devices connected to ports A1 and A3 on the switch, you would see a **walkmib** listing similar to this:

CDP MIB data is grouped by type. That is, the Address Types for all detected CDP devices are listed first, then the IP addresses of the source devices, and so on.

```
HPswitch # walkmib CdpCacheEntry
cdpCacheAddressType.1.2 = 1
cdpCacheAddressType.3.1 = 1
cdpCacheAddress.1.2 = 42 3c a4 0b
cdpCacheAddress.3.1 = 7f 00 00 01
cdpCacheVersion.1.2 = Revision F.02.C1 /sw/code/build/info(f00)
cdpCacheVersion.3.1 = Revision C.09.02 /sw/code/build/vgro(c09)
cdpCacheDeviceId.1.2 = HP ProCurve Switch 2512 (005004-18df9c)
cdpCacheDeviceId.3.1 = HP4000 (0060b0-fc904b)
cdpCacheDevicePort.1.2 = 12
cdpCacheDevicePort.3.1 = A4
cdpCachePlatform.1.2 = HP J4812A ProCurve Switch 2512
cdpCachePlatform.3.1 = HP J4121A ProCurve Switch 4000M
cdpCacheCapabilities.1.2 = 8
cdpCacheCapabilities.3.1 = 8
```

The first number after the MIB string is the switch port on which the data point for that entry was received. In this case, the switch CDP packets on ports A1 and A3. (For CDP purposes, port numbering is consecutive, from 1 to *n*, where *n* is the last consecutive port on the switch.)

Figure 10-16. Example of CDP Neighbor Data in a Series 4100GL Switch MIB

For the current Series 4100GL switch MIB, go to the HP Procurve World Wide Web site at:

<http://www.hp.com/go/hpprocurve>

Click on **software**, then **MIBs**.

## Operating Notes

**Neighbor Maximum.** The Series 4100GL switches support up to 60 entries (neighbors) in the CDP Neighbors table. Remember that multiple CDP devices can be neighbors on the same port if they are connected to the switch through a non-CDP device.

**CDP Version Data.** The Series 4100GL switches use CDP-V1, but do not include IP prefix information, which is a router function; not a switch application.

**Port Trunking with CDP.** Where a static or LACP trunk forms the link between the switch and another CDP device, only one physical link in the trunk is used to transmit outbound CDP packets.

**CDP-Capable Hubs.** Some hubs are capable of running CDP, but also forward CDP packets as if the hub itself were transparent to CDP. Such hubs will appear in the switch's CDP Neighbor table and will also maintain a CDP neighbor table similar to that for switches. For more information, refer to the documentation provided for the specific hub.

**Troubleshooting CDP Operation.** Turn to “Using the Event Log To Identify Problem Sources” on page C-21.





# Port-Based Virtual LANs (VLANs) and GVRP

---

## Contents

<b>Overview</b> .....	11-2
<b>Port-Based Virtual LANs (Static VLANs)</b> .....	11-3
Overview of Using VLANs .....	11-6
VLAN Support and the Default VLAN .....	11-6
The Primary VLAN .....	11-6
Per-Port Static VLAN Configuration Options .....	11-7
General Steps for Using VLANs .....	11-9
Notes on Using VLANs .....	11-9
Menu: Configuring VLAN Parameters .....	11-10
CLI: Configuring VLAN Parameters .....	11-15
Web: Viewing and Configuring VLAN Parameters .....	11-21
VLAN Tagging Information .....	11-22
The Secure Management VLAN .....	11-26
Effect of VLANs on Other Switch Features .....	11-30
Spanning Tree Operation with VLANs .....	11-30
IP Interfaces .....	11-30
VLAN MAC Addresses .....	11-31
Port Trunks .....	11-31
Port Monitoring .....	11-31
VLAN Restrictions .....	11-31
<b>GVRP</b> .....	11-33
General Operation .....	11-34
Per-Port Options for Handling GVRP “Unknown VLANs” .....	11-36
Per-Port Options for Dynamic VLAN Advertising and Joining ....	11-38
GVRP and VLAN Access Control .....	11-40
Planning for GVRP Operation .....	11-41
Configuring GVRP On a Switch .....	11-41
GVRP Operating Notes .....	11-46

## Overview

This chapter describes the following features and how to configure them with the switch's built-in interfaces:

- **Port-Based VLANs — Page 11-3:**
- **GVRP — Page 11-33:**

For general information on how to use the switch's built-in interfaces, see:

- Chapter 2, "Using the Menu Interface"
- Chapter 3, "Using the Command Line Interface (CLI)"
- Chapter 4, "Using the HP Web Browser Interface"
- Chapter 5, "Switch Memory and Configuration"

---

## Port-Based Virtual LANs (Static VLANs)

### VLAN Features

Feature	Default	Menu	CLI	Web
view existing VLANs	n/a	page11-10 thru 11-15	page 11-16	page 11-21
configuring static VLANs	default VLAN with VID = 1	page11-10 thru 11-15	page 11-15	page 11-21
configuring dynamic VLANs	disabled	See "GVRP" on page 11-33.		

A VLAN is a group of ports designated by the switch as belonging to the same broadcast domain. (That is, all ports carrying traffic for a particular subnet address would normally belong to the same VLAN.)

---

### Note

This section describes *static* VLANs, which are VLANs you manually configure with a name, VLAN ID (VID), and port assignments. (For information on *dynamic* VLANs, see "GVRP" on page 11-33.)

Using a VLAN, you can group users by logical function instead of physical location. This helps to control bandwidth usage by allowing you to group high-bandwidth users on low-traffic segments and to organize users from different LAN segments according to their need for common resources.

By default, the Series 4100GL switches is 802.1Q VLAN enabled and allow up to 30 port-based VLANs (default: 8). For information on GVRP, see "GVRP" on page 11-33. (The 802.1Q compatibility enables you to assign each switch port to multiple VLANs, if needed, and the port-based nature of the configuration allows interoperation with older switches that require a separate port for each VLAN.)

**General Use and Operation.** Port-based VLANs are typically used to enable broadcast traffic reduction and to increase security. A group of network users assigned to a VLAN form a broadcast domain that is separate from other VLANs that may be configured on a switch. On a given switch, packets are forwarded only between ports that are designated for the same VLAN. Thus, all ports carrying traffic for a particular subnet address should be configured to the same VLAN. Cross-domain broadcast traffic in the switch is

eliminated and bandwidth is saved by not allowing packets to flood out all ports. An external router is required to enable separate VLANs on a switch to communicate with each other.

For example, referring to figure 11-1, if ports A1 through A4 belong to VLAN\_1 and ports A5 through A8 belong to VLAN\_2, traffic from end-node stations on ports A2 through A4 is restricted to only VLAN\_1, while traffic from ports A5 through A7 is restricted to only VLAN\_2. For nodes on VLAN\_1 to communicate with VLAN\_2, their traffic must go through an external router via ports A1 and A8.

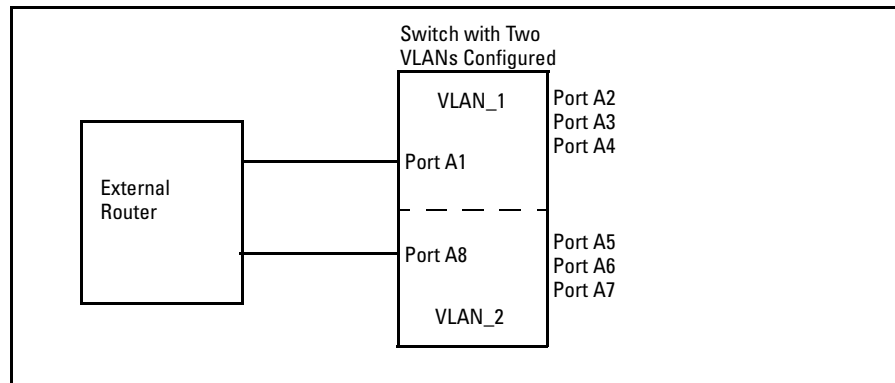

**Figure 11-1. Example of Routing Between VLANs via an External Router**

**Overlapping (Tagged) VLANs.** A port on the Series 4100GL switches can be a member of more than one VLAN if the device to which they are connected complies with the 802.1Q VLAN standard. For example, a port connected to a central server using a network interface card (NIC) that complies with the 802.1Q standard can be a member of multiple VLANs, allowing members of multiple VLANs to use the server. Although these VLANs cannot communicate with each other through the server, they can all access the server *over the same connection from the switch*. Where VLANs overlap in this way, VLAN “tags” are used to distinguish between traffic from different VLANs.

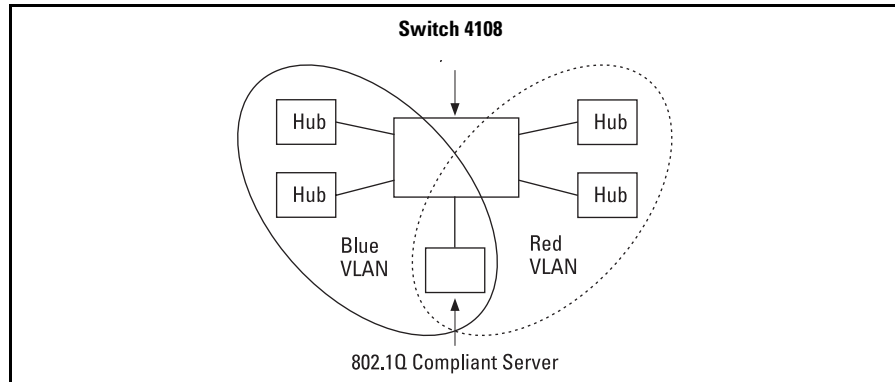

**Figure 11-2. Example of Overlapping VLANs Using the Same Server**

Similarly, using 802.1Q-compliant switches, you can connect multiple VLANs through a single switch-to-switch link.

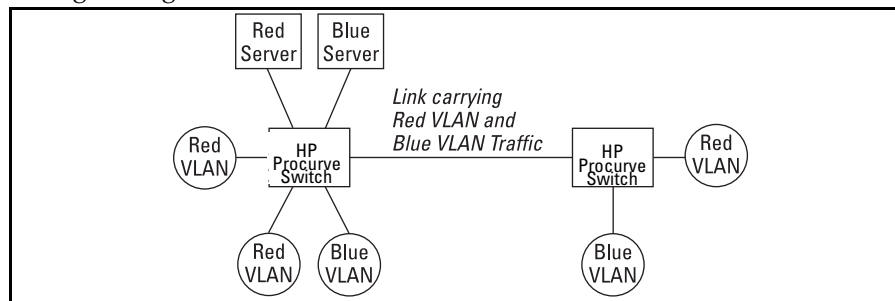

**Figure 11-3. Example of Connecting Multiple VLANs Through the Same Link**

**Introducing Tagged VLAN Technology into Networks Running Legacy (Untagged) VLANs.** You can introduce 802.1Q-compliant devices into networks that have built untagged VLANs based on earlier VLAN technology. The fundamental rule is that legacy/untagged VLANs require a separate link for each VLAN, while 802.1Q, or tagged VLANs can combine several VLANs in one link. This means that on the 802.1Q-compliant device, separate ports (configured as untagged) must be used to connect separate VLANs to non-802.1Q devices.

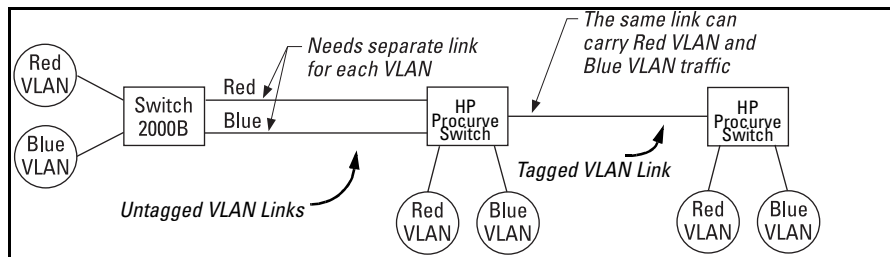

**Figure 11-4. Example of Tagged and Untagged VLAN Technology in the Same Network**

For more information on VLANs, refer to:

- “Overview of Using VLANs” (page 11-6)
- “Menu: Configuring VLAN Parameters (page 11-10)
- “CLI: Configuring VLAN Parameters” (page 11-10)
- “Web: Viewing and Configuring VLAN Parameters” (page 11-21)
- “VLAN Tagging Information” (page 11-22)
- “Effect of VLANs on Other Switch Features” (page 11-30)
- “VLAN Restrictions” (page 11-31)

## Overview of Using VLANs

### VLAN Support and the Default VLAN

In the factory default configuration, VLAN support is enabled and all ports on the switch belong to the default VLAN (named DEFAULT\_VLAN). This places all ports in the switch into one physical broadcast domain. In the factory-default state, the default VLAN is the primary VLAN.

You can partition the switch into multiple virtual broadcast domains by adding one or more additional VLANs and moving ports from the default VLAN to the new VLANs. (The switch supports up to 30 VLANs.) You can change the name of the default VLAN, but you cannot change the default VLAN’s VID (which is always “1”). Although you can remove all ports from the default VLAN, this VLAN is always present; that is, you cannot delete it from the switch.

### The Primary VLAN

Because certain features and management functions, such as single IP-address stacking, run on only one VLAN in the switch, and because DHCP and Bootp can run per-VLAN, there is a need for a dedicated VLAN to manage these

features and ensure that multiple instances of DHCP or Bootp on different VLANs do not result in conflicting configuration values for the switch. The *primary* VLAN is the VLAN the switch uses to run and manage these features and data. In the factory-default configuration, the switch designates the default VLAN (DEFAULT\_VLAN) as the primary VLAN. However, to provide more control in your network, you can designate another VLAN as primary. To summarize, *designating a non-default VLAN as primary* means that:

- The stacking feature runs on the switch's designated primary VLAN instead of the default VLAN
- The switch reads DHCP responses on the primary VLAN instead of on the default VLAN. (This includes such DHCP-resolved parameters as the TimeP server address, Default TTL, and IP addressing—including the Gateway IP address—when the switch configuration specifies DHCP as the source for these values.)
- The default VLAN continues to operate as a standard VLAN (except, as noted above, you cannot delete it or change its VID).
- Any ports not specifically assigned to another VLAN will remain assigned to the Default VLAN, regardless of whether it is the primary VLAN.

Candidates for primary VLAN include any static VLAN currently configured on the switch. (A dynamic—GVRP-learned—VLAN that has not been converted to a static VLAN cannot be the primary VLAN.) To display the current primary VLAN, use the CLI **show vlan** command.

---

**Note**

If you configure a non-default VLAN as the primary VLAN, you cannot delete that VLAN unless you first select a different VLAN to act as primary.

If you manually configure a gateway on the switch, it will ignore any gateway address received via DHCP or Bootp.

---

## Per-Port Static VLAN Configuration Options

The following figure and table show the options you have for assigning individual ports to a static VLAN. Note that GVRP, if configured, affects these options and VLAN behaviour on the switch. The display below shows the per-port VLAN configuration options. Table 11-11-1 briefly describes these options.

**Example of Per-Port  
VLAN Configuration  
with GVRP Disabled  
(the default)**

Port	DEFAULT_VLAN	VLAN-22
A1	Untagged	Forbid
A2	No	Tagged
A3	No	Tagged
A4	Forbid	Tagged
A5	Untagged	No

**Example of Per-Port  
VLAN Configuration  
with GVRP Enabled**

Port	DEFAULT_VLAN	VLAN-22
A1	Untagged	Forbid
A2	Auto	Tagged
A3	Auto	Tagged
A4	Forbid	Tagged
A5	Untagged	Auto

Enabling GVRP causes "No" to display as "Auto".

**Figure 11-5. Comparing Per-Port VLAN Options With and Without GVRP**

**Table 11-1. Per-Port VLAN Configuration Options**

Parameter	Effect on Port Participation in Designated VLAN
<b>Tagged</b>	Allows the port to join multiple VLANs.
<b>Untagged</b>	Allows VLAN connection to a device that is configured for an untagged VLAN instead of a tagged VLAN. The switch allows no more than one untagged VLAN assignment per port.
<b>No</b> - or - <b>Auto</b>	<b>No:</b> Appears when the switch is not GVRP-enabled; prevents the port from joining that VLAN. <b>Auto:</b> Appears when GVRP is enabled on the switch; allows the port to dynamically join any advertised VLAN that has the same VID
<b>Forbid</b>	Prevents the port from joining the VLAN, regardless of whether GVRP is enabled on the switch.



## General Steps for Using VLANs

1. Plan your VLAN strategy and create a map of the logical topology that will result from configuring VLANs. Include consideration for the interaction between VLANs and other features such as Spanning Tree Protocol, load balancing, and IGMP. (Refer to “Effect of VLANs on Other Switch Features” on page 11-30.) If you plan on using dynamic VLANs, include the port configuration planning necessary to support this feature. (See “GVRP” on page 11-33.)

By default, VLAN support is enabled and the switch is configured for eight VLANs.

2. Configure at least one VLAN in addition to the default VLAN.
3. Assign the desired switch ports to the new VLAN(s).
4. If you are managing VLANs with SNMP in an IP network, each VLAN must have an IP address. Refer to “IP Configuration” on page 7-3.

## Notes on Using VLANs

- If you are using DHCP/Bootp to acquire the switch’s configuration, packet time-to-live, and TimeP information, you must designate the VLAN on which DHCP is configured for this purpose as the primary VLAN. (In the factory-default configuration, the DEFAULT\_VLAN is the primary VLAN.)
- IGMP, and some other features operate on a “per VLAN” basis. This means you must configure such features separately for each VLAN in which you want them to operate.
- You can rename the default VLAN, but you cannot change its VID (1) or delete it from the switch.
- Any ports *not* specifically assigned to another VLAN will remain assigned to the DEFAULT\_VLAN.
- To delete a VLAN from the switch, you must first remove from that VLAN any ports assigned to it.
- Changing the number of VLANs supported on the switch requires a reboot. Other VLAN configuration changes are dynamic.

## Menu: Configuring VLAN Parameters

In the factory default state, support is enabled for up to eight VLANs. (You can change the switch VLAN configuration to support up to 30 VLANs.) Also, all ports on the switch belong to the default VLAN (DEFAULT\_VLAN) and are in the same broadcast/multicast domain. (The default VLAN is also the default primary VLAN—see “The Primary VLAN” on page 11-6.) In addition to the default VLAN, you can configure up to 29 other static VLANs by changing the “Maximum VLANs” parameter, adding new VLAN names and VIDs, and then assigning one or more ports to each VLAN. (The switch accepts a maximum of 30 VLANs, including the default VLAN and any dynamic VLANs the switch creates if you enable GVRP—page 11-33.) Note that each port can be assigned to multiple VLANs by using VLAN tagging. (See “VLAN Tagging Information” on page 11-22.)

### To Change VLAN Support Settings

This section describes:

- Changing the maximum number of VLANs to support
  - Changing the primary VLAN selection (See “Changing the Primary VLAN” on page 11-18.)
  - Enabling or disabling dynamic VLANs (See “GVRP” on page 11-33.)
1. From the Main Menu select:

#### 2. Switch Configuration

#### 8. VLAN Menu . . .

#### 1. VLAN Support

You will then see the following screen:

```
----- CONSOLE - MANAGER MODE -----
                Switch Configuration - VLAN - VLAN Support

Maximum VLANs to support [8] : 8
Primary VLAN : DEFAULT_VLAN
GVRP Enabled [No] : No

Actions->  Cancel  Edit  Save  Help
Cancel changes and return to previous screen.
Use arrow keys to change action selection and <Enter> to execute action.
```

**Figure 11-6. The Default VLAN Support Screen**

2. Press **[E]** (for **E**dit), then do one or more of the following:

- To change the maximum number of VLANs, type the new number (1 - 30 allowed; default 8).
- To designate a different VLAN as the primary VLAN, select the **Primary VLAN** field and use the space bar to select from the existing options.
- To enable or disable dynamic VLANs, select the **GVRP Enabled** field and use the Space bar to toggle between options. (For GVRP information, see “GVRP” on page 11-33.)

---

**Note**

For optimal switch memory utilization, set the number of VLANs at the number you will likely be using or a few more. If you need more VLANs later, you can increase this number, but a switch reboot will be required at that time.

3. Press **[Enter]** and then **[S]** to save the VLAN support configuration and return to the VLAN Menu screen.

If you changed the value for **Maximum VLANs to support**, you will see an asterisk next to the **VLAN Support** option (see below).

An asterisk indicates you must reboot the switch to implement the new Maximum VLANs setting.

```
----- CONSOLE - MANAGER MODE -----  
Switch Configuration - VLAN Menu  
  
*1. VLAN Support  
2. VLAN Names  
3. VLAN Port Assignment  
4. Return to Previous Menu...  
0. Return to Main Menu...  
  
Displays the menu to activate and configure, or deactivate VLAN support.  
To select menu item, press item number, or highlight item and press <Enter>.  
(*Needs reboot to activate changes.)
```

**Figure 11-7. VLAN Menu Screen Indicating the Need To Reboot the Switch**

- If you changed the VLAN Support option, you must reboot the switch before the Maximum VLANs change can take effect. You can go on to configure other VLAN parameters first, but remember to reboot the switch when you are finished.
- If you did not change the VLAN Support option, a reboot is not necessary.

4. Press **[0]** to return to the Main Menu.

## Adding or Editing VLAN Names

Use this procedure to add a new VLAN or to edit the name of an existing VLAN.

1. From the Main Menu select:
  2. **Switch Configuration**
  8. **VLAN Menu . . .**
  2. **VLAN Names**

If multiple VLANs are not yet configured you will see a screen similar to figure 11-8:

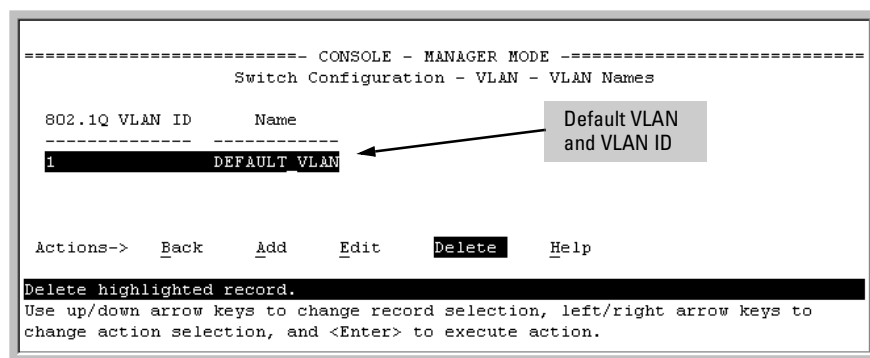

**Figure 11-8. The Default VLAN Names Screen**

2. Press **[A]** (for **Add**). You will then be prompted for a new VLAN name and VLAN ID:

```
802.1Q VLAN ID : 1
Name : _
```

3. Type in a VID (VLAN ID number). This can be any number from 2 to 4094 that is not already being used by another VLAN. (The switch reserves “1” for the default VLAN.)

Remember that a VLAN *must* have the same VID in every switch in which you configure that same VLAN. (GVRP dynamically extends VLANs with correct VID numbering to other switches. See “GVRP” on page 11-33.)

4. Press **[↓]** to move the cursor to the **Name** line and type the VLAN name (up to 12 characters, with no spaces) of a new VLAN that you want to add, then press **[Enter]**.  
(Avoid these characters in VLAN names: **2, #, \$, ^, &, \*, (, and ).**)
5. Press **[S]** (for **Save**). You will then see the VLAN Names screen with the new VLAN listed.

```
----- CONSOLE - MANAGER MODE -----  
Switch Configuration - VLAN - VLAN Names  
  
802.1Q VLAN ID      Name  
-----  
1                   DEFAULT VLAN  
22                  VLAN-22  
  
Actions->  Back    Add    Edit    Delete    Help  
  
Add a new record.  
Use up/down arrow keys to change record selection, left/right arrow keys to  
change action selection, and <Enter> to execute action.
```

**Figure 11-9. Example of VLAN Names Screen with a New VLAN Added**

6. Repeat steps 2 through 5 to add more VLANs.  
Remember that you can add VLANs until you reach the number specified in the **Maximum VLANs to support** field on the VLAN Support screen (see figure 11-6 on page 11-10). This includes any VLANs added dynamically due to GVRP operation.
7. Return to the VLAN Menu to assign ports to the new VLAN(s) as described in the next section, “Adding or Changing a VLAN Port Assignment”.

### Adding or Changing a VLAN Port Assignment

Use this procedure to add ports to a VLAN or to change the VLAN assignment(s) for any port. (Ports not specifically assigned to a VLAN are automatically in the default VLAN.)

1. From the Main Menu select:
  2. **Switch Configuration**
  8. **VLAN Menu . . .**
  3. **VLAN Port Assignment**

You will then see a VLAN Port Assignment screen similar to the following:

## Port-Based Virtual LANs (VLANs) and GVRP

### Port-Based Virtual LANs (Static VLANs)

**Default:** In this example, the “VLAN-22” has been defined, but no ports have yet been assigned to it. (“No” means the port is not assigned to that VLAN.)

**Using GVRP?** If you plan on using GVRP, any ports you don’t want to join should be changed to “Forbid”.

A port can be assigned to several VLANs, but only one of those assignments can be “Untagged”.

```
===== CONSOLE - MANAGER MODE =====
Switch Configuration - VLAN - VLAN Port Assignment

Port  DEFAULT_VLAN  VLAN-22  |  Port  DEFAULT_VLAN  VLAN-22
-----+-----+-----+-----+-----+-----+
A1   | Untagged   No       |  A8   | Untagged   No
A2   | Tagged     No       |  A9   | Untagged   No
A3   | Untagged   No       |  A10  | Untagged   No
A4   | Untagged   No       |  A11  | Untagged   No
A5   | Untagged   No       |  A12  | Untagged   No
A6   | Untagged   No       |  A13  | Untagged   No
A7   | Untagged   No       |  A14  | Untagged   No

Actions->  Cancel  Edit  Save  Help

Cancel changes and return to previous screen.
Use arrow keys to change action selection and <Enter> to execute action.
```

**Figure 11-10. Example of VLAN Port Assignment Screen**

2. To change a port’s VLAN assignment(s):
  - a. Press **[E]** (for **Edit**).
  - b. Use the arrow keys to select a VLAN assignment you want to change.
  - c. Press the Space bar to make your assignment selection (**No**, **Tagged**, **Untagged**, or **Forbid**).

---

### Note

**For GVRP Operation:** If you enable GVRP on the switch, “No” converts to “Auto”, which allows the VLAN to dynamically join an advertised VLAN that has the same VID. See “Per-Port Options for Dynamic VLAN Advertising and Joining” on page 11-38.

**Untagged VLANs:** Only one untagged VLAN is allowed per port. Also, there must be at least one VLAN assigned to each port. In the factory default configuration, all ports are assigned to the default VLAN (DEFAULT\_VLAN).

For example, if you want ports A4 and A5 to belong to both DEFAULT\_VLAN and VLAN-22, and ports A6 and A7 to belong only to VLAN-22, you would use the settings in figure page 11-15. (This example assumes the default GVRP setting—disabled—and that you do not plan to enable GVRP later.)

Ports A4 and A5 are assigned to both VLANs.

Ports A6 and A7 are assigned only to VLAN-22.

All other ports are assigned only to the Default VLAN.

```

----- CONSOLE - MANAGER MODE -----
                Switch Configuration - VLAN - VLAN Port Assignment

  Port  DEFAULT_VLAN  VLAN-22  |  Port  DEFAULT_VLAN  VLAN-22
-----+-----+-----+-----+-----+-----+
  A1   | Untagged   No      |  A8   | Untagged   No
  A2   | Untagged   No      |  A9   | Untagged   No
  A3   | Untagged   No      |  A10  | Untagged   No
  A4   | Untagged   Tagged  |  A11  | Untagged   No
  A5   | Untagged   Tagged  |  A12  | Untagged   No
  A6   | No         Untagged |  A13  | Untagged   No
  A7   | No         Untagged |  A14  | Untagged   No

  Actions->  C   a   n   c   e   l       E   d   i   t       S   a   v   e       H   e   l   p

Select the tagging mode for the port/VLAN combination.
Use arrow keys to change field selection, <Space> to toggle field choices,
and <Enter> to go to Actions.
  
```

**Figure 11-11. Example of VLAN Assignments for Specific Ports**

For information on VLAN tags (“Untagged” and “Tagged”), refer to “VLAN Tagging Information” on page 11-22.

- d. If you are finished assigning ports to VLANs, press **[Enter]** and then **[S]** (for **Save**) to activate the changes you’ve made and to return to the Configuration menu. (The console then returns to the VLAN menu.)
3. Return to the Main menu.

## CLI: Configuring VLAN Parameters

In the factory default state, all ports on the switch belong to the default VLAN (DEFAULT\_VLAN) and are in the same broadcast/multicast domain. (The default VLAN is also the default primary VLAN—see “The Primary VLAN” on page 11-6.) You can configure up to 29 additional static VLANs by adding new VLAN names, and then assigning one or more ports to each VLAN. (The switch accepts a maximum of 30 VLANs, including the default VLAN and any dynamic VLANs the switch creates if you enable GVRP—page 11-33.) Note that each port can be assigned to multiple VLANs by using VLAN tagging. (See “VLAN Tagging Information” on page 11-22.)

### VLAN Commands Used in this Section

---

show vlans	below
show vlan <vlan-id>	page 11-17
max-vlans <1..30>	page 11-18
primary-vlan <vlan-id>	page 11-18
[no] vlan <vlan-id>	page 11-19
name <vlan-name>	page 11-20
[no] tagged <port-list>	page 11-20
[no] untagged <port-list>	page 11-20
[no] forbid	page 11-20
auto <port-list>	page 11-20 (Available if GVRP enabled.)
static-vlan <vlan-id>	page 11-20 (Available if GVRP enabled.)

---

**Displaying the Switch's VLAN Configuration.** The next command lists the VLANs currently running in the switch, with VID, VLAN name, and VLAN status. Dynamic VLANs appear only if the switch is running with GVRP enabled and one or more ports has dynamically joined an advertised VLAN. (In the default configuration, GVRP is disabled. (See "GVRP" on page 11-33.)

**Syntax:** show vlan

```
HPswitch(config)# show vlan
Status and Counters - VLAN Information
VLAN support : Yes
Maximum VLANs to support : 8
Primary VLAN : DEFAULT_VLAN

802.1Q VLAN ID Name          Status
-----
1          DEFAULT_VLAN  Static
22         VLAN-22     Static
33         GVRP_33     Dynamic
```

**Figure 11-12. Example of "Show VLAN" Listing (GVRP Enabled)**



**Displaying the Configuration for a Particular VLAN .** This command uses the VID to identify and display the data for a specific static or dynamic VLAN.

**Syntax:** show vlan <vlan-id>

```
HPswitch> show vlan 22
Status and Counters - VLAN Information - Ports - VLAN 22

802.1Q VLAN ID : 22
Name           : VLAN-22
Status         : Static

Port Information Mode      Unknown VLAN Status
-----
A1              Tagged   Learn      Up
A2              Tagged   Learn      Up
A5              Untagged Learn      Up
A6              Untagged Learn      Up
A7              Untagged Learn      Up
```

**Figure 11-13. Example of “Show VLAN” for a Specific Static VLAN**

<p><b>Show VLAN</b> lists this data when GVRP is enabled and at least one port on the switch has dynamically joined the designated VLAN.</p>	<pre>HPswitch&gt; show vlan 44 Status and Counters - VLAN Information - Ports - VLAN 44  802.1Q VLAN ID : 44 Name           : GVRP_44 Status         : Dynamic  Port Information Mode      Unknown VLAN Status ----- A6              Auto     Learn      Up</pre>
--	---

**Figure 11-14. Example of “Show VLAN” for a Specific Dynamic VLAN**

**Changing the Number of VLANs Allowed on the Switch.** By default, the switch allows a maximum of 8 VLANs. You can specify any value from 1 to 30. (If GVRP is enabled, this setting includes any dynamic VLANs on the switch.) As part of implementing a new value, you must execute a write memory command (to save the new value to the startup-config file) and then reboot the switch.

**Syntax:** max-vlans <1 .. 30>

For example, to reconfigure the switch to allow 10 VLANs:

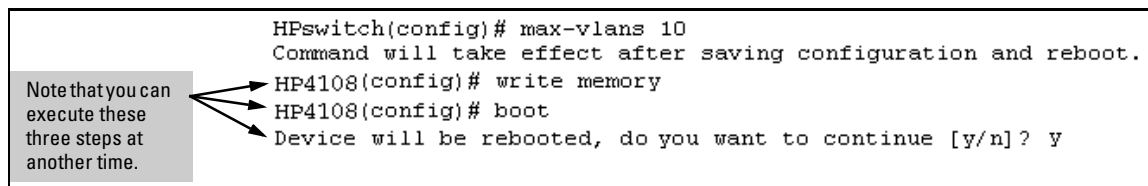

```
HPswitch(config)# max-vlans 10
Command will take effect after saving configuration and reboot.
HP4108(config)# write memory
HP4108(config)# boot
Device will be rebooted, do you want to continue [y/n]? y
```

Note that you can execute these three steps at another time.

**Figure 11-15. Example of Command Sequence for Changing the Number of VLANs**

**Changing the Primary VLAN.** In the factory-default configuration, the default VLAN (DEFAULT\_VLAN) is the primary VLAN. However, you can designate any static VLAN on the switch as the primary VLAN. (For more on the primary VLAN, see “The Primary VLAN” on page 11-6.) To view the available VLANs and their respective VIDs, use **show vlan**.

**Syntax:** primary-vlan <vlan-id>

For example, to make VLAN 22 the primary VLAN:

```
HPswitch(config)# primary-vlan 22
```

## Creating a New Static VLAN Changing the VLAN Context Level.

With this command, entering a new VID creates a new static VLAN. Entering the VID or name of an existing static VLAN places you in the context level for that VLAN.

**Syntax:** `vlan <vlan-id> [name <name-str>]` Creates a new static VLAN if a VLAN with that VID does not already exist, and places you in that VLAN's context level. If you do not use the name option, the switch uses "VLAN" and the new VID to automatically name the VLAN.  
If the VLAN already exists, the switch places you in the context level for that VLAN.

`vlan <vlan-name>`

Places you in the context level for that static VLAN.

For example, to create a new static VLAN with a VID of 100:

```
HPswitch(config)# vlan 100
100: VLAN added.
HP4108(vlan-100)# show vlan

Status and Counters - VLAN Information

VLAN support : Yes
Maximum VLANs to support : 10
Primary VLAN : DEFAULT_VLAN

802.1Q VLAN ID Name          Status
-----
1          DEFAULT_VLAN  Static
100       VLAN100      Static
```

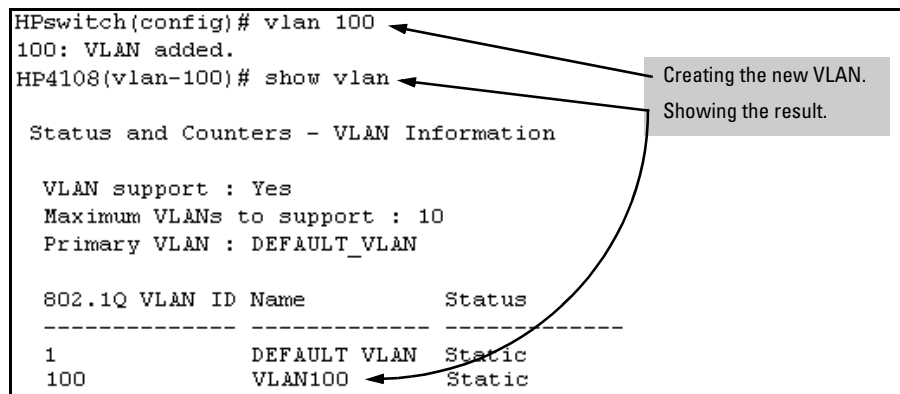

**Figure 11-16. Example of Creating a New Static VLAN**

To go to a different VLAN context level, such as to the default VLAN:

```
HPswitch(vlan-100)# vlan default_vlan
HPswitch(vlan-1) _
```

**Converting a Dynamic VLAN to a Static VLAN.** If GVRP is running on the switch and a port dynamically joins a VLAN, you can use the next command to convert the dynamic VLAN to a static VLAN. (For GVRP and dynamic VLAN operation, see “GVRP” on page 11-33.) This is necessary if you want to make the VLAN permanent. After you convert a dynamic VLAN to static, you must configure the switch’s per-port participation in the VLAN in the same way that you would for any static VLAN.

**Syntax:** static-vlan <vlan-id> (Use **show vlan** to list current VLANs.)

For example, suppose a dynamic VLAN with a VID of 125 exists on the switch. The following command converts the VLAN to a static VLAN.

```
HPswitch(config)# static-vlan 125
```

**Configuring Static VLAN Name and Per-Port Settings.** The **vlan <vlan-id>** command, used with the options listed below, changes the name of an existing static VLAN and changes the per-port VLAN membership settings.

---

**Note**

---

You can use these options from the configuration level by beginning the command with **vlan <vlan-id>**, or from the context level of the specific VLAN.

<b>Syntax:</b> name <vlan-name>	Changes the name of the existing static VLAN. (Avoid spaces and the following characters in the <vlan-name> entry: <b>2, #, \$, ^, &amp;, *, (, and )</b> .)
[no] tagged <port-list>	Configures the indicated port(s) as <b>Tagged</b> for the specified VLAN. The “no” version sets the port(s) to either <b>No</b> or (if GVRP is enabled) to <b>Auto</b> .
[no] untagged <port-list>	Configures the indicated port(s) as <b>Untagged</b> for the specified VLAN. The “no” version sets the port(s) to either <b>No</b> or (if GVRP is enabled) to <b>Auto</b> .
[no] forbid <port-list>	Configures the indicated port(s) as “forbidden” to participate in the designated VLAN. The “no” version sets the port(s) to either <b>No</b> or (if GVRP is enabled) to <b>Auto</b> .
auto <port-list>	Available if GVRP is enabled on the switch. Returns the per-port settings for the specified VLAN to <b>Auto</b> operation. Note that <b>Auto</b> is the default per-port setting for a static VLAN if GVRP is running on the switch.

(For information on dynamic VLAN and GVRP operation, see “GVRP” on page 11-33.)

For example, if you have a VLAN named VLAN100 with a VID of 100, and all ports are set to **No** for this VLAN. To change the VLAN name to “Blue\_Team” and set ports 1-5 to Tagged, you could do so with these commands:

```
HPswitch(config)# vlan 100 name Blue_Team  
HPswitch(config)# vlan 100 tagged 1-5
```

To move to the vlan 100 context level and execute the same commands:

```
HPswitch(config)# vlan 100  
HPswitch(vlan-100)# name Blue_Team  
HPswitch(vlan-100)# tagged 1-5
```

Similarly, to change the tagged ports in the above examples to **No** (or **Auto**, if GVRP is enabled), you could use either of the following commands.

At the config level, use:

```
HPswitch(config)# no vlan 100 tagged 1-5  
- or -
```

At the VLAN 100 context level, use:

```
HPswitch(vlan-100)# no tagged 1-5
```

---

## Note

You cannot use these commands with dynamic VLANs. Attempting to do so results in the message “**VLAN already exists.**” and no change occurs.

## Web: Viewing and Configuring VLAN Parameters

In the web browser interface you can do the following:

- Add VLANs
- Rename VLANs
- Remove VLANs
- Configure GVRP mode
- Select a new Primary VLAN

To configure static VLAN port parameters, you will need to use the menu interface (available by Telnet from the web browser interface) or the CLI.

1. Click on the Configuration tab.
2. Click on [VLAN Configuration](#).
3. Click on [Add/Remove VLANs](#).

For web-based Help on how to use the web browser interface screen, click on the [?](#) button provided on the web browser screen.

## VLAN Tagging Information

VLAN tagging enables traffic from more than one VLAN to use the same port. (Even when two or more VLANs use the same port they remain as separate domains and cannot receive traffic from each other without going through an external router.) As mentioned earlier, a “tag” is simply a unique VLAN identification number (VLAN ID, or VID) assigned to a VLAN at the time that you configure the VLAN name in the switch. In the Series 4100GL switches the tag can be any number from 1 to 4094 that is not already assigned to a VLAN. When you subsequently assign a port to a given VLAN, you must implement the VLAN tag (VID) if the port will carry traffic for more than one VLAN. Otherwise, the port VLAN assignment can remain “untagged” because the tag is not needed. On a given switch, this means you should use the “Untagged” designation for a port VLAN assignment where the port is connected to non 802.1Q-compliant device or is assigned to only one VLAN. Use the “Tagged” designation when the port is assigned to more than one VLAN or the port is connected to a device that *does* comply with the 802.1Q standard.

For example, if port A7 on an 802.1Q-compliant switch is assigned to only the Red VLAN, the assignment can remain “untagged” because the port will forward traffic only for the Red VLAN. However, if both the Red and Green VLANs are assigned to port A7, then at least one of those VLAN assignments must be “tagged” so that Red VLAN traffic can be distinguished from Green VLAN traffic. The following illustration shows this concept:

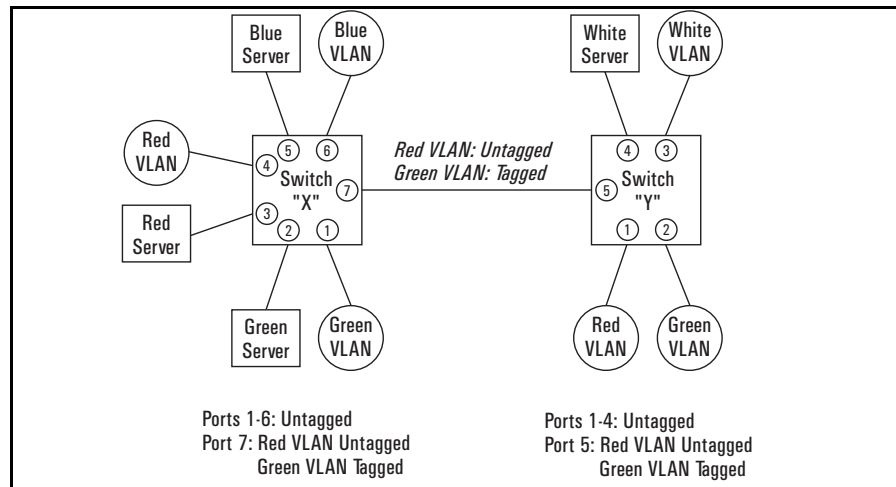

Figure 11-17. Example of Tagged and Untagged VLAN Port Assignments

- In switch X:
  - VLANs assigned to ports X1 - X6 can all be untagged because there is only one VLAN assignment per port. Red VLAN traffic will go out only the Red ports; Green VLAN traffic will go out only the Green ports, and so on. Devices connected to these ports do not have to be 802.1Q-compliant.
  - However, because both the Red VLAN and the Green VLAN are assigned to port X7, at least one of the VLANs must be tagged for this port.
- In switch Y:
  - VLANs assigned to ports Y1 - Y4 can all be untagged because there is only one VLAN assignment per port. Devices connected to these ports do not have to be 802.1Q-compliant.
  - Because both the Red VLAN and the Green VLAN are assigned to port Y5, at least one of the VLANs must be tagged for this port.
- In both switches: The ports on the link between the two switches must be configured the same. As shown in figure 11-17 (above), the Red VLAN must be untagged on port X7 and Y5 and the Green VLAN must be tagged on port X7 and Y5, or vice-versa.

---

**Note**

Each 802.1Q-compliant VLAN must have its own unique VID number, and that VLAN *must* be given the same VID in every device in which it is configured. That is, if the Red VLAN has a VID of 10 in switch X, then 10 must also be used for the Red VID in switch Y.

---

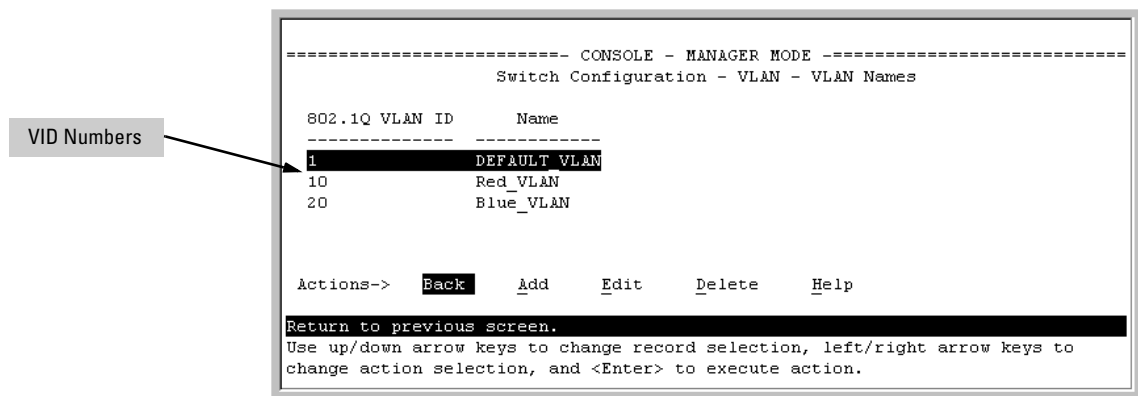
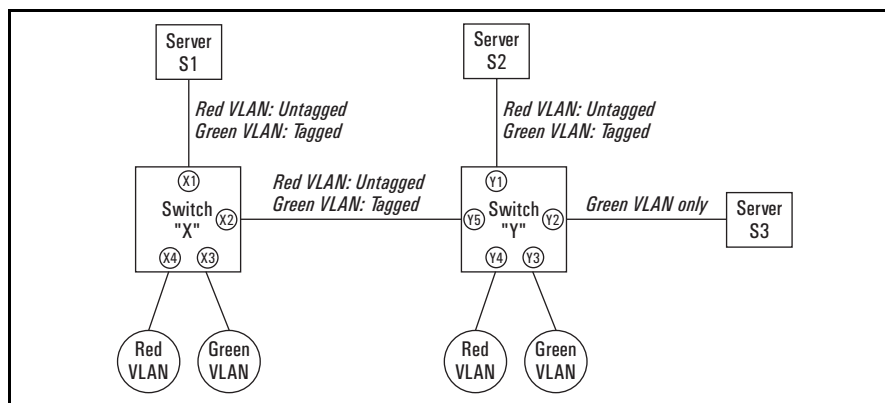

**Figure 11-18. Example of VLAN ID Numbers Assigned in the VLAN Names Screen**

VLAN tagging gives you several options:

- Since the purpose of VLAN tagging is to allow multiple VLANs on the same port, any port that has only one VLAN assigned to it can be configured as “Untagged” (the default).
- Any port that has two or more VLANs assigned to it can have one VLAN assignment for that port as “Untagged”. All other VLANs assigned to the same port must be configured as “Tagged”. (There can be no more than one Untagged VLAN on a port.)
- If all end nodes on a port comply with the 802.1Q standard and are configured to use the correct VID, then, you can configure all VLAN assignments on a port as “Tagged” if doing so makes it easier to manage your VLAN assignments, or for security reasons.

For example, in the following network, switches X and Y and servers S1 and S2 are 802.1Q-compliant. (Server S3 could also be 802.1Q-compliant, but it makes no difference for this example.)



**Figure 11-19. Example of Networked 802.1Q-Compliant Devices with Multiple VLANs on Some Ports**



The VLANs assigned to ports X3, X4, Y2, Y3, and Y4 can all be untagged because there is only one VLAN assigned per port. Port X1 has multiple VLANs assigned, which means that one VLAN assigned to this port can be untagged and any others must be tagged. The same applies to ports X2, Y1, and Y5.

Switch X			Switch Y		
Port	Red VLAN	Green VLAN	Port	Red VLAN	Green VLAN
X1	Untagged	Tagged	Y1	Untagged	Tagged
X2	Untagged	Tagged	Y2	No*	Untagged
X3	No*	Untagged	Y3	No*	Untagged
X4	Untagged	No*	Y4	Untagged	No*
			Y5	Untagged	Tagged

\*"No" means the port is not a member of that VLAN. For example, port X3 is not a member of the Red VLAN and does not carry Red VLAN traffic. Also, if GVRP were enabled, "Auto" would appear instead of "No".

---

**Note**

VLAN configurations on ports connected by the same link must match. Because ports X2 and Y5 are opposite ends of the same point-to-point connection, both ports must have the same VLAN configuration; that is, both ports configure the Red VLAN as "Untagged" and the Green VLAN as "Tagged".

To summarize:

VLANs Per Port	Tagging Scheme
1	Untagged or Tagged. If the device connected to the port is 802.1Q-compliant, then the recommended choice is "Tagged".
2 or More	1 VLAN Untagged; all others Tagged or All VLANs Tagged

A given VLAN *must* have the same VID on any 802.1Q-compliant device in which the VLAN is configured.

The ports connecting two 802.1Q devices should have identical VLAN configurations, as shown for ports X2 and Y5, above.

## The Secure Management VLAN

Configures a secure Management VLAN by creating an isolated network for managing the HP Procurve switches that support this feature. (As of June 1, 2002, includes the HP Procurve Series 4100GL switches and Series 5300XL switches.) Access to this VLAN, and to the switch's management functions (Menu, CLI, and web browser interface) is available only through ports configured as members.

- Multiple ports on the switch can belong to the Management VLAN. This allows connections for multiple management stations you want to have access to the Management VLAN, while at the same time allowing Management VLAN links between switches configured for the same Management VLAN.
- Only traffic from the Management VLAN can manage the switch, which means that only the workstations and PCs connected to ports belonging to the Management VLAN can manage and reconfigure the switch.

Figure 11-20 illustrates use of the Management VLAN feature to support management access by a group of management workstations.

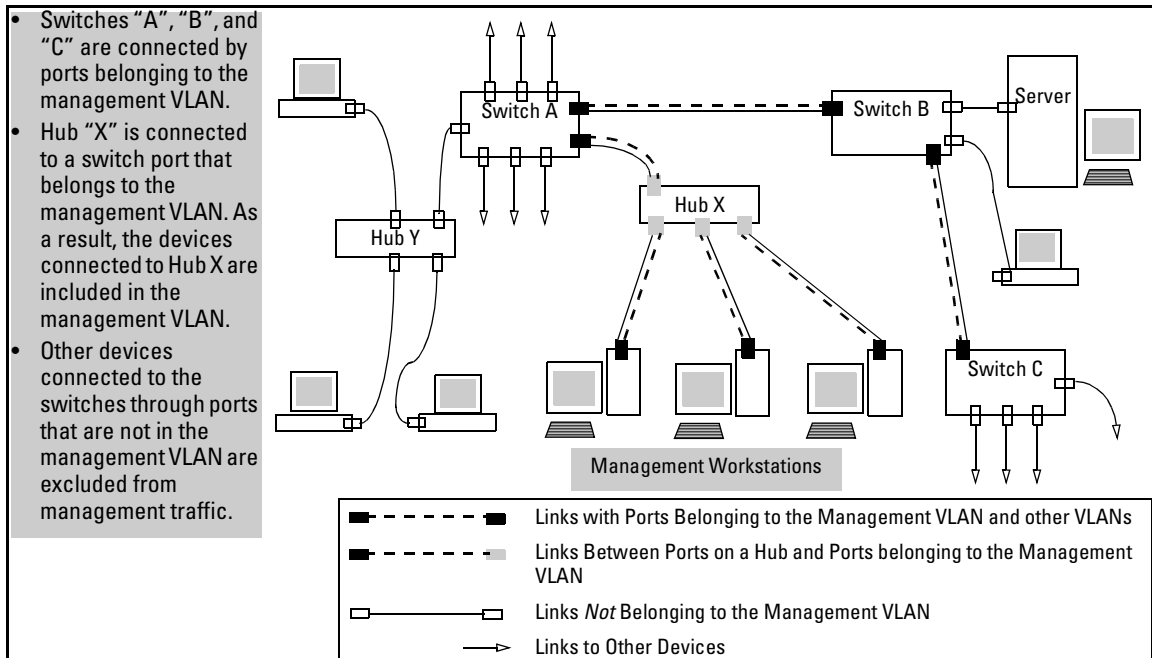

**Figure 11-20. Example of Potential Security Breaches**

In figure 11-21, Workstation 1 has management access to all three switches through the Management VLAN, while the PCs do not. This is because configuring a switch to recognize a Management VLAN automatically excludes attempts to send management traffic from any other VLAN.

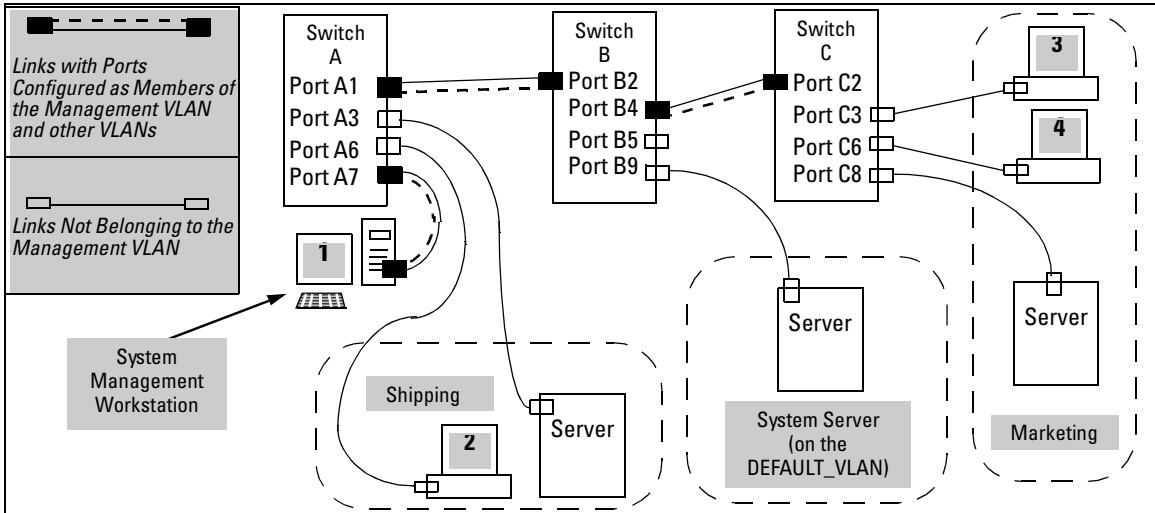

Figure 11-21. Example of Management VLAN Control in a LAN

Table 11-2. VLAN Membership in Figure 11-21

Switch	A1	A3	A6	A7	B2	B4	B5	B9	C2	C3	C6	C8
Management VLAN (VID = 7)	Y	N	N	Y	Y	Y	N	N	Y	N	N	N
Marketing VLAN (VID = 12)	N	N	N	N	N	N	N	N	N	Y	Y	Y
Shipping Dept. VLAN (VID = 20)	N	Y	Y	N	N	N	N	N	N	N	N	N
DEFAULT-VLAN (VID = 1)	Y	Y	Y	Y	Y	Y	Y	Y	Y	Y	Y	Y

### Preparation

1. Determine a VID and VLAN name suitable for your Management VLAN.
2. Determine the IP addressing for the Management VLAN (**DHCP/Bootp** or **Manual**).
3. Plan your Management VLAN topology to use HP Procurve switches that support this feature. (As of June 1, 2002, this includes the HP Procurve Series 5300XL and Series 4100GL switches.) The ports belonging to the Management VLAN should be only the following:
  - Ports to which you will connect authorized management stations (such as Port A7 in figure 11-21.)

- Ports on one switch that you will use to extend the Management VLAN to ports on other HP Procurve switches (such as ports A1 and B2 or B4 and C2 in figure 11-21 on page 11-27.).

Hubs dedicated to connecting management stations to the Management VLAN can also be included in the above topology. Note that any device connected to a hub in the Management VLAN will also have Management VLAN access.

4. Configure the Management VLAN on the selected switch ports.
5. Test the management VLAN from all of the management stations authorized to use the Management VLAN, including any SNMP-based network management stations. Ensure that you include testing any Management VLAN links between switches.

---

**Note**

---

If you configure a Management VLAN on a switch by using a Telnet connection through a port that is not in the Management VLAN, then you will lose management contact with the switch if you log off your Telnet connection or execute **write memory** and **reboot** the switch.

### Configuration

**Syntax:** [ no ] management-vlan < vlan-id | vlan-name >  
show vlan-info

**Default:** Disabled

For example, suppose you have already configured a VLAN named **My\_VLAN** with a VID of 100 in a Series 4100GL switch. Now you want to configure the switch to do the following:

- Use **My\_VLAN** as a Management VLAN (tagged, in this case) to connect port A1 on switch “A” to a management station. (The management station includes a network interface card with 802.1Q tagged VLAN capability.)
- Use port A2 to extend the Management VLAN to port B1 (which is already configured as a tagged member of **My\_VLAN**) on an adjacent Series 4100GL switch.

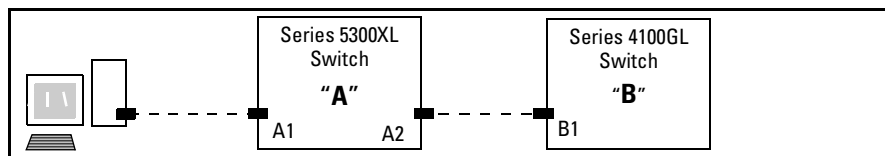

**Figure 11-22. Illustration of Configuration Example**

```
HPswitch (config)# management-vlan 100
HPswitch (config)# vlan 100 tagged a1
HPswitch (config)# vlan 100 tagged a2
```

**Deleting the Management VLAN.** You can disable the Secure Management feature without deleting the VLAN itself. For example, either of the following commands disables the Secure Management feature in the above example:

```
HPswitch (config)# no management-vlan 100
HPswitch (config)# no management-vlan my_vlan
```

## Operating Notes for Management VLANs

- If there are more than 25 VLANs configured on the switch, reboot the switch after configuring the management VLAN. (*HP Series 5300XL switches only.*)
- If you implement a Management VLAN in a switch mesh environment, all meshed ports on Series 5300XL switches will be members of the Management VLANs.
- Only one Management-VLAN can be active in the switch. If one Management-VLAN VID is saved in the startup-config file and you configure a different VID in the running-config file, the switch uses the running-config version until you either use the **write-memory** command or reboot the switch.
- During a Telnet session to the switch, if you configure the Management-VLAN to a VID that excludes the port through which you are connected to the switch, you will continue to have access only until you terminate the session by logging out or rebooting the switch.
- During a web browser session to the switch, if you configure the Management-VLAN to a VID that excludes the port through which you are connected to the switch, you will continue to have access only until you close the browser session or rebooting the switch.

---

### Note

---

The Management-VLAN feature does not control management access through a direct connection to the switch's serial port.

- Enabling Spanning Tree where there are multiple links using separate VLANs, including the Management VLAN, between a pair of switches, Spanning Tree will force the blocking of one or more links. This may include the link carrying the Management VLAN, which will cause loss of management access to some devices.

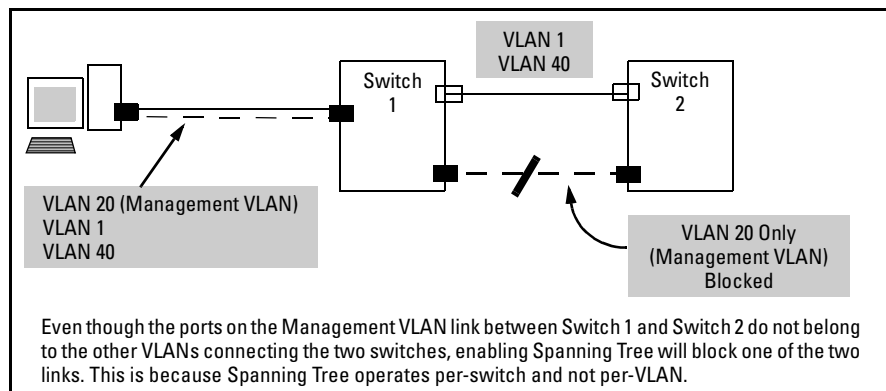

**Figure 11-23. Example of Inadvertently Blocking a Management VLAN Link by Implementing Spanning Tree**

## Effect of VLANs on Other Switch Features

### Spanning Tree Operation with VLANs

Because the Series 4100GL switches follows the 802.1Q VLAN recommendation to use single-instance spanning tree, Spanning Tree operates across all ports on the switch (regardless of VLAN assignments) instead of on a per-VLAN basis. This means that if redundant physical links exist between the switch and another 802.1Q device, all but one link will be blocked, regardless of whether the redundant links are in separate VLANs. However, you can use port trunking to prevent Spanning Tree from unnecessarily blocking ports (and to improve overall network performance). Refer to “Spanning Tree Operation with 802.1Q VLANs” on page 13-4.

Note that Spanning Tree operates differently in different devices. For example, in the (obsolete, non-802.1Q) HP Switch 2000 and the HP Switch 800T, Spanning Tree operates on a per-VLAN basis, allowing redundant physical links as long as they are in separate VLANs.

### IP Interfaces

There is a one-to-one relationship between a VLAN and an IP network interface. Since the VLAN is defined by a group of ports, the state (up/down) of those ports determines the state of the IP network interface associated with that VLAN. When a VLAN comes up because one or more of its ports is up, the

IP interface for that VLAN is also activated. Likewise, when a VLAN is deactivated because all of its ports are down, the corresponding IP interface is also deactivated.

## VLAN MAC Addresses

The switch has one unique MAC address for each of its VLAN interfaces. You can send an 802.2 test packet to this MAC address to verify connectivity to the switch. Likewise, you can assign an IP address to the VLAN interface, and when you Ping that address, ARP will resolve the IP address to this MAC address. The switch allows up to 30 VLAN MAC addresses (one per possible VLAN).

## Port Trunks

When assigning a port trunk to a VLAN, all ports in the trunk are automatically assigned to the same VLAN. You cannot split trunk members across multiple VLANs. Also, a port trunk is tagged, untagged, or excluded from a VLAN in the same way as for individual, untrunked ports.

## Port Monitoring

If you designate a port on the switch for network monitoring, this port will appear in the Port VLAN Assignment screen and can be configured as a member of any VLAN. For information on how broadcast, multicast, and unicast packets are tagged inside and outside of the VLAN to which the monitor port is assigned, see “VLAN-Related Problems” on page C-18.

## VLAN Restrictions

- A port must be a member of at least one VLAN. In the factory default configuration, all ports are assigned to the default VLAN (DEFAULT\_VLAN; VID = 1).
- A port can be assigned to several VLANs, but only one of those assignments can be untagged. (The “Untagged” designation enables VLAN operation with non 802.1Q-compliant devices.)
- An external router must be used to communicate between tagged VLANs on the switch.
- Before you can delete a VLAN, you must first re-assign all ports in the VLAN to another VLAN.

**Port-Based Virtual LANs (VLANs) and GVRP**  
Port-Based Virtual LANs (Static VLANs)

**HP Router Requirements.** *Use the Hewlett-Packard version A.09.70 (or later) router OS release if any of the following Hewlett-Packard routers are installed in networks in which you will be using VLANs:*

- HP Router 440 (formerly Router ER)
- HP Router 470 (formerly Router LR)
- HP Router 480 (formerly Router BR)
- HP Router 650

Release A.09.74 is available on the World Wide Web at

**<http://www.hp.com/go/hpprocurve>**

Click on **software**, then **routers**.



## GVRP

Feature	Default	Menu	CLI	Web
view GVRP configuration	n/a	page 11-42	page 11-43	page 11-46
list static and dynamic VLANs on a GVRP-enabled switch	n/a	—	page 11-45	page 11-46
enable or disable GVRP	disabled	page 11-42	page 11-44	page 11-46
enable or disable GVRP on individual ports	enabled	page 11-42	page 11-44	—
control how individual ports will handle advertisements for new VLANs	Learn	page 11-42	page 11-44	page 11-46
convert a dynamic VLAN to a static VLAN	n/a	—	page 11-46	—
configure static VLANs	DEFAULT_VLAN (VID = 1)	page 11-10	page 11-15	page 11-46

GVRP—GARP VLAN Registration Protocol—is an application of the Generic Attribute Registration Protocol—GARP. GVRP is defined in the IEEE 802.1Q standard, and GARP is defined in the IEEE 802.1D-1998 standard.

### Note

To understand and use GVRP you must have a working knowledge of 802.1Q VLAN tagging. (See “Port-Based Virtual LANs (Static VLANs)” on page 11-3.)

GVRP uses “GVRP Bridge Protocol Data Units” (“GVRP BPDUs”) to “advertise” static VLANs. In this manual, a GVRP BPDU is termed an *advertisement*. Advertisements are sent outbound from ports on a switch to the devices directly connected to those ports.

GVRP enables the Series 4100GL switches to dynamically create 802.1Q-compliant VLANs on links with other devices running GVRP. This enables the switch to automatically create VLAN links between GVRP-aware devices. (A GVRP link can include intermediate devices that are not GVRP-aware.) This operation reduces the chances for errors in VLAN configuration by automatically providing VLAN ID (VID) consistency across the network. That is, you can use GVRP to propagate VLANs to other GVRP-aware devices instead of manually having to set up VLANs across your network. After the switch creates a dynamic VLAN, you can optionally use the CLI **static <vlan-id>** command to convert it to a static VLAN or allow it to continue as a dynamic VLAN for as long as needed. You can also use GVRP to dynamically enable port membership in static VLANs configured on a switch.

## General Operation

When GVRP is enabled on a switch, the VID for any static VLANs configured on the switch is *advertised* (using BPDUs—Bridge Protocol Data Units) out all ports, regardless of whether a port is up or assigned to any particular VLAN. A GVRP-aware port on another device that receives the advertisements over a link can dynamically join the advertised VLAN.

A dynamic VLAN (that is, a VLAN learned through GVRP) is tagged on the port on which it was learned. Also, a GVRP-enabled port can forward an advertisement for a VLAN it learned about from other ports on the same switch (internal source), but the forwarding port will not itself join that VLAN until an advertisement for that VLAN is received through a link from another device (external source) on that specific port

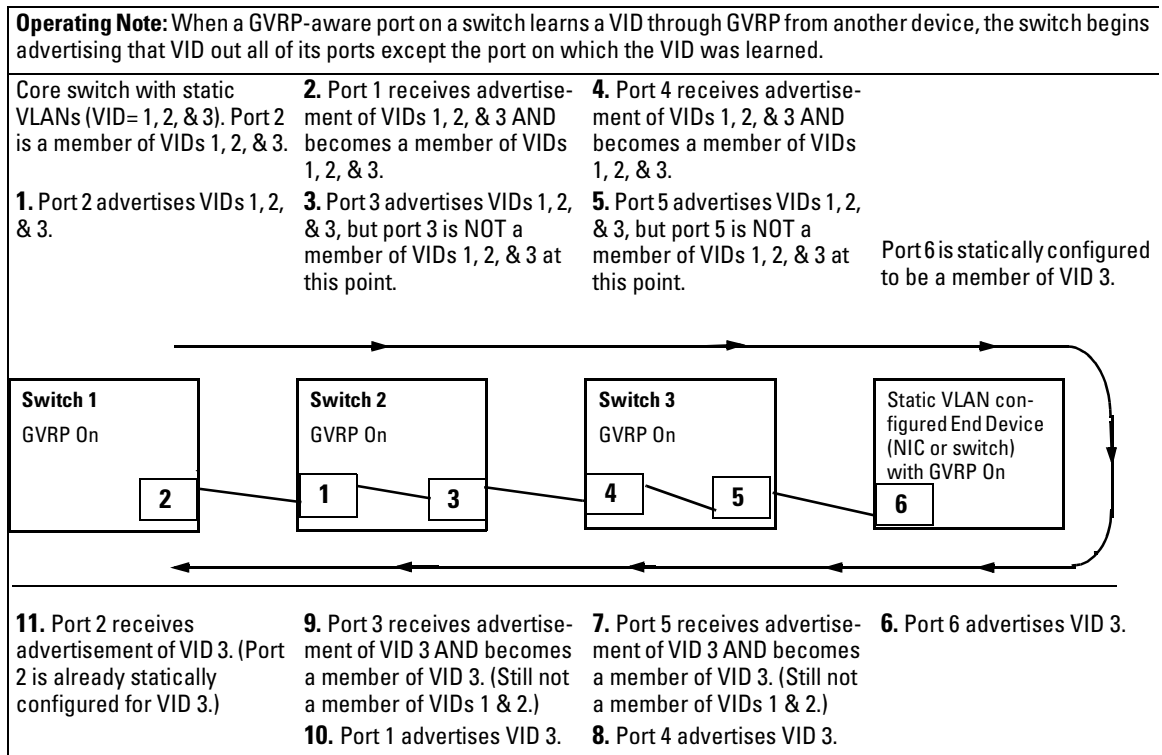

**Figure 11-24. .Example of Forwarding Advertisements and Dynamic Joining**

Note that if a static VLAN is configured on at least one port of a switch, and that port has established a link with another device, then all other ports of that switch will send advertisements for that VLAN.

For example, in the following figure, Tagged VLAN ports on switch “A” and switch “C” advertise VLANs 22 and 33 to ports on other GVRP-enabled switches that can dynamically join the VLANs.

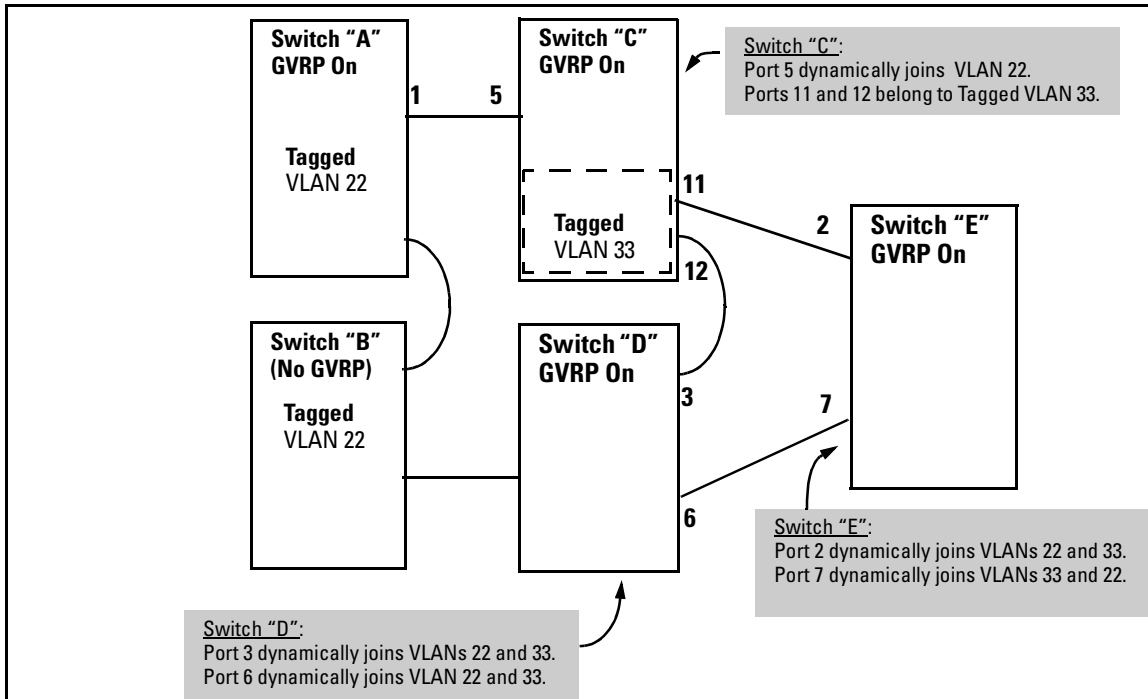

Figure 11-25. Example of GVRP Operation

**Note**

A port can learn of a dynamic VLAN through devices that are not aware of GVRP (Switch “B”, above). VLANs must be disabled in GVRP-unaware devices to allow tagged packets to pass through.

A GVRP-aware port receiving advertisements has these options:

- If there is not already a static VLAN with the advertised VID on the receiving port, then dynamically create the VLAN and become a member.
- If the switch already has a static VLAN assignment with the same VID as in the advertisement, and the port is configured to **Auto** for that VLAN, then the port will dynamically join the VLAN and begin moving that VLAN’s traffic. (For more detail on **Auto**, see “Per-Port Options for Dynamic VLAN Advertising and Joining” on page 11-38.)
- Ignore the advertisement for that VID.
- Don’t participate in that VLAN.

Note also that a port belonging to a Tagged or Untagged static VLAN has these configurable options:

- Send VLAN advertisements, and also receive advertisements for VLANs on other ports and dynamically join those VLANs.
- Send VLAN advertisements, but ignore advertisements received from other ports.
- Avoid GVRP participation by not sending advertisements and dropping any advertisements received from other devices.

**IP Addressing.** A dynamic VLAN does not have an IP address, and moves traffic on the basis of port membership in VLANs. However, after GVRP creates a dynamic VLAN, you can convert it to a static VLAN. Note that it is then necessary to assign ports to the VLAN in the same way that you would for a static VLAN that you created manually. In the static state you can configure IP addressing on the VLAN and access it in the same way that you would any other static (manually created) VLAN.

## Per-Port Options for Handling GVRP “Unknown VLANs”

An “unknown VLAN” is a VLAN that the switch learns of by receiving an advertisement for that VLAN on a port that is not already a member of that VLAN. If the port is configured to learn unknown VLANs, then the VLAN is dynamically created and the port becomes a tagged member of the VLAN. For example, suppose that in figure 11-25 (page 11-35), port 1 on switch “A” is connected to port 5 on switch “C”. Because switch “A” has VLAN 22 statically configured, while switch “C” does not have this VLAN statically configured (and does not “Forbid” VLAN 22 on port 5), VLAN 22 is handled as an “Unknown VLAN” on port 5 in switch “C”. Conversely, if VLAN 22 was statically configured on switch C, but port 5 was not a member, port 5 would become a member when advertisements for VLAN 22 were received from switch “A”.

When you enable GVRP on a switch, you have the per-port join-request options listed in table 11-11-3:

**Table 11-3. Options for Handling “Unknown VLAN” Advertisements:**

UnknownVLAN Mode	Operation
Learn (the Default)	Enables the port to become a member of any unknown VLAN for which it receives an advertisement. Allows the port to advertise other VLANs that have at least one other port on the same switch as a member.
Block	Prevents the port from joining any new dynamic VLANs for which it receives an advertisement. Allows the port to advertise other VLANs that have at least one other port as a member.
Disable	Causes the port to ignore and drop all GVRP advertisements it receives and also prevents the port from sending any GVRP advertisements.

The CLI **show gvrp** command and the menu interface VLAN Support screen show a switch’s current GVRP configuration, including the Unknown VLAN settings.

```

HPswitch# show gvrp
GVRP support
Maximum VLANs to support : 8
GVRP Enabled : Yes
Port Type      | Unknown VLAN
-----+-----
A1  10/100TX  | Learn
A2  10/100TX  | Learn
A3  10/100TX  | Block
A4  10/100TX  | Block
A5  10/100TX  | Learn
A6  10/100TX  | Disable
A7  10/100TX  | Learn
A8  10/100TX  | Learn
.      .      .
.      .      .
.      .      .

```

**Figure 11-26. Example of GVRP Unknown VLAN Settings**

## Per-Port Options for Dynamic VLAN Advertising and Joining

**Initiating Advertisements.** As described in the preceding section, to enable dynamic joins, GVRP must be enabled and a port must be configured to Learn (the default). However, to send advertisements in your network, one or more static (**Tagged**, **Untagged**, or **Auto**) VLANs must be configured on one or more switches (with GVRP enabled), depending on your topology.

**Enabling a Port for Dynamic Joins.** You can configure a port to dynamically join a static VLAN. The join will then occur if that port subsequently receives an advertisement for the static VLAN. (This is done by using the **Auto** and **Learn** options described in table 11-11-4, below.

**Parameters for Controlling VLAN Propagation Behavior.** You can configure an individual port to actively or passively participate in dynamic VLAN propagation or to ignore dynamic VLAN (GVRP) operation. These options are controlled by the GVRP “Unknown VLAN” and the static VLAN configuration parameters, as described in the following table:

**Table 11-4. Controlling VLAN Behavior on Ports with Static VLANs**

Per-Port "Unknown VLAN" (GVRP) Configuration	Static VLAN Options—Per VLAN Specified on Each Port <sup>1</sup>		
	Port Activity: Tagged or Untagged (Per VLAN) <sup>2</sup>	Port Activity: Auto <sup>2</sup> (Per VLAN)	Port Activity: Forbid (Per VLAN) <sup>2</sup>
Learn (the Default)	<p>The port:</p> <ul style="list-style-type: none"> <li>• Belongs to specified VLAN.</li> <li>• Advertises specified VLAN.</li> <li>• Can become a member of dynamic VLANs for which it receives advertisements.</li> <li>• Advertises dynamic VLANs that have at least one other port (on the same switch) as a member.</li> </ul>	<p>The port:</p> <ul style="list-style-type: none"> <li>• Will become a member of specified VLAN if it receives advertisements for specified VLAN from another device.</li> <li>• Will advertise specified VLAN.</li> <li>• Can become a member of other, dynamic VLANs for which it receives advertisements.</li> <li>• Will advertise a dynamic VLAN that has at least one other port (on the same switch) as a member.</li> </ul>	<p>The port:</p> <ol style="list-style-type: none"> <li>1. Will not become a member of the specified VLAN.</li> <li>1. Will not advertise specified VLAN.</li> <li>1. Can become a member of other dynamic VLANs for which it receives advertisements.</li> <li>1. Will advertise a dynamic VLAN that has at least one other port on the same switch as a member.</li> </ol>
Block	<p>The port:</p> <ul style="list-style-type: none"> <li>• Belongs to the specified VLAN.</li> <li>• Advertises this VLAN.</li> <li>• Will not become a member of new dynamic VLANs for which it receives advertisements.</li> <li>• Will advertise dynamic VLANs that have at least one other port as a member.</li> </ul>	<p>The port:</p> <ul style="list-style-type: none"> <li>• Will become a member of specified VLAN if it receives advertisements for this VLAN.</li> <li>• Will advertise this VLAN.</li> <li>• Will not become a member of new dynamic VLANs for which it receives advertisements.</li> <li>• Will advertise dynamic VLANs that have at least one other port (on the same switch) as a member.</li> </ul>	<p>The port:</p> <ul style="list-style-type: none"> <li>• Will not become a member of the specified VLAN.</li> <li>• Will not advertise this VLAN.</li> <li>• Will not become a member of dynamic VLANs for which it receives advertisements.</li> <li>• Will advertise dynamic VLANs that have at least one other port (on the same switch) as a member.</li> </ul>
Disable	<p>The port:</p> <ul style="list-style-type: none"> <li>• Is a member of the specified VLAN.</li> <li>• Will ignore GVRP PDUs.</li> <li>• Will not join any advertised VLANs.</li> <li>• Will not advertise VLANs.</li> </ul>	<p>The port:</p> <ul style="list-style-type: none"> <li>• Will not become a member of the specified VLAN.</li> <li>• Will ignore GVRP PDUs.</li> <li>• Will not join any dynamic VLANs.</li> <li>• Will not advertise VLANs.</li> </ul>	<p>The port:</p> <ul style="list-style-type: none"> <li>• Will not become a member of this VLAN.</li> <li>• Will ignore GVRP PDUs.</li> <li>• Will not join any dynamic VLANs.</li> <li>• Will not advertise VLANs.</li> </ul>

<sup>1</sup> Each port of a Series 4100GL switches must be a Tagged or Untagged member of at least one VLAN. Thus, any port configured for GVRP to Learn or Block will generate and forward advertisements for static VLAN(s) configured on the switch and also for dynamic VLANs the switch learns on other ports. .

<sup>2</sup> To configure tagging, **Auto**, or **Forbid**, see "Configuring Static VLAN Name and Per-Port Settings" on page 11-20 (for the CLI) or "Adding or Changing a VLAN Port Assignment" on page 11-13 (for the menu).

As the preceding table indicates, when you enable GVRP, a port that has a Tagged or Untagged static VLAN has the option for both generating advertisements and dynamically joining other VLANs.

---

**Note**

In table 11-11-4, above, the Unknown VLAN parameters are configured on a per-port basis using the CLI. The Tagged, Untagged, Auto, and Forbid options are configured per static VLAN on every port, using either the menu interface or the CLI.

Because dynamic VLANs operate as Tagged VLANs, and because a tagged port on one device cannot communicate with an untagged port on another device, HP recommends that you use Tagged VLANs for the static VLANs you will use to generate advertisements.

---

## GVRP and VLAN Access Control

When you enable GVRP on a switch, the default GVRP parameter settings allow all of the switch's ports to transmit and receive dynamic VLAN advertisements (GVRP advertisements) and to dynamically join VLANs. The two preceding sections describe the per-port features you can use to control and limit VLAN propagation. To summarize, you can:

- Allow a port to advertise and/or join dynamic VLANs (Learn mode—the default).
- Allow a port to send VLAN advertisements, but not receive them from other devices; that is, the port cannot dynamically join a VLAN but other devices can dynamically join the VLANs it advertises (Block mode).
- Prevent a port from participating in GVRP operation (Disable mode).

### Port-Leave From a Dynamic VLAN

A dynamic VLAN continues to exist on a port for as long as the port continues to receive advertisements of that VLAN from another device connected to that port or until you:

- Convert the VLAN to a static VLAN (See “Converting a Dynamic VLAN to a Static VLAN” on page 11-20.)
- Reconfigure the port to **Block** or **Disable**
- Disable GVRP
- Reboot the switch

The time-to-live for dynamic VLANs is 10 seconds. That is, if a port has not received an advertisement for an existing dynamic VLAN during the last 10 seconds, the port removes itself from that dynamic VLAN.



## Planning for GVRP Operation

These steps outline the procedure for setting up dynamic VLANs for a segment.

1. Determine the VLAN topology you want for each segment (broadcast domain) on your network.
2. Determine the VLANs that must be static and the VLANs that can be dynamically propagated.
3. Determine the device or devices on which you must manually create static VLANs in order to propagate VLANs throughout the segment.
4. Determine security boundaries and how the individual ports in the segment will handle dynamic VLAN advertisements. (See table 11-11-3 on page 11-37 and table 11-11-4 on page 11-39.)
5. Enable GVRP on all devices you want to use with dynamic VLANs and configure the appropriate “Unknown VLAN” parameter (**Learn**, **Block**, or **Disable**) for each port.
6. Configure the static VLANs on the switch(es) where they are needed, along with the per-VLAN parameters (**Tagged**, **Untagged**, **Auto**, and **Forbid**—see table 11-11-4 on page 11-39) on each port.
7. Dynamic VLANs will then appear automatically, according to the configuration options you have chosen.
8. Convert dynamic VLANs to static VLANs where you want dynamic VLANs to become permanent.

## Configuring GVRP On a Switch

The procedures in this section describe how to:

- View the GVRP configuration on a switch
- Enable and disable GVRP on a switch
- Specify how individual ports will handle advertisements

To view or configure static VLANs for GVRP operation, refer to “Per-Port Static VLAN Configuration Options” on page 11-7.

## Menu: Viewing and Configuring GVRP

- From the Main Menu, select:

### 2. Switch Configuration . . .

### 8. VLAN Menu . . .

### 1. VLAN Support

```

----- CONSOLE - MANAGER MODE -----
                Switch Configuration - VLAN - VLAN Support

Maximum VLANs to support [8] : 8
Primary VLAN : DEFAULT_VLAN
GVRP Enabled [No] : No

Actions->  Cancel    Edit    Save    Help

Cancel changes and return to previous screen.
Use arrow keys to change action selection and <Enter> to execute action.
    
```

**Figure 11-27. The VLAN Support Screen (Default Configuration)**

- Do the following to enable GVRP and display the Unknown VLAN fields:
  - Press **[E]** (for **E**dit).
  - Use **[↓]** to move the cursor to the **GVRP Enabled** field.
  - Press the Space bar to select **Yes**.
  - Press **[↓]** again to display the **Unknown VLAN** fields.

The Unknown VLAN fields enable you to configure each port to:

- Learn - Dynamically join any advertised VLAN and advertise all VLANs learned through other ports.
- Block - Do not dynamically join any VLAN, but still advertise all VLANs learned through other ports.
- Disable - Ignore and drop all incoming advertisements and do not transmit any advertisements.

```

----- CONSOLE - MANAGER MODE -----
                Switch Configuration - VLAN - VLAN Support

Maximum VLANs to support [8] : 8
Primary VLAN : DEFAULT_VLAN
GVRP Enabled [No] : Yes

Port      Type      Unknown VLAN | Port      Type      Unknown VLAN
-----+-----+-----|-----+-----+-----
A1  10/100TX | Learn | A8  10/100TX | Learn
A2  10/100TX | Learn  | A9  10/100TX | Learn
A3  10/100TX | Learn  | A10 10/100TX | Learn
A4  10/100TX | Learn  | A11 10/100TX | Learn
A5  10/100TX | Learn  | A12 10/100TX | Learn
A6  10/100TX | Learn  | A13 10/100TX | Learn
A7  10/100TX | Learn  | A14 10/100TX | Learn

Actions->  Cancel    Edit    Save    Help

Use arrow keys to change field selection, <Space> to toggle field choices,
and <Enter> to go to Actions.
    
```

**Figure 11-28. Example Showing Default Settings for Handling Advertisements**

3. Use the arrow keys to select the port you want, and the Space bar to select Unknown VLAN option for any ports you want to change.
4. When you finish making configuration changes, press `[Enter]`, then `[S]` (for **Save**) to save your changes to the Startup-Config file.

## CLI: Viewing and Configuring GVRP

### GVRP Commands Used in This Section

show gvrp	below
gvrp	page 11-44
unknown-vlans	page 11-44

**Displaying the Switch’s Current GVRP Configuration.** This command shows whether GVRP is disabled, along with the current settings for the maximum number of VLANs and the current Primary VLAN. (For more on the last two parameters, see “Port-Based Virtual LANs (Static VLANs)” on page 11-3.)

**Syntax:**    show gvrp                               Shows the current settings.

```
HPswitch> show gvrp
GVRP support
  Maximum VLANs to support : 8
  Primary VLAN : DEFAULT_VLAN
  GVRP Enabled : No
```

**Figure 11-29. Example of “Show GVRP” Listing with GVRP Disabled**

```
HPswitch> show gvrp
GVRP support
  Maximum VLANs to support : 8
  Primary VLAN : DEFAULT_VLAN
  GVRP Enabled : Yes

  Port Type      | Unknown VLAN
  ----+-----
  A1  10/100TX   | Learn
  A2  10/100TX   | Learn
  A3  10/100TX   | Block
  A4  10/100TX   | Disable
  A5  10/100TX   | Disable
  A6  10/100TX   | Learn
  A7  10/100TX   | Learn
  .      .      | .
  .      .      | .
  .      .      | .
```

This example includes non-default settings for the Unknown VLAN field for some ports.

**Figure 11-30. Example of Show GVRP Listing with GVRP Enabled**

**Enabling and Disabling GVRP on the Switch.** This command enables GVRP on the switch.

**Syntax:** gvrp

This example enables GVRP:

```
HPswitch(config)# gvrp
```

This example disables GVRP operation on the switch:

```
HPswitch(config)# no gvrp
```

**Enabling and Disabling GVRP On Individual Ports.** When GVRP is enabled on the switch, use the **unknown-vlans** command to change the Unknown VLAN field for one or more ports. You can use this command at either the Manager level or the interface context level for the desired port(s).

**Syntax:** interface <port-list> unknown-vlans <learn | block | disable> Changes the Unknown VLAN field setting for the specified port(s).

For example, to change and view the configuration for ports A1-A2 to **Block**:

```
HPswitch(config)interface a1-a2 unknown-vlans block

HP4108(config)show gvrp
GVRP support
Maximum VLANs to support : 8
Primary VLAN : DEFAULT_VLAN
GVRP Enabled : Yes

Port Type      | Unknown VLAN
----+-----
1  10/100TX    | Block
2  10/100TX    | Block
3  10/100TX    | Learn
4  10/100TX    | Learn
.      .      .
.      .      .
.      .      .
```

**Figure 11-31. Example of Preventing Specific Ports from Joining Dynamic VLANs**

**Displaying the Static and Dynamic VLANs Active on the Switch.** The **show vlans** command lists all VLANs present in the switch.

**Syntax:** show vlans

For example, in the following illustration, switch “B” has one static VLAN (the default VLAN), with GVRP enabled and port 1 configured to **Learn** for Unknown VLANs. Switch “A” has GVRP enabled and has three static VLANs: the default VLAN, VLAN-222, and VLAN-333. In this scenario, switch B will dynamically join VLAN-222 and VLAN-333:

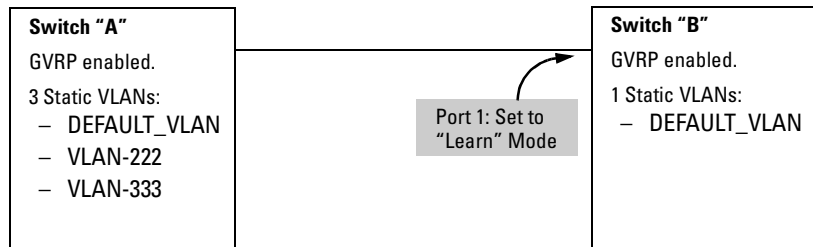

The **show vlans** command lists the dynamic (and static) VLANs in switch “B” after it has learned and joined VLAN-222 and VLAN-333.

```

Switch-B> show vlans
Status and Counters - VLAN Information

VLAN support : Yes
Maximum VLANs to support : 8
Primary VLAN : DEFAULT_VLAN

802.1Q VLAN ID Name          Status
-----
1             DEFAULT_VLAN  Static
222           GVRP_222    Dynamic
333           GVRP_333    Dynamic
  
```

Dynamic VLANs  
Learned from  
Switch "A"  
through Port 1

**Figure 11-32. Example of Listing Showing Dynamic VLANs**

**Converting a Dynamic VLAN to a Static VLAN.** If a port on the switch has joined a dynamic VLAN, you can use the following command to convert that dynamic VLAN to a static VLAN:

**Syntax:**   static <dynamic-vlan-id>

For example, to convert dynamic VLAN 333 (from the previous example) to a static VLAN:

```
HPswitch(config)# static 333
```

When you convert a dynamic VLAN to a static VLAN, all ports on the switch are assigned to the VLAN in Auto mode.

## Web: Viewing and Configuring GVRP

To view, enable, disable, or reconfigure GVRP:

1. Click on the **Configuration** tab.
2. Click on [VLAN Configuration](#) and do the following:
  - To enable or disable GVRP, click on **GVRP Enabled**.
  - To change the Unknown VLAN field for any port:
    - i. Click on [GVRP Security](#) and make the desired changes.
    - ii. Click on [Apply](#) to save and implement your changes to the Unknown VLAN fields.

For web-based Help on how to use the web browser interface screen, click on the [?](#) button provided on the web browser screen.

## GVRP Operating Notes

- A dynamic VLAN must be converted to a static VLAN before it can have an IP address.
- The total number of VLANs on the switch (static and dynamic combined) cannot exceed the current Maximum VLANs setting. For example, in the factory default state, the switch supports eight VLANs. Thus, in a case where four static VLANs are configured on the switch, the switch can accept up to four additional VLANs in any combination of static and dynamic. Any additional VLANs advertised to the switch will not be added unless you first increase the Maximum VLANs setting. In the Menu interface, click on **2. Switch Configuration ... | 8. VLAN Menu | 1. VLAN Support**. In the global config level of the CLI, use **max-vlans**.

- Converting a dynamic VLAN to a static VLAN and then executing the **write memory** command saves the VLAN in the startup-config file and makes it a permanent part of the switch's VLAN configuration.
- Within the same broadcast domain, a dynamic VLAN can pass through a device that is not GVRP-aware. This is because a hub or a switch that is not GVRP-aware will flood the GVRP (multicast) advertisement packets out all ports.
- GVRP assigns dynamic VLANs as Tagged VLANs. To configure the VLAN as Untagged, you must first convert it to a static VLAN.
- Rebooting a switch on which a dynamic VLAN exists deletes that VLAN. However, the dynamic VLAN re-appears after the reboot if GVRP is enabled and the switch again receives advertisements for that VLAN through a port configured to add dynamic VLANs.
- By receiving advertisements from other devices running GVRP, the switch learns of static VLANs on those other devices and dynamically (automatically) creates tagged VLANs on the links to the advertising devices. Similarly, the switch advertises its static VLANs to other GVRP-aware devices, as well as the dynamic VLANs the switch has learned.
- A GVRP-enabled switch does not advertise any GVRP-learned VLANs out of the port(s) on which it originally learned of those VLANs.





# Multimedia Traffic Control with IP Multicast (IGMP)

---

## Contents

<b>Overview</b> .....	12-2
<b>General Operation and Features</b> .....	12-3
IGMP Terms .....	12-4
IGMP Operating Features .....	12-5
Basic Operation .....	12-5
Enhancements .....	12-5
<b>CLI: Configuring and Displaying IGMP</b> .....	12-6
Web: Enabling or Disabling IGMP .....	12-10
<b>How IGMP Operates</b> .....	12-11
Operation With or Without IP Addressing .....	12-12
Automatic Fast-Leave IGMP .....	12-13
Forced Fast-Leave IGMP .....	12-14
Configuration Options for Forced Fast-Leave .....	12-15
Listing the Forced Fast-Leave Configuration .....	12-15
Configuring Per-Port Forced Fast-Leave IGMP .....	12-17
<b>Using the Switch as Querier</b> .....	12-18
Querier Operation .....	12-18
<b>The Switch Excludes Well-Known or Reserved Multicast Addresses from IP Multicast Filtering</b> .....	12-19
Number of IP Multicast Addresses Allowed .....	12-20

## Overview

This chapter describes the following features and how to configure them with the switch's built-in interfaces:

- **Multimedia Traffic Control with IP Multicast (IGMP):** Use the switch to reduce unnecessary bandwidth usage on a per-port basis by configuring IGMP controls.

For general information on how to use the switch's built-in interfaces, see:

- Chapter 2, "Using the Menu Interface"
- Chapter 3, "Using the Command Line Interface (CLI)"
- Chapter 4, "Using the HP Web Browser Interface"
- Appendix C, "Switch Memory and Configuration"

---

## General Operation and Features

### IGMP Features

Feature	Default	Menu	CLI	Web
view igmp configuration	n/a	—	page 12-6	—
show igmp status for multicast groups used by the selected VLAN	n/a	—	Yes	—
enabling or disabling IGMP (Requires VLAN ID Context)	disabled	—	page 12-8	page 12-10
per-port packet control	auto	—	page 12-9	—
IGMP traffic priority	normal	—	page 12-9	—
querier	enabled	—	page 12-10	—

In a network where IP multicast traffic is transmitted for various multimedia applications, you can use the switch to reduce unnecessary bandwidth usage on a per-port basis by configuring IGMP (Internet Group Management Protocol controls). In the factory default state (IGMP disabled), the switch simply floods all IP multicast traffic it receives on a given VLAN through all ports on that VLAN (except the port on which it received the traffic). This can result in significant and unnecessary bandwidth usage in networks where IP multicast traffic is a factor. Enabling IGMP allows the ports to detect IGMP queries and report packets and manage IP multicast traffic through the switch.

IGMP is useful in multimedia applications such as LAN TV, desktop conferencing, and collaborative computing, where there is multipoint communication; that is, communication from one to many hosts, or communication originating from many hosts and destined for many other hosts. In such multipoint applications, IGMP will be configured on the hosts, and multicast traffic will be generated by one or more servers (inside or outside of the local network). Switches in the network (that support IGMP) can then be configured to direct the multicast traffic to only the ports where needed. If multiple VLANs are configured, you can configure IGMP on a per-VLAN basis.

Enabling IGMP allows detection of IGMP queries and report packets in order to manage IP multicast traffic through the switch. If no other querier is detected, the switch will then also function as the querier. (If you need to disable the querier feature, you can do so through the IGMP configuration MIB. Refer to “Changing the Querier Configuration Setting” on page 12-10.)

---

**Note**

---

IGMP configuration on the Switch 4108GL operates at the VLAN context level. If you are not using VLANs, then configure IGMP in VLAN 1 (the default VLAN) context.

## IGMP Terms

- **IGMP Device:** A switch or router running IGMP traffic control features.
- **IGMP Host:** An end-node device running an IGMP (multipoint, or multicast communication) application.
- **Querier:** A required IGMP device that facilitates the IGMP protocol and traffic flow on a given LAN. This device tracks which ports are connected to devices (IGMP clients) that belong to specific multicast groups, and triggers updates of this information. A querier uses data received from the queries to determine whether to forward or block multicast traffic on specific ports. When the switch has an IP address on a given VLAN, it automatically operates as a Querier for that VLAN if it does not detect a multicast router or another switch functioning as a Querier. When enabled (the default state), the switch's querier function eliminates the need for a multicast router. In most cases, HP recommends that you leave this parameter in the default "enabled" state even if you have a multicast router performing the querier function in your multicast group. For more information, see "How IGMP Operates" on page 12-11.

## IGMP Operating Features

### Basic Operation

In the factory default configuration, IGMP is disabled. If multiple VLANs are not configured, you must configure IGMP on the default VLAN (DEFAULT\_VLAN; VID = 1). If multiple VLANs are configured, you must configure IGMP on a per-VLAN basis for every VLAN where this feature is desired.

### Enhancements

With the CLI, you can configure these additional options:

- **Forward with High Priority.** Disabling this parameter (the default) causes the switch or VLAN to process IP multicast traffic, along with other traffic, in the order received (usually, normal priority). Enabling this parameter causes the switch or VLAN to give a higher priority to IP multicast traffic than to other traffic.
- **Auto/Blocked/Forward:** You can use the console to configure individual ports to any of the following states:
  - **Auto** (the default): Causes the switch to interpret IGMP packets and to filter IP multicast traffic based on the IGMP packet information for ports belonging to a multicast group. This means that IGMP traffic will be forwarded on a specific port only if an IGMP host or multicast router is connected to the port.
  - **Blocked:** Causes the switch to drop all IGMP transmissions received from a specific port and to block all outgoing IP Multicast packets for that port. This has the effect of preventing IGMP traffic from moving through specific ports.
  - **Forward:** Causes the switch to forward all IGMP and IP multicast transmissions through the port.
- **Operation With or Without IP Addressing:** This feature helps to conserve IP addresses by enabling IGMP to run on VLANs that do not have an IP address. See “Operation With or Without IP Addressing” on page 12-12.
- **Fast-Leave IGMP:** This automatic feature reduces leave delays, which helps to reduce unnecessary multicast traffic. See “Automatic Fast-Leave IGMP” on page 12-13.
- **Forced Fast-Leave IGMP:** Where a port is connected to multiple end nodes, this feature speeds up the process of blocking unnecessary IGMP traffic to the port.

- **Querier Capability:** The switch performs this function for IGMP on VLANs having an IP address when there is no other device in the VLAN acting as querier. See “Querier Operation” on page 12-18.

---

#### Notes

Whenever IGMP is enabled, the switch generates an Event Log message indicating whether querier functionality is enabled.

IP multicast traffic groups are identified by IP addresses in the range of 224.0.0.0 to 239.255.255.255. Also, incoming IGMP packets intended for reserved, or “well-known” multicast addresses automatically flood through all ports (except the port on which the packets entered the switch). For more on this topic, see “The Switch Excludes Well-Known or Reserved Multicast Addresses from IP Multicast Filtering” on page 12-19.

For more information, refer to “How IGMP Operates” on page 12-11.

---

## CLI: Configuring and Displaying IGMP

### IGMP Commands Used in This Section

---

show ip igmp configuration	page 12-7
ip igmp	page 12-8
high-priority-forward	page 12-9
auto <[ethernet] <port-list>	page 12-9
blocked <[ethernet] <port-list>	page 12-9
forward <[ethernet] <port-list>	page 12-9
querier	page 12-10
show ip igmp	See “Internet Group Management Protocol (IGMP) Status” on page B-19.

---

**Viewing the Current IGMP Configuration.** This command lists the IGMP configuration for all VLANs configured on the switch or for a specific VLAN.

**Syntax:**      show ip igmp config                      IGMP configuration for all VLANs on the switch  
                   show ip igmp vlan <vid> config      IGMP configuration for a specific VLAN on the switch, including per-port data

(For IGMP operating status, see “Internet Group Management Protocol (IGMP) Status” on page B-19.)

For example, suppose you have the following VLAN and IGMP configurations on the switch:

VLAN ID	VLAN Name	IGMP Enabled	Forward with High Priority	Querier
1	DEFAULT_VLAN	Yes	No	No
22	VLAN-2	Yes	Yes	Yes
33	VLAN-3	No	No	No

You could use the CLI to display this data as follows:

```

HP4108> show ip igmp config
IGMP Service
  VLAN ID      VLAN NAME      IGMP Enabled Forward with High Priority Querier
  -----
  1            DEFAULT_VLAN  Yes           No                    No
  22           VLAN-2        Yes           Yes                    Yes
  33           VLAN-3        No            No                    Yes
  
```

**Figure 12-1. Example Listing of IGMP Configuration for All VLANs in the Switch**

The following version of the show ip igmp command includes the VLAN ID (*vid*) designation, and combines the above data with the IGMP per-port configuration:

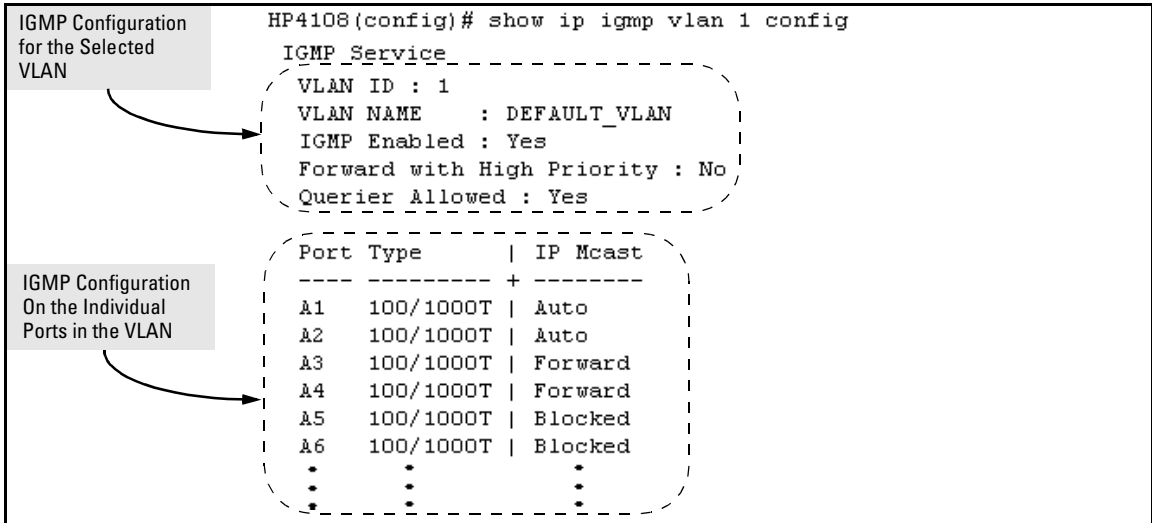

**Figure 12-2. Example Listing of IGMP Configuration for A Specific VLAN**

**Enabling or Disabling IGMP on a VLAN.** You can enable IGMP on a VLAN, along with the last-saved or default IGMP configuration (whichever was most recently set), or you can disable IGMP on a selected VLAN. Note that this command must be executed in a VLAN context.

**Syntax:** [no] ip igmp

For example, here are methods to enable and disable IGMP on the default VLAN (VID = 1).

```
HPswitch(config)# vlan 1 ip igmp      Enables IGMP on VLAN 1.
```

```
HPswitch(vlan-1)# ip igmp             Same as above.
```

```
HPswitch(config)# no vlan 1 ip igmp  Disables IGMP on VLAN 1.
```

---

**Note**

If you disable IGMP on a VLAN and then later re-enable IGMP on that VLAN, the switch restores the last-saved IGMP configuration for that VLAN. For more on how switch memory operates, see Chapter 5, “Switch Memory and Configuration”.

You can also combine the **ip igmp** command with other IGMP-related commands, as described in the following sections.



**Configuring Per-Port IGMP Packet Control.** Use this command in the VLAN context to specify how each port should handle IGMP traffic.

**Syntax:** vlan <vid> ip igmp  
[auto <port-list> | blocked <port-list> | forward <port-list>]

**Default:** auto

For example, suppose you wanted to configure IGMP as follows for VLAN 1 on the 100/1000T ports on a module in slot 1:

Ports A1-A2	auto	Filter multicast traffic. Forward IGMP traffic to hosts on these ports that belong to the multicast group for which the traffic is intended. (Also forward any multicast traffic through any of these ports that is connected to a multicast router.)
Ports A3-A4	forward	Forward all multicast traffic through this port.
Ports A5-A6	blocked	Drop all multicast traffic received from devices on these ports, and prevent any outgoing multicast traffic from moving through these ports.

Depending on the privilege level, you could use one of the following commands to configure IGMP on VLAN 1 with the above settings:

```
HPswitch(config)# vlan 1 ip igmp auto a1,a2 forward a3,a4  
blocked a5,a6
```

```
HPswitch(vlan-1)# ip igmp auto a1,a2 forward a3,a4 blocked  
a5,a6
```

The following command displays the VLAN and per-port configuration resulting from the above commands.

```
HPswitch> show ip igmp vlan 1 config
```

**Configuring IGMP Traffic Priority.** This command assigns “high” priority to IGMP traffic or returns a high-priority setting to “normal” priority. (The traffic will be serviced at its inbound priority.)

**Syntax:** vlan <vid> ip igmp high-priority-forward

**Default:** normal

```
HPswitch(config)# vlan 1 ip igmp high-priority-forward  
Configures high priority for IGMP traffic on VLAN 1.
```

```
HPswitch(vlan-1)# ip igmp high-priority-forward  
Same as above command, but in the VLAN 1 context  
level.
```

HPswitch(vlan 1)# no ip igmp high-priority-forward Returns IGMP traffic to “normal” priority.

HPswitch> show ip igmp config Show command to display results of above high-priority commands.

**Configuring the Querier Function.** The default querier capability is “enabled”. This command disables or re-enables the ability for the switch to become querier if necessary.

**Syntax:** [no] vlan <vid> ip igmp querier

**Default:** Yes

HPswitch(config)# no vlan 1 ip igmp querier Disables the querier function on VLAN 1.

HPswitch> show ip igmp config Show command to display results of above querier command.

## Web: Enabling or Disabling IGMP

In the web browser interface you can enable or disable IGMP on a per-VLAN basis. To configure other IGMP features, telnet to the switch console and use the CLI.

To Enable or Disable IGMP

1. Click on the **Configuration** tab.
2. Click on [Device Features](#).
3. If more than one VLAN is configured, use the VLAN pull-down menu to select the VLAN on which you want to enable or disable IGMP.
4. Use the Multicast Filtering (IGMP) menu to enable or disable IGMP.
5. Click on [Apply Changes](#) to implement the configuration change.

For web-based help on how to use the web browser interface screen, click on the [?](#) button provided on the web browser screen.

## How IGMP Operates

The Internet Group Management Protocol (IGMP) is an internal protocol of the Internet Protocol (IP) suite. IP manages multicast traffic by using switches, multicast routers, and hosts that support IGMP. (In Hewlett-Packard's implementation of IGMP, a multicast router is not necessary as long as a switch is configured to support IGMP with the **querier** feature enabled.) A set of hosts, routers, and/or switches that send or receive multicast data streams to or from the same source(s) is termed a *multicast group*, and all devices in the group use the same multicast group address. The multicast group running version 2 of IGMP uses three fundamental types of messages to communicate:

- **Query:** A message sent from the querier (multicast router or switch) asking for a response from each host belonging to the multicast group. If a multicast router supporting IGMP is not present, then the switch must assume this function in order to elicit group membership information from the hosts on the network. (If you need to disable the querier feature, you can do so through the CLI, using the IGMP configuration MIB. See “Changing the Querier Configuration Setting” on page “Configuring the Querier Function” on page 12-10.)
- **Report (Join):** A message sent by a host to the querier to indicate that the host wants to be or is a member of a given group indicated in the report message.
- **Leave Group:** A message sent by a host to the querier to indicate that the host has ceased to be a member of a specific multicast group.

An IP multicast packet includes the multicast group (address) to which the packet belongs. When an IGMP client connected to a switch port needs to receive multicast traffic from a specific group, it joins the group by sending an IGMP report (join request) to the network. (The multicast group specified in the join request is determined by the requesting application running on the IGMP client.) When a networking device with IGMP enabled receives the join request for a specific group, it forwards any IP multicast traffic it receives for that group through the port on which the join request was received. When the client is ready to leave the multicast group, it sends a Leave Group message to the network and ceases to be a group member. When the leave request is detected, the appropriate IGMP device will cease transmitting traffic for the designated multicast group through the port on which the leave request was received (as long as there are no other current members of that group on the affected port).

Thus, IGMP identifies members of a multicast group (within a subnet) and allows IGMP-configured hosts (and routers) to join or leave multicast groups.

**IGMP Data.** To display data showing active group addresses, reports, queries, querier access port, and active group address data (port, type, and access), see “Internet Group Management Protocol (IGMP) Status” on page B-19.

## Operation With or Without IP Addressing

You can configure IGMP on VLANs that do not have IP addressing. The benefit of IGMP without IP addressing is a reduction in the number of IP addresses you have to use and configure. This can be significant in a network with a large number of VLANs. The limitation on IGMP without IP addressing is that the switch cannot become Querier on any VLANs for which it has no IP address—so the network administrator must ensure that another IGMP device will act as Querier. It is also advisable to have an additional IGMP device available as a backup Querier. See the following table.

**Table 12-1. Comparison of IGMP Operation With and Without IP Addressing**

<b>IGMP Function Available With IP Addressing Configured on the VLAN</b>	<b>Available Without IP Addressing?</b>	<b>Operating Differences Without an IP Address</b>
Forward multicast group traffic to any port on the VLAN that has received a join request for that multicast group.	Yes	None
Forward join requests (reports) to the Querier.	Yes	None
Configure individual ports in the VLAN to <b>Auto</b> (the default)/ <b>Blocked</b> , or <b>Forward</b> .	Yes	None
Configure IGMP traffic forwarding to normal or high-priority forwarding.	Yes	None
Age-Out IGMP group addresses when the last IGMP client on a port in the VLAN leaves the group.	Yes	Requires that another IGMP device in the VLAN has an IP address and can operate as Querier. This can be a multi-cast router or another switch configured for IGMP operation. (HP recommends that the VLAN also include a device operating as a backup Querier in case the device operating as the primary Querier fails for any reason.
Support Fast-Leave IGMP (below) and Forced Fast-Leave IGMP (page 12-13).	Yes	
Support automatic Querier election.	No	Querier operation not available.
Operate as the Querier.	No	Querier operation not available.
Available as a backup Querier.	No	Querier operation not available.

## Automatic Fast-Leave IGMP

**IGMP Operation Presents a "Delayed Leave" Problem.** Where multiple IGMP clients are connected to the same port on an IGMP device (switch or router), if only one IGMP client joins a given multicast group, then later sends a Leave Group message and ceases to belong to that group, the IGMP device retains that IGMP client in its IGMP table and continues forwarding IGMP traffic to the IGMP client until the Querier triggers confirmation that no other group members exist on the same port. This means that the switch continues to transmit unnecessary multicast traffic through the port until the Querier renews multicast group status.

**Fast-Leave IGMP Reduces Leave Delays.** Fast-Leave IGMP automatically operates on a port if an IGMP client connects to the port and there are no other end nodes detected on that port. In this case, when the client leaves a multicast group, Fast-Leave IGMP automatically accelerates the blocking of further, unnecessary multicast traffic from that group to the former IGMP client. This improves performance by reducing the amount of multicast traffic going through the port to the IGMP client after the client leaves a multicast group.

**Automatic Fast-Leave Operation.** If a switch port is :

- a. Connected to only one end node
- b. The end node currently belongs to a multicast group; i.e. is an IGMP client
- c. The end node subsequently leaves the multicast group

Then the switch does not need to wait for the Querier status update interval, but instead immediately removes the IGMP client from its IGMP table and ceases transmitting IGMP traffic to the client. (If the switch detects multiple end nodes on the port, automatic Fast-Leave does not activate—regardless of whether one or more of these end nodes are IGMP clients.)

In the next figure, automatic Fast-Leave operates on the switch ports for IGMP clients "3A" and "5B", but not on the switch port for IGMP clients "7A" and 7B, Server "7C", and printer "7D".

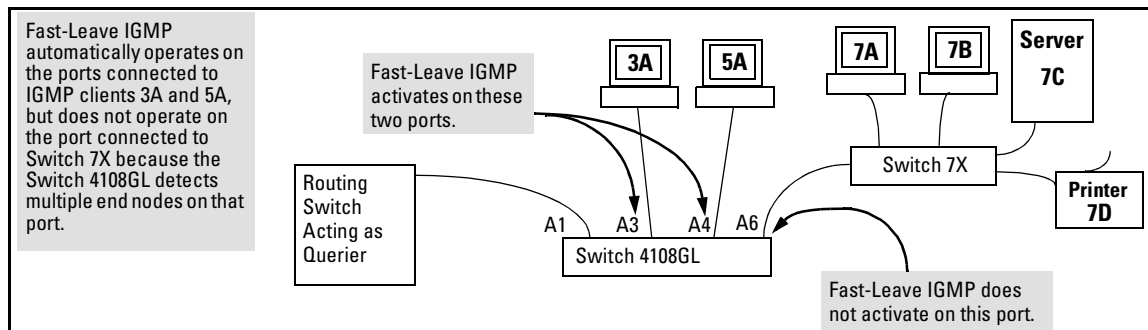

**Figure 12-3. Example of Automatic Fast-Leave IGMP Criteria**

When client "3A" running IGMP is ready to leave the multicast group, it transmits a Leave Group message. Because the switch knows that there is only one end node on port A3, it removes the client from its IGMP table and halts multicast traffic (for that group) to port A3. If the switch is not the Querier, it does not wait for the actual Querier to verify that there are no other group members on port A3. If the switch itself is the Querier, it does not query port A3 for the presence of other group members.

Note that Fast-Leave operation does not distinguish between end nodes on the same port that belong to different VLANs. Thus, for example, even if all of the devices on port A6 in figure 12-3 belong to different VLANs, Fast-Leave does not operate on port A6.

## Forced Fast-Leave IGMP

Forced Fast-Leave IGMP speeds up the process of blocking unnecessary IGMP traffic to a switch port that is connected to multiple end nodes. (This feature does not activate on ports where the switch detects only one end node. Instead, the regular Fast Leave described in the preceding section activates.) For example, in figure 12-3, even if you configured Forced Fast-Leave on all ports in the switch, the feature would activate only on port A6 (which has multiple end nodes) when a Leave Group request arrived on that port.

When a port having multiple end nodes receives a Leave Group request from one end node for a given multicast group "X", Forced Fast-Leave activates and waits a small amount of time to receive a join request from any other group "X" member on that port. If the port does not receive a join request for that group within the forced-leave interval, the switch then blocks any further group "X" traffic to the port.

## Configuration Options for Forced Fast-Leave

Feature	Default	Settings	Function
Forced Fast-Leave state	<b>2</b> (disabled)	<b>1</b> (enabled) <b>2</b> (disabled)	Uses the <b>setmib</b> command to enable or disable Forced Fast-Leave on individual ports. When enabled on a port, Forced Fast-Leave operates only if the switch detects multiple end nodes (and at least one IGMP client) on that port.

---

### Note on VLAN Numbers:

---

In the HP Procurve Switch 4108GL, the **walkmib** and **setmib** commands use an internal VLAN number (and not the VLAN ID, or VID) to display or change many per-vlan features, such as the Forced Fast-Leave state. Because the internal VLAN number for the default VLAN is always 1 (regardless of whether VLANs are enabled on the switch), and because a discussion of internal VLAN numbers for multiple VLANs is beyond the scope of this document, the discussion here concentrates on examples that use the default VLAN.

## Listing the Forced Fast-Leave Configuration

The Forced Fast-Leave configuration data is available in the switch's MIB (Management Information Base), and includes the state (enabled or disabled) for each port and the Forced-Leave Interval for all ports on the switch.

**To List the Forced Fast-Leave State for all Ports in the Switch.** Go to the switch's command prompt and use the **walkmib** command, as shown below.

1. From the Main Menu, select:

**5. Diagnostics ...**

**4. Command Prompt**

2. Do one of the following:

- If VLANs are not enabled on the switch, go to step 3.
- If VLANs are enabled on the switch:
  - i. You will be prompted to select a VLAN. For example:

```
Select VLAN : DEFAULT VLAN
```

- ii. Because you can list the Forced Fast-Leave state for all ports on the switch from any VLAN, just press **[Enter]** to select the displayed VLAN.
3. Enter either of the following walkmib command options:

```
walkmib hpSwitchIcmpPortForcedLeaveState
```

- OR -

```
walkmib 1.3.6.1.4.1.11.2.14.11.5.1.7.1.15.3.1.5
```

The resulting display lists the Forced Fast-Leave state for all ports in the switch, by VLAN. (A port belonging to more than one VLAN will be listed once for each VLAN, and if multiple VLANs are *not* configured, all ports will be listed as members of the default VLAN.) The following command produces a listing such as that shown in figure 12-4:

```
HPswitch(config)# walkmib hpswitchigmpportforcedleavestate.1
hpSwitchIgmpPortForcedLeaveState.1.1 = 2
hpSwitchIgmpPortForcedLeaveState.1.2 = 2
hpSwitchIgmpPortForcedLeaveState.1.3 = 2
hpSwitchIgmpPortForcedLeaveState.1.4 = 2
hpSwitchIgmpPortForcedLeaveState.1.5 = 1
hpSwitchIgmpPortForcedLeaveState.1.6 = 2
```

The **2** at the end of a port listing shows that Forced Fast-Leave is **disabled** on the corresponding port.

The **1** at the end of a port listing shows that Forced Fast-Leave is **enabled** on the corresponding port.

Internal VLAN Number for the Default VLAN  
**Note:** Internal VLAN numbers reflect the sequence in which VLANs are created, and are not related to the unique VID assigned to each VLAN. (See the "Note on VLAN Numbers on page 12-15.)

Sequential Port Numbers

**Ports 1-6:** 6- Port 109/1000T Module in Slot A

**Figure 12-4. Example of a Forced Fast-Leave Listing where all Ports are Members of the Default VLAN**

**To List the Forced Fast-Leave State for a Single Port.** (See the "Note on VLAN Numbers" on page 12-15.)

Go to the switch's command prompt and use the **getmib** command, as shown below.

**Syntax:**

```
getmib hpSwitchIgmpPortForcedLeaveState.<vlan number><.port number>
```

- OR -

```
getmib 1.3.6.1.4.1.11.2.14.11.5.1.7.1.15.3.1.5.<vlan number><.port number>
```

For example, the following command to list the state for port A6 (which, in this case, belongs to the default VLAN) produces the indicated listing:



```
HPswitch(config)# getmib hpswitchigmpportforcedleavestate.1.6  
hpSwitchIgmpportForcedLeaveState.1.6 = 2
```

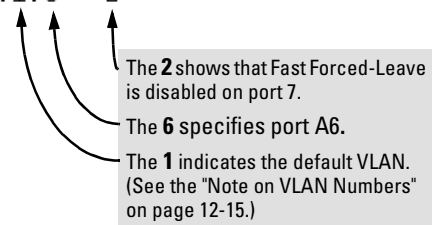

The **2** shows that Fast Forced-Leave is disabled on port 7.  
The **6** specifies port A6.  
The **1** indicates the default VLAN. (See the "Note on VLAN Numbers" on page 12-15.)

**Figure 15-5. Example Listing the Forced Fast-Leave State for a Single Port on the Default VLAN**

## Configuring Per-Port Forced Fast-Leave IGMP

In the factory-default configuration, Forced Fast-Leave is disabled for all ports on the switch. To enable (or disable) this feature on individual ports, use the switch's **setmib** command, as shown below.

**Configuring Per-Port Forced Fast-Leave IGMP on Ports.** This procedure enables or disables Forced Fast-Leave on ports in a given VLAN. (See the "Note on VLAN Numbers" on page 12-15.)

### **Syntax:**

```
setmib hpSwitchIgmpportForcedLeaveState.<vlan number><.port number>  
-i <1 | 2>
```

- OR -

```
setmib 1.3.6.1.4.1.11.2.14.11.5.1.7.1.15.3.1.5.<vlan number><.port number> -i  
<1 | 2>
```

where:

1 = Forced Fast-Leave enabled

2 = Forced Fast-Leave disabled

For example, suppose that your switch has a six-port gigabit module in slot A, and port C1 is a member of the default VLAN. In this case, the port number is "49" (In the MIB, slot A = ports 1-24; slot B = ports 25-48; slot C = ports 49-72, and so on.) To enable Forced Fast-Leave on C1 (49), you would execute the following command and see the indicated result :

## Multimedia Traffic Control with IP Multicast (IGMP) Using the Switch as Querier

```
DEFAULT_CONFIG: setmib hpSwitchIgmpportForcedLe-  
aveState.1.49 -i 1
```

```
HPswitch(config)# setmib hpswitchigmpportforcedleavestate.1.49 -i 1  
hpSwitchIgmpportForcedLeaveState.1.49 = 1
```

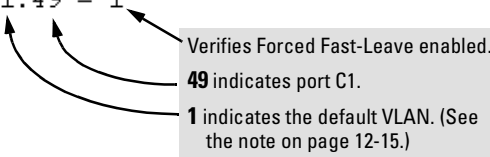

Verifies Forced Fast-Leave enabled.  
49 indicates port C1.  
1 indicates the default VLAN. (See the note on page 12-15.)

**Figure 15-6. Example of Changing the Forced Fast-Leave Configuration on Port 49**

---

## Using the Switch as Querier

### Querier Operation

The function of the IGMP Querier is to poll other IGMP-enabled devices in an IGMP-enabled VLAN to elicit group membership information. The switch performs this function if there is no other device in the VLAN, such as a multicast router, to act as Querier. Although the switch automatically ceases Querier operation in an IGMP-enabled VLAN if it detects another Querier on the VLAN, you can also use the Command Prompt to disable the Querier capability for that VLAN.

---

### Note

A Querier is required for proper IGMP operation. For this reason, if you disable the Querier function on a switch, ensure that there is an IGMP Querier (and, preferably, a backup Querier) available on the same VLAN.

If the switch becomes the Querier for a particular VLAN (for example, the DEFAULT\_VLAN), then subsequently detects queries transmitted from another device on the same VLAN, the switch ceases to operate as the Querier for that VLAN. If this occurs, the switch Event Log lists a pair of messages similar to these:

```
I 01/15/01 09:01:13 igmp: DEFAULT_VLAN: Other Querier  
detected  
I 01/15/01 09:01:13 igmp: DEFAULT_VLAN: This switch is no  
longer Querier
```

In the above scenario, if the other device ceases to operate as a Querier on the default VLAN, then the switch detects this change and can become the Querier as long as it is not pre-empted by some other IGMP Querier on the VLAN. In this case, the switch Event Log lists messages similar to the following to indicate that the switch has become the Querier on the VLAN:

```
I 01/15/01 09:21:55 igmp: DEFAULT_VLAN: Querier Election
in process
I 01/15/01 09:22:00 igmp: DEFAULT_VLAN: This switch has
been elected as Querier
```

## The Switch Excludes Well-Known or Reserved Multicast Addresses from IP Multicast Filtering

Each multicast host group is identified by a single IP address in the range of 224.0.0.0 through 239.255.255.255. Specific groups of consecutive addresses in this range are termed "well-known" addresses and are reserved for predefined host groups. IGMP does not filter these addresses, so any packets the switch receives for such addresses are flooded out all ports assigned to the VLAN on which they were received (except the port on which the packets entered the VLAN). The following table lists the 32 well-known address groups (8192 total addresses) that IGMP does not filter on the 1600M, 2400M, 2424M, 4000M, 8000M, Series 2500, and 4108GL switches.

**Table 12-2. IP Multicast Address Groups Excluded from IGMP Filtering**

Groups of Consecutive Addresses in the Range of 224.0.0.X to 239.0.0.X*		Groups of Consecutive Addresses in the Range of 224.128.0.X to 239.128.0.X*	
224.0.0.x	232.0.0.x	224.128.0.x	232.128.0.x
225.0.0.x	233.0.0.x	225.128.0.x	233.128.0.x
226.0.0.x	234.0.0.x	226.128.0.x	234.128.0.x
227.0.0.x	235.0.0.x	227.128.0.x	235.128.0.x
228.0.0.x	236.0.0.x	228.128.0.x	236.128.0.x
229.0.0.x	237.0.0.x	229.128.0.x	237.128.0.x
230.0.0.x	238.0.0.x	230.128.0.x	238.128.0.x
231.0.0.x	239.0.0.x	231.128.0.x	239.128.0.x

\* X is any value from 0 to 255.

---

**Note:**

**IP Multicast Filters.** IP multicast addresses occur in the range from 224.0.0.0 through 239.255.255.255 (which corresponds to the Ethernet multicast address range of 01005e-000000 through 01005e-7fffff). Where a switch has a static Traffic/Security filter configured with a “Multicast” filter type and a “Multicast Address” in this range, the switch will use the static filter unless IGMP learns of a multicast group destination in this range. In this case, IGMP dynamically takes over the filtering function for the multicast destination address(es) for as long as the IGMP group is active. If the IGMP group subsequently deactivates, the switch returns filtering control to the static filter. This operation applies to the HP Procurve Switch 1600M, 2400M, 2424M, 4000M, and 8000M, but *not* to the Series 2500 switches and the Switch 4108GL (which do not have static traffic/security filters).

**Reserved Addresses Excluded from IP Multicast (IGMP) Filtering.**

Traffic to IP multicast groups in the IP address range of 224.0.0.0 to 224.0.0.255 will always be flooded because addresses in this range are “well known” or “reserved” addresses. Thus, if IP Multicast is enabled and there is an IP multicast group within the reserved address range, traffic to that group will be flooded instead of filtered by the switch.

---

### Number of IP Multicast Addresses Allowed

Multicast filters and IGMP filters (addresses) together can total up to 255 in the switch. If multiple VLANs are configured, then each filter is counted once per VLAN in which it is used.

# 802.1w Rapid Spanning Tree Protocol (RSTP) and 802.1d Spanning Tree Protocol (STP)

---

## Contents

<b>Overview</b> .....	13-2
<b>How Spanning Tree Operates</b> .....	13-4
Spanning Tree Options: RSTP (802.1w) and STP (802.1d) .....	13-5
RSTP (802.1w) .....	13-5
STP (802.1d) .....	13-6
<b>Configuring Rapid Reconfiguration Spanning Tree (RSTP)</b> .....	13-7
Overview .....	13-7
Transitioning from STP to RSTP .....	13-8
Configuring RSTP .....	13-9
Optimizing the RSTP Configuration .....	13-9
CLI: Configuring RSTP .....	13-10
Menu: Configuring RSTP .....	13-16
Web: Enabling or Disabling RSTP .....	13-18
<b>802.1p Spanning-Tree Protocol (STP)</b> .....	13-19
Menu: Configuring 802.1D STP .....	13-19
CLI: Configuring 802.1D STP .....	13-22
STP Fast Mode .....	13-26
Fast-Uplink Spanning Tree Protocol (STP) .....	13-27
Terminology .....	13-29
Operating Rules for Fast Uplink .....	13-30
Menu: Viewing and Configuring Fast-Uplink STP .....	13-31
CLI: Viewing and Configuring Fast-Uplink STP .....	13-37
Operating Notes .....	13-40
<b>Web: Enabling or Disabling STP</b> .....	13-41

# Overview

## STP Features

802.1d Spanning Tree Protocol	Default	Menu	CLI	Web
viewing the STP configuration	n/a	page 13-19	page 13-10	—
enable/disable STP	disabled	page 13-19	page 13-23	page 13-41
reconfiguring general operation	priority: 32768 max age: 20 s hello time: 2 s fwd. delay: 15 s	page 13-19	page 13-24	
reconfiguring per-port STP	path cost: var priority: 128 mode: norm	page 13-19	page 13-25	
monitoring STP	n/a	page B-17	page B-17	n/a
802.1d Spanning Tree Protocol	Default	Menu	CLI	Web
Viewing the RSTP/STP configuration	--	page 13-16	page 13-10	n/a
enable/disable RSTP/STP (RSTP is selected as the default protocol)	disabled	page 13-16	page 13-11	page 13-18
reconfiguring whole-switch values	Protocol Version: RSTP Force Version: RSTP-operation Switch Priority: 8 Hello Time: 2 s Max Age: 20 s Forward Delay: 15 s	page 13-16	page 13-12	n/a
reconfiguring per-port values	Path Cost: Depends on port type Priority: 8 Edge Port: Yes Point-to-point: Force-true MCheck: Yes	page 13-16	page 13-14	n/a

Use spanning tree to ensure that only one active path at a time exists between any two nodes on the network. In networks where there is more than one physical, active path between any two nodes, enabling spanning tree ensures a single active path between such nodes by blocking all redundant paths. Without spanning tree, having more than one active path between a pair of nodes causes loops in the network, which can result in duplication of messages, leading to a “broadcast storm” that can bring down the network.

---

**Note**

You should enable spanning tree operation in any switch that is part of a redundant physical link (loop topology). (It is recommended that you do so on all switches belonging to a loop topology.) This topic is covered in more detail under “How Spanning Tree Operates” on page 13-4.

As recommended in the IEEE 802.1Q VLAN standard, the Series 4100GL switches use **single-instance STP**. (As a result, the switch generates untagged Bridge Protocol Data Units—BPDUs.) This implementation creates a single spanning tree to make sure there are no network loops associated with any of the connections to the switch, regardless of whether multiple VLANs are configured on the switch. Thus, these switches do not distinguish between VLANs when identifying redundant physical links. If VLANs are configured on the switch, see “Spanning Tree Operation with VLANs” on page 11-30.

---

## How Spanning Tree Operates

The switch automatically senses port identity and type, and automatically defines spanning-tree parameters for each type, as well as parameters that apply across the switch. You can use the default values for these parameters, or adjust them as needed.

While allowing only one active path through a network at any time, spanning tree retains any redundant physical path to serve as a backup (blocked) path in case the existing active path fails. Thus, if an active path fails, spanning tree automatically activates (unblocks) an available backup to serve as the new active path for as long as the original active path is down. For example:

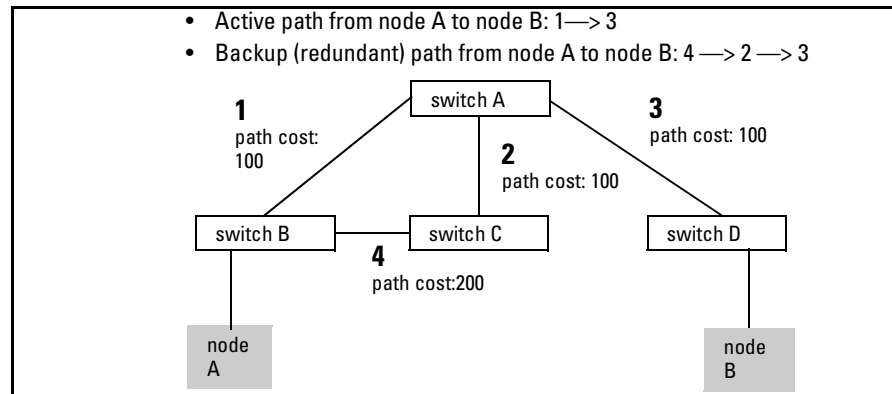

**Figure 13-1. General Example of Redundant Paths Between Two Nodes**

In the factory default configuration, spanning tree operation is off. If a redundant link (loop) exists between nodes in your network, you should enable the spanning tree operation of your choice.

---

### Note

Spanning tree retains its current parameter settings when disabled. Thus, if you disable spanning tree, then later re-enable it, the parameter settings will be the same as before spanning tree was disabled.

**Spanning Tree Operation with 802.1Q VLANs.** As recommended in the IEEE 802.1Q VLAN standard, when spanning tree is enabled on the switch, a single spanning tree is configured for all ports across the switch, including those in separate VLANs (that is, single-instance spanning tree, which gener-



ates untagged BPDUs). This means that if redundant physical links exist in separate VLANs, spanning tree will block all but one of those links. However, if you need to use spanning tree on the Series 4100GL switches in a VLAN environment with redundant physical links, you can prevent blocked redundant links by using a port trunk. The following example shows how you can use a port trunk with 802.1Q (tagged) VLANs and spanning tree without unnecessarily blocking any links or losing any bandwidth.

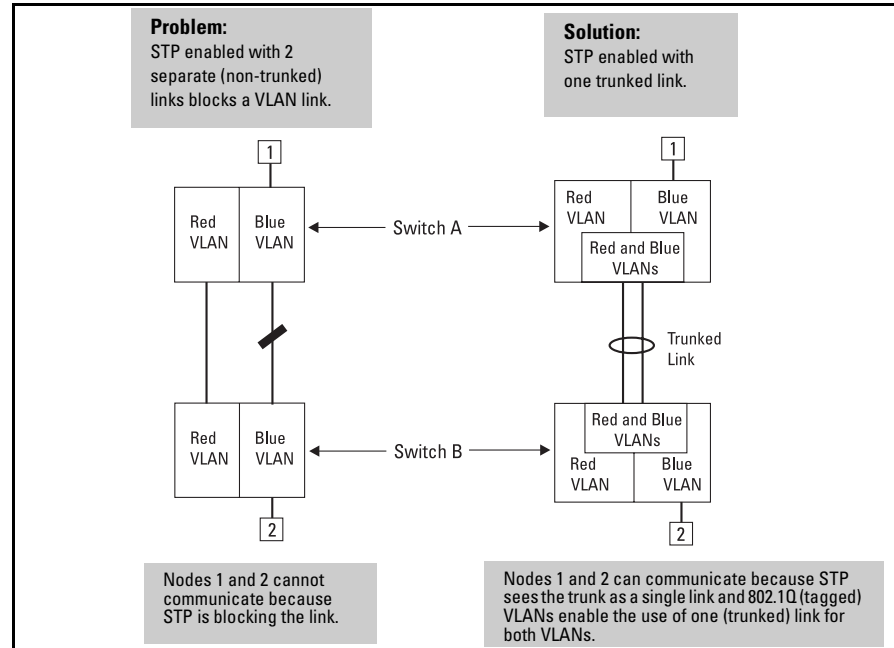

**Figure 13-2. Example of Using a Trunked Link with STP and VLANs**

For more information, refer to “Spanning Tree Operation with VLANs” on page 11-30.

## Spanning Tree Options: RSTP (802.1w) and STP (802.1d)

### RSTP (802.1w)

The IEEE 802.1d version of spanning tree (STP) can take a fairly long time to resolve all the possible paths and to select the most efficient path through the network. The IEEE 802.1w Rapid Reconfiguration Spanning Tree (RSTP) significantly reduces the amount of time it takes to establish the network path. The result is reduced network downtime and improved network robustness.

In addition to faster network reconfiguration, RSTP also implements greater ranges for port path costs to accommodate the higher and higher connection speeds that are being implemented.

RSTP is designed to be compatible with IEEE 802.1d STP, and HP recommends that you employ it in your network. For more information, refer to “Transitioning from STP to RSTP” on page 13-8.

## STP (802.1d)

The IEEE 802.1d version of spanning tree has been in wide use and can coexist in a network in which RSTP (802.1w) has been introduced. If your network currently uses 802.1d STP and you are not yet ready to implement RSTP, you can apply STP to the Series 4100GL switches until such time as you are ready to move ahead with RSTP. STP on the Series 4100GL switches offers the full range of STP features found in earlier product releases, including:

- **STP Fast Mode for Overcoming Server Access Failures:** If an end node is configured to automatically access a server, the duration of the STP startup sequence can result in a “server access failure”. On ports where this is a problem, configuring STP Fast Mode can eliminate the failure. For more information, see “STP Fast Mode” on page 13-26. The next sections describe how to configure STP on the switch. For more information on STP operation, see “How Spanning Tree Operates” on page 13-4.
- **Fast-Uplink STP for Improving the Recovery (Convergence) Time in Wiring Closet Switches with Redundant Uplinks:** This means that a Series 4100GL switch having redundant links toward the root device can decrease the convergence time to a new uplink port to as little as ten seconds. For more information, refer to “Fast-Uplink Spanning Tree Protocol (STP)” on page 13-27.

---

### Caution

---

Because the switch automatically gives faster links a higher priority, the default STP parameter settings are usually adequate for spanning tree operation. Also because incorrect STP settings can adversely affect network performance, you should not make changes unless you have a strong understanding of how STP operates. For more on STP, see the IEEE 802.1D standard.

---

# Configuring Rapid Reconfiguration Spanning Tree (RSTP)

This section describes the operation of the IEEE 802.1w Rapid Spanning Tree Protocol (RSTP)

## Overview

RSTP Feature	Default	Menu	CLI	Web
Viewing the RSTP/STP configuration	<i>n/a</i>	page 13-16	page 13-10	<i>n/a</i>
enable/disable RSTP/STP (RSTP is selected as the default protocol)	disabled	page 13-16	page 13-11	page 13-18
reconfiguring whole-switch values	ProtocolVersion: RSTP Force Version: RSTP-operation Switch Priority: 8 Hello Time: 2 s Max Age: 20 s Forward Delay: 15 s	page 13-16	page 13-12	<i>n/a</i>
reconfiguring per-port values	Path Cost: <i>depends on port type</i> Priority: 8 Edge Port: Yes Point-to-point: Force-true MCheck: Yes	page 13-16	page 13-14	<i>n/a</i>

As indicated in the manual, the spanning tree protocol is used to ensure that only one active path at a time exists between any two end nodes in the network in which your switch is installed. Multiple paths cause a loop in the network over which broadcast and multicast messages are repeated continuously, which floods the network with traffic creating a broadcast storm.

In networks where there is more than one physical path between any two nodes, enabling spanning tree ensures a single active path between two such nodes by selecting the one most efficient path and blocking the other redundant paths. If a switch or bridge in the path becomes disabled, spanning tree activates the necessary blocked segments to create the next most efficient path.

## Transitioning from STP to RSTP

IEEE 802.1w RSTP is designed to be compatible with IEEE 802.1d STP. Even if all the other devices in your network are using STP, you can enable RSTP on your switch, and even using the default configuration values, your switch will interoperate effectively with the STP devices. If any of the switch ports are connected to switches or bridges on your network that do not support RSTP, RSTP can still be used on this switch. RSTP automatically detects when the switch ports are connected to non-RSTP devices in the spanning tree and communicates with those devices using 802.1d STP BPDU packets.

Because RSTP is so much more efficient at establishing the network path, though, that it is highly recommended that all your network devices be updated to support RSTP. RSTP offers convergence times of less than one second under optimal circumstances. To make the best use of RSTP and achieve the fastest possible convergence times, though, there are some changes that you should make to the RSTP default configuration. See “Optimizing the RSTP Configuration” below, for more information on these changes.

---

### Note

Under some circumstances, it is possible for the rapid state transitions employed by RSTP to result in an increase in the rates of frame duplication and misordering in the switched LAN. In order to allow RSTP switches to support applications and protocols that may be sensitive to frame duplication and misordering, setting the Force Protocol Version parameter to **STP-compatible** allows RSTP to be operated with the rapid transitions disabled. The value of this parameter applies to all ports on the switch. See information on Force Version on page 13-12.

---

As indicated above, one of the benefits of RSTP is the implementation of a larger range of port path costs, which accommodates higher network speeds. New default values have also been implemented for the path costs associated with the different network speeds. This can create some incompatibility between devices running the older 802.1d STP and your switch running RSTP. Please see the “Note on Path Cost” on page 13-15 for more information on adjusting to this incompatibility.

## Configuring RSTP

The default switch configuration has spanning tree disabled with RSTP as the selected protocol. That is, when spanning tree is enabled, RSTP is the version of spanning tree that is enabled, by default.

### Optimizing the RSTP Configuration

To optimize the RSTP configuration on your switch, follow these steps (note that for the **Menu** method, all of these steps can be performed at the same time by making all the necessary edits on the “Spanning Tree Operation” screen and then saving the configuration changes):

1. Set the switch to support RSTP (RSTP is the default):

**CLI:** spanning-tree protocol-version rstp

**Menu:** Main Menu → 2. Switch Configuration → 4. Spanning Tree Operation → select Protocol Version: RSTP

2. Set the “point-to-point-mac” value to false on all ports that are connected to shared LAN segments (that is, to connections to hubs):

**CLI:** spanning-tree [ethernet] <port-list> point-to-point-mac force-false

**Menu:** Main Menu → 2. Switch Configuration → 4. Spanning Tree Operation → for each appropriate port, select Point-to-Point: Force-False

3. Set the “edge-port” value to false for all ports connected to other switches, bridges, and hubs:

**CLI:** no spanning-tree [ethernet] <port-list> edge-port

**Menu:** Main Menu → 2. Switch Configuration → 4. Spanning Tree Operation → for each appropriate port, select Edge: No

4. Set the “mcheck” value to false for all ports that are connected to devices that are known to be running IEEE 802.1d spanning tree:

**CLI:** no spanning-tree [ethernet] <port-list> mcheck

**Menu:** Main Menu → 2. Switch Configuration → 4. Spanning Tree Operation → for each appropriate port, select MCheck: No

5. Enable RSTP Spanning Tree:

**CLI:** spanning-tree

**Menu:** Main Menu → 2. Switch Configuration → 4. Spanning Tree Operation → select STP Enabled: Yes

## CLI: Configuring RSTP

Spanning Tree Commands in This Section	Applicable Protocol Version	Location
show spanning-tree config	both	Below on this page
spanning-tree	both	page 13-11
protocol-version <rstp   stp>	both	page 13-12
force-version <rstp-operation   stp-compatible>	RSTP	page 13-12
forward-delay <4 - 30>	both	page 13-12
hello-time <1 - 10>	both	page 13-12
maximum-age <6 - 40>	both	page 13-12
priority <0 - 15   0 - 65535>	RSTP   STP	page 13-12
<[ethernet] port-list>	both	page 13-14
path-cost <1 - 200 000 000>	both	page 13-14
priority <0 - 15   0 - 65535>	RSTP   STP	page 13-14
edge-port	RSTP	page 13-14
point-to-point-mac	RSTP	page 13-14
mcheck	RSTP	page 13-14
mode <norm   fast>	STP	Refer to “802.1p Spanning-Tree Protocol (STP)” on page 13-19.
show spanning-tree	This command lists additional RSTP/STP monitoring data that is not covered in this section. See “Spanning Tree Protocol Information” in Chapter B, “Monitoring and Analyzing Switch Operation”	

**Viewing the Current Spanning Tree Configuration.** Even if spanning tree is disabled (the default configuration), the show spanning-tree config command lists the switch’s full spanning tree configuration, including whole-switch and per-port settings.

**Syntax:** show spanning-tree configuration

**Abbreviation:** sho span config

In the default configuration, the output from this command appears similar to the following:

```
Spanning Tree Operation

Protocol Version : RSTP
STP Enabled [No] : Yes
Force Version [RSTP-operation] : RSTP-operation
Switch Priority [8] : 8           Hello Time [2] : 2
Max Age [20] : 20                Forward Delay [15] : 15

Port Type      | Cost      Priority Edge Point-to-Point MCheck
-----+-----
A1  10/100TX | 200000    8       Yes Force-True   Yes
A2  10/100TX | 200000    8       Yes Force-True   Yes
A3  10/100TX | 200000    8       Yes Force-True   Yes
A4  10/100TX | 200000    8       Yes Force-True   Yes
A5  10/100TX | 200000    8       Yes Force-True   Yes
A6  10/100TX | 200000    8       Yes Force-True   Yes
A7  10/100TX | 200000    8       Yes Force-True   Yes
A8  10/100TX | 200000    8       Yes Force-True   Yes
A9  10/100TX | 200000    8       Yes Force-True   Yes
A10 10/100TX | 200000    8       Yes Force-True   Yes
A11 10/100TX | 200000    8       Yes Force-True   Yes
A12 10/100TX | 200000    8       Yes Force-True   Yes
-- MORE --, next page: Space, next line: Enter, quit: Control-C
```

Figure 13-3. Example of the Spanning Tree Configuration Display

**Enabling or Disabling RSTP.** Issuing the command to enable spanning tree on the switch implements, by default, the RSTP version of spanning tree for all physical ports on the switch. Disabling spanning tree removes protection against redundant network paths.

**Syntax:** [no] spanning-tree

**Abbreviation:** [no] span

This command enables spanning tree with the current parameter settings or disables spanning tree, using the “no” option, without losing the most-recently configured parameter settings.

**Enabling STP Instead of RSTP.** If you decide, for whatever reason, that you would prefer to run the IEEE 802.1d (STP) version of spanning tree, then issue the following command:

**Syntax:** spanning-tree protocol-version stp

**Abbreviation:** span prot stp

**802.1w Rapid Spanning Tree Protocol (RSTP) and 802.1d Spanning Tree Protocol (STP)**  
Configuring Rapid Reconfiguration Spanning Tree (RSTP)

For the STP version of spanning tree, the rest of the information in this section does not apply. Refer to “802.1p Spanning-Tree Protocol (STP)” on page 13-19 for more information on the STP version and its parameters.

**Reconfiguring Whole-Switch Spanning Tree Values.** You can configure one or more of the following parameters, which affect the spanning tree operation of the whole switch:

**Table 13-1. Whole-Switch RSTP Parameters**

Parameter	Default	Description
protocol-version	RSTP	Identifies which of the spanning tree protocols will be used when spanning tree is enabled on the switch.
force-version	rstp-operation	Sets the spanning tree compatibility mode. Even if <b>rstp-operation</b> is selected though, if the switch detects STP BPDU packets on a port, it will communicate to the attached device using STP BPDU packets. If errors are encountered, as described in the Note on page 8, the Force-Version value can be set to <b>stp-compatible</b> , which forces the switch to communicate out all ports using operations that are compatible with IEEE 802.1d STP.
priority	32768 (8 as a step value)	Specifies the protocol value used along with the switch MAC address to determine which device in the spanning tree is the root. The lower the priority value, the higher the priority. The value you enter has changed from the STP value. The range is 0 - 61440, but for RSTP the value is entered as a multiple (a step) of 4096. You enter a value in the range 0 - 15. The default value of 32768 is derived by the default setting of 8. Displaying the RSTP configuration ( <b>show spanning-tree config</b> ) shows 8, but displaying the RSTP operation ( <b>show spanning-tree</b> ) shows 32768.
*maximum-age	20 seconds	Sets the maximum age of received spanning tree information before it is discarded. The range is 6 to 40 seconds.
*hello-time	2 seconds	Sets the time between transmission of spanning tree messages. Used only when this switch is the root. The range is 1 to 10 seconds.
*forward-delay	15 seconds	Sets the time the switch waits between transitioning ports from listening to learning and from learning to forwarding states. The range is 4 to 30 seconds.

\*These parameters are the same for RSTP as they are for STP. The switch uses its own maximum-age, hello-time, and forward-delay settings only if it is operating as the root device in the spanning tree. If another device is the root device, then the switch uses the other device's settings for these parameters.



---

**Note**

Executing the **spanning-tree** command alone enables spanning tree. Executing the command with one or more of the whole-switch RSTP parameters shown in the table on the previous page, or with any of the per-port RSTP parameters shown in the table on page 14, does not enable spanning tree. It only configures the spanning tree parameters, regardless of whether spanning tree is actually running (enabled) on the switch.

Using this facility, you can completely configure spanning tree the way you want and then enable it. This method minimizes the impact on the network operation.

---

***Syntax:***

```
spanning-tree
  protocol-version <rstp | stp>
  force-version <rstp-operation | stp-compatible>
  priority <0 - 15>
  maximum-age <6 - 40 seconds>
  hello-time <1- 10 seconds>
  forward-delay <4 - 30 seconds>
```

***Abbreviations:***

```
span
  prot <rstp | stp>
  forc <rstp | stp>
  pri <0 - 15>
  max <6 - 40>
  hello <1 - 10>
  forw <4 - 30>
```

***Defaults:*** see the table on the previous page.

Multiple parameters can be included on the same command line. For example, to configure a maximum-age of 30 seconds and a hello-time of 3 seconds, you would issue the following command:

```
HPswitch (config)# span max 30 hello 3
```

**Reconfiguring Per-Port Spanning Tree Values.** You can configure one or more of the following parameters, which affect the spanning tree operation of the specified ports only:

**Table 13-2.Per-Port RSTP Parameters**

Parameter	Default	Description
edge-port	Yes	Identifies ports that are connected to end nodes. During spanning tree establishment, these ports transition immediately to the Forwarding state. In this way, the ports operate very similarly to ports that are configured in “fast mode” under the STP implementation in previous HP switch software. Disable this feature on all switch ports that are connected to another switch, or bridge, or hub. Use the “no” option on the spanning tree command to disable edge-port.
mcheck	Yes	Ports with mcheck set to true are forced to send out RSTP BPDUs for 3 seconds. This allows for switches that are running RSTP to establish their connection quickly and for switches running 802.1d STP to be identified. If the whole-switch parameter Force-Version is set to “stp-compatible”, the mcheck setting is ignored and STP BPDUs are sent out all ports. Disable this feature on all ports that are known to be connected to devices that are running 802.1d STP. Use the “no” option on the spanning tree command to disable mcheck.
path-cost	10 Mbps – 2 000 000 100 Mbps – 200 000 1 Gbps – 20 000	Assigns an individual port cost that the switch uses to determine which ports are the forwarding ports. The range is 1 to 200,000,000 or auto. By default, this parameter is automatically determined by the port type, as shown by the different default values. If you have previously configured a specific value for this parameter, you can issue the command with the <b>auto</b> option to restore the automatic setting feature. Please see the Note on Path Cost on page 13-15 for information on compatibility with devices running 802.1d STP for the path cost values.
point-to-point-mac	force-true	This parameter is used to tell the port if it is connected to a point-to-point link, such as to another switch or bridge or to an end node ( <b>force-true</b> ). This parameter should be set to <b>force-false</b> for all ports that are connected to a hub, which is a shared LAN segment. You can also set this parameter to <b>auto</b> and the switch will automatically set the force-false value on all ports that it detects are not running at full duplex. All connections to hubs are not full duplex.
priority	128 (8 as a step value)	This parameter is used by RSTP to determine the port(s) to use for forwarding. The port with the lowest number has the highest priority. The range is 0 to 240, but you configure the value by entering a multiple of 16. You enter a value in the range 0 - 15. The default value of 128 is derived by the default setting of 8. Displaying the RSTP configuration ( <b>show spanning-tree config</b> ) shows 8, but displaying the RSTP operation ( <b>show spanning-tree</b> ) shows 128.

<b>Syntax:</b>	<b>Abbreviations:</b>
spanning-tree [ethernet] <port-list> path-cost <1 - 200000000> point-to-point-mac <force-true   force-false   auto> priority <0 - 15>	span <port-list> path <1 - 200000000> forc <force-t   force-f   auto> pri <0 - 15>
[no] spanning-tree [ethernet] <port-list> edge-port mcheck	[no] span <port-list> edge mch

**Defaults:** see the table on the previous page.

---

### Note on Path Cost

RSTP implements a greater range of path costs and new default path cost values to account for higher network speeds. These values are different than the values defined by 802.1d STP as shown below.

Port Type	802.1d STP Path Cost	RSTP Path Cost
10 Mbps	100	2 000 000
100 Mbps	10	200 000
1 Gbps	5	20 000
10 Gbps	?	2000

Because the maximum value for the path cost allowed by 802.1d STP is 65535, devices running that version of spanning tree cannot be configured to match the values defined by RSTP, at least for 10 Mbps and 100 Mbps ports. In LANs where there is a mix of devices running 802.1d STP and RSTP, you should reconfigure the devices so the path costs match for ports with the same network speeds.

---

## Menu: Configuring RSTP

1. From the console CLI prompt, enter the menu command.  
HP Procurve Switch # **menu**
2. From the switch console Main Menu, select  
**2. Switch Configuration ...**  
**4. Spanning Tree Operation**
3. Press **E** (for **Edit**) to highlight the **Protocol Version** parameter field.
4. Press the Space bar to select the version of spanning tree you wish to run:  
**RSTP** or **STP**.  
**Note:** If you change the protocol version, you will have to reboot the switch for the change to take effect. See step 9 and step 10.
5. Press the **Tab** or down arrow key to go to the **STP Enabled** field. Note that when you do this, the remaining fields on the screen will then be appropriate for the version of spanning tree that was selected in step 3. The screen image below is for RSTP.
6. Press the Space bar to select **Yes** to enable spanning tree.

```

----- TELNET - MANAGER MODE -----
                Switch Configuration - Spanning Tree Operation

Protocol Version : RSTP
STP Enabled [No] : No
Force Version [RSTP-operation] : RSTP-operation
Switch Priority [8] : 8                Hello Time [2] : 2
Max Age [20] : 20                    Forward Delay [15] : 15

Port    Type      Cost    Priority  Edge  Point-to-Point  MCheck
-----+-----
A1     10/100TX | 200000    8      Yes   Force-True      Yes
A2     10/100TX | 200000    8      Yes   Force-True      Yes
A3     10/100TX | 200000    8      Yes   Force-True      Yes
A4     10/100TX | 200000    8      Yes   Force-True      Yes
A5     10/100TX | 200000    8      Yes   Force-True      Yes
A6     10/100TX | 200000    8      Yes   Force-True      Yes

Actions->  Cancel   Edit    Save    Help

Cancel changes and return to previous screen.
Use arrow keys to change action selection and <Enter> to execute action.

```

Figure 13-4. Example of the RSTP Configuration Screen

7. Press the **[Tab]** key or use the arrow keys to go to the next parameter you want to change, then type in the new value or press the Space bar to select a value. (To get help on this screen, press **[Enter]** to select the **Actions->** line, then press **[H]**, for **Help**, to display the online help.)
8. Repeat step 6 for each additional parameter you want to change.  
Please see “Optimizing the RSTP Configuration” on page 13-9 for recommendations on configuring RSTP to make it operate the most efficiently.
9. When you are finished editing parameters, press **[Enter]** to return to the **Actions->** line and press **[S]** to save the currently displayed spanning tree settings and return to the Main Menu.
10. If you have changed the Protocol Version, in step 1, reboot the switch now by selecting

### 6. Reboot Switch

## Web: Enabling or Disabling RSTP

In the web browser interface, you can enable or disable spanning tree on the switch. If the default configuration is in effect such that RSTP is the selected protocol version, enabling spanning tree through the web browser interface will enable RSTP with its current configuration. To configure the other spanning tree features, telnet to the switch console and use the CLI or menu.

To enable or disable spanning tree using the web browser interface:

1. Click on the **Configuration** tab.
2. Click on [Device Features](#).
3. Enable or disable spanning tree.
4. Click on [Apply Changes](#) to implement the configuration change.

## 802.1p Spanning-Tree Protocol (STP)

### Menu: Configuring 802.1D STP

1. From the Main Menu, select:
  2. **Switch Configuration . . .**
  4. **Spanning Tree Operation**

```
----- CONSOLE - MANAGER MODE -----
Switch Configuration - Spanning Tree Operation

Protocol Version : RSTP ← Use this field to select the 802.1d version of STP.
STP Enabled [No] : No
Force Version [RSTP-operation] : RSTP-operation
Switch Priority [8] : 8           Hello Time [2] : 2
Max Age [20] : 20                Forward Delay [15] : 15

Port      Type      Cost      Priority  Edge  Point-to-Point  MCheck
-----
A1      10/100TX  200000    8         Yes   Force-True      Yes
A2      10/100TX  200000    8         Yes   Force-True      Yes
A3      10/100TX  200000    8         Yes   Force-True      Yes
A4      10/100TX  200000    8         Yes   Force-True      Yes
A5      10/100TX  200000    8         Yes   Force-True      Yes
A6      10/100TX  200000    8         Yes   Force-True      Yes

Actions->  Cancel   Edit   Save   Help

Cancel changes and return to previous screen.
Use arrow keys to change action selection and <Enter> to execute action.
```

**Figure 13-5. The Default “Spanning Tree Operation” Screen**

2. Press **[E]** (for **Edit**) to highlight the **Protocol Version** field. In the default configuration this field is set to **RSTP**.
3. Press the Space bar once to change the field to STP. This changes the Protocol Version selection to the 802.1d Spanning Tree Protocol.
4. Press **[↓]** to highlight the **STP Enabled** field.
5. Press the Space bar to select **Yes**. (**Yes** in this field means to enable spanning-tree operation.)

802.1w Rapid Spanning Tree Protocol (RSTP) and 802.1d Spanning Tree Protocol (STP)  
802.1p Spanning-Tree Protocol (STP)

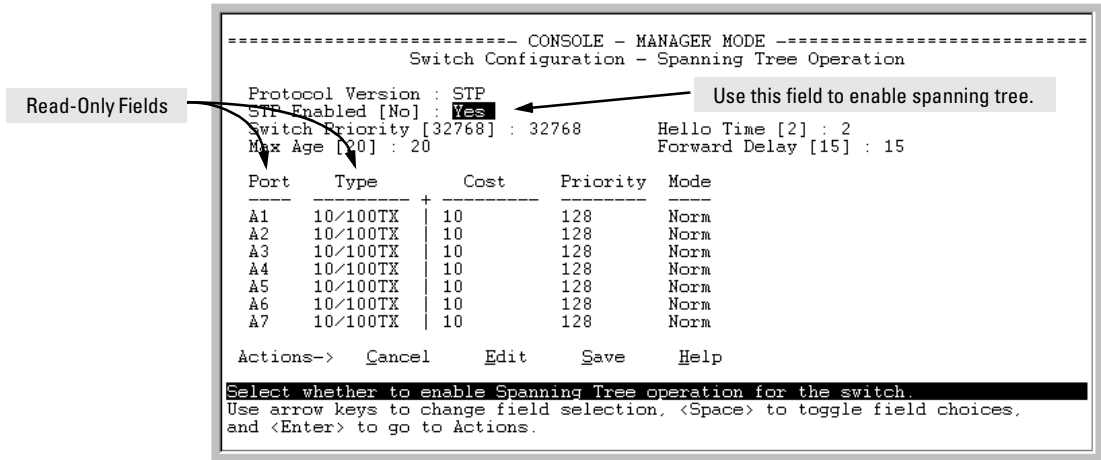

**Figure 13-6. Enabling Spanning-Tree Operation**

6. If the remaining STP parameter settings are adequate for your network, go to step 10.
7. Use **[Tab]** or the arrow keys to select the next parameter you want to change, then type in the new value or press the Space Bar to select a value. (If you need information on STP parameters, press **[Enter]** to select the **Actions** line, then press **H** to get help.)
8. Repeat step 7 for each additional parameter you want to change.  
**Note:** For information on the **Mode** parameter, see “STP Fast Mode” on page 13-26.
9. When you are finished editing parameters, press **[Enter]** to return to the **Actions** line.
10. Press **[S]** to save the currently displayed STP parameter settings. You will then see the “Switch Configuration Menu” with an asterisk (\*) at the **Spanning Tree Operation** line, indicating that you must reboot the switch before the Protocol Version change (step 5) takes effect.



```
----- CONSOLE - MANAGER MODE -----  
Switch Configuration Menu  
  
1. System Information  
2. Port/Trunk Settings  
3. Network Monitoring Port  
*4. Spanning Tree Operation  
5. IP Configuration  
6. SNMP Community Names  
7. IP Authorized Managers  
8. VLAN Menu...  
0. Return to Main Menu...  
  
Configures the switch and port Spanning Tree parameters.  
To select menu item, press item number, or highlight item and press <Enter>.  
(*Needs reboot to activate changes.)
```

**Figure 13-7. The Configuration Menu Indicating a Reboot Is Needed to Implement a Configuration Change**

11. Press **0** to return to the Main menu.

```
----- CONSOLE - MANAGER MODE -----  
Main Menu  
  
1. Status and Counters...  
*2. Switch Configuration...  
3. Console Passwords...  
4. Event Log  
5. Command Line (CLI)  
6. Reboot Switch  
7. Download OS  
8. Run Setup  
9. Stacking...  
0. Logout  
  
Displays the menu for customizing the switch configuration.  
To select menu item, press item number, or highlight item and press <Enter>.  
(*Needs reboot to activate changes.)
```

**Figure 13-8. The Main Menu Indicating a Reboot Is Needed To Implement a Configuration Change**

12. Press **6** to reboot the switch. This implements the Protocol Version change (steps 2 and 3 on page 13-19).

## CLI: Configuring 802.1D STP

### STP Commands Used in This Section

---

show spanning-tree config	Below
spanning-tree	
protocol-version	page 13-23
forward-delay <4 - 30>	page 13-24
hello-time <1 - 10>	page 13-24
maximum-age <6 - 40>	page 13-24
priority <0 - 65535>	page 13-24
ethernet <port-list>	page 13-25
path-cost <1 - 65535>	page 13-25
priority <0 - 255>	page 13-25
mode <norm / fast>	page 13-25
show spanning tree	Lists additional STP data not covered in this chapter. See "Spanning Tree Protocol (STP) Information" on page B-17

---

**Viewing the Current STP Configuration.** Regardless of whether STP is disabled (the default), this command lists the switch's full STP configuration, including general settings and port settings.

**Syntax:** show spanning-tree config

When the switch is configured for 802.1d STP, this command displays information similar to the following:

```
HPswitch(config)# show spanning-tree config
Spanning Tree Operation

Protocol Version : STP
STP Enabled [No] : No
Switch Priority [32768] : 32768
Max Age [20] : 20
Hello Time [2] : 2
Forward Delay [15] : 15

Port Type | Cost | Priority | Mode
-----+-----+-----+-----
A1 10/100TX | 10 | 128 | Norm
A2 10/100TX | 10 | 128 | Norm
A3 10/100TX | 10 | 128 | Norm
A4 10/100TX | 10 | 128 | Norm
A5 10/100TX | 10 | 128 | Norm
. . . . .
. . . . .
. . . . .
```

Command Listing when STP is the Protocol Version (See also page 13-10)

**Figure 13-9. Example of the Default STP Configuration Listing with 802.1d STP Configured at the Protocol Version**

**Configuring the Switch To Use the 802.1d Spanning Tree Protocol (STP).** In the default configuration, the switch is set to **RSTP** (that is, 802.1w Rapid Spanning Tree), and spanning tree operation is disabled. To reconfigure the switch to 802.1d spanning tree, you must:

1. Change the spanning tree protocol version to **stp**.
2. Use **write memory** to save the change to the startup-configuration.
3. Reboot the switch.
4. If you have not previously enabled spanning-tree operation on the switch, use the **spanning-tree** command again to enable STP operation.

**Syntax:** spanning-tree protocol-version stp  
write memory  
boot

For example:

```
HPswitch(config)# spanning-tree protocol-version stp
STP version was changed. To activate the change you must
save the configuration to flash and reboot the device.
HPswitch(config)# write memory
HPswitch(config)# boot
Device will be rebooted, do you want to continue [y/n]? y
Rebooting the System
```

**Figure 13-10. Steps for Changing Spanning-Tree Operation to the 802.1d Protocol**

### **Enabling (or Disabling) Spanning Tree Operation on the Switch.**

This command enables (or disables) spanning tree operation for either spanning tree version—STP/802.1d or RSTP/802.1w (the default). Before using this command, ensure that the version of spanning tree you want to use is active on the switch. (See the preceding topic, “Configuring the Switch To Use the 802.1d Spanning Tree Protocol (STP)” on page 13-23.)

**Syntax:** [ no ] spanning-tree

**Default:** Disabled

For example:

```
HPswitch spanning-tree
```

Enabling STP implements the spanning tree protocol for all physical ports on the switch, regardless of whether multiple VLANs are configured. Disabling STP removes protection against redundant loops that can significantly slow or halt a network.

This command enables STP with the current parameter settings or disables STP without losing the most-recently configured parameter settings. (To learn how the switch handles parameter changes, how to test changes without losing the previous settings, and how to replace previous settings with new settings, see Chapter 5, “Switch Memory and Configuration”.) When enabling STP, you can also include the STP general and per-port parameters described in the next two sections. When you use the “no” form of the command, you can do so only to disable STP. (STP parameter settings are not changed when you disable STP.)

---

**Caution**

---

Because incorrect STP settings can adversely affect network performance, HP recommends that you use the default STP parameter settings. You should not change these settings unless you have a strong understanding of how STP operates. For more on STP, see the IEEE 802.1d standard.

**Reconfiguring General STP Operation on the Switch.** You can configure one or more of the following parameters:

**Table 13-3. General STP Operating Parameters**

Name	Default	Range	Function
priority	32768	0 - 65535	Specifies the priority value used along with the switch MAC address to determine which device is root. The lower a priority value, the higher the priority.
*maximum-age	20 seconds	6 - 40 seconds	Maximum received message age the switch allows for STP information before discarding the message.
*hello-time	2 seconds	1 - 10	Time between messages transmitted when the switch is the root.
*forward-delay	15 seconds	4 - 30 seconds	Time the switch waits before transitioning from the listening to the learning state, and between the learning state to the forwarding state.

---

\*The switch uses its own maximum-age, hello-time, and forward-delay settings only if it is operating as the root device. If another device is operating as the root device, then the switch uses the other device's settings for these parameters.

---

---

**Note**

---

Executing **spanning-tree** alone enables STP. Executing **spanning-tree** with one or more of the above “STP Operating Parameters” does not enable STP. It only configures the STP parameters (regardless of whether STP is actually running (enabled) on the switch).

**Syntax:** spanning-tree  
                   priority <0 - 65355>  
                   maximum-age <6 - 40 seconds>  
                   hello-time <1 - 10 seconds>  
                   forward-delay <4 - 30 seconds>

**Default:** See table 13-3 on page 13-24.

For example, to configure a **maximum-age** of 30 seconds and a **hello-time** of 3 seconds for STP:

```
HPswitch(config)# spanning-tree maximum-age 30 hello-time 3
```

**Reconfiguring Per-Port STP Operation on the Switch.** This command enables STP (if not already enabled) and configures the following per-port parameters:

**Table 13-4. Per-Port STP Parameters**

Name	Default	Range	Function
path-cost	Ethernet: 100 10/100Tx: 10 100 Fx: 10 Gigabit: 5	1 - 65355	Assigns an individual port cost that the switch uses to determine which ports are the forwarding ports.
priority	128	0 - 255	Used by STP to determine the port(s) to use for forwarding. The port with the lowest number has the highest priority.
mode	norm	norm - or - fast - or - uplink	Specifies whether a port progresses through the listening, learning, and forwarding (or blocking) states (“norm” mode) or transitions directly to the forwarding state (“fast” mode). <ul style="list-style-type: none"> <li>• For information on when to use Fast mode, see “STP Fast Mode” on page 13-26.)</li> <li>• For information on Uplink mode, see “Fast-Uplink Spanning Tree Protocol (STP)” on page 13-27</li> </ul>

You can also include STP general parameters in this command. See “Reconfiguring General STP Operation on the Switch” on page 13-24.

**Syntax:** spanning-tree [ethernet] <port-list>  
          path-cost <1 - 65535>  
          priority <0 - 255>  
          mode <norm / fast>

**Default:** See table 13-4 on page 13-25.

For example, the following configures ports C5 and C6 to a path cost of **15**, a priority of **100**, and **fast** mode:

```
HPswitch(config)# spanning-tree c5-c6 path-cost 15  
                  priority 100 mode fast
```

## STP Fast Mode

For standard STP operation, when a network connection is established on a device that is running STP, the port used for the connection goes through a sequence of states (Listening and Learning) before getting to its final state (Forwarding or Blocking, as determined by the STP negotiation). This sequence takes two times the forward delay value configured for the switch. The default is 15 seconds on HP switches, per the IEEE 802.1D standard recommendation, resulting in a total STP negotiation time of 30 seconds. Each switch port goes through this start-up sequence whenever the network connection is established on the port. This includes, for example, when the switch or connected device is powered up, or the network cable is connected.

A problem can arise from this long STP start-up sequence because some end nodes are configured to automatically try to access a network server whenever the end node detects a network connection. Typical server access includes to Novell servers, DHCP servers, and X terminal servers. If the server access is attempted during the time that the switch port is negotiating its STP state, the server access will fail. To provide support for this end node behavior, the Series 4100GL switches offers a configuration mode, called “Fast Mode”, that causes the switch port to skip the standard STP start-up sequence and put the port directly into the “Forwarding” state, thus allowing the server access request to be forwarded when the end node needs it.

If you encounter end nodes that repeatedly indicate server access failure when attempting to bring up their network connection, and you have enabled STP on the switch, try changing the configuration of the switch ports associated with those end nodes to STP Fast Mode.

---

**Caution**

The Fast Mode configuration should be used only on switch ports connected to end nodes. Changing the Mode to Fast on ports connected to hubs, switches, or routers may cause loops in your network that STP may not be able to immediately detect, in all cases. This will cause temporary loops in your network. After the fast start-up sequence, though, the switch ports operate according to the STP standard, and will adjust their state to eliminate continuing network loops.

**To Enable or Disable Fast Mode for a Switch Port:**

You can use either the CLI or the menu interface to toggle between STP Fast mode and STP Normal mode. (To use the menu interface, see “Menu: Configuring 802.1D STP” on page 13-19.)

**Syntax:** spanning-tree <port list> mode <fast | norm>

For example, to configure Fast mode for ports C1-C3 and C5:

```
HPswitch(config)# spanning-tree c1-c3,c5 mode fast
```

## Fast-Uplink Spanning Tree Protocol (STP)

Fast-Uplink STP is an option added to the switch’s 802.1d STP to improve the recovery (convergence) time in wiring closet switches with redundant uplinks. Specifically, a Series 4100GL switch having redundant links toward the root device can decrease the convergence time (or failover) to a new uplink (STP root) port to as little as ten seconds. To realize this performance, the switch must be:

- Used as a wiring closet switch (also termed an *edge switch* or a *leaf switch*).
- Configured for fast-uplink STP mode on two or more ports intended for redundancy in the direction of the root switch, so that at any time only one of the redundant ports is expected to be in the forwarding state.

---

**Note**

Fast-Uplink STP operates only with 802.1d STP and is not available with the Rapid STP (802.1w) feature (page 13-7).

---

---

**Caution**

In general, fast-uplink spanning tree on the Series 4100GL switches is useful when running STP in a tiered topology that has well-defined edge switches. Also, ensure that an interior switch is used for the root switch and for any logical backup root switches. You can accomplish this by using the Spanning Tree Priority (sometimes termed bridge priority) settings that define the primary STP root switch and at least one failover root switch (in the event that the primary root switch fails). Inappropriate use of Fast-Uplink STP can cause intermittent loops in a network topology. For this reason, the Fast-Uplink STP feature should be used only by experienced network administrators who have a strong understanding of the IEEE 802.1D standard and STP interactions and operation. If you want to learn more about STP operation, you may find it helpful to refer to publications such as:

Perlmán, Radia, *Interconnections, Second Edition; Bridges, Routers, Switches, and Internetworking Protocols*, Addison-Wesley Professional Computing Series, October 1999

---

**Note**

When properly implemented, fast-uplink STP offers a method for achieving faster failover times than standard STP, and is intended for this purpose for instances where 802.1d STP has been chosen over 802.1w RSTP.

To use fast-uplink STP, configure fast-uplink (**Mode = Uplink**) only on the switch's upstream ports; (that is, two or more ports forming a group of redundant links in the direction of the STP root switch). If the active link in this group goes down, fast-uplink STP selects a different upstream port as the root port and resumes moving traffic in as little as ten seconds. The device(s) on the other end of the links must be running STP. However, because fast uplink should be configured only on the Series 4100GL switch uplink ports, the device(s) on the other end of the links can be either HP devices or another vendor's devices, regardless of whether they support fast uplink. For example:

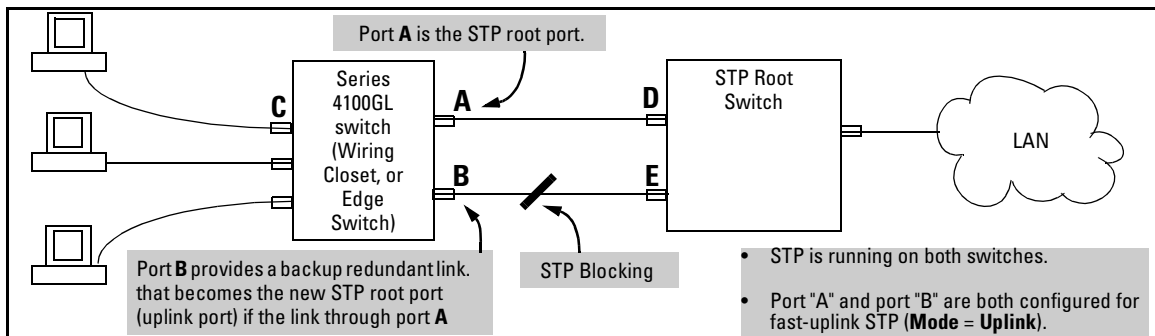

**Figure 13-11. Example of How To Implement Fast-Uplink STP**



## Terminology

Term	Definition
downlink port (downstream port)	A switch port that is linked to a port on another switch (or to an end node) that is sequentially further away from the STP root device. For example, port "C" in figure 13-11, above, is a downlink port.
edge switch	For the purposes of fast-uplink STP, this is a switch that has no other switches connected to its downlink ports. An edge switch is sequentially further from the root device than other switches to which it is connected. Also termed <i>wiring closet switch</i> or <i>leaf switch</i> . For example, switch "4" in figure 13-12 (page 29) is an edge switch.
interior switch	In an STP environment, a switch that is sequentially closer to the STP root device than one or more other switches to which it is connected. For example, switches "1", "2", and "3" in figure 13-12 (page 29) are interior switches.
single-instance spanning tree	A single spanning-tree ensuring that there are no logical network loops associated with any of the connections to the switch, regardless of whether there are any VLANs configured on the switch. For more information, see "Spanning Tree Protocol (STP)" in chapter 9, "Configuring Advanced Features", in the Management and Configuration Guide for your switch.
uplink port (upstream port)	A switch port linked to a port on another switch that is sequentially closer to the STP root device. For example, ports "A" and "B" in figure 13-11 on page 28 are uplink ports.
wiring closet switch	Another term for an "edge" or "leaf" switch.

When single-instance spanning tree (STP) is running in a network and a forwarding port goes down, a blocked port typically requires a period of  $(2 \times (\text{forward delay}) + \text{link down detection})$

to transition to forwarding. In a normal spanning tree environment, this transition is usually 30 seconds (with the **Forward Delay** parameter set to its default of 15 seconds). However, by using the fast-uplink spanning tree feature, a port on a Series 4100GL switch used as an *edge switch* can make this transition in as little as ten seconds. (In an STP environment, an *edge switch* is a switch that is connected only to switches that are closer to the STP root switch than the edge switch itself, as shown by switch "4" in figure 13-12, below.)

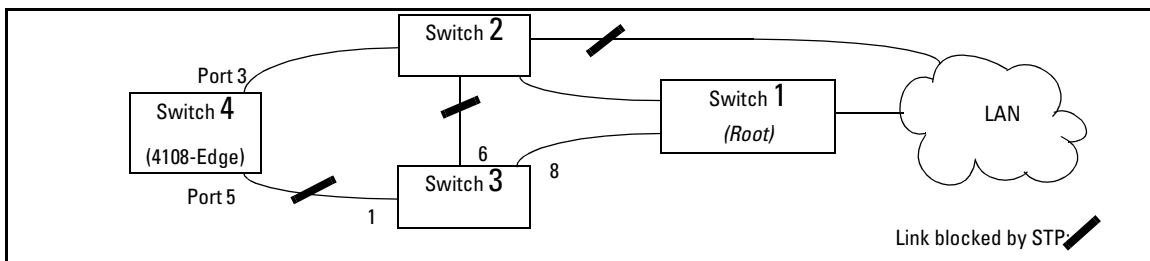

Figure 13-12. Example of an Edge Switch in a Topology Configured for STP Fast Uplink

In figure 13-12, STP is enabled and in its default configuration on all switches, unless otherwise indicated in table 13-5, below:

**Table 13-5. STP Parameter Settings for Figure 13-12**

STP Parameter	Switch "1"	Switch "2"	Switch "3"	Switch "4"
Switch Priority	0 <sup>1</sup>	1 <sup>2</sup>	32,768 (default)	32,768 (default)
(Fast) Uplink	No	No	No	Ports 3 & 5

<sup>1</sup>This setting ensures that Switch "1" will be the primary root switch for STP in figure 13-12.  
<sup>2</sup>This setting ensures that Switch "2" will be the backup root switch for STP in figure 13-12.

With the above-indicated topology and configuration:

- **Scenario 1:** If the link between switches "4" and "2" goes down, then the link between switches "4" and "3" will begin forwarding in as little as ten seconds.
- **Scenario 2:** If Switch "1" fails, then:
  - Switch "2" becomes the root switch.
  - The link between Switch "3" and Switch "2" begins forwarding.
  - The link between Switch "2" and the LAN begins forwarding.

### Operating Rules for Fast Uplink

- A switch with ports configured for fast uplink must be an edge switch and not either an interior switch or the STP root switch.

Configure fast-uplink on only the edge switch ports used for providing redundant STP uplink connections in a network. (Configuring Fast-Uplink STP on ports in interior switches can create network performance problems.) That is, a port configured for STP uplink should not be connected to a switch that is sequentially further away from the STP root device. For example, switch "4" in figure 13-12 (page 13-29) is an edge switch.

- Configure fast uplink on a group (two or more) of redundant edge-switch uplink ports where only one port in the group is expected to be in the forwarding state at any given time.

- Edge switches cannot be directly linked together using fast-uplink ports. For example, the connection between switches 4 and 5 in figure 13-13 is not allowed for fast-uplink operation.

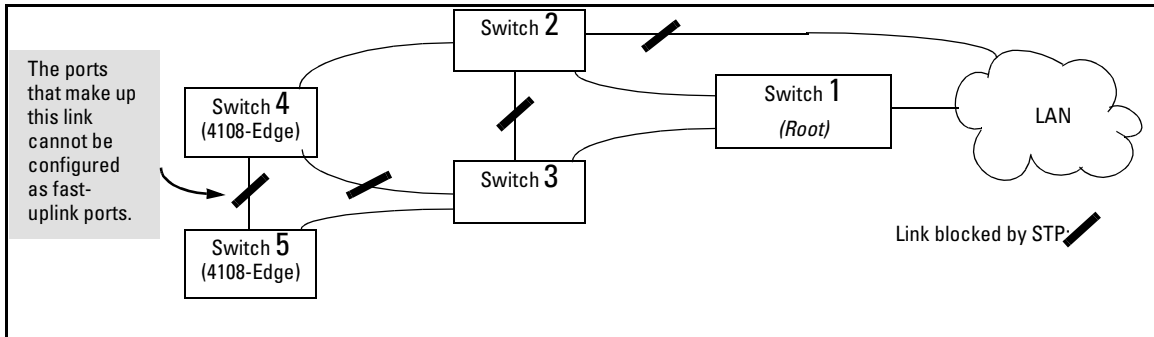

Figure 13-13. Example of a Disallowed Connection Between Edge Switches

- Apply fast-uplink only on the uplink ports of an edge switch. For example, on switch "4" (an edge switch) in figure 13-13 above, only the ports connecting switch "4" to switches "2" and "3" are upstream ports that would use fast uplink. Note also that fast uplink should *not* be configured on both ends of a point-to-point link, but only on the uplink port of an edge switch.
- Ensure that the switch you intend as a backup root device will in fact become the root if the primary root fails, and that no ports on the backup root device are configured for fast-uplink operation. For example, if the **STP Priority** is the same on all switches—default: 32768—then the switch with the lowest MAC address will become the root switch. If that switch fails, then the switch with the next-lowest MAC address will become the root switch. Thus, you can use **STP Priority** to control which switch STP selects as the root switch and which switch will become the root if the first switch fails.
- Fast-Uplink STP requires a minimum of two uplink ports.

## Menu: Viewing and Configuring Fast-Uplink STP

You can use the menu to quickly display the entire STP configuration and to make any STP configuration changes.

**To View and/or Configure Fast-Uplink STP.** This procedure uses the Spanning Tree Operation screen to enable STP and to set the Mode for fast-uplink STP operation.

1. From the Main Menu select:
  2. **Switch Configuration . . .**
  4. **Spanning Tree Operation**
2. In the default STP configuration, RSTP is the selected protocol version. If this is the case on your switch, you must change the Protocol Version to STP in order to use Fast-Uplink STP:

If the **Protocol Version** is set to RSTP (the default, as shown in this example, go to step 3.  
If the **Protocol Version** is set to STP, the rest of the screen will appear as shown in figure 13-16. In this case, go to step 4 on page 13-34.

```
----- CONSOLE - MANAGER MODE -----  
Switch Configuration - Spanning Tree Operation  
  
Protocol Version : RSTP  
STP Enabled [No] : No  
Force Version [RSTP-operation] : RSTP-operation  
Switch Priority [8] : 8           Hello Time [2] : 2  
Max Age [20] : 20                Forward Delay [15] : 15  
  
Port      Type      Cost      Priority  Edge  Point-to-Point  MCheck  
----      -+-----  
A3      10/100TX | 200000    8        Yes   Force-True      Yes  
A4      10/100TX | 200000    8        Yes   Force-True      Yes  
A5      10/100TX | 200000    8        Yes   Force-True      Yes  
A6      10/100TX | 200000    8        Yes   Force-True      Yes  
A7      10/100TX | 200000    8        Yes   Force-True      Yes  
A8      10/100TX | 200000    8        Yes   Force-True      Yes  
  
Actions->  Cancel   Edit   Save   Help  
  
Cancel changes and return to previous screen.  
Use arrow keys to change action selection and <Enter> to execute action.
```

**Figure 13-14. The Default STP Screen With the Protocol Version Field Set to "RSTP"**

3. If the Protocol Version is set to RSTP (as shown in figure 13-14), do the following:
  - a. Press **[E]** (**Edit**) to move the cursor to the **Protocol Version** field.
  - b. Press the Space bar once to change the **Protocol Version** field to STP.
  - c. Press **[Enter]** to return to the command line.
  - d. Press **[S]** (for **Save**) to save the change and exit from the Spanning Tree Operation screen. you will then see a screen with the following:

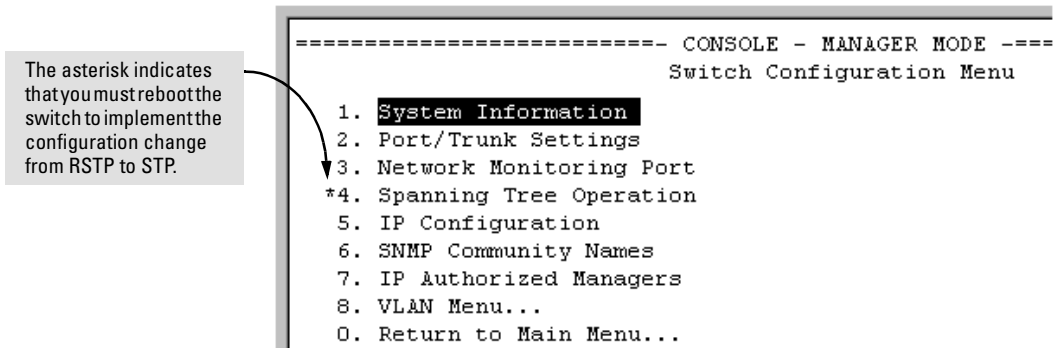

**Figure 13-15. Changing from RSTP to STP Requires a System Reboot**

- e. Press **[0]** (zero) to return to the Main Menu, then **[6]** to reboot the switch.
- f. After you reboot the switch, enter the menu command at the CLI to return to the Main Menu, then select:

**2. Switch Configuration . . .**

**4. Spanning Tree Operation**

You will then see the Spanning Tree screen with **STP** (802.1d) selected in the **Protocol Version** field (figure 13-16).

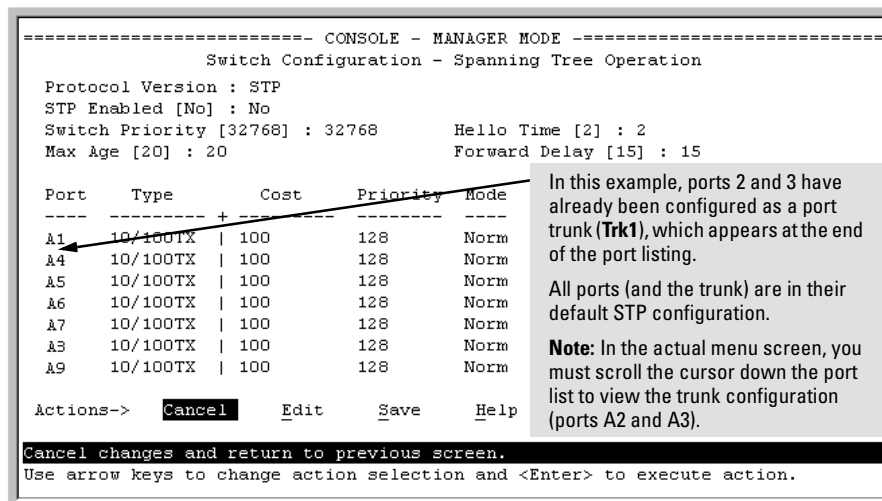

**Figure 13-16. The Spanning Tree Operation Screen**

4. On the ports and/or trunks you want to use for redundant fast uplink connections, change the mode to **Uplink**. In this example, port A1 and Trk1 (using ports A2 and A3) provide the redundant uplinks for STP:
  - a. Press **[E]** (for **Edit**), then enable STP on the switch by using the Space bar to select **Yes** in the Spanning Tree Enabled field.
  - b. Use **[Tab]** to move to the Mode field for port A1.
  - c. Use the Space bar to select **Uplink** as the mode for port A1.
  - d. Use **[↓]** to move to the Mode field for Trk1.
  - e. Use the Space bar to select **Uplink** as the Mode for Trk1.
  - f. Press **[Enter]** to return the cursor to the Actions line.

```

----- CONSOLE - MANAGER MODE -----
Switch Configuration - Spanning Tree Operation

Protocol Version : STP
STP Enabled [No] : No
Switch Priority [32768] : 32768      Hello Time [2] : 2
Max Age [20] : 20                  Forward Delay [15] : 15

Port   Type      Cost   Priority  Mode
-----+-----
A1     10/100TX | 100    128      Uplink
A4     10/100TX | 100    128      Norm
A5     10/100TX | 100    128      Norm
.     .         .     .       .
.     .         .     .       .
A24   10/100TX | 100    128      Norm
Trk1   .         64     .       Uplink

Actions->  Cancel  Edit   Save   Help

Cancel changes and return to previous screen.
Use arrow keys to change action selection and <Enter> to execute action.

```

**Figure 13-17. Example of STP Enabled with Two Redundant Links Configured for Fast-Uplink STP**

5. Press **S** (for **Save**) to save the configuration changes to flash (non-volatile) memory.

**To View Fast-Uplink STP Status.** Continuing from figures 13-16 and 13-17 in the preceding procedure, this task uses the same screen that you would use to view STP status for other operating modes.

1. From the Main Menu, select:
  1. Status and Counters . . .
  7. Spanning Tree Information

**802.1w Rapid Spanning Tree Protocol (RSTP) and 802.1d Spanning Tree Protocol (STP)**  
**802.1p Spanning-Tree Protocol (STP)**

```

=====-- CONSOLE - MANAGER MODE -----
                Status and Counters - Spanning Tree Information
STP Enabled      : Yes
Switch Priority   : 32,768
Hello Time       : 2
Max Age          : 20
Forward Delay    : 15

Topology Change Count : 2
Time Since Last Change : 15 mins

Root MAC Address  : 0060b0-889e00
Root Path Cost   : 20
Root Port        : Trk1
Root Priority     : 16000

Actions->  Back  Show ports  Help

Return to previous screen.
Use arrow keys to change action selection and <Enter> to execute action.
    
```

Indicates which uplink is the active path to the STP root device.  
**Note:** A switch using fast-uplink STP must never be the STP root device.

**Figure 13-18. Example of STP Status with Trk1 (Trunk 1) as the Path to the STP Root Device**

2. Press **[S]** (for **Show ports**) to display the status of individual ports.

```

=====-- CONSOLE - MANAGER MODE -----
                Status and Counters - Spanning Tree - Port Information
Port    Type    Cost  Priority  State    Designated Bridge
-----
A1      10/100TX  10    128     Blocking 0030c1-7fcc40
A4      10/100TX  10    128     Disabled
A5      10/100TX  10    128     Forwarding 0030c1-a914c0
A6      10/100TX  10    128     Forwarding 0030c1-a919c1
.       .         .     .       .
.       .         .     .       .
A24    10/100TX  10    128     Forwarding 0030c1-c884c0
Trk1   Trunk     10    64     Forwarding 0030c1-7fcc40

Actions->  Back  Help

Return to previous screen.
Use up/down arrow keys to scroll to other entries, left/right arrow keys to
change action selection, and <Enter> to execute action.
    
```

Redundant STP Link in (Fast) Uplink Mode

Links to PC or Workstation End Nodes

Redundant STP Link in (Fast) Uplink Mode

**Figure 13-19. Example of STP Port Status with Two Redundant STP Links**



In figure 13-19:

- Port A1 and Trk1 (trunk 1; formed from ports 2 and 3) are redundant fast-uplink STP links, with trunk 1 forwarding (the active link) and port A1 blocking (the backup link). (To view the configuration for port A1 and Trk1, see figure 13-17 on page 13-35.)
- If the link provided by trunk 1 fails (on both ports), then port A1 begins forwarding in fast-uplink STP mode.
- Ports A5, A6, and A24 are connected to end nodes and do not form redundant links.

## CLI: Viewing and Configuring Fast-Uplink STP

**Using the CLI to View Fast-Uplink STP.** You can view fast-uplink STP using the same **show** commands that you would use for standard STP operation:

**Syntax:**

show spanning-tree	Lists STP status.
show spanning-tree config	Lists STP configuration for the switch and for individual ports.

For example, figures 13-20 and 13-21 illustrate a possible topology, STP status listing, and STP configuration for a Series 4100GL switch with:

- STP enabled and the switch operating as an Edge switch
- Port A1 and trunk 1 (Trk1) configured for fast-uplink STP operation
- Several other ports connected to PC or workstation end nodes

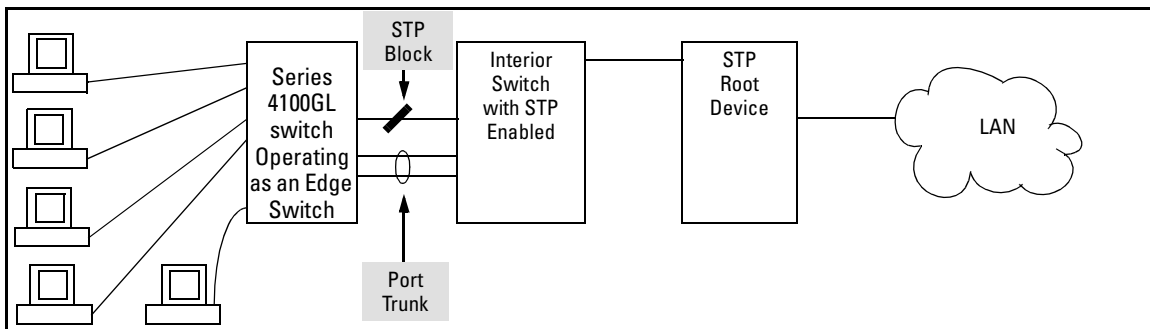

Figure 13-20. Example Topology for the Listing Shown in Figure 13-21

**802.1w Rapid Spanning Tree Protocol (RSTP) and 802.1d Spanning Tree Protocol (STP)  
802.1p Spanning-Tree Protocol (STP)**

```

HPswitch (config)# show spanning-tree
Status and Counters - Spanning Tree Information

STP Enabled           : Yes
Switch Priority       : 32,768
Hello Time           : 2
Max Age              : 20      HPswitch
Forward Delay        : 15

Topology Change Count : 25
Time Since Last Change : 13 mins

Root MAC Address     : 0001e7-a09900
Root Path Cost       : 20
Root Port            : Trk1
Root Priority         : 16768

Port   Type      Cost  Priority  State      | Designated Bridge
-----+-----
A1    10/100TX  10    128     Blocking   | 0030c1-a9c800
A4    10/100TX  10    128     Disabled   |
A5    10/100TX  10    128     Forwarding | 0030c1-7fec40
A6    10/100TX  10    128     Forwarding | 0030c1-a9c800
- MORE --
A7    10/100TX  10    128     Forwarding | 0030c1-a9c822
A8    10/100TX  10    128     Disabled   |
A9    10/100TX  10    128     Forwarding | 00a0c9-a234c3
A10   10/100TX  10    128     Forwarding | 0030c1-449bc0
A11   10/100TX  10    128     Disabled   |
A12   10/100TX  10    128     Disabled   |
Trk1  10/100TX  10    64      Forwarding | 0030c1-a9c800
    
```

Indicates that Trk1 (Trunk 1) provides the currently active path to the STP root device.

Redundant STP link in the Blocking state.

Links to PC or Workstation End Nodes

Redundant STP link in the Forwarding state. (See the "Root Port" field, above. This is the currently active path to the STP root device.)

Indicates that Trk1 (Trunk 1) provides the currently active path to the STP root device.

Redundant STP link in the Blocking state.

Links to PC or Workstation End Nodes

Redundant STP link in the Forwarding state. (See the "Root Port" field, above. This is the currently active path to the STP root device.)

**Figure 13-21. Example of a Show Spanning-Tree Listing for the Topology Shown in Figure 13-20**

```
HPswitch(config)# show spanning-tree config
Spanning Tree Operation
Spanning Tree Enabled : Yes
STP Priority : 32768
Max Age : 20
Hello Time : 2
Forward Delay : 15

Port Type      | Cost  Pri Mode
-----+-----+-----+-----
A1  10/100TX  | 10   128 Uplink
A4  10/100TX  | 10   128 Norm
A5  10/100TX  | 10   128 Norm
A6  10/100TX  | 10   128 Norm
A7  10/100TX  | 10   128 Norm
A8  10/100TX  | 10   128 Norm
A9  10/100TX  | 10   128 Norm
A10 10/100TX  | 10   128 Norm
A11 10/100TX  | 10   128 Norm
A12 10/100TX  | 10   128 Norm
Trk1 Trunk    | 10   64  Uplink
```

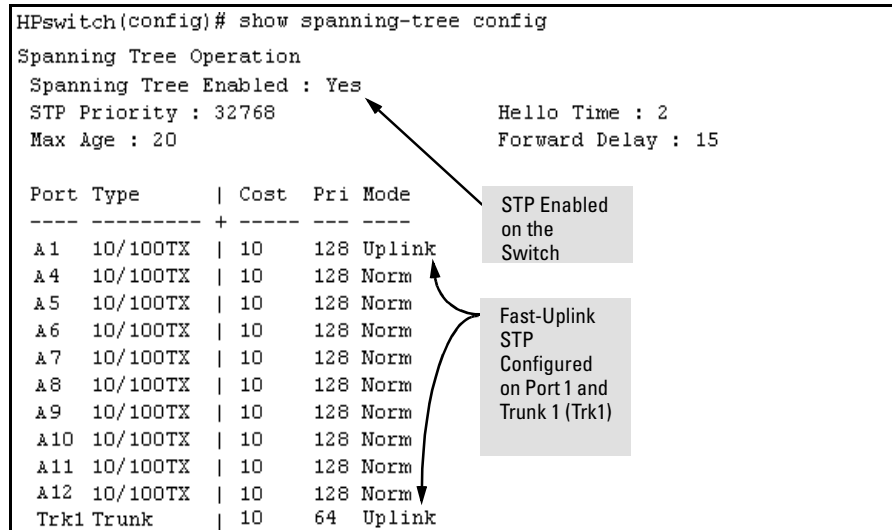

**Figure 13-22. Example of a Configuration Supporting the STP Topology Shown in Figure 13-20**

**Using the CLI To Configure Fast-Uplink STP.** This example uses the CLI to configure the switch for the fast-uplink operation shown in figures 13-20, 13-21, and 13-22. (The example assumes that ports A2 and A3 are already configured as members of the port trunk—Trk1, and all other STP parameters are left in their default state.)

Note that the default STP Protocol Version is RSTP (Rapid STP, or 802.1w). Thus, if the switch is set to the STP default, you must change it to the STP (802.1d) Protocol Version before you can configure Fast-Uplink. For example:

```
HPswitch(config)# show spanning-tree
Status and Counters - Spanning Tree Information
Protocol Version : RSTP
STP Enabled : No
Port Type      Cost      Priority State | Designated Bridge
-----+-----+-----+-----+-----+
HPswitch(config)# spanning-tree protocol-version stp
STP version was changed. To activate the change you must
save the configuration to flash and reboot the device.
HPswitch(config)# write mem
HPswitch(config)# boot
Device will be rebooted, do you want to continue [y/n]? y
Boot from primary flash
```

Lists STP configuration.  
Shows the default STP protocol

1. Changes the Spanning-Tree protocol to STP (required for Fast-Uplink).
2. Saves the change to the startup-configuration
3. Reboots the switch. (Required for this configuration change.)

Figure 13-23. Example of Changing the STP Configuration from the Default RSTP (802.1w) to STP (802.1d)

**Syntax:** spanning-tree e <port/trunk-list> mode uplink Enables STP on the switch and configures fast-uplink STP on the designated interfaces (port or trunk).

For example:

```
HPswitch(config)# spanning-tree e A1, trk1 mode uplink
```

## Operating Notes

**Effect of Reboots on Fast-Uplink STP Operation.** When configured, fast-uplink STP operates on the designated ports in a running switch. However, if the switch experiences a reboot, the fast-uplink ports (Mode = **Uplink**) use the longer forwarding delay used by ports on standard 802.1D STP (non fast-uplink). This prevents temporary loops that could otherwise result while the switch is determining the STP status for all ports. That is, on ports configured for fast-uplink STP, the first STP state transition after a reboot takes the same amount of time as for redundant ports that are not configured for fast-uplink STP.

**Using Fast Uplink with Port Trunks.** To use a port trunk for fast-uplink STP, configure it in the same way that you would an individual port for the same purpose. A port trunk configured for fast uplink operates in the same way as an individual, non-trunked port operates; that is, as a logical port.

---

**Note**

When you add a port to a trunk, the port takes on the STP mode configured for the trunk, regardless of which STP mode was configured on the port before it was added to the trunk. Thus, all ports belonging to a trunk configured with **Uplink** in the STP **Mode** field will operate in the fast-uplink mode. (If you remove a port from a trunk, the port reverts to the STP Mode setting it had before you added the port to the trunk.)

To use fast uplink over a trunk, you must:

1. Create the trunk.
2. Configure the trunk for fast uplink in the same way that you would configure an individual port for fast uplink.

When you first create a port trunk, its STP Mode setting will be **Norm**, regardless of whether one or more ports in the trunk are set to fast uplink (Mode = **Uplink**). You must still specifically configure the trunk Mode setting to **Uplink**. Similarly, if you eliminate a trunk, the Mode setting on the individual ports in the trunk will return to their previous settings.

**For Troubleshooting Information on Fast Uplink.** Refer to “Spanning-Tree Protocol (STP) and Fast-Uplink Problems” on page C-14 (in the “Troubleshooting” appendix).

---

## Web: Enabling or Disabling STP

In the web browser interface you can enable or disable STP on the switch. To configure other STP features, telnet to the switch console and use the CLI.

To enable or disable STP on the switch:

1. Click on the **Configuration** tab
2. Click on .
3. Enable or disable STP.
4. Click on  to implement the configuration change.

For web-based help on how to use the web browser interface screen, click on the  button provided on the web browser screen.

**802.1w Rapid Spanning Tree Protocol (RSTP) and 802.1d Spanning Tree Protocol (STP)**  
Web: Enabling or Disabling STP

# HP Procurve Stack Management

---

## Contents

<b>Overview</b> .....	14-2
<b>Operation</b> .....	14-3
Which Devices Support Stacking? .....	14-4
Components of HP Procurve Stack Management .....	14-5
General Stacking Operation .....	14-5
Operating Rules for Stacking .....	14-6
<b>Configuring Stack Management</b> .....	14-9
Overview of Configuring and Bringing Up a Stack .....	14-9
General Steps for Creating a Stack .....	14-11
Using the Menu Interface To View Stack Status and Configure Stacking .....	14-13
Using the Commander To Manage The Stack .....	14-17
Monitoring Stack Status .....	14-25
Using the CLI To View Stack Status and Configure Stacking .....	14-29
Using the CLI To View Stack Status .....	14-31
Using the CLI To Configure a Commander Switch .....	14-33
Adding to a Stack or Moving Switches Between Stacks .....	14-35
Using the CLI To Remove a Member from a Stack .....	14-40
Using the CLI To Access Member Switches for Configuration Changes and Traffic Monitoring .....	14-42
SNMP Community Operation in a Stack .....	14-43
Using the CLI To Disable or Re-Enable Stacking .....	14-44
Transmission Interval .....	14-44
Stacking Operation with Multiple VLANs Configured .....	14-44
Web: Viewing and Configuring Stacking .....	14-45
Status Messages .....	14-46

## Overview

This chapter describes how to use your network to stack switches without the need for any specialized cabling—page 14-3.

For general information on how to use the switch's built-in interfaces, see:

- Chapter 2, “Using the Menu Interface”
- Chapter 3, “Using the Command Line Interface (CLI)”
- Chapter 4, “Using the HP Web Browser Interface
- Chapter 5, “Switch Memory and Configuration”



# Operation

## Stacking Features

Feature	Default	Menu	CLI	Web
<b>view stack status</b>				
view status of a single switch	n/a	page 14-26 thru page 14-28	page 14-31	page 14-45
view candidate status	n/a		page 14-31	
view status of commander and its stack	n/a		page 14-32	
view status of all stacking-enabled switches in the ip subnet	n/a		page 14-32	
<b>configure stacking</b>				
enable/disable candidate Auto-Join	enabled/Yes	page 14-15	page 14-37	
“push” a candidate into a stack	n/a	page 14-15	page 14-37	
configure a switch to be a commander	n/a	page 14-13	page 14-33	
“push” a member into another stack	n/a	page 14-24	page 14-39	
remove a member from a stack	n/a	page 14-21	page 14-40 or page 14-41	
“pull” a candidate into a stack	n/a	page 14-17	page 14-36	
“pull” a member from another stack	n/a	page 14-19	page 14-38	
convert a commander or member to a member of another stack	n/a	page 14-24	page 14-39	
access member switches for configuration and traffic monitoring	n/a	page 14-23	page 14-42	
disable stacking	enabled	page 14-15	page 14-44	
transmission interval	60 seconds	page 14-13	page 14-44	

HP Procurve Stack Management (termed *stacking*) enables you to use a single IP address and standard network cabling to manage a group of up to 16 total switches in the same IP subnet (broadcast domain). Using stacking, you can:

- Reduce the number of IP addresses needed in your network.

- Simplify management of small workgroups or wiring closets while scaling your network to handle increased bandwidth demand.
- Eliminate any specialized cables for stacking connectivity and remove the distance barriers that typically limit your topology options when using other stacking technologies.
- Add switches to your network without having to first perform IP addressing tasks.

## Which Devices Support Stacking?

As of June, 2002, the following HP devices support stacking:

- 
- |                             |                             |
|-----------------------------|-----------------------------|
| ■ HP Procurve Switch 4104GL | ■ HP Procurve Switch 4000M* |
| ■ HP Procurve Switch 4108GL | ■ HP Procurve Switch 2424M* |
| ■ HP Procurve Switch 2512   | ■ HP Procurve Switch 2400M* |
| ■ HP Procurve Switch 2524   | ■ HP Procurve Switch 1600M* |
| ■ HP Procurve Switch 8000M* |                             |
- 

\*Requires software release C.08.03 or later, which is included with the 8000M, 4000M, 2424M, and 1600M models as of July, 2000. Release C.08.03 or a later version is also available on the HP Procurve website at [www.hp.com/go/procurve](http://www.hp.com/go/procurve). (Click on **software**.)

---

## Components of HP Procurve Stack Management

**Table 14-1. Stacking Definitions**

Stack	Consists of a Commander switch and any Member switches belonging to that Commander's stack.
Commander	A switch that has been manually configured as the controlling device for a stack. When this occurs, the switch's stacking configuration appears as <b>Commander</b> .
Candidate	A switch that is ready to join (become a Member of) a stack through either automatic or manual methods. A switch configured as a Candidate is not in a stack.
Member	A switch that has joined a stack and is accessible from the stack Commander.

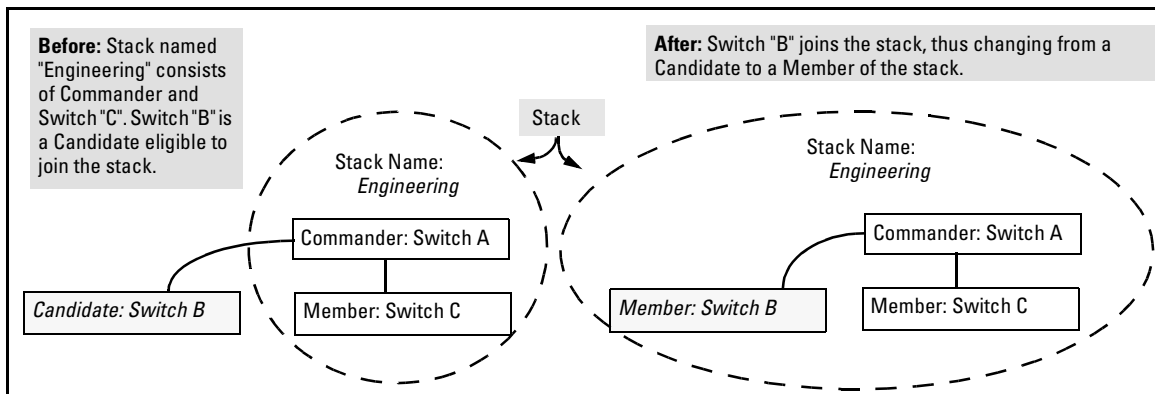

**Figure 14-1. Illustration of a Switch Moving from Candidate to Member**

## General Stacking Operation

After you configure one switch to operate as the Commander of a stack, additional switches can join the stack by either automatic or manual methods. After a switch becomes a Member, you can work through the Commander switch to further configure the Member switch as necessary for all of the additional software features available in the switch.

The Commander switch serves as the in-band entry point for access to the Member switches. For example, the Commander's IP address becomes the path to all stack Members and the Commander's Manager password controls access to all stack Members.

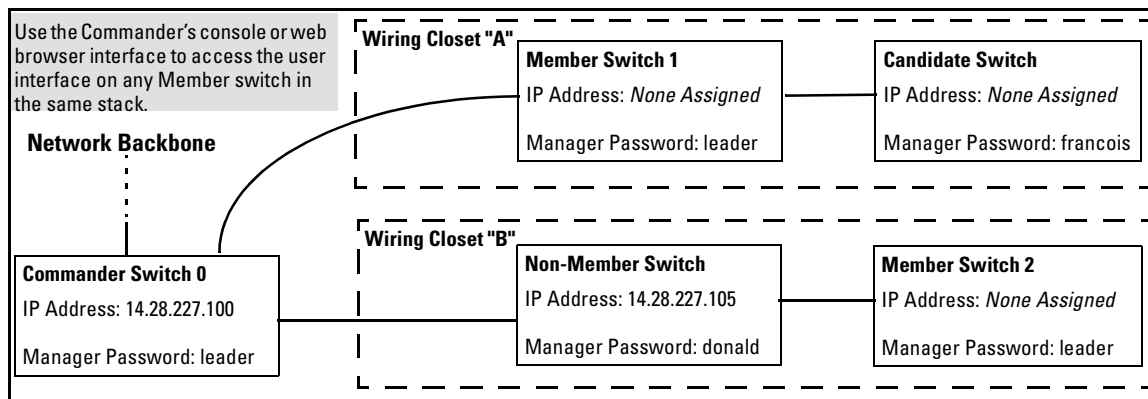

Figure 14-2. Example of Stacking with One Commander Controlling Access to Wiring Closet Switches

**Interface Options.** You can configure stacking through the switch's menu interface, CLI, or the web browser interface. For information on how to use the web browser interface to configure stacking, see the online Help for the web browser interface.

**Web Browser Interface Window for Commander Switches.** The web browser interface window for a Commander switch differs in appearance from the same window for non-commander switches. See figure 1-3 on page 1-5.

## Operating Rules for Stacking

### General Rules

- Stacking is an optional feature (enabled in the default configuration) and can easily be disabled. Stacking has no effect on the normal operation of the switch in your network.
- A stack requires one Commander switch. (Only one Commander allowed per stack.)
- All switches in a particular stack must be in the same IP subnet (broadcast domain). A stack cannot cross a router.
- A stack accepts up to 16 switches (numbered 0-15), including the Commander (always numbered 0).
- There is no limit on the number of stacks in the same IP subnet (broadcast domain), however a switch can belong to only one stack.

- If multiple VLANs are configured, stacking uses only the primary VLAN on any switch. In the factory-default configuration, the DEFAULT\_VLAN is the primary VLAN. (See “Stacking Operation with Multiple VLANs Configured” on page 14-44 and “The Primary VLAN” on page 11-6.)
- Stacking allows intermediate devices that do not support stacking. This enables you to include switches that are distant from the Commander.

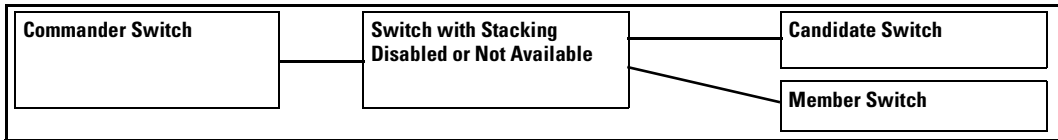

**Figure 14-3. Example of a Non-Stacking Device Used in a Stacking Environment**

## Specific Rules

**Table 14-2. Specific Rules for Commander, Candidate, and Member Switches**

	<b>IP Addressing and Stack Name</b>	<b>Number Allowed Per Stack</b>	<b>Passwords</b>	<b>SNMP Communities</b>
Commander	<b>IP Addr:</b> Requires an assigned IP address and mask for access via the network. <b>Stack Name:</b> Required	Only one Commander switch is allowed per stack.	The Commander's Manager and Operator passwords are assigned to any switch becoming a Member of the stack.  If you change the Commander's passwords, the Commander propagates the new passwords to all stack Members.	Standard SNMP community operation. The Commander also operates as an SNMP proxy to Members for all SNMP communities configured in the Commander.
Candidate	<b>IP Addr:</b> Optional. Configuring an IP address allows access via Telnet or web browser interface while the switch is not a stack member. In the factory default configuration the switch automatically acquires an IP address if your network includes DHCP service. <b>Stack Name:</b> N/A	n/a	Passwords optional. If the Candidate becomes a stack Member, it assumes the Commander's Manager and Operator passwords.  If a candidate has a password, it cannot be automatically added to a stack. In this case, if you want the Candidate in a stack, you must manually add it to the stack.	Uses standard SNMP community operation if the Candidate has its own IP addressing.
Member	<b>IP Addr:</b> Optional. Configuring an IP address allows access via Telnet or web browser interface without going through the Commander switch. This is useful, for example, if the stack Commander fails and you need to convert a Member switch to operate as a replacement Commander. <b>Stack Name:</b> N/A	Up to 15 Members per stack.	When the switch joins the stack, it automatically assumes the Commander's Manager and Operator passwords and discards any passwords it may have had while a Candidate.  <b>Note:</b> If a Member leaves a stack for any reason, it retains the passwords assigned to the stack Commander at the time of departure from the stack.	Belongs to the same SNMP communities as the Commander (which serves as an SNMP proxy to the Member for communities to which the Commander belongs). To join other communities that <i>exclude</i> the Commander, the Member must have its own IP address. Loss of stack membership means loss of membership in any community that is configured only in the Commander. See "SNMP Community Operation in a Stack" on page 14-43.

---

**Note**

In the default stack configuration, the Candidate **Auto Join** parameter is enabled, but the Commander **Auto Grab** parameter is disabled. This prevents Candidates from automatically joining a stack prematurely or joining the wrong stack (if more than one stack Commander is configured in a subnet or broadcast domain). If you plan to install more than one stack in a subnet, HP recommends that you leave **Auto Grab** disabled on all Commander switches and manually add Members to their stacks. Similarly, if you plan to install a stack in a subnet (broadcast domain) where stacking-capable switches are not intended for stack membership, you should set the **Stack State** parameter (in the Stack Configuration screen) to **Disabled** on those particular switches.

---

---

## Configuring Stack Management

### Overview of Configuring and Bringing Up a Stack

This process assumes that:

- All switches you want to include in a stack are connected to the same subnet (broadcast domain).
- If VLANs are enabled on the switches you want to include in the stack, then the ports linking the stacked switches must be on the primary VLAN in each switch (which, in the default configuration, is the default VLAN). If the primary VLAN is tagged, then each switch in the stack must use the same VLAN ID (VID) for the primary VLAN. (See “The Primary VLAN” on page 11-6, and “Stacking Operation with Multiple VLANs Configured” on page 14-44.)
- If you are including an HP Procurve Switch 8000M, 4000M, 2424M, 2400M, or 1600M in a stack, you must first update all such devices to software version C.08.03 or later. (You can get a copy of the software from HP’s Procurve website and/or copy it from one switch to another. For downloading instructions, see appendix A, “File Transfers”, in the *Management and Configuration Guide* you received with these switch models.)

**Options for Configuring a Commander and Candidates.** Depending on how Commander and Candidate switches are configured, Candidates can join a stack either automatically or by a Commander manually adding (“pulling”) them into the stack. In the default configuration, a Candidate joins only when *manually* pulled by a Commander. You can reconfigure a Commander to *automatically* pull in Candidates that are in the default stacking configuration. You can also reconfigure a Candidate switch to either “push” itself into a particular Commander’s stack, convert the Candidate to a Commander (for a stack that does not already have a Commander), or to operate as a standalone switch without stacking. The following table shows your control options for adding Members to a stack.

**Table 14-3. Stacking Configuration Guide**

Join Method <sup>1</sup>	Commander (IP Addressing Required)	Candidate (IP Addressing Optional)	
	Auto Grab	Auto Join	Passwords
Automatically add Candidate to Stack (Causes the first 15 eligible, discovered switches in the subnet to automatically join a stack.)	<b>Yes</b>	<b>Yes (default)</b>	No (default)*
Manually add Candidate to Stack (Prevent automatic joining of switches you don’t want in the stack)	<b>No (default)</b>	<b>Yes (default)</b>	Optional*
	<b>Yes</b>	<b>No</b>	Optional*
	<b>Yes</b>	<b>Yes (default) or No</b>	Configured
Prevent a switch from being a Candidate	N/A	<b>Disabled</b>	Optional

\*The Commander’s Manager and Operator passwords propagate to the candidate when it joins the stack.

The easiest way to *automatically* create a stack is to:

1. Configure a switch as a Commander.
2. Configure IP addressing and a stack name on the Commander.
3. Set the Commander’s **Auto Grab** parameter to **Yes**.
4. Connect Candidate switches (in their factory default configuration) to the network.

This approach automatically creates a stack of up to 16 switches (including the Commander). However this replaces manual control with an automatic process that may bring switches into the stack that you did not intend to include. With the Commander’s **Auto Grab** parameter set to **Yes**, *any switch* conforming to all four of the following factors automatically becomes a stack Member:



- Default stacking configuration (**Stack State** set to **Candidate**, and **Auto Join** set to **Yes**)
- Same subnet (broadcast domain) and default VLAN as the Commander (If VLANs are used in the stack environment, see "Stacking Operation with a Tagged VLAN" on page 14-44.)
- No Manager password
- 14 or fewer stack members at the moment

### General Steps for Creating a Stack

This section describes the general stack creation process. For the detailed configuration processes, see pages 14-13 through 14-36 for the menu interface and pages 14-29 through 14-41 for the CLI.

1. Determine the naming conventions for the stack. You will need a stack name. Also, to help distinguish one switch from another in the stack, you can configure a unique system name for each switch. Otherwise, the system name for a switch appearing in the Stacking Status screen appears as the stack name plus an automatically assigned switch number. For example:

```

Pacific Ocean
-----
CONSOLE - MANAGER MODE -----
Stacking - Stacking Status (All)

Stack Name      MAC Address      System Name      Status
-----
Big Waters      (0060b0-880a80  Pacific Ocean )  Commander Up
                (0060b0-df1a00  Coral Sea   )  Member Up
Online          (0060b0-df7680  online-0   )  Commander Up
                (001083-3c7480  online-1   )  Member Up
                (0060b0-312f00  online-2   )  Member Up
                (001083-3c09c0  online-3   )  Member Up

Actions->  Back  Next page  Prev page  Help
Return to previous screen.
Use up/down arrow keys to scroll to other entries, left/right arrow keys to
change action selection, and <Enter> to execute action.
  
```

For status descriptions, see the table on page 14-46.

Stack with unique system name for each switch.

Stack named "Online" with no previously configured system names assigned to individual switches.

Figure 14-4. Using the System Name to Help Identify Individual Switches

2. Configure the Commander switch. Doing this first helps to establish consistency in your stack configuration, which can help prevent startup problems.
  - A stack requires one Commander switch. If you plan to implement more than one stack in a subnet (broadcast domain), the easiest way to avoid unintentionally adding a Candidate to the wrong stack is to manually control the joining process by leaving the Commander's **Auto Grab** parameter set to **No** (the default).
  - The Commander assigns its Manager and Operator passwords to any Candidate switch that joins the stack.
  - The Commander's SNMP community names apply to members.
3. For automatically or manually pulling Candidate switches into a stack, you can leave such switches in their default stacking configuration. If you need to access Candidate switches through your network before they join the stack, assign IP addresses to these devices. Otherwise, IP addressing is optional for Candidates and Members. (Note that once a Candidate becomes a member, you can access it through the Commander to assign IP addressing or make other configuration changes.)
4. Make a record of any Manager passwords assigned to the switches (intended for your stack) that are not currently members. (You will use these passwords to enable the protected switches to join the stack.)
5. If you are using VLANs in the stacking environment, you must use the default VLAN for stacking links. For more information, see "Stacking Operation with a Tagged VLAN" on page 14-44.
6. Ensure that all switches intended for the stack are connected to the same subnet (broadcast domain). As soon as you connect the Commander, it will begin discovering the available Candidates in the subnet.
  - If you configured the Commander to automatically add Members (**Auto Grab = Yes**), the first 15 discovered Candidates meeting both of the following criteria will automatically join the stack:
    - **Auto Join** parameter set to **Yes** (the default)
    - Manager password not configured
  - If you configured the Commander to manually add Members (**Auto Grab** set to **No**—the default), you can begin the process of selecting and adding the desired Candidates.
7. Ensure that all switches intended for the stack have joined.
8. If you need to do specific configuration or monitoring tasks on a Member, use the console interface on the Commander to access the Member.

## Using the Menu Interface To View Stack Status and Configure Stacking

### Using the Menu Interface To View and Configure a Commander Switch

1. Configure an IP address and subnet mask on the Commander switch. (See Chapter 7, “Configuring IP Addressing”.)
2. Display the Stacking Menu by selecting **Stacking** in the Main Menu.

```
DEFAULT_CONFIG
----- CONSOLE - MANAGER MODE -----
                Stacking Menu

1. Stacking Status (This Switch)
2. Stacking Status (All)
3. Stack Configuration
0. Return to Main Menu...

Shows the status of Stack.
To select menu item, press item number, or highlight item and press <Enter>.
```

Figure 14-5. The Default Stacking Menu

3. Display the Stack Configuration menu by pressing **3** to select **Stack Configuration**.

```
DEFAULT_CONFIG
----- CONSOLE - MANAGER MODE -----
                Stacking - Stack Configuration

Stack State : Candidate
Auto Join [Yes] : Yes
Transmission Interval [60] : 60

Actions->  Cancel  Edit  Save  Help

Cancel changes and return to previous screen.
Use arrow keys to change action selection and <Enter> to execute action.
```

Figure 14-6. The Default Stack Configuration Screen

4. Move the cursor to the Stack State field by pressing **[E]** (for **E**dit). Then use the Space bar to select the **Commander** option.
5. Press the downarrow key to display the Commander configuration fields in the Stack Configuration screen.

```
DEFAULT_CONFIG
-----
          CONSOLE - MANAGER MODE -----
          Stacking - Stack Configuration

Stack State : Commander
Stack Name : ██████████
Auto Grab [No] : No
Transmission Interval [60] : 60

Actions->  Cancel      Edit      Save      Help
██████████
Use arrow keys to change field selection, <Space> to toggle field choices,
and <Enter> to go to Actions.
```

**Figure 14-7. The Default Commander Configuration in the Stack Configuration Screen**

6. Enter a unique stack name (up to 15 characters; no spaces) and press the downarrow key.
7. Ensure that the Commander has the desired **Auto Grab** setting, then press the downarrow key:
  - **No** (the default) prevents automatic joining of Candidates that have their **Auto Join** set to **Yes**.
  - **Yes** enables the Commander to automatically take a Candidate into the stack as a Member if the Candidate has **Auto Join** set to **Yes** (the default Candidate setting) and does not have a previously configured password.
8. Accept or change the transmission interval (default: 60 seconds), then press **[Enter]** to return the cursor to the **Actions** line.
9. Press **[S]** (for **S**ave) to save your configuration changes and return to the Stacking menu.

Your Commander switch should now be ready to automatically or manually acquire Member switches from the list of discovered Candidates, depending on your configuration choices.

## Using the Menu To Manage a Candidate Switch

Using the menu interface, you can perform these actions on a Candidate switch:

- Add (“push”) the Candidate into an existing stack
- Modify the Candidate’s stacking configuration (**Auto Join** and **Transmission Interval**)
- Convert the Candidate to a Commander
- Disable stacking on the Candidate so that it operates as a standalone switch

In its default stacking configuration, a Candidate switch can either automatically join a stack or be manually added (“pulled”) into a stack by a Commander, depending on the Commander’s **Auto Grab** setting. The following table lists the Candidate’s configuration options:

**Table 14-4. Candidate Configuration Options in the Menu Interface**

Parameter	Default Setting	Other Settings
<b>Stack State</b>	Candidate	Commander, Member, or Disabled
<b>Auto Join</b>	Yes	No
<b>Transmission Interval</b>	60 Seconds	Range: 1 to 300 seconds

**Using the Menu To “Push” a Switch Into a Stack, Modify the Switch’s Configuration, or Disable Stacking on the Switch.** Use Telnet or the web browser interface to access the Candidate if it has an IP address. Otherwise, use a direct connection from a terminal device to the switch’s console port. (For information on how to use the web browser interface, see the online Help provided for the browser.)

1. Display the Stacking Menu by selecting **Stacking** in the console Main Menu.
2. Display the Stack Configuration menu by pressing [3] to select **Stack Configuration**.

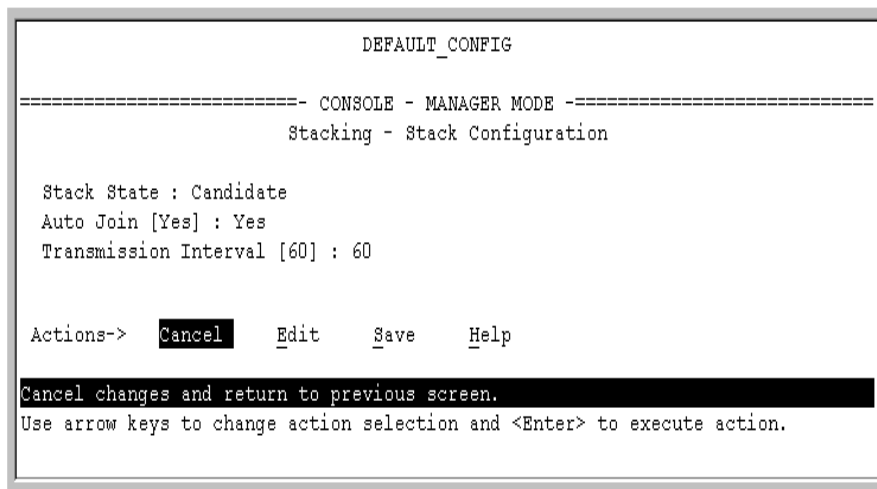

**Figure 14-8. The Default Stack Configuration Screen**

3. Move the cursor to the Stack State field by pressing **[E]** (for **E**dit).
4. Do one of the following:
  - To disable stacking on the Candidate, use the Space bar to select the **Disabled** option, then go to step 5.  
**Note:** Using the menu interface to disable stacking on a Candidate removes the Candidate from all stacking menus.
  - To insert the Candidate into a specific Commander's stack:
    - i. Use the space bar to select Member.
    - ii. Press **[Tab]** once to display the **Commander MAC Address** parameter, then enter the MAC address of the desired Commander.
  - To change **Auto Join** or **Transmission Interval**, use **[Tab]** to select the desired parameter, and:
    - To change **Auto Join**, use the Space bar.
    - To change **Transmission Interval**, type in the new value in the range of 1 to 300 seconds.  
**Note:** All switches in the stack must be set to the same transmission interval to help ensure proper stacking operation. HP recommends that you leave this parameter set to the default 60 seconds.

Then go to step 5.

5. press **[Enter]** to return the cursor to the **Actions** line.

6. Press **S** (for **Save**) to save your configuration changes and return to the Stacking menu.

## Using the Commander To Manage The Stack

The Commander normally operates as your stack manager and point of entry into other switches in the stack. This typically includes:

- Adding new stack members
- Moving members between stacks
- Removing members from a stack
- Accessing stack members for individual configuration changes and traffic monitoring

The Commander also imposes its passwords on all stack members and provides SNMP community membership to the stack. (See “SNMP Community Operation in a Stack” on page 14-43.)

**Using the Commander’s Menu To Manually Add a Candidate to a Stack.** In the default configuration, you must manually add stack Members from the Candidate pool. Reasons for a switch remaining a Candidate instead of becoming a Member include any of the following:

- **Auto Grab** in the Commander is set to **No** (the default).
- **Auto Join** in the Candidate is set to **No**.  
**Note:** When a switch leaves a stack and returns to Candidate status, its **Auto Join** parameter resets to **No** so that it will not immediately rejoin a stack from which it has just departed.
- A Manager password is set in the Candidate.
- The stack is full.

Unless the stack is already full, you can use the Stack Management screen to manually convert a Candidate to a Member. If the Candidate has a Manager password, you will need to use it to make the Candidate a Member of the stack.

1. To add a Member, start at the Main Menu and select:

**9. Stacking...**

**4. Stack Management**

You will then see the Stack Management screen:

For status descriptions, see the table on page 14-46.

```

Pacific Ocean
-----
CONSOLE - MANAGER MODE -----
Stacking - Stack Management

SN      MAC Address      System Name      Device Type      Status
-----
1      0060b0-df1a00    Coral Sea        HP 8000M        Member Up
2      080009-8c5080    North Atlantic   HP 8000M        Member Up

Actions->  Back      Add      Edit      Delete      Help

Return to previous screen.
Use up/down arrow keys to change record selection, left/right arrow keys to
change action selection, and <Enter> to execute action.

```

**Figure 14-9. Example of the Stack Management Screen**

2. Press **[A]** (for **Add**) to add a Candidate. You will then see this screen listing the available Candidates:

```

Pacific Ocean
-----
CONSOLE - MANAGER MODE -----
Stacking - Stack Management

Switch Number : 3
MAC Address :
Candidate Password :

Candidate MAC      System Name      Device Type
-----
0060b0-e94300    DEFAULT_CONFIG   HP 8000M
080009-918f80    DEFAULT_CONFIG   HP 4000M

Actions->  Cancel      Edit      Save      Help

Use arrow keys to change field selection, <Space> to toggle field choices,
and <Enter> to go to Actions.

```

**Figure 14-10. Example of Candidate List in Stack Management Screen**

3. Either accept the displayed switch number or enter another available number. (The range is 0 - 15, with 0 reserved for the Commander.)
4. Use the downarrow key to move the cursor to the MAC Address field, then type the MAC address of the desired Candidate from the Candidate list in the lower part of the screen.
5. Do one of the following:



- If the desired Candidate has a Manager password, press the downarrow key to move the cursor to the Candidate Password field, then type the password.
  - If the desired Candidate does not have a password, go to step 6.
6. Press **[Enter]** to return to the Actions line, then press **[S]** (for **Save**) to complete the Add process for the selected Candidate. You will then see a screen similar to the one in figure 14-11, below, with the newly added Member listed.

**Note:** If the message **Unable to add stack member: Invalid Password** appears in the console menu's Help line, then you either omitted the Candidate's Manager password or incorrectly entered the Manager password.

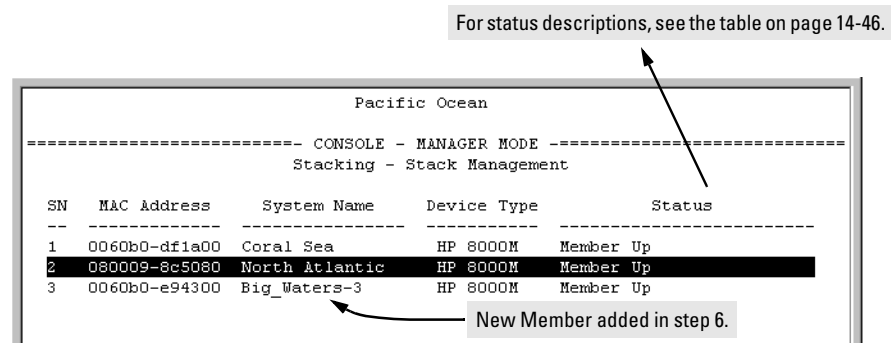

**Figure 14-11. Example of Stack Management Screen After New Member Added**

**Using the Commander's Menu To Move a Member From One Stack to Another.** Where two or more stacks exist in the same subnet (broadcast domain), you can easily move a Member of one stack to another stack if the destination stack is not full. (If you are using VLANs in your stack environment, see "Stacking Operation with a Tagged VLAN" on page 14-44.) This procedure is nearly identical to manually adding a Candidate to a stack (page 14-17). (If the stack from which you want to move the Member has a Manager password, you will need to know the password to make the move.)

1. To move a Member from one stack to another, go to the Main Menu of the Commander in the destination stack and display the Stacking Menu by selecting
 

**9. Stacking...**
2. To learn or verify the MAC address of the Member you want to move, display a listing of all Commanders, Members, and Candidates in the subnet by selecting:

## 2. Stacking Status (All)

You will then see the Stacking Status (All) screen:

For status descriptions, see the table on page 14-46.

Stack Name	MAC Address	System Name	Status
Big Waters	0060b0-880a80	Pacific Ocean	Commander Up
	0060b0-df1a00	Coral Sea	Member Up
Newstack	080009-8c5080	North Atlantic	Member Up
	001083-c3fc00	Newstack-0	Commander Up
	080009-918f80	Newstack-1	Member Up
	0060b0-df2a00	Newstack-2	Member Up
Others:	001083-3c09c0	DEFAULT_CONFIG	Candidate
	0060b0-e94300	DEFAULT_CONFIG	Candidate
	080009-918f80	DEFAULT_CONFIG	Candidate

Actions-> **Back** Next page Prev page Help

Return to previous screen.  
Use up/down arrow keys to scroll to other entries, left/right arrow keys to change action selection, and <Enter> to execute action.

**Figure 14-12. Example of How the Stacking Status (All) Screen Helps You Find Member MAC Addresses**

3. In the Stacking Status (All) screen, find the Member switch that you want to move and note its MAC address, then press **[B]** (for **Back**) to return to the Stacking Menu.

4. Display the Commander's Stack Management screen by selecting

### 4. Stack Management

(For an example of this screen, see figure 14-9 on page 14-18.)

5. Press **[A]** (for **Add**) to add the Member. You will then see a screen listing any available candidates. (See figure 14-10 on page 14-18.) Note that you will not see the switch you want to add because it is a Member of another stack and not a Candidate.)

6. Either accept the displayed switch number or enter another available number. (The range is 0 - 15, with 0 reserved for the Commander.)

7. Use the downarrow key to move the cursor to the MAC Address field, then type the MAC address of the desired Member you want to move from another stack.

8. Do one of the following:
  - If the stack containing the Member you are moving has a Manager password, press the downarrow key to select the Candidate Password field, then type the password.
  - If the stack containing the Member you want to move does not have a password, go to step 9.
9. Press **[Enter]** to return to the Actions line, then press **[S]** (for **Save**) to complete the Add process for the selected Member. You will then see a screen similar to the one in figure 14-9 on page 14-18, with the newly added Member listed.

---

**Note:**

If the message **Unable to add stack member: Invalid Password** appears in the console menu's Help line, then you either omitted the Manager password for the stack containing the Member or incorrectly entered the Manager password.

You can “push” a Member from one stack to another by going to the Member's interface and entering the MAC address of the destination stack Commander in the Member's **Commander MAC Address** field. Using this method moves the Member to another stack without a need for knowing the Manager password in that stack, but also blocks access to the Member from the original Commander.

---

**Using the Commander's Menu To Remove a Stack Member.** These rules affect removals from a stack:

- When a Candidate becomes a Member, its **Auto Join** parameter is automatically set to **No**. This prevents the switch from automatically rejoining a stack as soon as you remove it from the stack.
- When you use the Commander to remove a switch from a stack, the switch rejoins the Candidate pool for your IP subnet (broadcast domain), with **Auto Join** set to **No**.
- When you remove a Member from a stack, it frees the previously assigned switch number (**SN**), which then becomes available for assignment to another switch that you may subsequently add to the stack. The default switch number used for an add is the lowest unassigned number in the Member range (1 - 15; 0 is reserved for the Commander).

To remove a Member from a stack, use the Stack Management screen.

1. From the Main Menu, select:

**9. Stacking...**

**4. Stack Management**

You will then see the Stack Management screen:

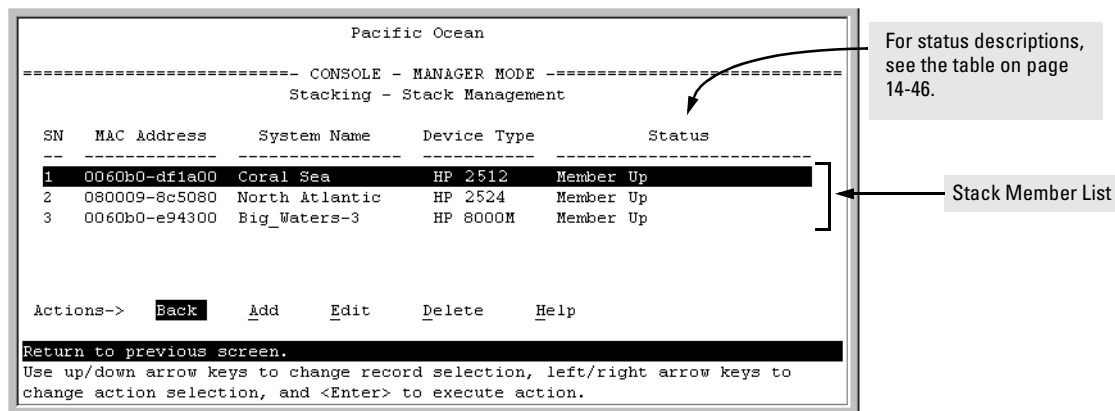

**Figure 14-13. Example of Stack Management Screen with Stack Members Listed**

2. Use the downarrow key to select the Member you want to remove from the stack.

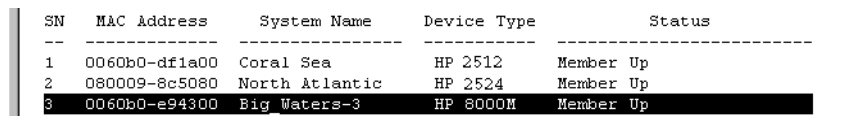

**Figure 14-14. Example of Selecting a Member for Removal from the Stack**

3. Type **[D]** (for **Delete**) to remove the selected Member from the stack. You will then see the following prompt:

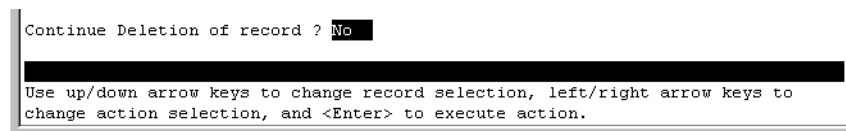

**Figure 14-15. The Prompt for Completing the Deletion of a Member from the Stack**

- To continue deleting the selected Member, press the Space bar once to select **Yes** for the prompt, then press **[Enter]** to complete the deletion. The Stack Management screen updates to show the new stack Member list.

## Using the Commander To Access Member Switches for Configuration Changes and Monitoring Traffic

After a Candidate becomes a stack Member, you can use that stack's Commander to access the Member's console interface for the same configuration and monitoring that you would do through a Telnet or direct-connect access.

- From the Main Menu, select:

### 9. Stacking...

#### 5. Stack Access

You will then see the Stack Access screen:

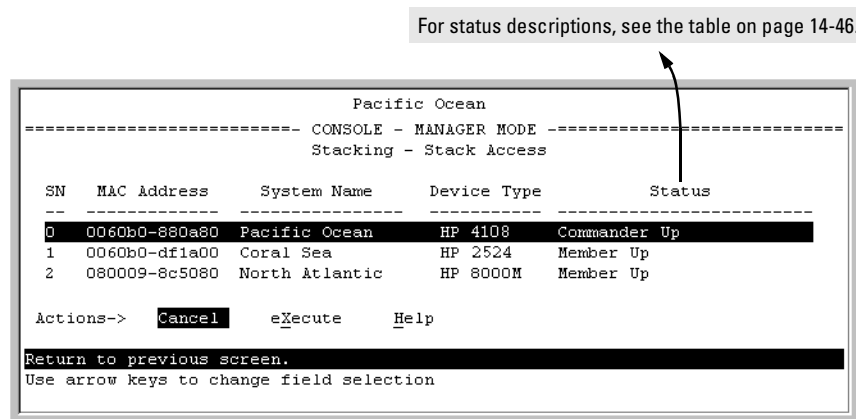

**Figure 14-16. Example of the Stack Access Screen**

Use the downarrow key to select the stack Member you want to access, then press **[X]** (for **eXecute**) to display the console interface for the selected Member. For example, if you selected switch number 1 (system name: **Coral Sea**) in figure 14-16 and then pressed **[X]**, you would see the Main Menu for the switch named Coral Sea.

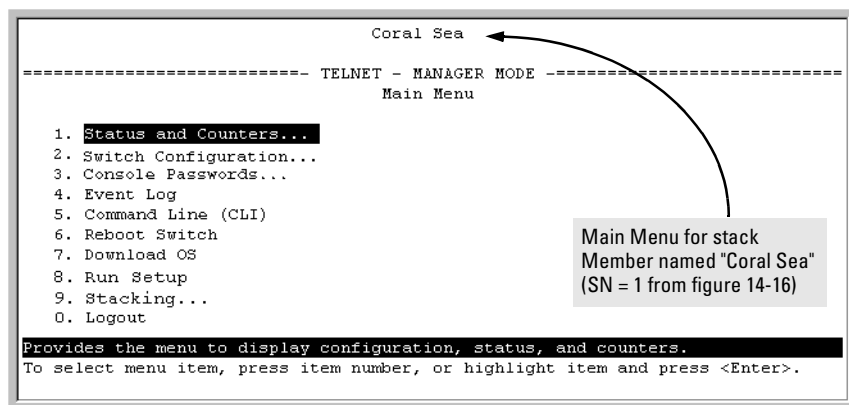

**Figure 14-17. The eXecute Command Displays the Console Main Menu for the Selected Stack Member**

2. You can now make configuration changes and/or view status data for the selected Member in the same way that you would if you were directly connected or telnetted into the switch.
3. When you are finished accessing the selected Member, do the following to return to the Commander's Stack Access screen:
  - a. Return to the Member's Main Menu.
  - b. Press **[0]** (for Logout), then **[Y]** (for Yes).
  - c. Press **[Return]**.

You should now see the Commander's Stack Access screen. (For an example, see figure 14-16 on page 14-23.)

## Converting a Commander or Member to a Member of Another Stack

When moving a commander, the following procedure returns the stack members to Candidate status (with Auto-Join set to "No") and converts the stack Commander to a Member of another stack. When moving a member, the procedure simply pulls a Member out of one stack and pushes it into another.

1. From the Main Menu of the switch you want to move, select
  - 9. Stacking**
2. To determine the MAC address of the destination Commander, select
  - 2. Stacking Status (All)**

3. Press **[B]** (for **Back**) to return to the Stacking Menu.
4. To display Stack Configuration menu for the switch you are moving, select

### 3. Stack Configuration

5. Press **[E]** (for **Edit**) to select the Stack State parameter.
6. Use the Space bar to select **Member**, then press **[↓]** to move to the **Commander MAC Address** field.
7. Enter the MAC address of the destination Commander and press **[Enter]**.
8. Press **[S]** (for **Save**).

## Monitoring Stack Status

Using the stacking options in the menu interface for any switch in a stack, you can view stacking data for that switch or for all stacks in the subnet (broadcast domain). (If you are using VLANs in your stack environment, see "Stacking Operation with a Tagged VLAN" on page 14-44.) This can help you in such ways as determining the stacking configuration for individual switches, identifying stack Members and Candidates, and determining the status of individual switches in a stack. See table 14-14-5 on page 14-25.

**Table 14-5. Stack Status Environments**

Screen Name	Commander	Member	Candidate
Stack Status (This Switch)	<ul style="list-style-type: none"> <li>• Commander's stacking configuration</li> <li>• Data on stack Members:               <ul style="list-style-type: none"> <li>– Switch Number</li> <li>– MAC Address</li> <li>– System Name</li> <li>– Device Type</li> <li>– Status</li> </ul> </li> </ul>	<ul style="list-style-type: none"> <li>• Member's stacking configuration</li> <li>• Member Status</li> <li>• Data identifying Member's Commander:               <ul style="list-style-type: none"> <li>– Commander Status</li> <li>– Commander IP Address</li> <li>– Commander MAC Address</li> </ul> </li> </ul>	Candidate's stacking configuration
Stack Status (All)	Lists devices by stack name or Candidate status (if device is not a stack Member). Includes: <ul style="list-style-type: none"> <li>• Stack Name</li> <li>• MAC Address</li> <li>• System Name</li> <li>• Status</li> </ul>	Same as for Commander.	Same as for Commander.

**Using Any Stacked Switch To View the Status for All Switches with Stacking Enabled.** This procedure displays the general status of all switches in the IP subnet (broadcast domain) that have stacking enabled.

1. Go to the console Main Menu for any switch configured for stacking and select:

**9. Stacking ...**

**2. Stacking Status (All)**

You will then see a Stacking Status screen similar to the following:

For status descriptions, see the table on page 14-46.

```
Pacific Ocean
----- CONSOLE - MANAGER MODE -----
Stacking - Stacking Status (All)

Stack Name      MAC Address      System Name      Status
-----
Big Waters      0060b0-880a80   Pacific Ocean   Commander Up
                0060b0-df1a00   Coral Sea       Member Up
                080009-8c5080   North Atlantic  Member Up
Newstack        001083-c3fc00   Newstack-0      Commander Up
                080009-918f80   Newstack-1      Member Up
                0060b0-df2a00   Newstack-2      Member Up
Others:         001083-3c09c0   DEFAULT_CONFIG  Candidate
                0060b0-e94300   DEFAULT_CONFIG  Candidate
                080009-918f80   DEFAULT_CONFIG  Candidate

Actions->  Back  Next page  Prev page  Help
Return to previous screen.
Use up/down arrow keys to scroll to other entries, left/right arrow keys to
change action selection, and <Enter> to execute action.
```

**Figure 14-18. Example of Stacking Status for All Detected Switches Configured for Stacking**

**Viewing Commander Status.** This procedure displays the Commander and stack configuration, plus information identifying each stack member.

To display the status for a Commander, go to the console Main Menu for the switch and select:

**9. Stacking ...**

**1. Stacking Status (This Switch)**



You will then see the Commander's Stacking Status screen:

```

Pacific Ocean
-----
----- CONSOLE - MANAGER MODE -----
Stacking - Stacking Status (This Switch)

Stack State      : Commander
Transmission Interval : 60
Stack Name       : Big_Waters Number of members      : 2
Auto Grab       : No           Members unreachable   : 0

SN   MAC Address   System Name   Device Type   Status
-----
0   0060b0-880a80  Pacific Ocean HP 4108      Commander Up
1   0060b0-df1a00  Coral Sea    HP 2524      Member Up
2   080009-8c5080  North Atlantic HP 8000M     Member Up

Actions->  Back      Help

Return to previous screen.
Use arrow keys to change action selection and <Enter> to execute action.

```

**Figure 14-19. Example of the Commander's Stacking Status Screen**

**Viewing Member Status.** This procedure displays the Member's stacking information plus the Commander's status, IP address, and MAC address.

To display the status for a Member:

1. Go to the console Main Menu of the Commander switch and select
  - 9. Stacking ...**
  - 5. Stack Access**
2. Use the downarrow key to select the Member switch whose status you want to view, then press **[X]** (for **eXecute**). You will then see the Main Menu for the selected Member switch.
3. In the Member's Main Menu screen, select
  - 9. Stacking ...**
  - 1. Stacking Status (This Switch)**

You will then see the Member's Stacking Status screen:

```

Coral Sea
----- TELNET - MANAGER MODE -----
Stacking - Stacking Status (This Switch)

Stack State           : Member
Transmission Interval : 60
Switch Number        : 1
Stack Name            : Big_Waters
Member Status         : Joined Successfully
Commander Status      : Commander Up
Commander IP Address  : 13.28.227.102
Commander MAC Address : 0060b0-880a80

Actions->  Back  Help
Return to previous screen.
Use arrow keys to change action selection and <Enter> to execute action.

```

**Figure 14-20. Example of a Member’s Stacking Status Screen**

**Viewing Candidate Status.** This procedure displays the Candidate’s stacking configuration.

To display the status for a Candidate:

1. Use Telnet (if the Candidate has a valid IP address for your network) or a direct serial port connection to access the menu interface Main Menu for the Candidate switch and select

**9. Stacking ...**

**1. Stacking Status (This Switch)**

You will then see the Candidate’s Stacking Status screen:

```

Coral Sea
----- TELNET - MANAGER MODE -----
Stacking - Stacking Status (This Switch)

Stack State           : Candidate
Transmission Interval : 60
Auto Join             : No

Actions->  Back  Help
Return to previous screen.
Use arrow keys to change action selection and <Enter> to execute action.

```

**Figure 14-21. Example of a Candidate’s Stacking Screen**

## Using the CLI To View Stack Status and Configure Stacking

The CLI enables you to do all of the stacking tasks available through the menu interface.)

**Table 14-6. CLI Commands for Configuring Stacking on a Switch**

CLI Command	Operation
<b>show stack</b> [candidates   view   all]	<p><b>Commander:</b> Shows Commander's stacking configuration and lists the stack members and their individual status.</p> <p><b>Member:</b> Lists Member's stacking configuration and status, and the status and the IP address and subnet mask of the stack Commander.</p> <p>Options:</p> <p><b>candidates:</b> (Commander only) Lists stack Candidates.</p> <p><b>view:</b> (Commander only) Lists current stack Members and their individual status.</p> <p><b>all:</b> Lists all stack Commanders, Members and Candidates, with their individual status.</p>
<b>[no] stack</b>	<p><b>Any Stacking-Capable Switch:</b> Enables or disables stacking on the switch.</p> <p><b>Default:</b> Stacking Enabled</p>
<b>[no] stack commander &lt;stack name&gt;</b>	<p><b>Candidate or Commander:</b> Converts a Candidate to a Commander or changes the stack name of an existing commander.</p> <p><b>"No"</b> form eliminates named stack and returns Commander and stack Members to Candidate status with <b>Auto Join</b> set to <b>No</b>.</p> <p><b>"No"</b> form prevents the switch from being discovered as a stacking-capable switch.</p> <p><b>Default:</b> Switch Configured as a Candidate</p>
<b>[no] stack auto-grab</b>	<p><b>Commander:</b> Causes Commander to automatically add to its stack any discovered Candidate in the subnet that does not have a Manager password and has <b>Auto-Join</b> set to <b>Yes</b>.</p> <p><b>Default:</b> Disabled</p> <p><b>Note:</b> If the Commander's stack already has 15 members, the Candidate cannot join until an existing member leaves the stack.</p>

CLI Command	Operation
<b>[no] stack member</b> <b>&lt;switch-num&gt;</b> <b>mac-address &lt;mac-addr&gt;</b> <b>[password &lt;password-str&gt;]</b>	<b>Commander:</b> Adds a Candidate to stack membership. “No” form removes a Member from stack membership. To easily determine the MAC address of a Candidate, use the <b>show stack candidates</b> command. To determine the MAC address of a Member you want to remove, use the <b>show stack view</b> command. The password ( <i>password-str</i> ) is required only when adding a Candidate that has a Manager password.
<b>telnet &lt;1..15&gt;</b>  <i>Used In:</i> Commander Only	<b>Commander:</b> Uses the <b>SN</b> (switch number— assigned by the stack Commander) to access the console interface (menu interface or CLI) of a stack member. To view the list of <b>SN</b> assignments for a stack, execute the <b>show stack</b> command in the Commander’s CLI.
<b>[no] stack join &lt;mac-addr&gt;</b>	<b>Candidate:</b> Causes the Candidate to join the stack whose Commander has the indicated MAC address. “No” form is used in a Member to remove it from the stack of the Commander having the specified address. <b>Member:</b> “Pushes” the member to another stack whose Commander has the indicated MAC address.
<b>[no] stack auto-join</b>	<b>Candidate:</b> Enables Candidate to automatically join the stack of any Commander in the IP subnet that has <b>Auto Grab</b> enabled, or disables <b>Auto-Join</b> in the candidate.  <b>Default:</b> <b>Auto Join</b> enabled.  <b>Note:</b> If the Candidate has a Manager password or if the available stack(s) already have the maximum of 15 Members, the automatic join will not occur.
<b>stack transmission-interval</b>	<b>All Stack Members:</b> specifies the interval in seconds for transmitting stacking discovery packets.  <b>Default:</b> 60 seconds

## Using the CLI To View Stack Status

You can list the stack status for an individual switch and for other switches that have been discovered in the same subnet.

**Syntax:** show stack [candidates | view | all]

**Viewing the Status of an Individual Switch.** The following example illustrates how to use the CLI in a to display the stack status for that switch. In this case, the switch is in the default stacking configuration.

**Syntax:** show stack

```
HP4108(config)# show stack
Stacking - Stacking Status (This Switch)
Stack State           : Commander
Transmission Interval : 60
Stack Name            : Big_Waters           Number of members      : 1
Auto Grab             : Yes                 Members unreachable    : 0

SN MAC Address      System Name      Device Type  Status
-----
0  0030c1-7fcc40    HP4108         HP 4108     Commander Up
1  0030c1-7fec40    piles-1        HP 4108     Member Up
```

**Figure 14-22.** Example of Using the Show Stack Command To List the Stacking Configuration for an Individual Switch

### Viewing the Status of Candidates the Commander Has Detected.

This example illustrates how to list stack candidates the Commander has discovered in the ip subnet (broadcast domain).

**Syntax:** show stack candidates

```
HP4108(config)# show stack candidates
Stack Candidates
Candidate MAC System Name      Device Type
-----
0060b0-889e00 DEFAULT_CONFIG      HP 4000M
```

**Figure 14-23.** Example of Using the Show Stack Candidates Command To List Candidates

**Viewing the Status of all Stack-Enabled Switches Discovered in the IP Subnet.** The next example lists all the stack-configured switches discovered in the IP subnet. Because the Series 4100GL switches on which the **show stack all** command was executed is a candidate, it is included in the “Others” category.

**Syntax:** show stack all

```
HP4108(config)# show stack all

Stacking - Stacking Status (All)

Stack Name          MAC Address      System Name          Status
-----
Big_Waters          0030c1-7fcc40   HP4108;              Commander Up
                   0030c1-7fec40   Big_Waters-1         Member Up
Others:              0060b0-889e00   DEFAULT_CONFIG       Candidate
```

**Figure 14-24. Result of Using the Show Stack All Command To List Discovered Switches in the IP Subnet**

**Viewing the Status of the Commander and Current Members of the Commander’s Stack.** The next example lists all switches in the stack of the selected switch.

**Syntax:** show stack view

```
HP4108(config)# show stack view

Stack Members

SN  MAC Address      System Name          Device Type  Status
--  -
0   0030c1-7fcc40   HP4108              HP 4108     Commander Up
1   0030c1-7fec40   Big_Waters-1        HP 4108     Member Up
```

**Figure 14-25. Example of the Show Stack View Command To List the Stack Assigned to the Selected Commander**

## Using the CLI To Configure a Commander Switch

You can configure any stacking-enabled switch to be a Commander as long as the intended stack name does not already exist on the broadcast domain. (When you configure a Commander, you automatically create a corresponding stack.)

Before you begin configuring stacking parameters:

1. Configure IP addressing on the switch intended for stack commander and, if not already configured, on the primary VLAN. (For more on configuring IP addressing, see Chapter 7, “Configuring IP Addressing”.)

---

### Note

---

The primary VLAN must have an IP address in order for stacking to operate properly. For more on the primary VLAN, see “The Primary VLAN” on page 11-6.

2. Configure a Manager password on the switch intended for commander. (The Commander’s Manager password controls access to stack Members.) For more on passwords, see the local manager and operator password information in the *Access Security Guide* for your switch.

**Configure the Stack Commander.** Assigning a stack name to a switch makes it a Commander and automatically creates a stack.

**Syntax:** `stack commander <name-str>`

This example creates a Commander switch with a stack name of **Big\_Waters**. (Note that if stacking was previously disabled on the switch, this command also enables stacking.)

```
HP4108(config)# stack commander Big_Waters
```

As the following **show stack** display shows, the Commander switch is now ready to add members to the stack.

```
HP4108(config)# show stack
Stacking - Stacking Status (This Switch)
Stack State           : Commander
Transmission Interval : 60
Stack Name            : Big_Waters      Number of members      : 0
Auto Grab             : No              Members unreachable    : 0

SN MAC Address      System Name      Device Type  Status
-----
0  0030c1-b24ac0    HP 4108      HP 4108      Commander Up
```

The `stack commander` command configures the Commander and names the stack.

The Commander appears in the stack as Switch Number (SN) 0.

**Figure 14-26. Example of the Commander’s Show Stack Screen with Only the Commander Discovered**

**Using a Member’s CLI to Convert the Member to the Commander of a New Stack.** This procedure requires that you first remove the Member from its current stack, then create the new stack. If you do not know the MAC address for the Commander of the current stack, use **show stack** to list it.

**Syntax:** no stack  
stack commander <stack name>

Suppose, for example, that an HP switch named “Bering Sea” is a Member of a stack named “Big\_Waters”. To use the switch’s CLI to convert it from a stack Member to the Commander of a new stack named “Lakes”, you would use the following commands:



```

Bering Sea(config)# show stack
Stacking - Stacking Status (This Switch)

Stack State           : Member
Transmission Interval : 50
Switch Number        : 1
Stack Commander       : Big_Waters
Member Status         : Joined Successfully
Commander Status      : Commander Up
Commander IP Address  : 10.28.227.104
Commander MAC Address : 0030c1-7fc700

Bering Sea(config)# no stack join 0030c1-7fc700
Bering Sea(config)# stack name Lakes

```

The output from this command tells you the MAC address of the current stack Commander.

Removes the Member from the "Big\_Waters" stack.

Converts the former Member to the Commander of the new "Lakes" stack.

**Figure 14-27. Example of Using a Member's CLI To Convert the Member to the Commander of a New Stack**

## Adding to a Stack or Moving Switches Between Stacks

You can add switches to a stack by adding discovered Candidates or by moving switches from other stacks that may exist in the same subnet. (You cannot add a Candidate that the Commander has not discovered.)

In its default configuration, the Commander's **Auto-Grab** parameter is set to **No** to give you manual control over which switches join the stack and when they join. This prevents the Commander from automatically trying to add every Candidate it finds that has **Auto Join** set to **Yes** (the default for the Candidate).

(If you want any eligible Candidate to automatically join the stack when the Commander discovers it, configure **Auto Grab** in the Commander to **Yes**. When you do so, *any* Candidate discovered with **Auto Join** set to **Yes** (the default) and no Manager password will join the stack, up to the limit of 15 Members.)

### Using the Commander's CLI To Manually Add a Candidate to the Stack.

To manually add a candidate, you will use:

- A switch number (**SN**) to assign to the new member. Member SNs range from 1 to 15. To see which SNs are already assigned to Members, use **show stack view**. You can use any SN not included in the listing. (SNs are viewable only on a Commander switch.)
- The MAC address of the discovered Candidate you are adding to the stack. To see this data, use the **show stack candidates** listing .

For example:

```
HP4108(config)#show stack view
Stack Members
  SN MAC Address      System Name      Device Type      Status
-----
  0  0030c1-7fec40    HP4108           HP 4108          Commander Up
  1  0060b0-880a80    Indian Ocean     HP 8000M         Member Up
```

In this stack, the only SNs in use are 0 and 1, so you can use any SN number from 2 through 15 for new Members. (The SN of "0" is always reserved for the stack Commander.)

**Note:** When manually adding a switch, you must assign an SN. However, if the Commander automatically adds a new Member, it assigns an SN from the available pool of unused SNs.

Figure 14-28. Example of How To Determine Available Switch Numbers (SNs)

To display all discovered Candidates with their MAC addresses, execute **show stack candidates** from the Commander's CLI. For example, to list the discovered candidates for the above Commander:

```
HP4108(config)#show stack candidates
Stack Candidates
Candidate MAC System Name      Device Type
-----
0030c1-b24ac0 North Sea      HP 4108
0060b0-dfla00 DEFAULT_CONFIG HP 8000M
```

MAC addresses of discovered Candidates.

Figure 14-29. Example of How To Determine MAC Addresses of Discovered Candidates

Knowing the available switch numbers (**SNs**) and Candidate MAC addresses, you can proceed to manually assign a Candidate to be a Member of the stack:

**Syntax:** stack member <switch-number> mac-address <mac-addr>  
[password <password-str>]

For example, if the HP 8000M in the above listing did not have a Manager password and you wanted to make it a stack Member with an **SN** of **2**, you would execute the following command:

```
HP4108(config)# stack member 2 mac-address 0060b0-dfla00
```

The **show stack view** command then lists the Member added by the above command:

```
HP4108(config)# show stack view
Stack Members
  SN MAC Address      System Name      Device Type      Status
  ---
  0  0030c1-7fec40    HP2512          HP 4108         Commander Up
  1  0060b0-880a80    Indian Ocean    HP 8000M        Member Up
  2  0060b0-dfla00    Big_Waters-2    HP 8000M        Member Up
```

SN (Switch Number) 2 is the new Member added by the **stack member** command.

The new member did not have a System Name configured prior to joining the stack, and so receives a System Name composed of the stack name (assigned in the Commander) with its SN number as a suffix.

**Figure 14-30. Example Showing the Stack After Adding a New Member**

**Using Auto Join on a Candidate.** In the default configuration, a Candidate’s Auto Join parameter is set to “Yes”, meaning that it will automatically join a stack if the stack’s Commander detects the Candidate and the Commander’s Auto Grab parameter is set to “Yes”. You can disable Auto Join on a Candidate if you want to prevent automatic joining in this case. There is also the instance where a Candidate’s Auto Join is disabled, for example, when a Commander leaves a stack and its members automatically return to Candidate status, or if you manually remove a Member from a stack. In this case, you may want to reset Auto Join to “Yes”.

**Status:** [no] stack auto-join

```
HP4108(config)# no stack auto-join Disables Auto Join on a Candidate.
```

```
HP4108(config)# stack auto-join Enables Auto Join on a Candidate.
```

**Using a Candidate CLI To Manually “Push” the Candidate Into a Stack .** Use this method if any of the following apply:

- The Candidate's **Auto Join** is set to **Yes** (and you do not want to enable **Auto Grab** on the Commander) or the Candidate's **Auto Join** is set to **No**.
- Either you know the MAC address of the Commander for the stack into which you want to insert the Candidate, or the Candidate has a valid IP address and is operating in your network.

**Syntax:** stack join <mac-addr>

where: <mac-addr> is the MAC address of the Commander in the destination stack.

Use Telnet (if the Candidate has an IP address valid for your network) or a direct serial port connection to access the CLI for the Candidate switch. For example, suppose that a Candidate named “North Sea” with **Auto Join** off and a valid IP address of 10.28.227.104 is running on a network. You could Telnet to the Candidate, use **show stack all** to determine the Commander's MAC address, and then “push” the Candidate into the desired stack.

The screenshot shows a sequence of CLI commands and their output. Annotations 1-4 point to specific steps: 1. Telnet to the Candidate named "North Sea". 2. Use show stack all to display the Commander's MAC address. 3. Set the Candidate CLI to Config mode. 4. Execute stack join with the Commander's MAC address to "push" the Candidate into the stack.

```
HP4108# telnet 10.28.227.104
North Sea# show stack all
Stacking - Stacking Status (All)
-----
Stack Name      MAC Address      System Name      Status
-----
Big_Waters      0030c1-7fec40    HP4108           Commander Up
                 0060b0-880a80    Indian Ocean     Member Up
                 0060b0-df1a00    Bering Sea       Member Up
Others:         0030c1-7fc700    North Sea        Candidate

North Sea# config
North Sea(config)# stack join 0030c1-7fec40
```

Figure 14-31. Example of “Pushing” a Candidate Into a Stack

To verify that the Candidate successfully joined the stack, execute **show stack all** again to view the stacking status.

**Using the Destination Commander CLI To “Pull” a Member from Another Stack.** This method uses the Commander in the destination stack to “pull” the Member from the source stack.

**Syntax:** stack member <switch-number>  
mac-address <mac-addr>  
[password<password-str>]

In the destination Commander, use **show stack all** to find the MAC address of the Member you want to pull into the destination stack. For example, suppose you created a new Commander with a stack name of “Cold\_Waters” and you wanted to move a switch named “Bering Sea” into the new stack:

```
HP4108(config)# show stack all
Stacking - Stacking Status (All)
Stack Name      MAC Address      System Name      Status
-----
Big_Waters      0030c1-7fec40    HP4108           Commander Up
                 0060b0-880a80    Indian Ocean     Member Up
                 0060b0-df1a00    Bering Sea      Member Up
Cold_Waters     0030c1-7fc700    HP4108           Commander Up
```

Move this switch into the “Cold Waters” stack.

**Figure 14-32. Example of Stack Listing with Two Stacks in the Subnet**

You would then execute the following command to pull the desired switch into the new stack:

```
HP4108(config)# stack member 1 mac-address 0060b0-df1a00
```

Where **1** is an unused switch number (**SN**).

Since a password is not set on the Candidate, a password is not needed in this example.

You could then use **show stack all** again to verify that the move took place.

**Using a Member CLI To “Push” the Member into Another Stack.** You can use the Member’s CLI to “push” a Series 4100GL switches stack Member into a destination stack if you know the MAC address of the destination Commander.

**Syntax:** stack join <mac-addr>

where: <mac-addr> is the MAC address of the Commander for the destination stack.

**Converting a Commander to a Member of Another Stack.** Removing the Commander from a stack eliminates the stack and returns its Members to the Candidate pool with **Auto Join** disabled.

**Syntax:** no stack name <stack name>  
stack join <mac-address>

If you don't know the MAC address of the destination Commander, you can use **show stack all** to identify it.

For example, suppose you have a Series 4100GL switch operating as the Commander for a temporary stack named "Test". When it is time to eliminate the temporary "Test" stack and convert the Series 4100GL switch into a member of an existing stack named "Big\_Waters", you would execute the following commands in the CLI of the Series 4100GL switch:

```
HP4108 (config)# no stack name Test
HP4108 (config)# show stack all
Stacking - Stacking Status (All)
Stack Commander  MAC Address  System Name  Status
-----
Big_Waters       0030c1-7fc700 HP4108       Commander Up
                  0060b0-889e00 Big_Waters-1 Member Up
Others:          0030c1-7fec40 HP4108       Candidate
HP4108 (config)# stack join 0030c1-7fc700
```

Eliminates the "Test" stack and converts the Commander to a Candidate.

Helps you to identify the MAC address of the Commander for the "Big\_Waters" stack.

Adds the former "Test" Commander to the "Big\_Waters" stack.

Figure 14-33. Example of Command Sequence for Converting a Commander to a Member

### Using the CLI To Remove a Member from a Stack

You can remove a Member from a stack using the CLI of either the Commander or the Member.

---

#### Note

When you remove a Member from a stack, the Member's **Auto Join** parameter is set to **No**.

**Using the Commander CLI To Remove a Stack Member.** This option requires the switch number (SN) and the MAC address of the switch to remove. (Because the Commander propagates its Manager password to all stack members, knowing the Manager password is necessary only for gaining access to the Commander.)

**Syntax:** [no] stack member <switch-num> mac-address <mac-addr>

Use **show stack view** to list the stack Members. For example, suppose that you wanted to use the Commander to remove the “North Sea” Member from the following stack:

	SN	MAC Address	System Name	Device Type	Status
	0	0030c1-7fec40	HP4108	HP 4108	Commander Up
	1	0060b0-880a80	Indian Ocean	HP 8000M	Member Up
	2	0060b0-df1a00	Bering Sea	HP 8000M	Member Up
	3	0030c1-7fc700	North Sea	HP 4108	Member Up

HP4108 (config)# show stack view  
Stack Members

Remove this Member from the stack. →

**Figure 14-34. Example of a Commander and Three Switches in a Stack**

You would then execute this command to remove the “North Sea” switch from the stack:

```
HP4108 (config) # no stack member 3 mac-address 0030c1-7fc700
```

where:

- **3** is the “North Sea” Member’s switch number (**SN**)
- **0030c1-7fc700** is the “North Sea” Member’s MAC address

#### Using the Member’s CLI To Remove the Member from a Stack.

**Syntax:** no stack join <mac-addr>

To use this method, you need the Commander’s MAC address, which is available using the show stack command in the Member’s CLI. For example:

CLI for “North Sea” Stack Member →	North Sea(config)# show stack
	Stacking - Stacking Status (This Switch)
	Stack State : Member
	Transmission Interval : 10
	Switch Number : 3
	Stack Name : Big_Waters
	Member Status : Joined Successfully
	Commander Status : Commander Up
	Commander IP Address : 11.28.227.103
MAC Address of the Commander for the Stack to Which the “North Sea” Switch Belongs →	Commander MAC Address : 0030c1-7fec40

**Figure 14-35. Example of How To Identify the Commander’s MAC Address from a Member Switch**

You would then execute this command in the “North Sea” switch’s CLI to remove the switch from the stack:

```
North Sea(config)# no stack join 0030c1-7fec40
```

## Using the CLI To Access Member Switches for Configuration Changes and Traffic Monitoring

After a Candidate becomes a Member, you can use the telnet command from the Commander to access the Member’s CLI or console interface for the same configuration and monitoring that you would do through a Telnet or direct-connect access from a terminal.

**Syntax:** telnet <switch-number>

*where:* unsigned integer is the switch number (**SN**) assigned by the Commander to each member (range: **1 - 15**).

To find the switch number for the Member you want to access, execute the **show stack view** command in the Commander’s CLI. For example, suppose that you wanted to configure a port trunk on the switch named “North Sea” in the stack named “Big\_Waters”. Do do so you would go to the CLI for the “Big\_Waters” Commander and execute show stack view to find the switch number for the “North Sea” switch:

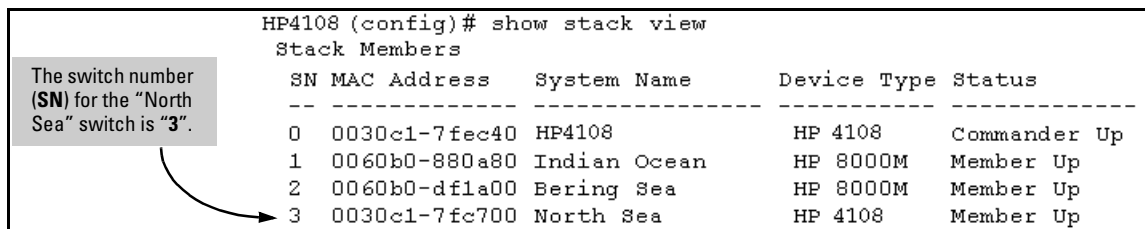

```
HP4108 (config)# show stack view
Stack Members
  SN  MAC Address      System Name      Device Type      Status
  ---  -
  0    0030c1-7fec40      HP4108           HP 4108          Commander Up
  1    0060b0-880a80      Indian Ocean     HP 8000M         Member Up
  2    0060b0-df1a00      Bering Sea       HP 8000M         Member Up
  3    0030c1-7fc700      North Sea        HP 4108          Member Up
```

The switch number (SN) for the “North Sea” switch is “3”.

**Figure 14-36. Example of a Stack Showing Switch Number (SN) Assignments**

To access the “North Sea” console, you would then execute the following **telnet** command:

```
HP4108 (config) # telnet 3
```

You would then see the CLI prompt for the “North Sea” switch, allowing you to configure or monitor the switch as if you were directly connected to the console.



## SNMP Community Operation in a Stack

### Community Membership

In the default stacking configuration, when a Candidate joins a stack, it automatically becomes a Member of any SNMP community to which the Commander belongs, even though any community names configured in the Commander are not propagated to the Member's SNMP Communities listing. However, if a Member has its own (optional) IP addressing, it can belong to SNMP communities to which other switches in the stack, including the Commander, do not belong. For example:

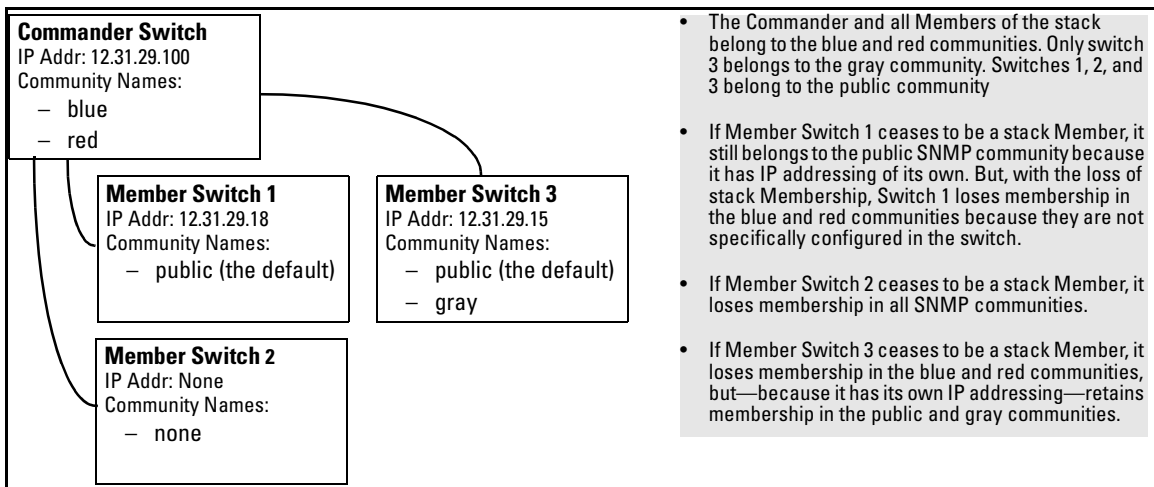

**Figure 14-37. Example of SNMP Community Operation with Stacking**

### SNMP Management Station Access to Members Via the Commander.

To use a management station for SNMP Get or Set access through the Commander's IP address to a Member, you must append **@sw<switch number>** to the community name. For example, in figure 14-37, you would use the following command in your management station to access Switch 1's MIB using the blue community:

```
snmpget <MIB variable> 10.31.29.100 blue@sw1
```

Note that because the gray community is only on switch 3, you could not use the Commander IP address for gray community access from the management station. Instead, you would access switch 3 directly using the switch's own IP address. For example:

```
snmpget <MIB variable> 10.31.29.15 gray
```

Note that in the above example (figure 14-37) you cannot use the public community through the Commander to access any of the Member switches. For example, you can use the public community to access the MIB in switches 1 and 3 by using their unique IP addresses. However, you must use the red or blue community to access the MIB for switch 2.

```
snmpget <MIB variable> 10.31.29.100 blue@sw2
```

## Using the CLI To Disable or Re-Enable Stacking

In the default configuration, stacking is enabled on the Procurve Series 4100GL switches. You can use the CLI to disable stacking on these switches at any time. Disabling stacking has the following effects:

- **Disabling a Commander:** Eliminates the stack, returns the stack Members to Candidates with **Auto Join** disabled, and changes the Commander to a stand-alone (nonstacking) switch. You must re-enable stacking on the switch before it can become a Candidate, Member, or Commander.
- **Disabling a Member:** Removes the Member from the stack and changes it to a stand-alone (nonstacking) switch. You must re-enable stacking on the switch before it can become a Candidate, Member, or Commander.
- **Disabling a Candidate:** Changes the Candidate to a stand-alone (nonstacking) switch.

**Syntax:**    no stack    (Disables stacking on the switch.)  
              stack        (Enables stacking on the switch.)

## Transmission Interval

All switches in the stack must be set to the same transmission interval to help ensure proper stacking operation. HP recommends that you leave this parameter set to the default 60 seconds.

**Syntax:**    stack transmission-interval <seconds>

## Stacking Operation with Multiple VLANs Configured

Stacking uses the primary VLAN in a switch. In the factory-default configuration, the DEFAULT\_VLAN is the primary VLAN. However, you can designate any VLAN configured in the switch as the primary VLAN. (See “The Primary VLAN” on page 11-6.)

When using stacking in a multiple-VLAN environment, the following criteria applies:

- Stacking uses only the primary VLAN on each switch in a stack.
- The primary VLAN can be tagged or untagged as needed in the stacking path from switch to switch.
- The same VLAN ID (VID) must be assigned to the primary VLAN in each stacked switch.

## Web: Viewing and Configuring Stacking

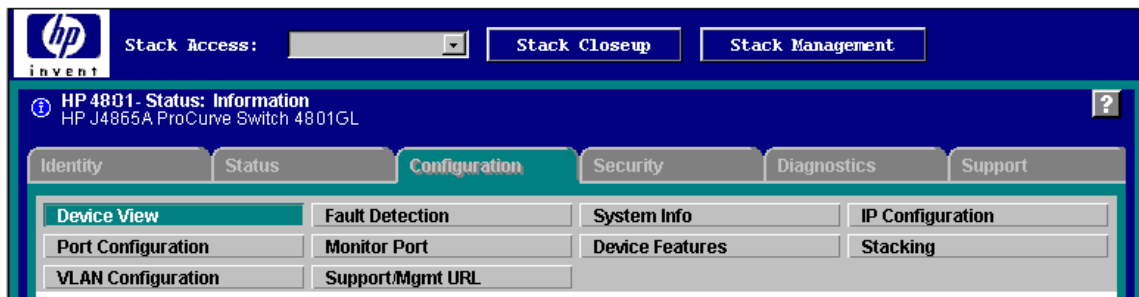

Figure 14-38. Example of the Web Browser Interface for a Commander

The web browser interface for a Commander appears as shown above. The interface for Members and Candidates appears the same as for a non-stacking Series 4100GL switches.

To view or configure stacking on the web browser interface:

1. Click on the **Configuration** tab.
2. Click on [Stacking](#) to display the stacking configuration for an individual switch, and make any configuration changes you want for that switch.
3. Click on [Apply Changes](#) to save any configuration changes for the individual switch.
4. If the switch is a Commander, use the [Stack Closeup](#) and [Stack Management](#) buttons for viewing and using stack features.

To access the web-based Help provided for the switch, click on [?](#) in the web browser screen.

## Status Messages

Stacking screens and listings display these status messages:

Message	Condition	Action or Remedy
Candidate Auto-join	Indicates a switch configured with Stack State set to <b>Candidate, Auto Join</b> set to <b>Yes</b> (the default), and no Manager password.	None required
Candidate	Candidate cannot automatically join the stack because one or both of the following conditions apply: <ul style="list-style-type: none"><li>• Candidate has <b>Auto Join</b> set to <b>No</b>.</li><li>• Candidate has a Manager password.</li></ul>	Manually add the candidate to the stack.
Commander Down	Member has lost connectivity to its Commander.	Check connectivity between the Commander and the Member.
Commander Up	The Member has stacking connectivity with the Commander.	None required.
Mismatch	This may be a temporary condition while a Candidate is trying to join a stack. If the Candidate does not join, then stack configuration is inconsistent.	Initially, wait for an update. If condition persists, reconfigure the Commander or the Member.
Member Down	A Member has become detached from the stack. A possible cause is an interruption to the link between the Member and the Commander.	Check the connectivity between the Commander and the Member.
Member Up	The Commander has stacking connectivity to the Member.	None required.
Rejected	The Candidate has failed to be added to the stack.	The candidate may have a password. In this case, manually add the candidate. Otherwise, the stack may already be full. A stack can hold up to 15 Members (plus the Commander).

# File Transfers

---

## Contents

<b>Overview</b> .....	A-2
<b>Downloading an Operating System (OS)</b> .....	A-2
General OS Download Rules .....	A-2
Using TFTP To Download an OS Image from a Server .....	A-3
Menu: TFTP Download from a Server to Primary Flash .....	A-4
CLI: TFTP Download from a Server to Primary or Secondary Flash .....	A-5
Using Xmodem to Download an OS Image From a PC or UNIX Workstation .....	A-6
Menu: Xmodem Download to Primary Flash .....	A-7
CLI: Xmodem Download from a PC or Unix Workstation to Primary or Secondary Flash .....	A-8
Switch-to-Switch Download .....	A-9
Menu: Switch-to-Switch Download to Primary Flash .....	A-9
CLI: Switch-To-Switch Downloads .....	A-10
Using the HP TopTools for Hubs & Switches Utility .....	A-11
<b>Troubleshooting TFTP Downloads</b> .....	A-12
<b>Transferring Switch Configurations</b> .....	A-13
<b>Copying Diagnostic Data to a Remote Host, PC, or Unix     Workstation</b> .....	A-16
Copying Command Output to a Destination Device .....	A-16
Copying Event Log Output to a Destination Device .....	A-17
Copying Crash Data Content to a Destination Device .....	A-17
Copying Crash Log Data Content to a Destination Device ....	A-18

## Overview

You can download new switch software (operating system—OS) and upload or download switch configuration files. These features are useful for acquiring periodic switch software upgrades and for storing or retrieving a switch configuration.

This appendix includes the following information:

- Downloading an operating system (begins below)
- Transferring switch configurations (begins on page A-13)

For information on how switch memory operates, including primary and secondary flash, see Chapter 5, “Switch Memory and Configuration”.

---

## Downloading an Operating System (OS)

HP periodically provides switch operating system (OS) updates through the HP Procurve website (<http://www.hp.com/go/hpprocurve>). For more information, see the support and warranty booklet shipped with the switch. After you acquire a new OS file, you can use one of the following methods for downloading the operating system (OS) code to the switch:

### OS Download Features

Feature	Default	Menu	CLI	Web
TFTP	n/a	page A-4	page A-5	—
Xmodem	n/a	page A-7	page A-8	—
Switch-to-Switch	n/a	page A-9	page A-10	
SNMP Download Manager in HP TopTools for Hubs & Switches	Refer to the documentation provided with HP TopTools for Hubs and Switches			

### General OS Download Rules

- An OS image you download via the menu interface always goes to primary flash.
  - After an OS download, you must reboot the switch to implement the newly downloaded OS. Until a reboot occurs, the switch continues to run on the OS it was using before the download commenced.
-

---

**Note**

Downloading a new OS does not change the current switch configuration. The switch configuration is contained in separate files that can also be transferred. See “Transferring Switch Configurations” on page A-13.

In most cases, if a power failure or other cause interrupts a flash image download, the switch reboots with the image previously stored in primary flash. In the unlikely event that the primary image is corrupted (which may occur if a download is interrupted by a power failure), the switch goes into boot ROM mode. In this case, use the boot ROM console to download a new image to primary flash. See “Restoring a Flash Image” on page C-35.

---

## Using TFTP To Download an OS Image from a Server

This procedure assumes that:

- An OS file for the switch has been stored on a TFTP server accessible to the switch. (The OS file is typically available from the HP Procurve website at <http://www.hp.com/go/hpprocurve>.)
- The switch is properly connected to your network and has already been configured with a compatible IP address and subnet mask.
- The TFTP server is accessible to the switch via IP.

Before you use the procedure, do the following:

- Obtain the IP address of the TFTP server in which the OS file has been stored.
- If VLANs are configured on the switch, determine the name of the VLAN in which the TFTP server is operating.
- Determine the name of the OS file stored in the TFTP server for the switch (for example, G0101.swi).

---

**Note**

If your TFTP server is a Unix workstation, *ensure that the case (upper or lower) that you specify for the filename is the same case as the characters in the OS filenames on the server.*

---

## Menu: TFTP Download from a Server to Primary Flash

Note that the menu interface accesses only the primary flash.

1. In the console Main Menu, select **Download OS** to display this screen:

```
----- CONSOLE - MANAGER MODE -----  
Download OS  
  
Current Firmware revision : G.05.01  
  
Method [TFTP] : TFTP  
TFTP Server :  
  
Remote File Name :  
  
Actions->  _Cancel      _Edit      eXecute      _Help  
  
Select the file transfer method (TFTP and XMODEM are currently supported).  
Use arrow keys to change field selection, <Space> to toggle field choices,  
and <Enter> to go to Actions.
```

**Figure A-1. Example of the Download OS Screen (Default Values)**

2. Press **[E]** (for **Edit**).
3. Ensure that the **Method** field is set to **TFTP** (the default).
4. In the **TFTP Server** field, type in the IP address of the TFTP server in which the OS file has been stored.
5. In the **Remote File Name** field, type the name of the OS file. If you are using a UNIX system, remember that the filename is case-sensitive.
6. Press **[Enter]**, then **[X]** (for **eXecute**) to begin the OS download. The following screen then appears:

```
----- CONSOLE - MANAGER MODE -----  
Download OS  
  
Current Firmware revision : G.05.01  
Method [TFTP] : TFTP  
TFTP Server : 13.28.227.105  
  
Remote File Name : G_05_02.swi  
  
Received 370,000 bytes of OS download.  
+-----+  
|*****|  
+-----+
```

**Figure A-2. Example of the Download OS Screen During a Download**



A “progress” bar indicates the progress of the download. When the entire OS file has been received, all activity on the switch halts and you will see **Validating and writing system software to FLASH...**

7. After the primary flash memory has been updated with the new operating system, you must reboot the switch to implement the newly downloaded OS. Return to the Main Menu and press **[6]** (for **Reboot Switch**). You will then see this prompt:

```
Continue reboot of system? : No
```

Press the space bar once to change No to Yes, then press **[Enter]** to begin the reboot.

---

**Note**

---

When you use the menu interface to download an OS, the new image is always stored in primary flash. Also, using the Reboot Switch command in the Main Menu always reboots the switch from primary flash. Rebooting the switch from the CLI gives you more options. See “Rebooting the Switch” on page 5-17.

8. After you reboot the switch, confirm that the operating system downloaded correctly:
  - a. From the Main Menu, select **1. Status and Counters**, and from the Status and Counters menu, select **1. General System Information**
  - b. Check the **Firmware revision** line.

### CLI: TFTP Download from a Server to Primary or Secondary Flash

This command automatically downloads an OS image to primary or secondary flash.

**Syntax:** `copy tftp flash <ip-address> <remote-os-file> [< primary | secondary >]`

Note that if you do not specify the flash destination, the Xmodem download defaults to primary flash.

For example, to download an OS file named G0502.swi from a TFTP server with the IP address of 10.28.227.103 to primary flash:

1. Execute **copy** as shown below:

```
HPswitch# copy tftp flash 10.28.227.103 g0502.swi
The Primary OS Image will be deleted, continue [y/n]? y
01431K
```

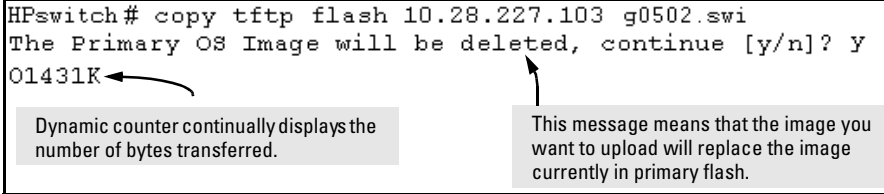

Dynamic counter continually displays the number of bytes transferred.

This message means that the image you want to upload will replace the image currently in primary flash.

**Figure A-3. Example of the Command to Download an OS**

2. When the switch finishes downloading the OS file from the server, it displays this progress message:

#### **Validating and Writing System Software to FLASH . . .**

3. When the switch is ready to activate the downloaded software you will see this message:

**System software written to FLASH.**

**You will need to reboot to activate.**

At this point, use the boot command to reboot the switch and activate the software you just downloaded:

```
HPswitch # boot
```

(For more on these commands, see “Rebooting the Switch” on page 5-17.)

4. To confirm that the operating system downloaded correctly, execute **show system** and check the Firmware revision line.

If you need information on primary/secondary flash memory and the boot commands, see “Using Primary and Secondary Flash Image Options” on page 5-12.

## Using Xmodem to Download an OS Image From a PC or UNIX Workstation

This procedure assumes that:

- The switch is connected via the Console RS-232 port to a PC operating as a terminal. (Refer to the *Installation and Getting Started Guide* you received with the switch for information on connecting a PC as a terminal and running the switch console interface.)
- The switch operating system (OS) is stored on a disk drive in the PC.

- The terminal emulator you are using includes the Xmodem binary transfer feature. (For example, in the HyperTerminal application included with Windows NT, you would use the **Send File** option in the **Transfer** dropdown menu.)

## Menu: Xmodem Download to Primary Flash

Note that the menu interface accesses only the primary flash.

1. From the console Main Menu, select  
**7. Download OS**
2. Press **[E]** (for **E**dit).
3. Use the Space bar to select **XMODEM** in the **Method** field.
4. Press **[Enter]**, then **[X]** (for **eXecute**) to begin the OS download. The following message then appears:

**Press enter and then initiate Xmodem transfer  
from the attached computer....**

5. Press **[Enter]** and then execute the terminal emulator command(s) to begin Xmodem binary transfer. For example, using HyperTerminal:
  - a. Click on **Transfer**, then **Send File**.
  - b. Type the file path and name in the Filename field.
  - c. In the Protocol field, select **Xmodem**.
  - d. Click on the **[Send]** button.

The download will then commence. It can take several minutes, depending on the baud rate set in the switch and in your terminal emulator.

6. After the primary flash memory has been updated with the new operating system, you must reboot the switch to implement the newly downloaded OS. Return to the Main Menu and press **[6]** (for **Reboot Switch**). You will then see this prompt:

```
Continue reboot of system? : No
```

Press the space bar once to change No to Yes, then press **[Enter]** to begin the reboot.

7. To confirm that the operating system downloaded correctly:
  - a. From the Main Menu, select  
**1. Status and Counters**  
**1. General System Information**
  - b. Check the **Firmware revision** line.

## CLI: Xmodem Download from a PC or Unix Workstation to Primary or Secondary Flash

Using Xmodem and a terminal emulator, you can download an OS image to either primary or secondary flash.

**Syntax:** copy xmodem flash [<primary | secondary>]

Note that if you do not specify the flash destination, the Xmodem download defaults to primary flash.

For example, to download an OS file named G0103.swi from a PC (running a terminal emulator program such as HyperTerminal) to primary flash:

1. Execute the following command in the CLI:

```
HPswitch# copy xmodem flash
The Primary OS Image will be deleted, continue [y/n]? y
Press 'Enter' and start XMODEM on your host...
```

2. Execute the terminal emulator commands to begin the Xmodem transfer. For example, using HyperTerminal:
  - a. Click on **Transfer**, then **Send File**.
  - b. Type the file path and name in the Filename field.
  - c. In the Protocol field, select **Xmodem**.
  - d. Click on the  button.

The download can take several minutes, depending on the baud rate used in the transfer.

3. When the download finishes, you must reboot the switch to implement the newly downloaded OS. To do so, use one of the following commands:

boot system flash <primary | secondary>Reboots from the selected flash.

-or-

reload Reboots from the flash image currently in use.

(For more on these commands, see “Rebooting the Switch” on page 5-17.)

4. To confirm that the operating system downloaded correctly:

```
HPswitch> show system
```

Check the **Firmware revision** line. It should show the OS version that you downloaded in the preceding steps.

If you need information on primary/secondary flash memory and the boot commands, see “Using Primary and Secondary Flash Image Options” on page 5-12.

## Switch-to-Switch Download

You can use TFTP to transfer an OS image between two Series 4100GL switches. The menu interface enables you to transfer primary-to-primary or secondary-to-primary. The CLI enables all combinations of flash location options.

### Menu: Switch-to-Switch Download to Primary Flash

Using the menu interface, you can download an OS from either the primary or secondary flash of one Series 4100GL switches to the primary flash of another Series 4100GL switches.

1. From the switch console Main Menu in the switch to receive the download, select **7. Download OS** screen.
2. Ensure that the **Method** parameter is set to **TFTP** (the default).
3. In the **TFTP Server** field, enter the IP address of the remote Series 4100GL switches containing the OS you want to download.
4. For the **Remote File Name**, enter one of the following:
  - To download the OS in the primary flash of the source switch, type “**flash**” in lowercase characters.
  - To download the OS in the secondary flash of the source switch, type **/os/secondary**.
5. Press , then  (for **eXecute**) to begin the OS download.
6. A “progress” bar indicates the progress of the download. When the entire operating system has been received, all activity on the switch halts and the following messages appear:

**Validating and writing system software to FLASH...**

7. After the primary flash memory has been updated with the new operating system, you must reboot the switch to implement the newly downloaded OS. Return to the Main Menu and press  (for **Reboot Switch**). You will then see this prompt:

```
Continue reboot of system? : No
```

Press the space bar once to change No to Yes, then press  to begin the reboot.

8. To confirm that the operating system downloaded correctly:

- a. From the Main Menu, select

**Status and Counters**

**General System Information**

- b. Check the **Firmware revision** line.

### CLI: Switch-To-Switch Downloads

You can download an OS image between two Series 4100GL switchess connected on your LAN by initiating a **copy tftp** command from the destination switch. The options for this CLI feature include:

- Copy from primary flash in the source to either primary or secondary in the destination.
- Copy from either primary or secondary flash in the source to either primary or secondary flash in the destination.

**Downloading from Primary Only.** This command (executed in the destination switch) downloads the OS flash in the source switch's primary flash to either the primary or secondary flash in the destination switch.

**Syntax:** `copy tftp flash <ip-addr> flash [primary | secondary]`

If you do not specify either a primary or secondary flash location for the destination, the download automatically goes to primary flash.

For example, to download an OS file from primary flash in a Series 4100GL switches with an IP address of 10.28.227.103 to the primary flash in the destination switch, you would execute the following command in the destination switch's CLI:

```
HPswitch# copy tftp flash 10.29.227.103 flash
Device will be rebooted, do you want to continue [y/n] Y
00107K
```

Running Total of Bytes Downloaded

**Figure A-4. Switch-To-Switch, from Primary in Source to Either Flash in Destination**

**Downloading from Either Flash in the Source Switch to Either Flash in the Destination Switch.** This command (executed in the destination switch) gives you the most options for downloading between switches.

**Syntax:** `copy tftp flash <ip-addr> </os/primary> | </os/secondary> [primary | secondary]`

If you do not specify either a primary or secondary flash location for the destination, the download automatically goes to primary flash.

For example, to download an OS file from secondary flash in a Series 4100GL switches with an IP address of 10.28.227.103 to the secondary flash in the destination switch, you would execute the following command in the destination switch's CLI:

```
HPswitch# copy tftp flash 10.29.227.103 /os/secondary secondary  
Device will be rebooted, do you want to continue [y/n] Y  
01084K
```

**Figure A-5. Switch-to-Switch, from Either Flash in Source to Either Flash in Destination**

## Using the HP TopTools for Hubs & Switches Utility

HP TopTools for Hubs & Switches includes a software update utility for updating on HP ProCurve switch products such as the Series 4100GL switches. For further information, refer to the *HP TopTools for Hubs & Switches User Guide*, provided electronically with the HP TopTools software.

## Troubleshooting TFTP Downloads

When using the menu interface, if a TFTP download fails, the Download OS screen indicates the failure.

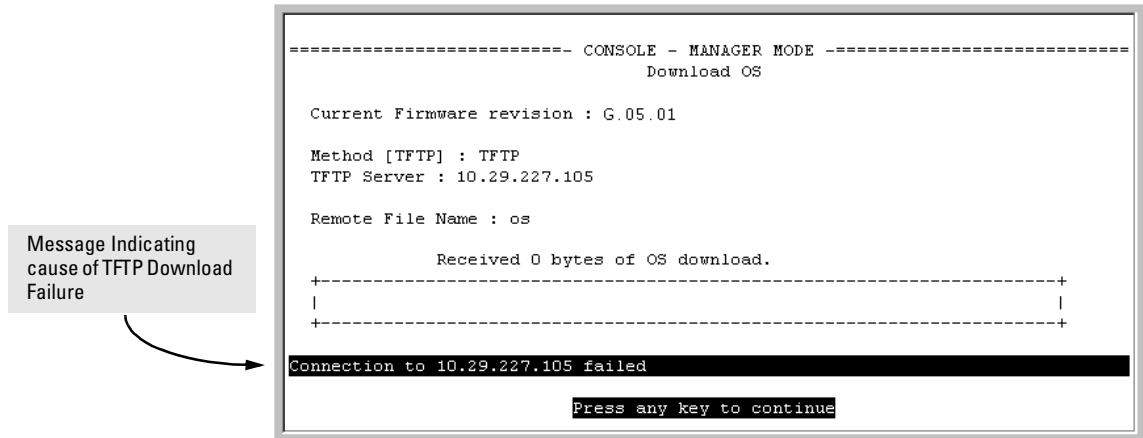

**Figure A-6. Example of Message for Download Failure**

To find more information on the cause of a download failure, examine the messages in the switch's Event Log by executing this CLI command:

```
HPswitch# show log tftp
```

(For more on the Event Log, see "Using the Event Log To Identify Problem Sources" on page C-21.)

Some of the causes of download failures include:

- Incorrect or unreachable address specified for the **TFTP Server** parameter. This may include network problems.
- Incorrect VLAN.
- Incorrect name specified for the **Remote File Name** parameter, or the specified file cannot be found on the TFTP server. This can also occur if the TFTP server is a Unix machine and the case (upper or lower) for the filename on the server does not match the case for the filename entered for the **Remote File Name** parameter in the Download OS screen.
- One or more of the switch's IP configuration parameters are incorrect.



- For a Unix TFTP server, the file permissions for the OS file do not allow the file to be copied.
- Another console session (through either a direct connection to a terminal device or through Telnet) was already running when you started the session in which the download was attempted.

---

**Note**

---

If an error occurs in which normal switch operation cannot be restored, the switch automatically reboots itself. In this case, an appropriate message is displayed after the switch reboots.

---

## Transferring Switch Configurations

### Transfer Features

Feature	Default	Menu	CLI	Web
use TFTP to copy from a remote host to a config file	n/a	—	below	—
use TFTP to copy a config file to a remote host	n/a	—	page A-14	—
use Xmodem to copy a configuration from a serially connected host to a config file	n/a	—	page A-14	—
Use Xmodem to copy a config file to a serially connected host	n/a	—	page A-15	—

Using the CLI commands described in this section, you can copy switch configurations to and from a switch.

### **TFTP: Copying a Configuration from a Remote Host.**

**Syntax:**    `copy tftp <startup-config | running-config><ip-address> <remote-file>`

This command copies a configuration from a remote host to the startup-config file in the switch. (See Chapter 5, “Using Primary and Secondary Flash Image Options” for information on the startup-config file.)

For example, to download a configuration file named **sw4100** in the **configs** directory on drive "d" in a remote host having an IP address of 10.28.227.105:

```
HPswitch# copy tftp startup-config 10.28.227.105
          d:\configs\sw4100
```

**TFTP: Copying a Configuration File to a Remote Host.**

**Syntax:** copy <startup-config | running-config> tftp <ip-addr> <remote-file>

This command copies the switch's startup configuration (startup-config file) to a remote TFTP host.

For example, to upload the current startup configuration to a file named **sw4100** in the configs directory on drive "d" in a remote host having an IP address of 10.28.227.105:

```
HPswitch# copy startup-config tftp 10.28.227.105
          d:\configs\sw4100
```

**Xmodem: Copying a Configuration File from the Switch to a Serially Connected PC or Unix Workstation.** To use this method, the switch must be connected via the serial port to a PC or Unix workstation to which you want to copy the configuration file. You will need to:

- Determine a filename to use.
- Know the directory path you will use to store the the configuration file.

**Syntax:** copy <startup-config | running-config> xmodem <pc | unix>

For example, to copy a configuration file to a PC serially connected to the switch:

1. Determine the file name and directory location on the PC.
2. Execute the following command:

```
HP4108# copy startup-config xmodem pc
Press 'Enter' and start XMODEM on your host...
```

3. After you see the above prompt, press **Enter**.
4. Execute the terminal emulator commands to begin the file transfer.

**Xmodem: Copying a Configuration File from a Serially Connected PC or Unix Workstation.** To use this method, the switch must be connected via the serial port to a PC or Unix workstation on which is stored the configuration file you want to copy. To complete the copying, you will need to know the name of the file to copy and the drive and directory location of the file.

**Syntax:**    copy xmodem startup-config <pc | unix>

For example, to copy a configuration file from a PC serially connected to the switch:

1. Execute the following command:

```
HPswitch# copy xmodem startup-config pc
Device will be rebooted, do you want to continue [y/n]? y
Press 'Enter' and start XMODEM on your host...
```

2. After you see the above prompt, press `Enter`.
3. Execute the terminal emulator commands to begin the file transfer.
4. When the download finishes, you must reboot the switch to implement the newly downloaded OS. To do so, use one of the following commands:

boot system flash <primary | secondary> Reboots from the selected  
flash.

-or-

reload                                    Reboots from the flash image  
    currently in use.

(For more on these commands, see “Rebooting the Switch” on page 5-17.)

## Copying Diagnostic Data to a Remote Host, PC, or Unix Workstation

You can use the CLI to copy the following types of switch data to a text file in a management device:

- **Command Output:** Sends the output of a switch CLI command as a file on the destination device.
- **Event Log:** Copies the switch's Event Log into a file on the destination device.
- **Crash Data:** OS-specific data useful for determining the reason for a system crash.
- **Crash Log:** Processor-Specific operating data useful for determining the reason for a system crash.

### Copying Command Output to a Destination Device

This command directs the displayed output of a CLI command to a file in a destination device.

**Syntax:**     `copy command-output <"cli-command"> tftp <ip-address>  
                  <filepath-filename>`

`copy command-output <"cli-command"> xmodem`

For example, to use Xmodem to copy the output of **show config** to a serially connected PC:

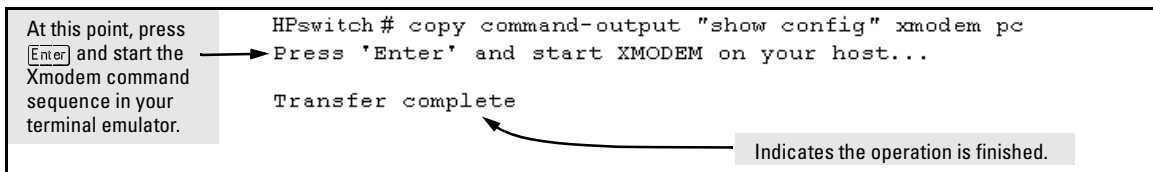

**Figure A-7. Example of Sending Command Output to a File on an Attached PC**

Note that the command you specify must be enclosed in double-quote marks.

## Copying Event Log Output to a Destination Device

This command uses TFTP or Xmodem to copy the Event Log content to a PC or UNIX workstation on the network.

**Syntax:**   copy event-log tftp <ip-address> <filepath and filename>  
                   copy event-log xmodem

For example, to copy the event log to a PC connected to the switch:

At this point, press <b>Enter</b> and start the Xmodem command sequence in your terminal emulator.	<pre> HPswitch# copy event-log xmodem pc Press 'Enter' and start XMODEM on your host...  Transfer complete </pre>
--	---

**Figure A-8. Example of Sending Event Log Content to a File on an Attached PC**

## Copying Crash Data Content to a Destination Device

This command uses TFTP or Xmodem to copy the Crash Data content to a PC or UNIX workstation on the network. You can copy individual slot information or the master switch information. If you do not specify either, the command defaults to the master data.

**Syntax:**   copy crash-data [<slot-id | master>] xmodem  
                   copy crash-data [<slot-id | master>] tftp <ip-address> <filename>

where:   slot-id = **a - h**, and retrieves the crash log or crash data from the processor on the module in the specified slot.

master   Retrieves crash log or crash data from the switch's chassis processor.

For example, to copy the switch's crash data to a file in a PC:

At this point, press <b>Enter</b> and start the Xmodem command sequence in your terminal emulator.	<pre> HPswitch(config)# copy crash-data xmodem pc Press 'Enter' and start XMODEM on your host...  Transfer complete </pre>
--	--

**Figure A-9. Example of Copying Switch Crash Data Content to a PC**

## File Transfers

Copying Diagnostic Data to a Remote Host, PC, or Unix Workstation

### Copying Crash Log Data Content to a Destination Device

This command uses TFTP or Xmodem to copy the Crash Log content to a PC or UNIX workstation on the network. You can copy individual slot information or the master switch information. If you do not specify either, the command defaults to the master data.

**Syntax:** `copy crash-log [<slot-id | master>] tftp <ip-address>  
<filepath and filename>`

`copy crash-log [<slot-id | master>] xmodem`

where: `slot-id = a - h`, and retrieves the crash log or crash data from the processor on the module in the specified slot.

`master` Retrieves crash log or crash data from the switch's chassis processor.

For example, to copy the Crash Log for slot C to a file in a PC connected to the switch:

At this point, press `[Enter]` and start the Xmodem command sequence in your terminal emulator.

```
HPswitch(config)# copy crash-log c xmodem  
Press 'Enter' and start XMODEM on your host...  
Transfer complete
```

**Figure A-10. Example of sending a Crash Log for Slot C to a File on an Attached PC**

# Monitoring and Analyzing Switch Operation

---

## Contents

<b>Overview</b> .....	B-2
<b>Status and Counters Data</b> .....	B-3
Menu Access To Status and Counters .....	B-4
General System Information .....	B-5
Switch Management Address Information .....	B-6
Module Information .....	B-7
Port Status .....	B-8
Viewing Port and Trunk Group Statistics and Flow Control Status .	B-9
Menu Access to Port and Trunk Statistics .....	B-10
CLI Access To Port and Trunk Group Statistics .....	B-11
Web Browser Access To View Port and Trunk Group Statistics .....	B-11
Viewing the Switch's MAC Address Tables .....	B-12
Menu Access to the MAC Address Views and Searches .....	B-13
CLI Access for MAC Address Views and Searches .....	B-15
Spanning Tree Protocol (STP) Information .....	B-17
Menu Access to STP Data .....	B-17
CLI Access to STP Data .....	B-18
Internet Group Management Protocol (IGMP) Status .....	B-19
VLAN Information .....	B-20
Web Browser Interface Status Information .....	B-22
<b>Port and Static Trunk Monitoring Features</b> .....	B-23
Menu: Configuring Port and Static Trunk Monitoring .....	B-24
CLI: Configuring Port and Static Trunk Monitoring .....	B-26
Web: Configuring Port Monitoring .....	B-28

## Overview

The Switch 4108GL has several built-in tools for monitoring, analyzing, and troubleshooting switch and network operation:

- **Status:** Includes options for displaying general switch information, management address data, port status, port and trunk group statistics, MAC addresses detected on each port or VLAN, and STP, IGMP, and VLAN data (*page B-3*).
- **Counters:** Display details of traffic volume on individual ports (*page B-9*).
- **Event Log:** Lists switch operating events (*“Using the Event Log To Identify Problem Sources” on page C-21*).
- **Alert Log:** Lists network occurrences detected by the switch—in the Status | Overview screen of the web browser interface (*page 4-6*).
- **Configurable trap receivers:** Uses SNMP to enable management stations on your network to receive SNMP traps from the switch (*“Trap Receivers and Authentication Traps” on page 10-8*).
- **Port monitoring (mirroring):** Copy all traffic from the specified ports to a designated monitoring port (*page B-23*).

---

### Note

Link test and ping test—analysis tools in troubleshooting situations—are described in chapter 18, “Troubleshooting”. See page C-24.



## Status and Counters Data

This section describes the status and counters screens available through the switch console interface and/or the web browser interface.

---

**Note**

You can access all console screens from the web browser interface via Telnet to the console. Telnet access to the switch is available in the Device View window under the **Configuration** tab.

---

Status or Counters Type	Interface	Purpose	Page
Menu Access to Status and Counters	Menu	Access menu interface for status and counter data.	<b>B-4</b>
General System Information	Menu, CLI	Lists switch-level operating information.	<b>B-5</b>
Management Address Information	Menu, CLI	Lists the MAC address, IP address, and IPX network number for each VLAN or, if no VLANs are configured, for the switch.	<b>B-6</b>
Module Information	Menu, CLI	Lists the module type and description for each slot in which a module is installed.	<b>B-7</b>
Port Status	Menu, CLI, Web	Displays the operational status of each port.	<b>B-8</b>
Port and Trunk Statistics and Flow Control Status	Menu, CLI, Web	Summarizes port activity and lists per-port flow control status.	<b>B-9</b>
VLAN Address Table	Menu, CLI	Lists the MAC addresses of nodes the switch has detected on specific VLANs, with the corresponding switch port.	<b>B-12</b>
Port Address Table	Menu, CLI	Lists the MAC addresses that the switch has learned from the selected port.	<b>B-12</b>
STP Information	Menu, CLI	Lists Spanning Tree Protocol data for the switch and for individual ports. If VLANs are configured, reports on a per-VLAN basis.	<b>B-17</b>
IGMP Status	Menu, CLI	Lists IGMP groups, reports, queries, and port on which querier is located.	<b>B-19</b>
VLAN Information	Menu, CLI	For each VLAN configured in the switch, lists 802.1Q VLAN ID and up/down status.	<b>B-20</b>
Port Status Overview and Port Counters	Web	Shows port utilization and counters, and the Alert Log.	<b>B-22</b>

---

## Menu Access To Status and Counters

Beginning at the Main Menu, display the Status and Counters menu by selecting:

### 1. Status and Counters

```
=====-- CONSOLE - MANAGER MODE -----  
                        Status and Counters Menu  
  
1. General System Information  
2. Switch Management Address Information  
3. Module Information  
4. Port Status  
5. Port Counters  
6. Vlan Address Table  
7. Port Address Table  
8. Spanning Tree Information  
0. Return to Main Menu...  
  
Displays switch management information including software versions.  
To select menu item, press item number, or highlight item and press <Enter>.
```

**Figure B-1. The Status and Counters Menu**

Each of the above menu items accesses the read-only screens described on the following pages. Refer to the online help for a description of the entries displayed in these screens.

## General System Information

### Menu Access

From the console Main Menu, select:

#### 1. Status and Counters

#### 1. General System Information

```
===== CONSOLE - MANAGER MODE =====
                        Status and Counters - General System Information

System Contact      :
System Location     :

Firmware revision  : E.05.01           Base MAC Addr   : 0001e7-a09900
ROM Version        : E.05.X           Serial Number   : S2600017409

Up Time            : 2 hours           Memory - Total  : 24,588,136
CPU Util (%)       : 1                 Free           : 19,613,568

IP Mgmt - Pkts Rx  : 0                 Packet - Total  : 832
          Pkts Tx  : 0                 Buffers  Free   : 793
                                          Lowest    : 769
                                          Missed    : 0

Actions->  Back      Help

Return to previous screen.
Use arrow keys to change action selection and <Enter> to execute action.
```

**Figure B-2. Example of General Switch Information**

This screen dynamically indicates how individual switch resources are being used. See the online Help for details.

### CLI Access

**Syntax:** show system-information

## Switch Management Address Information

### Menu Access

From the Main Menu, select:

**1 Status and Counters . . .**

**2. Switch Management Address Information**

```
=====-- CONSOLE - MANAGER MODE -----  
                Status and Counters - Management Address Information  
  
Time Server Address : Disabled  
  
VLAN Name      MAC Address      IP Address  
-----  
DEFAULT VLAN  0001e7-a09900    10.28.227.101  
VLAN-22       0001e7-a09901    Disabled  
VLAN-33       0001e7-a09902    Disabled  
  
Actions->     Back      Help  
  
Return to previous screen.  
Use arrow keys to change action selection and <Enter> to execute action.
```

**Figure B-3. Example of Management Address Information with VLANs Configured**

This screen displays addresses that are important for management of the switch. If multiple VLANs are *not* configured, this screen displays a single IP address for the entire switch. See the online Help for details.

### CLI Access

**Syntax:** show management

## Module Information

Use this feature to determine which slots have modules installed and which type(s) of modules are installed.

### Menu: Displaying Port Status

From the Main Menu, select:

1. Status and Counters . . .
3. Module Information

```
HPswitch
-----
                        Status and Counters - Module Information
-----
Slot      Module Type      Module Description
-----
A          HP J4878A 4x MiniGBIC module
B          HP J4820A 10/100Base-TX module
C          Slot Available
D          Slot Available
E          Slot Available
F          Slot Available
G          Slot Available
H          Slot Available

Actions->  Back      Help

Return to previous screen.
Use up/down arrow keys to scroll to other entries, left/right arrow keys to
change action selection, and <Enter> to execute action.
```

Figure B-4. Example of Module Information in the Menu Interface

### CLI Access

**Syntax:** show module

## Port Status

The web browser interface and the console interface show the same port status data.

### Menu: Displaying Port Status

From the Main Menu, select:

1. **Status and Counters . . .**
4. **Port Status**

```
-----  
                          Status and Counters - Port Status  
-----  
Port      Type      Intrusion  Enabled  Status   Mode     Flow  
Alert                                           Ctrl  
-----  
A1                No         Yes      Down    off      off  
A2                No         Yes      Down    off      off  
A3                No         Yes      Down    off      off  
A4                No         Yes      Down    off      off  
B1      10/100TX  No         Yes      Up       100FDx  off  
B2      10/100TX  No         Yes      Down    10FDx   off  
B3      10/100TX  No         Yes      Down    10FDx   off  
B4      10/100TX  No         Yes      Down    10FDx   off  
B5      10/100TX  No         Yes      Down    10FDx   off  
B6      10/100TX  No         Yes      Down    10FDx   off  
B7      10/100TX  No         Yes      Down    10FDx   off  
  
Actions->  Back      Intrusion log  Help  
  
Return to previous screen.  
Use up/down arrow keys to scroll to other entries, left/right arrow keys to  
change action selection, and <Enter> to execute action.
```

Figure B-5. Example of Port Status on the Menu Interface

### CLI Access

**Syntax:** show interfaces brief

### Web Access

1. Click on the **Status** tab.
2. Click on Port Status.

## Viewing Port and Trunk Group Statistics and Flow Control Status

Feature	Default	Menu	CLI	Web
viewing port and trunk statistics for all ports, and flow control status	n/a	page B-10	page B-11	page B-11
viewing a detailed summary for a particular port or trunk	n/a	page B-10	page B-11	page B-11
resetting counters	n/a	page B-10	page B-11	page B-11

These features enable you to determine the traffic patterns for each port since the last reboot or reset of the switch. You can display:

- A general report of traffic on all LAN ports and trunk groups in the switch, along with the per-port flow control status (On or Off).
- A detailed summary of traffic on a selected port or trunk group.

You can also reset the counters for a specific port.

The menu interface and the web browser interface provide a dynamic display of counters summarizing the traffic on each port. The CLI lets you see a static “snapshot” of port or trunk group statistics at a particular moment.

As mentioned above, rebooting or resetting the switch resets the counters to zero. You can also reset the counters to zero for the current session. This is useful for troubleshooting. See the “Note On Reset”, below.

---

### Note on Reset

The **Reset** action resets the counter display to zero for the current session, but does not affect the cumulative values in the actual hardware counters. (In compliance with the SNMP standard, the values in the hardware counters are not reset to zero unless you reboot the switch.) Thus, using the **Reset** action resets the displayed counters to zero for the current session only. Exiting from the console session and starting a new session restores the counter displays to the accumulated values in the hardware counters.

---

## Menu Access to Port and Trunk Statistics

To access this screen from the Main Menu, select:

### 1. Status and Counters . . .

### 4. Port Counters

```
===== CONSOLE - MANAGER MODE =====
                        Status and Counters - Port Counters
-----
```

Port	Total Bytes	Total Frames	Errors Rx	Drops Tx	Flow Ctrl
A1	195,072	323	0	0	off
A2	651,816	871	0	0	off
A3	290,163	500	0	0	off
A4	260,134	501	0	0	off
A5-Trk1	859,363	5147	0	0	off
A6-Trk1	674,574	1693	0	0	off
C1	26,554	246	0	0	off
C2	113,184	276	0	0	off
C3	0	0	0	0	off

```
-----
Actions->  Back   Show details   Reset   Help
Return to previous screen.
Use up/down arrow keys to scroll to other entries, left/right arrow keys to
change action selection, and <Enter> to execute action.
```

Figure B-6. Example of Port Counters on the Menu Interface

To view details about the traffic on a particular port, use the **↓** key to highlight that port number, then select **Show Details**. For example, selecting port A2 displays a screen similar to figure B-7, below.

```
===== CONSOLE - MANAGER MODE =====
                        Status and Counters - Port Counters - Port A2
-----
```

Link Status	: up		
Bytes Rx	: 630,746	Bytes Tx	: 21,070
Unicast Rx	: 568	Unicast Tx	: 285
Bcast/Mcast Rx	: 18	Bcast/Mcast Tx	: 0
FCS Rx	: 0	Drops Tx	: 0
Alignment Rx	: 0	Collisions Tx	: 0
Runts Rx	: 0	Late Colln Tx	: 0
Giants Rx	: 0	Excessive Colln	: 0
Total Rx Errors	: 0	Deferred Tx	: 0

```
-----
Actions->  Back   Reset   Help
Return to previous screen.
Use arrow keys to change action selection and <Enter> to execute action.
```

Figure B-7. Example of the Display for Show details on a Selected Port

This screen also includes the **Reset** action for the current session. (See the “Note on Reset” on page B-9.)



## CLI Access To Port and Trunk Group Statistics

**To Display the Port Counter Summary Report.** This command provides an overview of port activity for all ports on the switch.

**Syntax:** show interfaces

**To Display a Detailed Traffic Summary for Specific Ports.** This command provides traffic details for the port(s) you specify.

**Syntax:** show interfaces [ethernet] <port-list>

**To Reset the Port Counters for a Specific Port.** This command resets the counters for the specified ports to zero for the current session. (See the “Note on Reset” on page B-9.)

**Syntax:** clear statistics <[ethernet] port-list>

## Web Browser Access To View Port and Trunk Group Statistics

1. Click on the **Status** tab.
2. Click on [Port Counters](#).
3. To reset the counters for a specific port, click anywhere in the row for that port, then click on [Refresh](#).

## Viewing the Switch's MAC Address Tables

<b>Feature</b>	<b>Default</b>	<b>Menu</b>	<b>CLI</b>	<b>Web</b>
viewing MAC addresses on all ports on a specific VLAN	n/a	page B-13	page B-15	—
viewing MAC addresses on a specific port	n/a	page B-14	page B-15	—
searching for a MAC address	n/a	page B-14	page B-16	—

These features help you to view:

- The MAC addresses that the switch has learned from network devices attached to the switch
- The port on which each MAC address was learned

## Menu Access to the MAC Address Views and Searches

**Per-VLAN MAC-Address Viewing and Searching.** This feature lets you determine which switch port on a selected VLAN is being used to communicate with a specific device on the network. The per-VLAN listing includes:

- The MAC addresses that the switch has learned from network devices attached to the switch
- The port on which each MAC address was learned

1. From the Main Menu, select:

**1. Status and Counters**  
**5. VLAN Address Table**

2. The switch then prompts you to select a VLAN.

```
Select VLAN : DEFAULT_VLAN
```

3. Use the Space bar to select the VLAN you want, then press [Enter]. The switch then displays the MAC address table for that VLAN:

```
----- CONSOLE - MANAGER MODE -----
                          Status and Counters - Address Table

  MAC Address  Located on Port
  -----
0030c1-7f49c0  A3
0030c1-7fec40  A1
0030c1-b29ac0  A3
0060b0-17de5b  A3
0060b0-880a80  A2
0060b0-df1a00  A3
0060b0-df2a00  A3
0060b0-e9a200  A3
009027-e74f90  A3
080009-21ae84  A3
080009-62c411  A3
080009-6563e2  A3

Actions->  Back  Search  Next page  Prev page  Help

Return to previous screen.
Use up/down arrow keys to scroll to other entries, left/right arrow keys to
change action selection, and <Enter> to execute action.
```

**Figure B-8. Example of the Address Table**

To page through the listing, use **Next page** and **Prev page**.

**Finding the Port Connection for a Specific Device on a VLAN.** This feature uses a device's MAC address that you enter to identify the port used by that device.

1. Proceeding from figure B-8, press **[S]** (for **Search**), to display the following prompt:

Enter MAC address: \_

2. Type the MAC address you want to locate and press **[Enter]**. The address and port number are highlighted if found. If the switch does not find the MAC address on the currently selected VLAN, it leaves the MAC address listing empty.

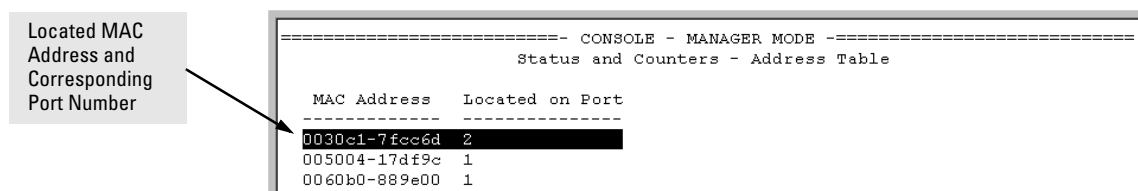

**Figure B-9. Example of Menu Indicating Located MAC Address**

3. Press **[P]** (for **Prev page**) to return to the full address table listing.

**Port-Level MAC Address Viewing and Searching.** This feature displays and searches for MAC addresses on the specified port instead of for all ports on the switch.

1. From the Main Menu, select:

- 1. Status and Counters**  
**7. Port Address Table**

```

===== CONSOLE - MANAGER MODE =====
                        Status and Counters Menu

1. General System Information
2. Switch Management Address Information
3. Module Information
4. Port Status
5. Port Counters
6. Vlan Address Table
7. Port Address Table
8. Spanning Tree Information
0. Return to Main Menu...

Select port : A1
Type port number or press <Space> to scroll ports. Press <Enter> to select.
To select menu item, press item number, or highlight item and press <Enter>.

```

Prompt for Selecting the Port To Search

**Figure B-10. Listing MAC Addresses for a Specific Port**

2. Use the Space bar to select the port you want to list or search for MAC addresses, then press **[Enter]** to list the MAC addresses detected on that port.

**Determining Whether a Specific Device Is Connected to the Selected Port.** Proceeding from step 2, above:

1. Press **[S]** (for **Search**), to display the following prompt:  
Enter MAC address: \_
2. Type the MAC address you want to locate and press **[Enter]**. The address is highlighted if found. If the switch does not find the address, it leaves the MAC address listing empty.
3. Press **[P]** (for **Prev page**) to return to the previous per-port listing.

**CLI Access for MAC Address Views and Searches**

**Syntax:** show mac-address  
          [vlan <vlan-id>  
          [ethernet]<port-list>  
          <mac-addr>

**To List All Learned MAC Addresses on the Switch, with The Port Number on Which Each MAC Address Was Learned.**

HPswitch> show mac-address

**To List All Learned MAC Addresses on one or more ports, with Their**

**Corresponding Port Numbers.** For example, to list the learned MAC address on ports A1 through A4 and port A6:

```
HPswitch> show mac-address a1-a4,a6
```

**To List All Learned MAC Addresses on a VLAN, with Their Port Numbers.** This command lists the MAC addresses associated with the ports for a given VLAN. For example:

```
HPswitch> show mac-address vlan 100
```

---

**Note**

---

The Series 4100GL switches operate with a multiple forwarding database architecture. For more on this topic, refer to “Duplicate MAC Addresses Across VLANs” on page C-19

**To Find the Port On Which the Switch Learned a Specific MAC Address.** For example, to find the port on which the switch learns a MAC address of 080009-21ae84:

```
HPswitch# show mac-address 080009-21ae84
Status and Counters - Address Table - 080009-21ae84
MAC Address : 080009-21ae84
Located on Port : A2
```

**Figure B-11. List the Port on which the Switch Deleted a MAC Address**

## Spanning Tree Protocol (STP) Information

### Menu Access to STP Data

From the Main Menu, select:

1. Status and Counters . . .
8. Spanning Tree Information

STP must be enabled on the switch to display the following data:

```
----- CONSOLE - MANAGER MODE -----
                Status and Counters - Spanning Tree Information

STP Enabled           : Yes
Switch Priority       : 32,768
Hello Time           : 2
Max Age              : 20
Forward Delay        : 15

Topology Change Count : 3
Time Since Last Change : 4 mins

Root MAC Address     : 0030c1-7fcc40
Root Path Cost       : 0
Root Port            : This switch is root
Root Priority         : 32768

Actions->  Back      Show ports  Help
Return to previous screen.
Use arrow keys to change action selection and <Enter> to execute action.
```

**Figure B-12. Example of Spanning Tree Information**

Use this screen to determine current switch-level STP parameter settings and statistics.

You can use the **Show ports** action at the bottom of the screen to display port-level information and parameter settings for each port in the switch (including port type, cost, priority, operating state, and designated bridge) as shown in figure B-13.

```
----- CONSOLE - MANAGER MODE -----  
Status and Counters - Spanning Tree - Port Information  
  
Port      Type      Cost    Priority  State      Designated Bridge  
-----  
A1      100/1000T  5       128      Forwarding 0001e7-a09900  
A2      100/1000T  5       128      Forwarding 0001e7-a09900  
A3      100/1000T  5       128      Disabled  
A4      100/1000T  5       128      Disabled  
A5      100/1000T  5       128      Disabled  
A6      100/1000T  5       128      Disabled  
C1      1000SX     5       128      Forwarding 0001e7-a09900  
C2      1000SX     5       128      Forwarding 0001e7-a09900  
C3      1000SX     5       128      Forwarding 0001e7-a09900  
  
Actions->  Back      Help  
  
Return to previous screen.  
Use up/down arrow keys to scroll to other entries, left/right arrow keys to  
change action selection, and <Enter> to execute action.
```

Figure B-13. Example of STP Port Information

### CLI Access to STP Data

This option lists the STP configuration, root data, and per-port data (cost, priority, state, and designated bridge).

**Syntax:** show spanning-tree

```
HP4100> show spanning-tree
```



## Internet Group Management Protocol (IGMP) Status

The switch uses the CLI to display the following IGMP status on a per-VLAN basis:

Show Command	Output
show ip igmp	Global command listing IGMP status for all VLANs configured in the switch: <ul style="list-style-type: none"> <li>• VLAN ID (VID) and name</li> <li>• Active group addresses per VLAN</li> <li>• Number of report and query packets per group</li> <li>• Querier access port per VLAN</li> </ul>
show ip igmp <vlan-id>	Per-VLAN command listing above IGMP status for specified VLAN (VID)
show ip igmp group <ip-addr>	Lists the ports currently participating in the specified group, with port type, Access type, Age Timer data and Leave Timer data.

For example, suppose that **show ip igmp** listed an IGMP group address of 224.0.1.22. You could get additional data on that group by executing the following:

```

HP4108> show ip igmp group 224.0.1.22

IGMP ports for group 224.0.1.22

Port Type      Access      Age Timer  Leave Timer
-----
3    10/100TX    host        0          0
  
```

**Figure B-14. Example of IGMP Group Data**

## VLAN Information

The switch uses the CLI to display the following VLAN status:

Show Command	Output
show vlan	Lists: <ul style="list-style-type: none"><li>• Maximum number of VLANs to support</li><li>• Existing VLANs</li><li>• Status (static or dynamic)</li><li>• Primary VLAN</li></ul>
show vlan <vlan-id>	For the specified VLAN, lists: <ul style="list-style-type: none"><li>• Name, VID, and status (static/dynamic)</li><li>• Per-Port mode (tagged, untagged, forbid, no/auto)</li><li>• "Unknown VLAN" setting (Learn, Block, Disable)</li><li>• Port status (up/down)</li></ul>

For example, suppose that your switch has the following VLANs:

Ports	VLAN	VID
1 - 12	DEFAULT_VLAN	1
1, 2	VLAN-33	33
3, 4	VLAN-44	44

The next three figures show how you could list data on the above VLANs.

### Listing the VLAN ID (VID) and Status for ALL VLANs in the Switch.

```
HPswitch> show vlan
Status and Counters - VLAN Information
VLAN support : Yes
Maximum VLANs to support : 9
Primary VLAN: DEFAULT_VLAN

802.1Q VLAN ID Name          Status  --
-----
1          DEFAULT_VLAN  Static
33         VLAN-33     Static
44         VLAN-44     Static
```

Figure B-15. Example of VLAN Listing for the Entire Switch

**Listing the VLAN ID (VID) and Status for Specific Ports.**

Because ports A1 and A2 are not members of VLAN-44, it does not appear in this listing.

```

HPswitch>show vlan ports A1-A2
Status and Counters - VLAN Information - for ports A1,A2
802.1Q VLAN ID Name          Status
-----
1          DEFAULT_VLAN  Static
33         VLAN-33       Static
  
```

**Figure B-16. Example of VLAN Listing for Specific Ports**

**Listing Individual VLAN Status.**

```

HPswitch>show vlan 1
Status and Counters - VLAN Information - Ports - VLAN 1
802.1Q VLAN ID : 1
Name           : DEFAULT_VLAN
Status        : Static

Port Information Mode      Unknown VLAN Status
-----
A1             Untagged Learn      Up
A2             Tagged   Learn      Up
A3             Untagged Learn      Up
A4             Untagged Learn      Down
A5             Untagged Learn      Down
.              .              .              .
.              .              .              .
.              .              .              .
  
```

**Figure B-17. Example of Port Listing for an Individual VLAN**

## Web Browser Interface Status Information

The “home” screen for the web browser interface is the Status Overview screen, as shown below. As the title implies, it provides an overview of the status of the switch, including summary graphs indicating the network utilization on each of the switch ports, symbolic port status indicators, and the Alert Log, which informs you of any problems that may have occurred on the switch.

For more information on this screen, see chapter 4, ‘Using the HP Web Browser Interface’.

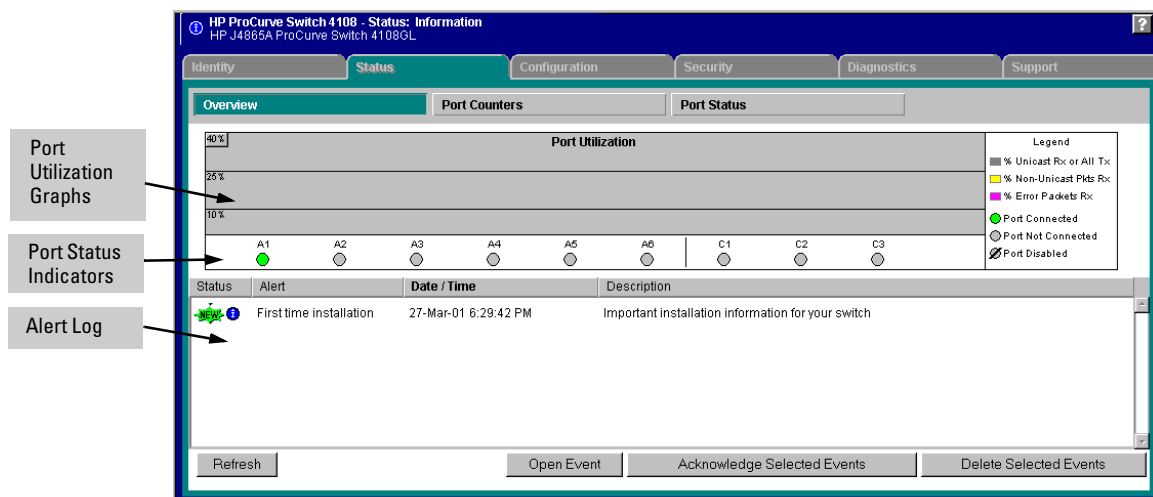

Figure B-18. Example of a Web Browser Interface Status Overview Screen

## Port and Static Trunk Monitoring Features

### Port Monitoring Features

Feature	Default	Menu	CLI	Web
display monitoring configuration	disabled	page B-24	page B-26	page B-28
configure the monitor port(s)	ports: none	page B-24	page B-26	page B-28
selecting or removing ports	none selected	page B-24	page B-27	page B-28

You can designate a port for monitoring incoming traffic of other ports and of static trunks on the switch. The switch monitors the network activity by copying all traffic inbound on the specified interfaces to the designated monitoring port, to which a network analyzer can be attached.

---

### Note

Port trunks cannot be used as a monitoring port.

It is possible, when monitoring multiple interfaces in networks with high traffic levels, to copy more traffic to a monitor port than the link can support. In this case, some packets may not be copied to the monitor port.

---

## Menu: Configuring Port and Static Trunk Monitoring

This procedure describes configuring the switch for monitoring when monitoring is disabled. (If monitoring has already been enabled, the screens will appear differently than shown in this procedure.)

1. From the Console Main Menu, Select:
  2. **Switch Configuration...**
  3. **Network Monitoring Port**

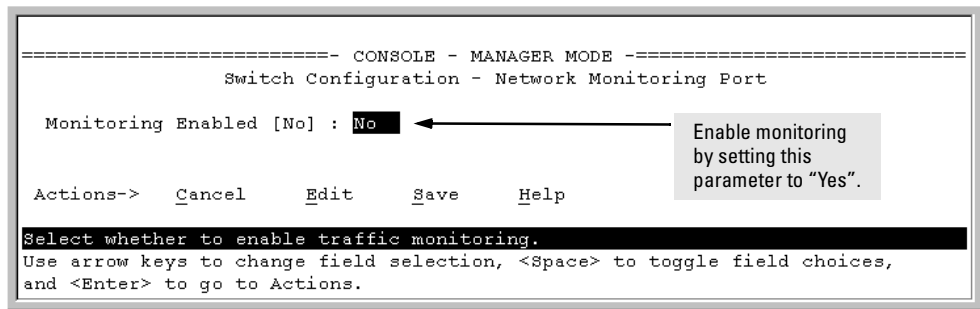

**Figure B-19. The Default Network Monitoring Configuration Screen**

2. In the Actions menu, press **[E]** (for **Edit**).
3. If monitoring is currently disabled (the default) then enable it by pressing the Space bar (or **[Y]**) to select **Yes**.
4. Press the downarrow key to display a screen similar to the following and move the cursor to the **Monitoring Port** parameter.

```

----- CONSOLE - MANAGER MODE -----
Switch Configuration - Network Monitoring Port

Monitoring Enabled [No] : Yes
Monitoring Port : A1
Monitor : Ports

Port      Type      Action      |      Port      Type      Action
-----
A1      10/100TX      +           |      A10     10/100TX      +
A2      10/100TX      |      A11     10/100TX      |
A3      10/100TX      |      A12     10/100TX      |
A4      10/100TX      |      A13     10/100TX      |
A5      10/100TX      |      A14     10/100TX      |
A6      10/100TX      |      A15     10/100TX      |
A7      10/100TX      |      A20     10/100TX      |
A8      10/100TX      |      Trk1    Trunk          |

Actions->  C_a_ncel      E_dit      S_a_ve      H_e_l_p

Select the port that will act as the Monitoring Port.
Use arrow keys to change field selection, <Space> to toggle field choices,
and <Enter> to go to Actions.

```

**Figure B-20. How To Select a Monitoring Port**

5. Use the Space bar to select the port to use for monitoring.
6. Use the downarrow key to move the cursor to the **Action** column for the individual ports and position the cursor at a port you want to monitor.
7. Press the Space bar to select **Monitor** for each port and trunk that you want monitored. (Use the downarrow key to move from one interface to the next in the **Action** column.)
8. When you finish selecting ports to monitor, press **[Enter]**, then press **[S]** (for **Save**) to save your changes and exit from the screen.
9. Return to the Main Menu.

## CLI: Configuring Port and Static Trunk Monitoring

### Port and Static Trunk Monitoring Commands Used in This Section

show monitor	below
mirror-port	page B-26
monitor	page B-27

You must use the following configuration sequence to configure port and static trunk monitoring in the CLI:

1. Assign a monitoring (mirror) port.
2. Designate the port(s) and static trunk(s) to monitor.

**Displaying the Monitoring Configuration.** This command lists the port assigned to receive monitored traffic and the ports and/or trunks being monitored.

**Syntax:** show monitor

For example, if you assign port A6 as the monitoring port and configure the switch to monitor ports A1 - A3, **show monitor** displays the following:

```
HPswitch(config)# show monitor

Network Monitoring Port

Mirror Port: A6
Monitoring sources
-----
A1
A2
A3
```

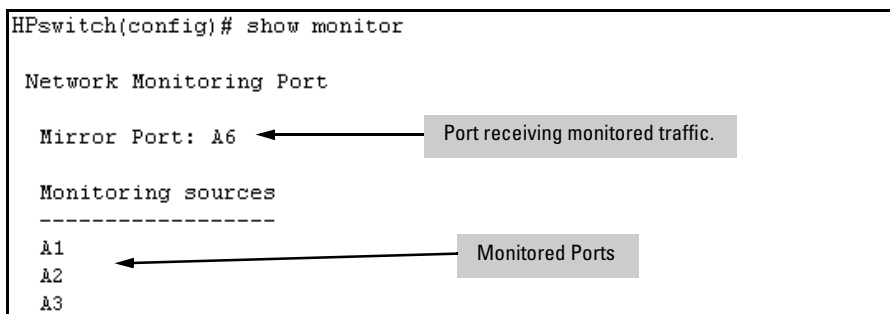

**Figure B-21. Example of Monitored Port Listing**

**Configuring the Monitor Port.** This command assigns or removes a monitoring port, and must be executed from the global configuration level. Removing the monitor port disables port monitoring and resets the monitoring parameters to their factory-default settings.

**Syntax:** [no] mirror-port [< port-num >]

For example, to assign port A6 as the monitoring port:

```
HPswitch(config)# mirror-port a6
```



To turn off monitoring:

```
HPswitch(config)# no mirror-port
```

### Selecting or Removing Ports and Static Trunks As Monitoring

**Sources.** After you configure a monitor port you can use either the global configuration level or the interface context level to select ports and static trunks as monitoring sources. You can also use either level to remove monitoring sources.

**Syntax:** [no] interface ethernet < monitor-list >

*where:* < monitor-list > includes port numbers and static trunk names such as a4, c7, b5-b8, and trk1.

Elements in the monitor list can include port numbers and static trunk names at the same time.

For example, with a port such as port A6 configured as the monitoring (mirror) port, you would use either of the following commands to select these ports and static trunks for monitoring:

- A1 through A3, and A5
- Trunks 1 and 2

```
HPswitch(config)# int e a1-a3,a5, trk1, trk2 monitor
HPswitch(config)# int e a1-a3,a5, trk1, trk2
HPswitch(eth-A1-A3,A5,Trk1-Trk2)# monitor
```

From the global config level, selects ports and trunks for monitoring sources.

Selects the interface context level, then selects the ports as monitoring sources.

Figure B-22. Examples of Selecting Ports and Static Trunks as Monitoring Sources

```
HPswitch(eth-A1-A3,A5)# no int e a5 monitor
HPswitch(eth-A1-A3,A5)# no monitor
HPswitch(config)# no int e a5 monitor
HPswitch(config)# no int e a1-a3,a5 monitor
```

These two commands show how to disable monitoring at the interface context level for a single port or all ports in an interface context level.

These two commands show how to disable monitoring at the global config level for a single port or a group of ports.

Figure B-23. Examples of Removing Ports as Monitoring Sources

## Web: Configuring Port Monitoring

To enable port monitoring:

1. Click on the **Configuration** tab.
2. Click on .
3. To monitor one or more ports.
  - a. Click on the radio button for **Monitor Selected Ports**.
  - b. Select the port(s) to monitor.
4. Click on .

To remove port monitoring:

1. Click on the **Monitoring Off** radio button.
2. Click on .

For web-based Help on how to use the web browser interface screen, click on the  button provided on the web browser screen.

# Troubleshooting

---

## Contents

<b>Overview</b> .....	C-2
<b>Troubleshooting Approaches</b> .....	C-3
<b>Browser or Telnet Access Problems</b> .....	C-4
<b>Unusual Network Activity</b> .....	C-6
General Problems .....	C-6
Prioritization Problems .....	C-7
CDP Problems .....	C-7
IGMP-Related Problems .....	C-8
LACP-Related Problems .....	C-9
Port-Based Access Control (802.1x)-Related Problems .....	C-9
Radius-Related Problems .....	C-12
Spanning-Tree Protocol (STP) and Fast-Uplink Problems .....	C-14
SSH-Related Problems .....	C-15
Stacking-Related Problems .....	C-16
TACACS-Related Problems .....	C-16
TimeP, SNMP, or Gateway Problems .....	C-18
VLAN-Related Problems .....	C-18
<b>Using the Event Log To Identify Problem Sources</b> .....	C-21
<b>Diagnostic Tools</b> .....	C-24
Port Auto-Negotiation .....	C-24
Ping and Link Tests .....	C-24
Displaying the Configuration File .....	C-29
<b>Listing Switch Configuration and Operation Details for Help in Troubleshooting</b> .....	C-30
Web: Viewing the Configuration File .....	C-32
CLI Administrative and Troubleshooting Commands .....	C-33
<b>Restoring the Factory-Default Configuration</b> .....	C-34
<b>Restoring a Flash Image</b> .....	C-35

## Overview

This chapter addresses performance-related network problems that can be caused by topology, switch configuration, and the effects of other devices or their configurations on switch operation. (For switch-specific information on hardware problems indicated by LED behavior, cabling requirements, and other potential hardware-related problems, refer to the installation guide you received with the switch.)

---

### **Note**

HP periodically places switch software updates on the HP Procurve website. HP recommends that you check this website for software updates that may have fixed a problem you are experiencing.

For information on support and warranty provisions, see the Support and Warranty booklet shipped with the switch.

# Troubleshooting Approaches

Use these approaches to diagnose switch problems:

- Check the HP Procurve website for software updates that may have solved your problem: <http://www.hp.com/go/hpprocurve>
- Check the switch LEDs for indications of proper switch operation:
  - Each switch port has a Link LED that should light whenever an active network device is connected to the port.
  - Problems with the switch hardware and software are indicated by flashing the Fault and other switch LEDs.

See the *Installation Guide* shipped with the switch for a description of the LED behavior and information on using the LEDs for troubleshooting.

- Check the network topology/installation. See the *Installation Guide* shipped with the switch for topology information.
- Check cables for damage, correct type, and proper connections. You should also use a cable tester to check your cables for compliance to the relevant IEEE 802.3 specification. See the *Installation Guide* shipped with the switch for correct cable types and connector pin-outs.
- Use HP TopTools for Hubs & Switches (if installed on your network) to help isolate problems and recommend solutions. HP TopTools is shipped at no extra cost with the switch.
- Use the Port Utilization Graph and Alert Log in the web browser interface included in the switch to help isolate problems. See Chapter 4, “Using the HP Web Browser Interface” for operating information. These tools are available through the web browser interface:
  - Port Utilization Graph
  - Alert Log
  - Port Status and Port Counters screens
  - Diagnostic tools (Link test, Ping test, configuration file browser)
- For help in isolating problems, use the easy-to-access switch console built into the switch or Telnet to the switch console. See chapter 4, “Using the Switch Console Interface” for operating information. These tools are available through the switch console
  - Status and Counters screens
  - Event Log
  - Diagnostics tools (Link test, Ping test, configuration file browser, and advanced user commands)

## Browser or Telnet Access Problems

### Cannot access the web browser interface:

- Access may be disabled by the **Web Agent Enabled** parameter in the switch console. Check the setting on this parameter by selecting:

#### 2. Switch Configuration . . .

##### 1. System Information

- The switch may not have the correct IP address, subnet mask or gateway. Verify by connecting a console to the switch's Console port and selecting:

#### 2. Switch Configuration . . .

##### 5. IP Configuration

**Note:** If DHCP/Bootp is used to configure the switch, the IP addressing can be verified by selecting:

#### 1. Status and Counters . . .

#### 2. Switch Management Address Information

also check the DHCP/Bootp server configuration to verify correct IP addressing.

- If you are using DHCP to acquire the IP address for the switch, the IP address "lease time" may have expired so that the IP address has changed. For more information on how to "reserve" an IP address, refer to the documentation for the DHCP application that you are using.
- If one or more IP-Authorized managers are configured, the switch allows web browser access only to a device having an authorized IP address. For more information on IP Authorized managers, see the *Access Security Guide* for your switch.
- Java™ applets may not be running on the web browser. They are required for the switch web browser interface to operate correctly. See the online Help on your web browser for how to run the Java applets.

**Cannot Telnet into the switch console from a station on the network:**

- Telnet access may be disabled by the **Inbound Telnet Enabled** parameter in the System Information screen of the menu interface:

**2. Switch Configuration**

**1. System Information**

- The switch may not have the correct IP address, subnet mask, or gateway. Verify by connecting a console to the switch's Console port and selecting:

**2. Switch Configuration**

**5. IP Configuration**

**Note:** If DHCP/Bootp is used to configure the switch, see the **Note**, above.

- If you are using DHCP to acquire the IP address for the switch, the IP address "lease time" may have expired so that the IP address has changed. For more information on how to "reserve" an IP address, refer to the documentation for the DHCP application that you are using.
- If one or more IP-Authorized managers are configured, the switch allows inbound telnet access only to a device having an authorized IP address. For more information on IP Authorized managers, see see the *Access Security Guide* for your switch.

## Unusual Network Activity

Network activity that fails to meet accepted norms may indicate a hardware problem with one or more of the network components, possibly including the switch. Such problems can also be caused by a network loop or simply too much traffic for the network as it is currently designed and implemented. Unusual network activity is usually indicated by the LEDs on the front of the switch or measured with the switch console interface or with a network management tool such as the HP TopTools for Hubs & Switches. Refer to the *Installation Guide* you received with the switch for information on using LEDs to identify unusual network activity.

A topology loop can also cause excessive network activity. The event log "FFI" messages can be indicative of this type of problem.

### General Problems

**The network runs slow; processes fail; users cannot access servers or other devices.** Broadcast storms may be occurring in the network. These may be due to redundant links between nodes.

- If you are configuring a port trunk, finish configuring the ports in the trunk before connecting the related cables. Otherwise you may inadvertently create a number of redundant links (i.e. topology loops) that will cause broadcast storms.
- Turn on Spanning Tree Protocol to block redundant links (i.e. topology loops)
- Check for FFI messages in the Event Log.

**Duplicate IP Addresses.** This is indicated by this Event Log message:

**ip: Invalid ARP source: *IP address* on *IP address***

*where:* both instances of *IP address* are the same address, indicating the switch's IP address has been duplicated somewhere on the network.

**Duplicate IP Addresses in a DHCP Network.** If you use a DHCP server to assign IP addresses in your network and you find a device with a valid IP address that does not appear to communicate properly with the server or other devices, a duplicate IP address may have been issued by the server. This can occur if a client has not released a DHCP-assigned IP address after the intended expiration time and the server "leases" the address to another device.



This can also happen, for example, if the server is first configured to issue IP addresses with an unlimited duration, then is subsequently configured to issue IP addresses that will expire after a limited duration. One solution is to configure “reservations” in the DHCP server for specific IP addresses to be assigned to devices having specific MAC addresses. For more information, refer to the documentation for the DHCP server.

One indication of a duplicate IP address in a DHCP network is this Event Log message:

**ip: Invalid ARP source: IP address on IP address**

*where:* both instances of *IP address* are the same address, indicating the IP address that has been duplicated somewhere on the network.

**The Switch Has Been Configured for DHCP/Bootp Operation, But Has Not Received a DHCP or Bootp Reply.** When the switch is first configured for DHCP/Bootp operation, or if it is rebooted with this configuration, it immediately begins sending request packets on the network. If the switch does not receive a reply to its DHCP/Bootp requests, it continues to periodically send request packets, but with decreasing frequency. Thus, if a DHCP or Bootp server is not available or accessible to the switch when DHCP/Bootp is first configured, the switch may not immediately receive the desired configuration. After verifying that the server has become accessible to the switch, reboot the switch to re-start the process.

## Prioritization Problems

**Ports configured for non-default prioritization (level 1 - 7) are not performing the specified action.** If the ports were placed in a trunk group after being configured for non-default prioritization, the priority setting was automatically reset to zero (the default). Ports in a trunk group operate only at the default priority setting.

## CDP Problems

**The switch does not appear in the CDP Neighbors table of an adjacent CDP Device.** This may be due to any of the following:

- Either the port connecting the switch to the adjacent device is not a member of an untagged VLAN or any Untagged VLAN to which the port belongs does not have an IP address.
- If there is more than one physical path between the switch and the other CDP device and STP is running on the switch, then STP will block the redundant link(s). In this case, the switch port on the

remaining open link may not be a member of an untagged VLAN, or any untagged VLANs to which the port belongs may not have an IP address.

- The adjacent device's CDP Neighbors table may be full. Refer to the documentation provided for the adjacent CDP device to determine the table's capacity, and then view the device's Neighbors table to determine whether it is full.

**One or more CDP neighbors appear intermittently or not at all in the switch's CDP Neighbors table.** This may be caused by more than 60 neighboring devices sending CDP packets to the switch. Exceeding the 60-neighbor limit can occur, for example, where multiple neighbors are connected to the switch through non-CDP devices such as many hubs.

**The Same CDP Switch or Router Appears on More Than One Port in the CDP Neighbors Table.** Where CDP is running, a switch or router that is the STP root transmits outbound CDP packets over all links, including redundant links that STP may be blocking in non-root devices. In this case, the non-root device shows an entry in its CDP Neighbors table for every port on which it receives a CDP packet from the root device. See "Effect of Spanning Tree (STP) On CDP Packet Transmission" on page 10-24.

## IGMP-Related Problems

**IP Multicast (IGMP) Traffic That Is Directed By IGMP Does Not Reach IGMP Hosts or a Multicast Router Connected to a Port.** IGMP must be enabled on the switch and the affected port must be configured for "Auto" or "Forward" operation.

**IP Multicast Traffic Floods Out All Ports; IGMP Does Not Appear To Filter Traffic.** The IGMP feature does not operate if the switch or VLAN does not have an IP address configured manually or obtained through DHCP/Bootp. To verify whether an IP address is configured for the switch or VLAN, do either of the following:

- **Try Using the Web Browser Interface:** If you can access the web browser interface, then an IP address is configured.
- **Try To Telnet to the Switch Console:** If you can Telnet to the switch, then an IP address is configured.
- **Using the Switch Console Interface:** From the Main Menu, check the Management Address Information screen by clicking on

- 1. Status and Counters**

- 2. Switch Management Address Information**

## LACP-Related Problems

Unable to enable LACP on a port with the **interface [ e ] < port-number > lacp** command. In this case, the switch displays the following message:

```
Operation is not allowed for a trunked port.
```

You cannot enable LACP on a port while it is configured as static **Trunk** or **FEC** trunked port. To enable LACP on static-trunked port, first use the **no trunk [ e ] < port-number >** command to disable the static trunk assignment, then execute **interface [ e ] < port-number > lacp**.

---

### Caution

Removing a port from a trunk without first disabling the port can create a traffic loop that can slow down or halt your network. Before removing a port from a trunk, HP recommends that you either disable the port or disconnect it from the LAN.

## Port-Based Access Control (802.1x)-Related Problems

---

### Note

To list the 802.1x port-access Event Log messages stored on the switch, use **show log 802**.

See also “Radius-Related Problems” on page C-12.

**The switch does not receive a response to RADIUS authentication requests.** In this case, the switch will attempt authentication using the secondary method configured for the type of access you are using (console, Telnet, or SSH).

There can be several reasons for not receiving a response to an authentication request. Do the following:

- Use **ping** to ensure that the switch has access to the configured RADIUS servers.
- Verify that the switch is using the correct encryption key (RADIUS secret key) for each server.
- Verify that the switch has the correct IP address for each RADIUS server.
- Ensure that the **radius-server timeout** period is long enough for network conditions.

**The switch does not authenticate a client even though the RADIUS server is properly configured and providing a response to the**

**authentication request.** If the RADIUS server configuration for authenticating the client includes a VLAN assignment, ensure that the VLAN exists as a static VLAN on the switch. See "How 802.1x Authentication Affects VLAN Operation" in the *Access Security Guide* for your switch.

**During RADIUS-authenticated client sessions, access to a VLAN on the port used for the client sessions is lost.** If the affected VLAN is configured as untagged on the port, it may be temporarily blocked on that port during an 802.1x session. This is because the switch has temporarily assigned another VLAN as untagged on the port to support the client access, as specified in the response from the RADIUS server. See "How 802.1x Authentication Affects VLAN Operation" in the *Access Security Guide* for your switch.

**The switch appears to be properly configured as a supplicant, but cannot gain access to the intended authenticator port on the switch to which it is connected.** If **aaa authentication port-access** is configured for Local, ensure that you have entered the local *login* (operator-level) username and password of the authenticator switch into the **identity** and **secret** parameters of the supplicant configuration. If instead, you enter the enable (manager-level) username and password, access will be denied.

**The supplicant statistics listing shows multiple ports with the same authenticator MAC address.** The link to the authenticator may have been moved from one port to another without the supplicant statistics having been cleared from the first port. Refer to the "Note on Supplicant Statistics" in the *Access Security Guide* for your switch.

**The show port-access authenticator <port-list> command shows one or more ports remain open after they have been configured with control unauthorized.** 802.1x is not active on the switch. After you execute **aaa port-access authenticator active**, all ports configured with **control unauthorized** should be listed as **Closed**.

```

HPswitch(config)# show port-access authenticator e A9
Port Access Authenticator Status
Port-access authenticator activated [No] : No
Access Authenticator Authenticator
Port Status Control State Backend State
-----
A9 Open FU Force Auth Idle

HPswitch(config)# aaa port-access authenticator active

HPswitch(config)# show port-access authenticator e A9
Port Access Authenticator Status
Port-access authenticator activated [No] : Yes
Access Authenticator Authenticator
Port Status Control State Backend State
-----
A9 Closed FU Force Unauth Idle

```

Port A9 shows an "Open" status even though Access Control is set to **Unauthorized** (Force Auth). This is because the port-access authenticator has not yet been activated.

**Figure C-1. Example of a Port Remaining Open After Being Configured with "Control Unauthorized"**

**RADIUS server fails to respond to a request for service, even though the server's IP address is correctly configured in the switch.** Use **show radius** to verify that the encryption key (RADIUS secret key) the switch is using is correct for the server being contacted. If the switch has only a global key configured, then it either must match the server key or you must configure a server-specific key. If the switch already has a server-specific key assigned to the server's IP address, then it overrides the global key and must match the server key.

```

10.33.18.119(config)# show radius
Status and Counters - General RADIUS Information
  Deadtime(min) : 0
  Timeout(secs) : 5
  Retransmit Attempts : 3
  Global Encryption Key : My-Global-Key

Server IP Addr  Auth Port  Acct Port  Encryption Key
-----
10.33.18.119   1812  1813  119-only-key

```

Global RADIUS Encryption Key

Unique RADIUS Encryption Key for the RADIUS server at 10.33.18.119

Also, ensure that the switch port used to access the RADIUS server is not blocked by an 802.1x configuration on that port. For example, **show port-access authenticator < port-list >** gives you the status for the specified ports. Also, ensure that other factors, such as port security or any 802.1x configuration on the RADIUS server are not blocking the link.

**The authorized MAC address on a port that is configured for both 802.1x and port security either changes or is re-acquired after execution of `aaa port-access authenticator <port-list> initialize`.** If the port is force-authorized with `aaa port-access authenticator <port-list> control authorized` command and port security is enabled on the port, then executing `initialize` causes the port to clear the learned address and learn a new address from the first packet it receives after you execute `initialize`.

**A trunked port configured for 802.1x is blocked.** If you are using RADIUS authentication and the RADIUS server specifies a VLAN for the port, the switch allows authentication, but blocks the port. To eliminate this problem, either remove the port from the trunk or reconfigure the RADIUS server to avoid specifying a VLAN.

## Radius-Related Problems

**The switch does not receive a response to RADIUS authentication requests.** In this case, the switch will attempt authentication using the secondary method configured for the type of access you are using (console, Telnet, or SSH).

There can be several reasons for not receiving a response to an authentication request. Do the following:

- Use **ping** to ensure that the switch has access to the configured RADIUS server.
- Verify that the switch is using the correct encryption key for the designated server.
- Verify that the switch has the correct IP address for the RADIUS server.
- Ensure that the **radius-server timeout** period is long enough for network conditions.
- Verify that the switch is using the same UDP port number as the server.

**RADIUS server fails to respond to a request for service, even though the server's IP address is correctly configured in the switch.** Use **show radius** to verify that the encryption key the switch is using is correct for the server being contacted. If the switch has only a global key configured, then it either must match the server key or you must configure a server-specific key. If the switch already has a server-specific key assigned to the server's IP address, then it overrides the global key and must match the server key.

```
10.33.18.119(config)# show radius
Status and Counters - General RADIUS Information
  Deadttime(min) : 0
  Timeout(secs) : 5
  Retransmit Attempts : 3
  Global Encryption Key : My-Global-Key

Server IP Addr      Auth  Acct
                  Port  Port  Encryption Key
-----
10.33.18.119      1812 1813  119-only-key
```

Global RADIUS Encryption Key

Unique RADIUS Encryption Key  
for the RADIUS server at  
10.33.18.119

Figure C-2. Examples of Global and Unique Encryption Keys

## Spanning-Tree Protocol (STP) and Fast-Uplink Problems

---

### Caution

---

If you enable STP, it is recommended that you leave the remainder of the STP parameter settings at their default values until you have had an opportunity to evaluate STP performance in your network. Because incorrect STP settings can adversely affect network performance, you should avoid making changes without having a strong understanding of how STP operates. To learn the details of STP operation, refer to the IEEE 802.1d standard.

**Broadcast Storms Appearing in the Network.** This can occur when there are physical loops (redundant links) in the topology. Where this exists, you should enable STP on all bridging devices in the topology in order for the loop to be detected.

**STP Blocks a Link in a VLAN Even Though There Are No Redundant Links in that VLAN.** In 802.1Q-compliant switches such as the Switch 4108GL, STP blocks redundant physical links even if they are in separate VLANs. A solution is to use only one, multiple-VLAN (tagged) link between the devices. Also, if ports are available, you can improve the bandwidth in this situation by using a port trunk. See “Spanning Tree Operation with VLANs” on page 11-30.

**Fast-Uplink Troubleshooting.** Some of the problems that can result from incorrect useage of Fast-Uplink STP include temporary loops and generation of duplicate packets.

Problem sources can include:

- Fast-Uplink is configured on a switch that is the STP root device.
- Either the **Hello Time** or the **Max Age** setting (or both) is too long on one or more switches. Return the **Hello Time** and Max Age settings to their default values (2 seconds and 20 seconds, respectively, on a switch).
- A "downlink" port is connected to a switch that is further away (in hop count) from the root device than the switch port on which fast-uplink STP is configured.
- Two edge switches are directly linked to each other with a fast-uplink (Mode = **Uplink**) connection.
- Fast uplink is configured on both ends of a link.
- A switch serving as a backup STP root switch has ports configured for fast-uplink STP and has become the root device due to a failure in the original root device.



## SSH-Related Problems

**Switch access refused to a client.** Even though you have placed the client's public key in a text file and copied the file (using the **copy tftp pub-key-file** command) into the switch, the switch refuses to allow the client to have access. If the source SSH client is an SSHv2 application, the public key may be in the PEM format, which the switch (SSHv1) does not interpret. Check the SSH client application for a utility that can convert the PEM-formatted key into an ASCII-formatted key.

**Executing ip ssh does not enable SSH on the switch.** The switch does not have a host key. Verify by executing `show ip host-public-key`. If you see the message

```
ssh cannot be enabled until a host key is configured
(use 'crypto' command).
```

then you need to generate an SSH key pair for the switch. To do so, execute **crypto key generate**. (Refer to "2. Generating the Switch's Public and Private Key Pair" in the *Access Security Guide* for your switch.)

**Switch does not detect a client's public key that does appear in the switch's public key file (show ip client-public-key).** The client's public key entry in the public key file may be preceded by another entry that does not terminate with a new line (CR). In this case, the switch interprets the next sequential key entry as simply a comment attached to the preceding key entry. Where a public key file has more than one entry, ensure that all entries terminate with a newline (CR). While this is optional for the last entry in the file, not adding a newline to the last entry creates an error potential if you either add another key to the file at a later time or change the order of the keys in the file.

**An attempt to copy a client public-key file into the switch has failed and the switch lists one of the following messages.**

```
Download failed: overlength key in key file.
```

```
Download failed: too many keys in key file.
```

```
Download failed: one or more keys is not a valid RSA
public key.
```

The public key file you are trying to download has one of the following problems:

- A key in the file is too long. The maximum key length is 1024 characters, including spaces. This could also mean that two or more keys are merged together instead of being separated by a <CR><LF>.
- There are more than ten public keys in the key file.
- One or more keys in the file is corrupted or is not a valid rsa public key.

**Client ceases to respond ("hangs") during connection phase.** The switch does not support data compression in an SSH session. Clients will often have compression turned on by default, but will disable it during the negotiation phase. A client which does not recognize the compression-request FAILURE response may fail when attempting to connect. Ensure that compression is turned off before attempting a connection to prevent this problem.

## Stacking-Related Problems

**The Stack Commander Cannot Locate any Candidates.** Stacking operates on the primary VLAN, which in the default configuration is the DEFAULT\_VLAN. However, if another VLAN has been configured as the primary VLAN, and the Commander is not on the primary VLAN, then the Commander will not detect Candidates on the primary VLAN.

## TACACS-Related Problems

**Event Log.** When troubleshooting TACACS+ operation, check the switch's Event Log for indications of problem areas.

**All Users Are Locked Out of Access to the Switch.** If the switch is functioning properly, but no username/password pairs result in console or Telnet access to the switch, the problem may be due to how the TACACS+ server and/or the switch are configured. Use one of the following methods to recover:

- Access the TACACS+ server application and adjust or remove the configuration parameters controlling access to the switch.
- If the above method does not work, try eliminating configuration changes in the switch that have not been saved to flash (boot-up configuration) by causing the switch to reboot from the boot-up configuration (which includes only the configuration changes made prior to the last **write memory** command.) If you did not use **write memory** to save the authentication configuration to flash, then pressing the Reset button or cycling the power reboots the switch with the boot-up configuration.

- Disconnect the switch from network access to any TACACS+ servers and then log in to the switch using either Telnet or direct console port access. Because the switch cannot access a TACACS+ server, it will default to local authentication. You can then use the switch's local Operator or Manager username/password pair to log on.
- As a last resort, use the Clear/Reset button combination to reset the switch to its factory default boot-up configuration. Taking this step means you will have to reconfigure the switch to return it to operation in your network.

**No Communication Between the Switch and the TACACS+ Server Application.** If the switch can access the server device (that is, it can **ping** the server), then a configuration error may be the problem. Some possibilities include:

- The server IP address configured with the switch's `tacacs-server host` command may not be correct. (Use the switch's `show tacacs-server` command to list the TACACS+ server IP address.)
- The encryption key configured in the server does not match the encryption key configured in the switch (by using the `tacacs-server key` command). Verify the key in the server and compare it to the key configured in the switch. (Use `show tacacs-server` to list the global key. Use `show config` or `show config running` to list any server-specific keys.)
- The accessible TACACS+ servers are not configured to provide service to the switch.

**Access Is Denied Even Though the Username/Password Pair Is Correct.** Some reasons for denial include the following parameters controlled by your TACACS+ server application:

- The account has expired.
- The access attempt is through a port that is not allowed for the account.
- The time quota for the account has been exhausted.
- The time credit for the account has expired.
- The access attempt is outside of the timeframe allowed for the account.
- The allowed number of concurrent logins for the account has been exceeded

For more help, refer to the documentation provided with your TACACS+ server application.

**Unknown Users Allowed to Login to the Switch.** Your TACACS+ application may be configured to allow access to unknown users by assigning them the privileges included in a *default user* profile. Refer to the documentation provided with your TACACS+ server application.

**System Allows Fewer Login Attempts than Specified in the Switch Configuration.** Your TACACS+ server application may be configured to allow fewer login attempts than you have configured in the switch with the **aaa authentication num-attempts** command.

## TimeP, SNTP, or Gateway Problems

### **The Switch Cannot Find the Time Server or the Configured Gateway .**

TimeP, SNTP, and Gateway access are through the primary VLAN, which in the default configuration is the DEFAULT\_VLAN. If the primary VLAN has been moved to another VLAN, it may be disabled or does not have ports assigned to it.

## VLAN-Related Problems

**Monitor Port.** When using the monitor port in a multiple VLAN environment, the switch handles broadcast, multicast, and unicast traffic output from the monitor port as follows:

- If the monitor port is configured for tagged VLAN operation on the same VLAN as the traffic from monitored ports, the traffic output from the monitor port carries the same VLAN tag.
- If the monitor port is configured for untagged VLAN operation on the same VLAN as the traffic from the monitored ports, the traffic output from the monitor port is untagged.
- If the monitor port is not a member of the same VLAN as the traffic from the monitored ports, traffic from the monitored ports does not go out the monitor port.

**None of the devices assigned to one or more VLANs on an 802.1Q-compliant switch are being recognized.** If multiple VLANs are being used on ports connecting 802.1Q-compliant devices, inconsistent VLAN IDs may have been assigned to one or more VLANs. For a given VLAN, the same VLAN ID must be used on all connected 802.1Q-compliant devices.

**Link Configured for Multiple VLANs Does Not Support Traffic for One or More VLANs.** One or more VLANs may not be properly configured as “Tagged” or “Untagged”. A VLAN assigned to a port connecting two 802.1Q-compliant devices must be configured the same on both ports. For example, VLAN\_1 and VLAN\_2 use the same link between switch “X” and switch “Y”.

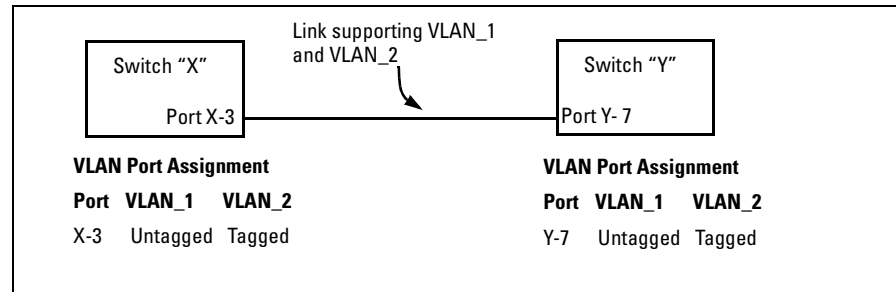

**Figure C-3. Example of Correct VLAN Port Assignments on a Link**

1. If VLAN\_1 (VID=1) is configured as “Untagged” on port 3 on switch “X”, then it must also be configured as “Untagged” on port 7 on switch “Y”. Make sure that the VLAN ID (VID) is the same on both switches.
2. Similarly, if VLAN\_2 (VID=2) is configured as “Tagged on the link port on switch “A”, then it must also be configured as “Tagged” on the link port on switch “B”. Make sure that the VLAN ID (VID) is the same on both switches.

**Duplicate MAC Addresses Across VLANs.** The Switch 4108GL operates with multiple forwarding databases. Thus, duplicate MAC addresses occurring on different VLANs can appear where a device having one MAC address is a member of more than one 802.1Q VLAN, and the switch port to which the device is linked is using VLANs (instead of STP or trunking) to establish redundant links to another switch. If the other device sends traffic over multiple VLANs, its MAC address will consistently appear in multiple VLANs on the switch port to which it is linked.

Note that attempting to create redundant paths through the use of VLANs will cause problems with some switches. One symptom is that a duplicate MAC address appears in the Port Address Table of one port, and then later appears on another port. While the Switch 4108GL has multiple forwarding databases, and thus does not have this problem, some switches with a single forwarding database for all VLANs may produce the impression that a connected device

is moving among ports because packets with the same MAC address but different VLANs are received on different ports. You can avoid this problem by creating redundant paths using port trunks or spanning tree.

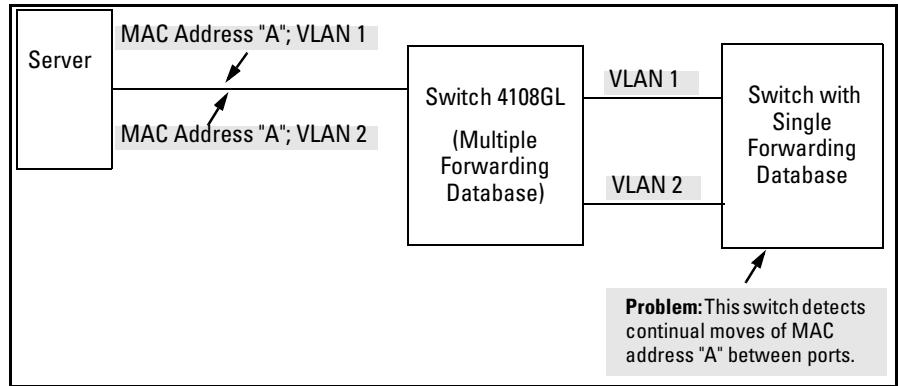

**Figure C-4. Example of Duplicate MAC Address**

## Using the Event Log To Identify Problem Sources

The Event Log records operating events as single-line entries listed in chronological order, and serves as a tool for isolating problems. Each Event Log entry is composed of five fields:

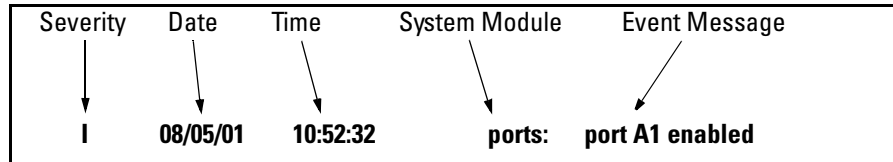

**Figure C-5. Anatomy of an Event Log Message**

**Severity** is one of the following codes:

- I** (information) indicates routine events.
- W** (warning) indicates that a service has behaved unexpectedly.
- C** (critical) indicates that a severe switch error has occurred.
- D** (debug) reserved for HP internal diagnostic information.

**Date** is the date in *mm/dd/yy* format that the entry was placed in the log.

**Time** is the time in *hh:mm:ss* format that the entry was placed in the log.

**System Module** is the internal module (such as “ports” for port manager) that generated the log entry. If VLANs are configured, then a VLAN name also appears for an event that is specific to an individual VLAN. Table C-1 on page C-22 lists the individual modules.

**Event Message** is a brief description of the operating event.

The event log holds up to 1000 lines in chronological order, from the oldest to the newest. Each line consists of one complete event message. Once the log has received 1000 entries, it discards the current oldest line each time a new line is received. The event log window contains 14 log entry lines and can be positioned to any location in the log.

The event log will be *erased* if power to the switch is interrupted.

(The event log is *not* erased by using the **Reboot Switch** command in the Main Menu.)

**Table C-1. Event Log System Modules**

Module	Event Description	Module	Event Description
addrMgr	Address table	mgr	Console management
chassis	switch hardware	ports	Change in port status; static trunks
bootp	bootp addressing	snmp	SNMP communications
console	Console interface	stack	Stacking
dhcp	DHCP addressing	stp	Spanning Tree
download	file transfer	sys, system	Switch management
FFI	Find, Fix, and Inform -- available in the console event log and web browser interface alert log	telnet	Telnet activity
garp	GARP/GVRP	tcp	Transmission control
igmp	IP Multicast	tftp	File transfer for new OS or config.
ip	IP-related	timep	Time protocol
ipx	Novell Netware	vlan	VLAN operations
lacp	Dynamic LACP trunks	Xmodem	Xmodem file transfer

## Menu: Entering and Navigating in the Event Log

From the Main Menu, select **Event Log**.

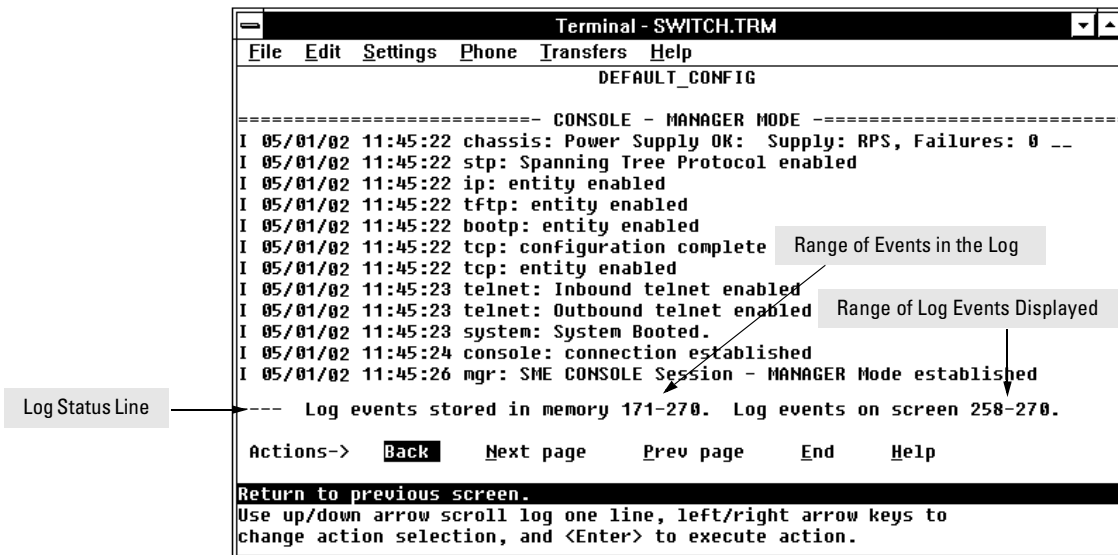

**Figure C-6. Example of an Event Log Display**



The *log status line* at the bottom of the display identifies where in the sequence of event messages the display is currently positioned.

To display various portions of the Event Log, either preceding or following the currently visible portion, use either the actions listed at the bottom of the display (**Next page**, **Prev page**, or **End**), or the keys described in the following table:

**Table C-2. Event Log Control Keys**

Key	Action
[N]	Advance the display by one page (next page).
[P]	Roll back the display by one page (previous page).
[↓]	Advance display by one event (down one line).
[↑]	Roll back display by one event (up one line).
[E]	Advance to the end of the log.
[H]	Display Help for the event log.

## CLI:

Using the CLI, you can list

- Events recorded since the last boot of the switch
- All events recorded
- Event entries containing a specific keyword, either since the last boot or all events recorded

**Syntax:** show logging [-a] [<search-text>]

HPswitch> show logging                      Lists recorded log messages since last reboot.

HPswitch> show logging -a                   Lists all recorded log messages, including those before the last reboot.

HPswitch> show logging -a system Lists log messages with "system" in the text or module name.

HPswitch> show logging system           Lists all log messages since the last reboot that have "system" in the text or module name.

## Diagnostic Tools

### Diagnostic Features

Feature	Default	Menu	CLI	Web
Port Autonegotiation	n/a	n/a	n/a	n/a
PingTest	n/a	—	page C-27	page C-26
Link Test	n/a	—	page C-27	page C-26
Display Config File	n/a	—	page C-29	page C-32
Admin. and Troubleshooting Commands	n/a	—	page C-33	—
Factory-Default Config	page C-34 (Buttons)	—	page C-34	—
Port Status	n/a	pages B-8 and B-9	pages B-8 and B-9	pages B-8 and B-9

### Port Auto-Negotiation

When a link LED does not light (indicating loss of link between two devices), the most common reason is a failure of port auto-negotiation between the connecting ports. If a link LED fails to light when you connect the switch to a port on another device, do the following:

1. Ensure that the switch port and the port on the attached end-node are both set to **Auto** mode.
2. If the attached end-node does not have an **Auto** mode setting, then you must manually configure the switch port to the same setting as the end-node port. See Chapter 9, “Optimizing Traffic Flow with Port Controls, Port Trunking, and Port-Based Priority”.

### Ping and Link Tests

The Ping test and the Link test are point-to-point tests between your switch and another IEEE 802.3-compliant device on your network. These tests can tell you whether the switch is communicating properly with another device.

---

**Note**

---

To respond to a Ping test or a Link test, the device you are trying to reach must be IEEE 802.3-compliant.

**Ping Test.** This is a test of the path between the switch and another device on the same or another IP network that can respond to IP packets (ICMP Echo Requests).

**Link Test.** This is a test of the connection between the switch and a designated network device on the same LAN (or VLAN, if configured). During the link test, IEEE 802.2 test packets are sent to the designated network device in the same VLAN or broadcast domain. The remote device must be able to respond with an 802.2 Test Response Packet.

## Web: Executing Ping or Link Tests

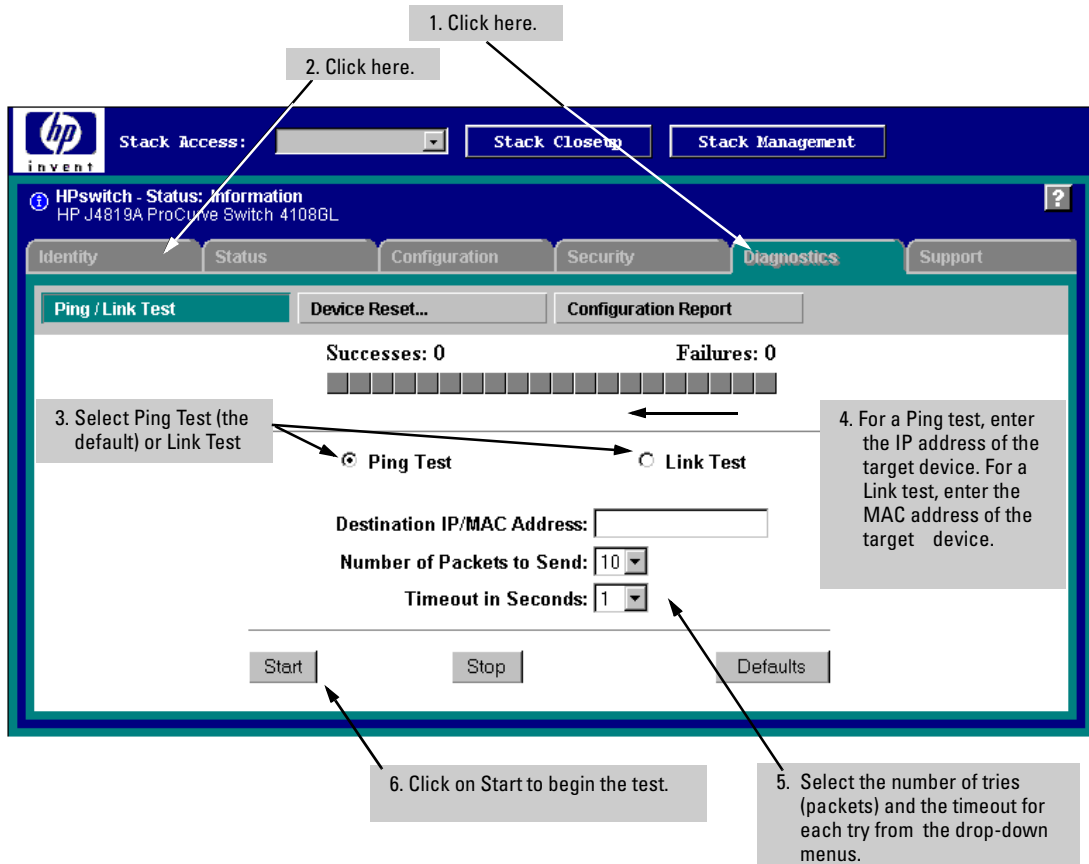

**Figure C-7. Link and Ping Test Screen on the Web Browser Interface**

**Successes** indicates the number of Ping or Link packets that successfully completed the most recent test.

**Failures** indicates the number of Ping or Link packets that were unsuccessful in the last test. Failures indicate connectivity or network performance problems (such as overloaded links or devices).

**Destination IP/MAC Address** is the network address of the target, or destination, device to which you want to test a connection with the switch. An IP address is in the X.X.X.X format where X is a decimal number between 0 and 255. A MAC address is made up of 12 hexadecimal digits, for example, 0060b0-080400.

**Number of Packets to Send** is the number of times you want the switch to attempt to test a connection.

**Timeout in Seconds** is the number of seconds to allow per attempt to test a connection before determining that the current attempt has failed.

**To halt a Link or Ping test** before it concludes, click on the Stop button.  
**To reset the screen** to its default settings, click on the Defaults button.

## CLI: Ping or Link Tests

**Ping Tests.** You can issue single or multiple ping tests with varying repetitions and timeout periods. The defaults and ranges are:

- Repetitions: 1 (1 - 999)
- Timeout: 5 seconds (1 - 256 seconds)

**Syntax:** ping <ip-address> [repetitions <1 - 999>] [timeout <1 - 256>]

Basic Ping Operation	→	HPswitch>ping 10.28.227.103 10.28.227.103 is alive, time = 15 ms
Ping with Repetitions	→	HPswitch>ping 10.28.227.103 repetitions 3 10.28.227.103 is alive, iteration 1, time = 15 ms 10.28.227.103 is alive, iteration 2, time = 15 ms 10.28.227.103 is alive, iteration 3, time = 15 ms
Ping with Repetitions and Timeout	→	HPswitch>ping 10.28.227.103 repetitions 3 timeout 2 10.28.227.103 is alive, iteration 1, time = 15 ms 10.28.227.103 is alive, iteration 2, time = 10 ms 10.28.227.103 is alive, iteration 3, time = 15 ms
Ping Failure	↘	HPswitch> ping 10.28.227.105 Target did not respond.

**Figure C-8. Examples of Ping Tests**

To halt a ping test before it concludes, press **Ctrl** **C**.

**Link Tests.** You can issue single or multiple link tests with varying repetitions and timeout periods. The defaults are:

- Repetitions: 1 (1 - 999)
- Timeout: 5 seconds (1 - 256 seconds)

**Syntax:** link <mac-address> [repetitions <1 - 999>] [timeout <1 - 256>]  
[vlan <vlan-id>]

Basic Link Test	HPswitch#link 0030c1-7fcc40 Link-test passed.
Link Test with Repetitions	HPswitch#link 0030c1-7fcc40 repetitions 3 802.2 TEST packets sent: 3, responses received: 3
Link Test with Repetitions and Timeout	HPswitch#link 0030c1-7fcc40 repetitions 3 timeout 1 802.2 TEST packets sent: 3, responses received: 3
Link Test Over a Specific VLAN	HPswitch#link 0030c1-7fcc40 repetitions 3 timeout 1 vlan 1 802.2 TEST packets sent: 3, responses received: 3
Link Test Over a Specific VLAN; Test Fail	HPswitch#link 0030c1-7fcc40 repetitions 3 timeout 1 vlan 222 802.2 TEST packets sent: 3, responses received: 0

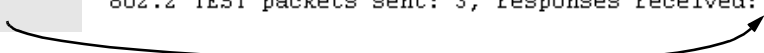

**Figure C-9. Example of Link Tests**

## Displaying the Configuration File

The complete switch configuration is contained in a file that you can browse from either the web browser interface or the CLI. It may be useful in some troubleshooting scenarios to view the switch configuration.

### CLI: Viewing the Configuration File

Using the CLI, you can display either the running configuration or the startup configuration. (For more on these topics, see appendix C, "Switch Memory and Configuration".)

<b>Syntax:</b>	write terminal	Displays the running-config file.
	show running-config	Displays the running-config file.
	show config	Displays the startup-config file.

# Listing Switch Configuration and Operation Details for Help in Troubleshooting

Release G.04.05 and greater includes the **show tech** command. This command outputs, in a single listing, switch operating and running configuration details from several internal switch sources, including:

- Image stamp (software version data)
- Running configuration
- Event Log listing
- Boot History
- Port settings
- Status and counters — port status
- IP routes
- Status and counters — VLAN information
- GVRP support
- Load balancing (trunk and LACP)
- Stacking status — this switch
- Stacking status — all

**Syntax:** show tech

Executing **show tech** outputs a data listing to your terminal emulator. However, using your terminal emulator's text capture features, you can also save **show tech** data to a text file for viewing, printing, or sending to an associate. For example, if your terminal emulator is the Hyperterminal application available with Microsoft® Windows® software, you can copy the show tech output to a file and then use either Microsoft Word or Notepad to display the data. (In this case, Microsoft Word provides the data in an easier-to-read format.)

**To Copy show tech output to a Text File.** This example uses the Microsoft Windows terminal emulator. To use another terminal emulator application, refer to the documentation provided with that application.



1. In Hyperterminal, click on **Transfer | Capture Text...**

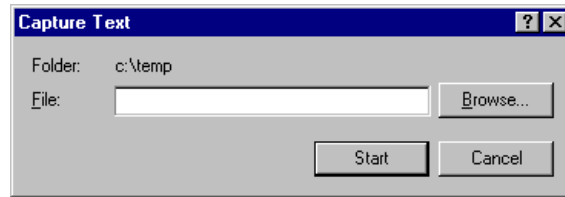

**Figure C-10. The Capture Text window of the Hypertext Application Used with Microsoft Windows Software**

2. In the **File** field, enter the path and file name under which you want to store the **show tech** output.

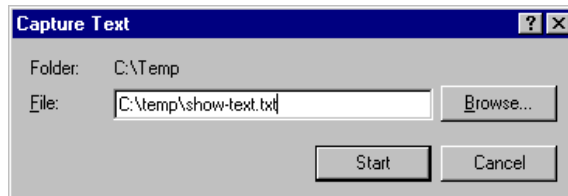

**Figure C-11. Example of a Path and Filename for Creating a Text File from show tech Output**

3. Click **Start** to create and open the text file.
4. Execute **show tech**:

```
HPswitch# show tech
```

  - a. Each time the resulting listing halts and displays `-- MORE --`, press the Space bar to resume the listing.
  - b. When the CLI prompt appears, the show tech listing is complete. At this point, click on **Transfer | Capture Text | Stop** in HyperTerminal to stop copying data into the text file created in the preceding steps.

---

**Note**

Remember to do the above step to stop HyperTerminal from copying into the text file. Otherwise, the text file remains open to receiving additional data from the HyperTerminal screen.

5. To access the file, open it in Microsoft Word, Notepad, or a similar text editor.

## Troubleshooting

Listing Switch Configuration and Operation Details for Help in Troubleshooting

### Web: Viewing the Configuration File

To display the running configuration, through the web browser interface:

1. Click on the **Diagnostics** tab.
2. Click on `Configuration Report`
3. Use the right-side scroll bar to scroll through the configuration listing.

## CLI Administrative and Troubleshooting Commands

These commands provide information or perform actions that you may find helpful in troubleshooting operating problems with the switch.

---

**Note**

---

For more on the CLI, refer to chapter 3, "Using the Command Line Reference (CLI)."

<b>Syntax:</b>	show version	Shows the software version currently running on the switch, and the flash image from which the switch booted (primary or secondary).
	show boot-history	Displays the switch shutdown history.
	show history	Displays the current command history.
	[no] page	Toggles the paging mode for display commands between continuous listing and per-page listing.
	setup	Displays the Switch Setup screen from the menu interface
	repeat	Repeatedly executes the previous command until a key is pressed.
	kill	Terminates all other active sessions.

## Restoring the Factory-Default Configuration

As part of your troubleshooting process, it may become necessary to return the switch configuration to the factory default settings. This process momentarily interrupts the switch operation, clears any passwords, clears the console event log, resets the network counters to zero, performs a complete self test, and reboots the switch into its factory default configuration including deleting an IP address. There are two methods for restoring to the factory-default configuration:

- CLI
- Clear/Reset button combination

---

### Note

HP recommends that you save your configuration to a TFTP server before resetting the switch to its factory-default configuration. You can also save your configuration via Xmodem, to a directly connected PC.

### CLI: Resetting to the Factory-Default Configuration

This command operates at any level *except* the Operator level.

**Syntax:** `erase startup-configuration`      Deletes the startup-config file in flash so that the switch will reboot with its factory-default configuration.

---

### Note

The **erase startup-config** command does not clear passwords.

### Clear/Reset: Resetting to the Factory-Default Configuration

To execute the factory default reset, perform these steps:

1. Using pointed objects, simultaneously press both the Reset and Clear buttons on the front of the switch.
2. Continue to press the Clear button while releasing the Reset button.
3. When the Self Test LED begins to flash, release the Clear button.

The switch will then complete its self test and begin operating with the configuration restored to the factory default settings.

## Restoring a Flash Image

The switch can lose its operating system if either the primary or secondary flash image location is empty or contains a corrupted OS file and an operator uses the **erase flash** command to erase a good OS image file from the opposite flash location.

**To Recover from an Empty or Corrupted Flash State.** Use the switch's console serial port to connect to a workstation or laptop computer that has the following:

- A terminal emulator program with Xmodem capability, such as the HyperTerminal program included in Windows PC software.
- A copy of a good OS image file for the switch.

---

### Note

The following procedure requires the use of Xmodem, and copies an OS image into primary flash only.

This procedure assumes you are using HyperTerminal as your terminal emulator. If you use a different terminal emulator, you may need to adapt this procedure to the operation of your particular emulator.

1. Start the terminal emulator program.
2. Ensure that the terminal program is configured as follows:
  - Baud rate: 9600
  - 1 stop bit
  - No parity
  - No flow control
  - 8 Bits
3. Use the Reset button to reset the switch. The following prompt should then appear in the terminal emulator:

```
Enter h or ? for help.
```

```
=>
```

4. Since the OS file is large, you can increase the speed of the download by changing the switch console and terminal emulator baud rates to a high speed. For example:
  - a. Change the switch baud rate to 115,200 Bps.  
  
=> sp 115200
  - b. Change the terminal emulator baud rate to match the switch speed:
    - i. In HyperTerminal, select **Call | Disconnect**.
    - ii. Select **File | Properties**.
    - iii. click on **[Configure...]**.
    - iv. Change the baud rate to **115200**.
    - v. Click on **[OK]**. In the next window, click on **[OK]** again.
    - vi. Select **Call | Connect**
    - vii. Press **[Enter]** one or more times to display the => prompt.
5. Start the Console Download utility by typing **do** at the => prompt and pressing **[Enter]**:

=> do

6. You will then see this prompt:

```
You have invoked the console download utility.  
Do you wish to continue? (Y/N)>_
```

7. At the above prompt:
  - a. Type **Y** (for Yes)
  - b. Select **Transfer | File** in HyperTerminal.
  - c. Enter the appropriate filename and path for the OS image.
  - d. Select the **Xmodem** protocol (and not the 1k Xmodem protocol).
  - e. Click on **[Send]**.

If you are using HyperTerminal, you will see a screen similar to the following to indicate that the download is in progress:

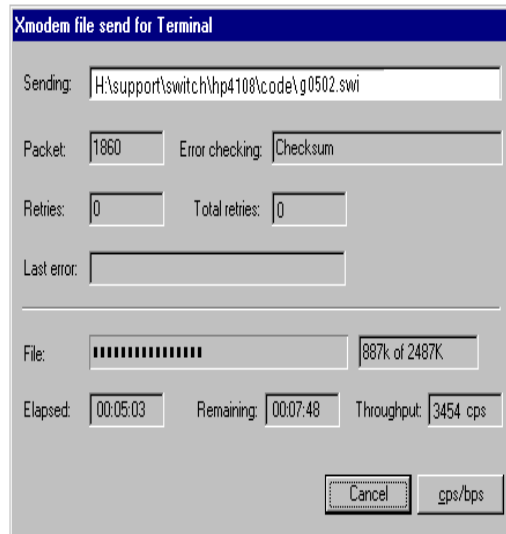

**Figure C-12. Example of Xmodem Download in Progress**

8. When the download completes, the switch reboots from primary flash using the OS image you downloaded in the preceding steps, plus the most recent startup-config file.

**Troubleshooting**  
Restoring a Flash Image



# MAC Address Management

---

## Overview

The switch assigns MAC addresses in these areas:

- For management functions:
  - One Base MAC address assigned to the default VLAN (VID = 1)
  - Additional MAC address(es) corresponding to additional VLANs you configure in the switch
- For internal switch operations: One MAC address per port (See "CLI: Viewing the Port and VLAN MAC Addresses" on page D-4.)

MAC addresses are assigned at the factory. The switch automatically implements these addresses for VLANs and ports as they are added to the switch.

---

**Note**

---

The switch's base MAC address is also printed on a label affixed to the back of the switch.

## Determining MAC Addresses

### MAC Address Viewing Methods

Feature	Default	Menu	CLI	Web
view switch's base (default vlan) MAC address and the addressing for any added VLANs	n/a	D-3	D-4	—
view port MAC addresses (hexadecimal format)	n/a	—	D-4	—

- **Use the menu interface** to view the switch's base MAC address and the MAC address assigned to any non-default VLAN you have configured on the switch.

---

### Note

---

The switch's base MAC address is used for the default VLAN (VID = 1) that is always available on the switch.

- **Use the CLI** to view the switch's port MAC addresses in hexadecimal format.

## Menu: Viewing the Switch's MAC Addresses

The Management Address Information screen lists the MAC addresses for:

- Base switch (default VLAN; VID = 1)
- Any additional VLANs configured on the switch.

Also, the Base MAC address appears on a label on the back of the switch.

---

### Note

The Base MAC address is used by the first (default) VLAN in the switch. This is usually the VLAN named "DEFAULT\_VLAN" unless the name has been changed (by using the VLAN Names screen). On the Switch 4108GL, the VID (VLAN identification number) for the default VLAN is always "1", and cannot be changed.

---

### To View the MAC Address (and IP Address) assignments for VLANs Configured on the Switch:

1. From the Main Menu, Select

1. Status and Counters

2. Switch Management Address Information

If the switch has only the default VLAN, the following screen appears. If the switch has multiple static VLANs, each is listed with its address data.

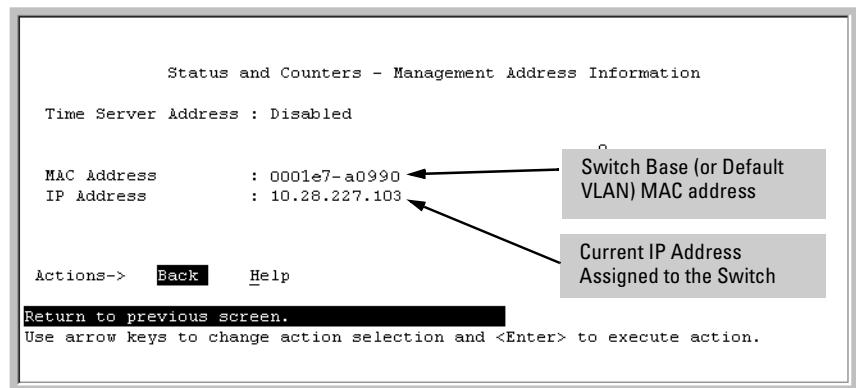

Figure D-1. Example of the Management Address Information Screen

## CLI: Viewing the Port and VLAN MAC Addresses

The MAC address assigned to each switch port is used internally by such features as Flow Control and the Spanning Tree Protocol. Using the **walkmib** command to determine the MAC address assignments for individual ports can sometimes be useful when diagnosing switch operation.

The switch allots 24 MAC addresses per slot. For a given slot, if a three-port module is installed, then the switch uses the first three MAC addresses in the allotment for slot 1, and the remaining 21 MAC addresses are unused. If a six-port module is installed, the switch uses the first six MAC addresses in the allotment, and so-on. The switch's base MAC address is assigned to VLAN (VID) 1 and appears in the **walkmib** listing after the MAC addresses for the ports. If multiple VLANs are configured, the MAC addresses assigned to these VLANs appear after the base MAC address.

To display the switch's MAC addresses, use the **walkmib** command at the command prompt:

---

### Note

---

This procedure displays the MAC addresses for all ports and existing VLANs in the switch, regardless of which VLAN you select.

1. If the switch is at the CLI Operator level, use the **enable** command to enter the Manager level of the CLI.
2. Type the following command to display the MAC address for each port on the switch:

```
HP4108# walkmib ifPhysAddress
```

(The above command is not case-sensitive.)

For example, with a six-port module in slot 1, a three-port module in slot 3, and three VLANs present:

<pre> HPswitch# walkmib ifPhysAddress ifPhysAddress.1 = 00 01 e7 a0 99 ff ifPhysAddress.2 = 00 01 e7 a0 99 fe ifPhysAddress.3 = 00 01 e7 a0 99 fd ifPhysAddress.4 = 00 01 e7 a0 99 fc ifPhysAddress.5 = 00 01 e7 a0 99 fb ifPhysAddress.6 = 00 01 e7 a0 99 fa ifPhysAddress.49 = 00 01 e7 a0 99 cf ifPhysAddress.50 = 00 01 e7 a0 99 ce ifPhysAddress.51 = 00 01 e7 a0 99 cd ifPhysAddress.205 = 00 01 e7 a0 99 00 ifPhysAddress.226 = 00 01 e7 a0 99 01 ifPhysAddress.237 = 00 01 e7 a0 99 02         </pre>	<p>ifPhysAddress.1 - 6: Ports A1 - A6 in Slot 1                  (Addresses 7 - 24 in slot 1 and 25 - 48 in slot 2 are unused.)</p> <p>ifPhysAddress.49 - 51: Ports C1 - C3 in Slot 3                  (Addresses 52 - 72 in slot 3 are unused.)</p> <p>ifPhysAddress.205: Base MAC Address (MAC Address for default VLAN; VID = 1)</p> <p>ifPhysAddress.226 &amp; 237: MAC Addresses for non-default VLANs.</p>
---	--

**Figure D-2. Example of Port MAC Address Assignments**

**MAC Address Management**  
Determining MAC Addresses

# Daylight Savings Time on HP Procurve Switches

---

This information applies to the following HP Procurve switches:

- 2512
- 2524
- 4108GL
- 4104GL
- 5304XL
- 5308XL
- 1600M
- 2400M
- 2424M
- 4000M
- 8000M
- 212M
- 224M
- HP AdvanceStack Switches
- HP AdvanceStack Routers

HP Procurve switches provide a way to automatically adjust the system clock for Daylight Savings Time (DST) changes. To use this feature you define the month and date to begin and to end the change from standard time. In addition to the value "none" (no time changes), there are five pre-defined settings, named:

- Alaska
- Canada and Continental US
- Middle Europe and Portugal
- Southern Hemisphere
- Western Europe

The pre-defined settings follow these rules:

**Alaska:**

- Begin DST at 2am the first Sunday on or after April 24th.
- End DST at 2am the first Sunday on or after October 25th.

**Canada and Continental US:**

- Begin DST at 2am the first Sunday on or after April 1st.
- End DST at 2am the first Sunday on or after October 25th.

**Middle Europe and Portugal:**

- Begin DST at 2am the first Sunday on or after March 25th.
- End DST at 2am the first Sunday on or after September 24th.

**Southern Hemisphere:**

- Begin DST at 2am the first Sunday on or after October 25th.
- End DST at 2am the first Sunday on or after March 1st.

**Western Europe:**

- Begin DST at 2am the first Sunday on or after March 23rd.
- End DST at 2am the first Sunday on or after October 23rd.

A sixth option named "User defined" allows you to customize the DST configuration by entering the beginning month and date plus the ending month and date for the time change. The menu interface screen looks like this (all month/date entries are at their default values):

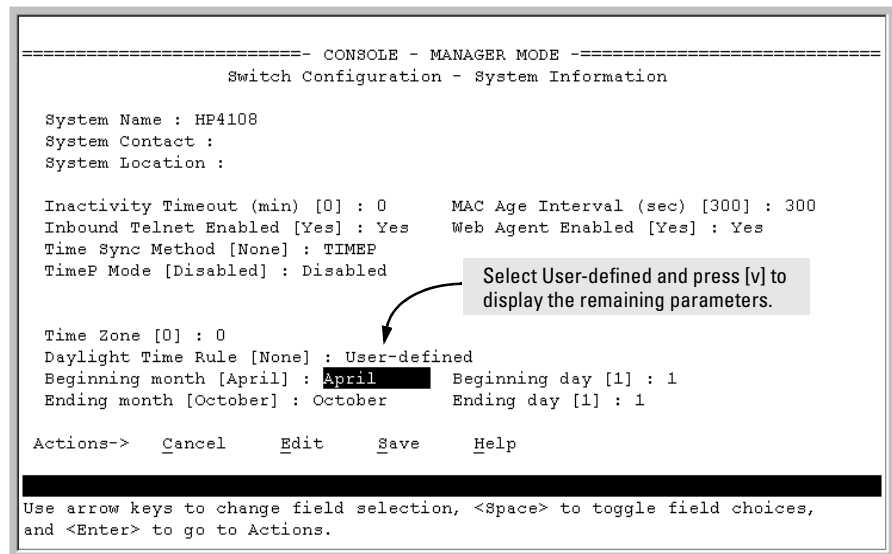

**Figure 5-1. Menu Interface with "User-Defined" Daylight Time Rule Option**



Before configuring a "User defined" Daylight Time Rule, it is important to understand how the switch treats the entries. The switch knows which dates are Sundays, and uses an algorithm to determine on which date to change the system clock, given the configured "Beginning day" and "Ending day":

- If the configured day is a Sunday, the time changes at 2am on that day.
- If the configured day is not a Sunday, the time changes at 2am on the first Sunday after the configured day.

This is true for both the "Beginning day" and the "Ending day".

With that algorithm, one should use the value "1" to represent "first Sunday of the month", and a value equal to "number of days in the month minus 6" to represent "last Sunday of the month". This allows a single configuration for every year, no matter what date is the appropriate Sunday to change the clock.



# Index

## Symbols

=> prompt ... C-35

## Numerics

802.1Q VLAN standard ... 13-3

802.3u auto negotiation standard ... 9-3

## A

A.09.70 router release ... 11-32

access

manager ... 10-4

operator ... 10-4

Actions line ... 2-9, 2-10, 2-11

location on screen ... 2-9

active path ... 13-3

address table, port ... B-13

address, network manager ... 10-3

advertisement ... 11-33

alert log ... 4-19

alert types ... 4-20

disabling ... 4-24

setting the sensitivity level ... 4-23

sorting the entries ... 4-19

analysis, traffic ... 10-2

APNIC ... 7-18

Asia-Pacific NIC ... 7-18

asterisk ... 2-10, 2-13

authentication trap ... 10-8, 10-11

See also *SNMP*.

authentication trap, configuring ... 10-11

authorized IP managers

SNMP, blocking ... 10-2

auto

See *GVRP*.

auto negotiation ... 9-4

auto port setting ... 12-5

Auto-10 ... 9-11, 9-14

auto-discovery ... 10-4

auto-negotiation ... 9-3

## B

bandwidth

displaying utilization ... 4-16

blocked link from STP operation ... 13-5

blocked port

from IGMP operation ... 12-5

from STP operation ... 13-4

boot ROM console ... A-3

boot ROM mode ... C-35

Bootp ... 7-3, 7-10, 10-2

Bootp table file ... 7-12

Bootptab file ... 7-12

effect of no reply ... C-6

gateway ignored ... 11-7

operation ... 7-12

using with Unix systems ... 7-12

Bootp/DHCP differences ... 7-11

BPDU ... 11-33, 13-3, 13-5

bridge protocol data unit ... 11-33

broadcast domain ... 11-3

broadcast limit ... 9-4, 9-9

broadcast storm ... 9-11, 13-3, 13-7, C-14

browser interface

See *web browser interface*.

## C

CDP

CDP on hubs ... 10-29

configuration ... 10-19, 10-22

configuration, viewing ... 10-20

default CDP operation ... 10-19

effect of spanning tree ... 10-24

factory-default ... 10-19

general operation ... 10-15

hold time ... 10-24

IP address in outbound packet ... 10-25

mib objects ... 10-26

neighbor ... 10-14

neighbor data ... 10-26

neighbor maximum ... 10-28

neighbor table ... 10-18

neighbors table ... 10-20

neighbors table, resetting ... 10-21

- on individual ports ... 10-23
  - overview of operation ... 10-13
  - port trunking ... 10-28
  - requirements ... 10-13
  - terminology ... 10-14
  - transmission interval ... 10-24
  - transparent devices ... 10-18
  - troubleshooting ... C-7
  - version data ... 10-28
  - Class of Service
    - priority settings mapped to downstream devices ... 9-34
  - Clear button ... 4-11
    - restoring factory default configuration ... C-34
  - CLI
    - configuring RSTP ... 13-10
    - context level ... 9-8
  - command line interface
    - See *CLI*.
  - communities, SNMP ... 10-5
  - configuration ... 2-7, 13-4
    - Bootp ... 7-12
    - comparing startup to running ... 5-5
    - console ... 6-3
    - copying ... A-13
    - download ... A-3
    - factory default ... 5-8, 7-2, 11-10, 11-15, 13-4
    - IP ... 7-3
    - network monitoring ... B-23
    - permanent ... 5-6
    - permanent change defined ... 5-4
    - port ... 9-1
    - port trunk groups ... 9-1
    - quick ... 2-8
    - reboot to activate ... 2-13
    - restoring factory defaults ... C-34
    - RSTP
      - from the CLI ... 13-10
      - from the menu ... 13-16
      - per-port parameters ... 13-14
      - whole switch parameters ... 13-12
    - saving from menu interface ... 2-10
    - serial link ... 6-3
    - SNMP ... 10-3, 10-4
    - spanning tree protocol ... 13-4
    - startup ... 2-10
    - system ... 6-9
    - Telnet access configuration ... 6-3
    - transferring ... A-13
    - trap receivers ... 10-8
    - viewing ... 5-5
    - VLAN ... 11-3
    - web browser access ... 6-3
  - configuration file
    - browsing for troubleshooting ... C-29
  - configuring RSTP ... 13-9
  - console ... C-6
    - configuring ... 6-3
    - ending a session ... 2-5
    - features ... 1-3
    - Main menu ... 2-7
    - navigation ... 2-9, 2-10
    - operation ... 2-10
    - starting a session ... 2-4
    - status and counters access ... 2-7
    - troubleshooting access problems ... C-4
  - context level
    - global config ... 7-8
  - CPU utilization ... B-5
- ## D
- date format ... C-21
  - date,configure ... 6-13
  - dedicated management VLAN ... 11-6
  - default gateway ... 7-3
  - default trunk type ... 9-17
  - Device Passwords Window ... 4-8
  - DHCP ... 7-10, 10-2
    - address problems ... C-6
    - effect of no reply ... C-6
    - gateway ignored ... 11-7
  - DHCP/Bootp differences ... 7-11
  - DHCP/Bootp process ... 7-11
  - diagnostics tools ... C-24
    - browsing the configuration file ... C-29
    - ping and link tests ... C-24
  - DNS name ... 4-5
  - domain ... 11-10, 11-15
  - Domain Name Server ... 4-5
  - download
    - SNMP-based ... A-11
    - switch-to-switch ... A-9
    - troubleshooting ... A-12
    - Xmodem ... A-6
  - download OS ... A-9

- download, TFTP ... A-3, A-4
- downstream device (QoS)
  - effect of priority settings ... 9-34
- duplicate MAC address
  - See *MAC address*.
- Dyn1
  - See *LACP*.

## E

- enabling RSTP
  - CLI ... 13-11
  - menu interface ... 13-16
  - web browser interface ... 13-18
- Enabling STP
  - CLI ... 13-11
- ending a console session ... 2-5
- event log ... 2-7, C-21
  - navigation ... C-22
  - severity level ... C-21
  - use during troubleshooting ... C-21

## F

- factory default configuration
  - restoring ... 5-8, C-34
- failure, OS download ... A-12
- Fast EtherChannel
  - See *FEC*.
- fast mode
  - spanning tree ... 13-20, 13-26
- fault detection ... 4-8
- fault detection policy ... 4-8, 4-23
- fault detection policy, setting ... 4-23
- fault detection window ... 4-23
- fault-tolerance ... 9-12
- FEC
  - benefits ... 9-30
- filters
  - effect of IGMP ... 12-20
  - maximum allowed ... 12-20
- firmware version ... B-5
- flash memory ... 2-10, 5-2
- flow control ... 9-4
- flow control, status ... B-9
- flow control, terminal ... 6-3
- forbid
  - See *GVRP*.

- format, date ... C-21
- format, time ... C-21
- forwarding port, IGMP ... 12-5
- friendly port names
  - See *port names, friendly*.

## G

- GARP
  - See *GVRP*.
- gateway ... 7-3, 7-5
- gateway (IP) address ... 7-4, 7-6
- gateway, manual config ... 11-7
- global config level ... 7-8
- GVRP
  - advertisement ... 11-47
  - advertisement, defined ... 11-33
  - advertisement, responses to ... 11-35
  - advertisements, generating ... 11-40
  - auto ... 11-39
  - benefit ... 11-33
  - block ... 11-37
  - CLI, configuring ... 11-43
  - configurable port options ... 11-36
  - configuring learn, block, disable ... 11-37
  - convert dynamic to static ... 11-36
  - converting to static VLAN ... 11-33
  - disable ... 11-37
  - dynamic VLAN and reboots ... 11-47
  - dynamic VLANs always tagged ... 11-34
  - forbid ... 11-39
  - GARP ... 11-33
  - general operation ... 11-34
  - IP addressing ... 11-36
  - learn ... 11-37
  - learn, block, disable ... 11-39
  - menu, configuring ... 11-42
  - non-GVRP aware ... 11-47
  - non-GVRP device ... 11-47
  - operating notes ... 11-46
  - port control options ... 11-40
  - port-leave from dynamic ... 11-40
  - reboot, switch ... 11-40
  - recommended tagging ... 11-40
  - standard ... 11-33
  - tagged, dynamic VLAN ... 11-34
  - unknown VLAN ... 11-40
  - unknown VLAN, options ... 11-36

- VLAN behavior ... 11-7
- VLAN, dynamic adds ... 11-13
- VLAN, maximum ... 11-46

## H

- Help ... 2-11, 4-13
- Help line, about ... 2-9
- Help line, location on screens ... 2-9
- help, online inoperable ... 4-13
- HP Procurve
  - support URL ... 4-13
- HP Router 440 ... 11-32
- HP Router 470 ... 11-32
- HP Router 480 ... 11-32
- HP Router 650 ... 11-32
- HP TopTools
  - See *TopTools*.
- HP web browser interface ... 1-5

## I

- ICANN ... 7-18
- IEEE 802.1d ... C-14
- IEEE 802.3ab ... 9-4
- IGMP
  - benefits ... 12-3
  - configuration ... 12-10
  - configure per VLAN ... 12-5
  - effect on filters ... 12-20
  - high-priority forwarding ... 12-5
  - host not receiving ... C-8
  - IP multicast address range ... 12-20
  - leave group ... 12-11
  - maximum address count ... 12-20
  - multicast group ... 12-11
  - multimedia ... 12-3
  - not working ... C-8
  - operation ... 12-11, 12-12
  - port states ... 12-5
  - query ... 12-11
  - report ... 12-11
  - statistics ... B-19
  - status ... 12-12
  - traffic ... 12-5
- inactivity timeout ... 6-4
- Inbound Telnet Enabled parameter ... C-5
- interfaces listed ... 1-2

- invalid input ... 3-13

## IP

- CLI access ... 7-7
- configuration ... 7-3
- DHCP/Bootp ... 7-3
- duplicate address ... C-6
- duplicate address, DHCP network ... C-6
- effect when address not used ... 7-9
- gateway ... 7-3, 11-7
- gateway (IP) address ... 7-4
- global assignment ... 7-18
- globally assigned addressing ... 7-18
- menu access ... 7-5
- stacking ... 7-5
- subnet mask ... 7-3, 7-6
- using for web browser interface ... 4-5
- web access ... 7-9

### IP preserve

- DHCP server ... 7-14
- overview ... 7-14
- rules, operating ... 7-14
- summary of effect ... 7-17

### IP, for SNMP ... 10-2

## IPX

- network number ... B-6

## J - L

- Java ... 4-4, 4-5
- kill command ... 6-8
- LACP
  - 802.1x, not allowed ... 9-28
  - active ... 9-23, 9-26
  - CLI access ... 9-18
  - default port operation ... 9-27
  - described ... 9-13, 9-25
  - Dyn1 ... 9-14
  - dynamic ... 9-26
  - enabling dynamic trunk ... 9-23
  - full-duplex required ... 9-4, 9-11, 9-25
  - IGMP ... 9-29
  - no half-duplex ... 9-30
  - operation not allowed ... C-9
  - outbound traffic distribution ... 9-31
  - overview ... 9-12
  - passive ... 9-23, 9-26
  - removing port from active trunk ... 9-24
  - restrictions ... 9-28

- standby link ... 9-26
- status, terms ... 9-27
- STP ... 9-29
- VLANs ... 9-29
  - with 802.1x ... 9-28
  - with port security ... 9-28
- LACP, with CDP ... 10-28
- learning bridge ... 7-2
- leave group
  - See *IGMP*.
- legacy VLAN ... 11-5
- limit, broadcast ... 9-9
- link speed, port trunk ... 9-11
- link test ... C-25
  - for troubleshooting ... C-24
- link, serial ... 6-3
- load balancing
  - See *port trunk*.
- logical port ... 9-15
- loop, network ... 9-11, 13-3, 13-4
- lost password ... 4-11

## M

- MAC address ... 7-12, B-5, D-1
  - duplicate ... C-14, C-19
  - learned ... B-12, B-13
  - port ... D-1, D-3
  - switch ... D-1
  - VLAN ... 11-31, D-1
- management
  - interfaces described ... 1-2
  - server URL ... 4-12, 4-13
  - server URL default ... 4-14
- management VLAN
  - See *VLAN*.
- manager access ... 10-4
- manager password ... 4-8, 4-10
- Manual, IP address ... 7-6
- maximum VLANs, GVRP ... 11-46
- media type, port trunk ... 9-11
- memory
  - flash ... 2-10, 5-2
  - startup configuration ... 2-10
- menu interface
  - configuration changes, saving ... 2-10
  - configuring RSTP ... 13-16

- message
  - VLAN already exists ... 11-21
- MIB ... 10-3
- MIB listing ... 10-3
- MIB, HP proprietary ... 10-3
- MIB, standard ... 10-3
- Microsoft Internet Explorer ... 4-4
- mirroring
  - See *port monitoring*.
- monitoring traffic ... B-23
- monitoring, traffic ... 10-2
- multicast group
  - See *IGMP*.
- multimedia
  - See *IGMP*.
- multiple VLAN ... 10-2
- multi-port bridge ... 7-2

## N

- navigation, console interface ... 2-9, 2-10
- navigation, event log ... C-23
- Netscape ... 4-4
- network management functions ... 10-4
- network manager address ... 10-3
- network monitoring
  - traffic overload ... B-23
- Network Monitoring Port screen ... B-23
- network slow ... C-6
- notes on using VLANs ... 11-9

## O

- online help ... 4-13
- online help location ... 4-13
- operation not allowed, LACP ... C-9
- operator access ... 10-4
- operator password ... 4-8, 4-10
- optimizing RSTP configuration ... 13-9
- OS
  - version ... A-5, A-7, A-10
- OS download
  - failure indication ... A-12
  - switch-to-switch download ... A-9
  - troubleshooting ... A-12
  - using TFTP ... A-3
- out-of-band ... 1-3

## P

- password ... 4-8, 4-10
  - creating ... 4-8
  - delete ... 2-7, 4-11
  - if you lose the password ... 4-11
  - lost ... 4-11
  - manager ... 4-8
  - operator ... 4-8
  - set ... 2-7
  - setting ... 4-9
  - using to access browser and console ... 4-10
- path cost ... 13-4
- Perlman, *Interconnections* ... 13-28
- ping test ... C-25
  - for troubleshooting ... C-24
- port
  - address table ... B-13
  - auto negotiation ... 9-4
  - auto, IGMP ... 12-5
  - auto-negotiation ... 9-3
  - blocked by STP operation ... 13-4
  - blocked, IGMP ... 12-5
  - broadcast limit ... 9-9
  - CLI access ... 9-6
  - context level ... 9-8
  - counters ... B-9
  - counters, reset ... B-9
  - fiber-optic ... 9-4
  - forwarding, IGMP ... 12-5
  - full-duplex, LACP ... 9-4
  - loop
  - MAC address ... D-3, D-4
  - menu access ... 9-5
  - monitoring ... 11-31
  - redundant path
    - See *port trunk*.
  - speed change, transceiver ... 9-4
  - state, IGMP control ... 12-5
  - traffic patterns ... B-9
  - utilization ... 4-16
    - web browser interface ... 4-16
    - web browser access ... 9-9
- Port Configuration ... 9-1
- port names, friendly
  - configuring ... 6-16
  - displaying ... 6-18
  - summary ... 6-15
- port security
  - port trunk restriction ... 9-11
  - trunk restriction ... 9-15
- port trunk ... 9-10
  - caution ... 9-11, 9-16, 9-24
  - CLI access ... 9-18
  - default trunk type ... 9-17
  - enabling dynamic LACP ... 9-23
  - FEC ... 9-13, 9-30
  - IGMP ... 9-15
  - LACP ... 9-4
  - LACP, full duplex required ... 9-11
  - limit ... 9-10
  - link requirements ... 9-11
  - logical port ... 9-15
  - media requirements ... 9-14
  - media type ... 9-11
  - menu access to static trunk ... 9-16
  - monitor port restrictions ... 9-15
  - nonconsecutive ports ... 9-10
  - port security restriction ... 9-15
  - removing port from static trunk ... 9-22
  - requirements ... 9-14
  - SA/DA ... 9-31
    - See also *LACP*.
  - spanning tree protocol ... 9-15
  - static trunk ... 9-14
  - static trunk, overview ... 9-12
  - STP ... 9-15
  - STP operation ... 9-14
  - traffic distribution ... 9-14
  - Trk1 ... 9-14
  - trunk (non-protocol) option ... 9-13
  - trunk option described ... 9-30
  - types ... 9-13
  - VLAN ... 9-15, 11-31
  - VLAN operation ... 9-14
  - web browser access ... 9-24
  - with fast-uplink STP ... 13-40
- port trunk group
  - interface access ... 9-1
- port-based access control
  - event log ... C-9
  - LACP not allowed ... 9-28
  - troubleshooting ... C-9
- port-based priority
  - 802.1q VLAN tagging ... 9-33
  - configuring ... 9-36



- messages ... 9-37
- overview ... 9-33
- priority/queue table ... 9-34
- requirement for continuity ... 9-35
- rules of operation ... 9-35
- troubleshooting ... 9-37
- viewing configuration ... 9-36
- power interruption, effect on event log ... C-21
- primary VLAN
  - See *VLAN*.
- priority ... 12-5
- Procurve, HP, URL ... 10-3
- prompt, => ... C-35
- public SNMP community ... 10-4

## Q

- query
  - See *IGMP*.
- quick configuration ... 2-8
- quick start ... xxiii, 7-4

## R

- reboot ... 2-8, 2-10, 2-12, 11-40
- reboot, actions causing ... 5-3
- reconfigure ... 2-10
- redundant path ... 13-4
  - spanning tree ... 13-4
- remote session, terminate ... 6-8
- report
  - See *IGMP*.
- reset ... 2-12, 5-10
- Reset button
  - restoring factory default configuration ... C-34
- reset port counters ... B-9
- resetting the switch
  - factory default reset ... C-34
- restricted access ... 10-4
- restricted write access ... 10-4
- RFC
  - See *MIB*.
- RFC 1493 ... 10-3
- RFC 1515 ... 10-3
- RIPE NCC ... 7-18
- RMON ... 10-3
- RMON groups supported ... 10-12
- router ... 11-32, 12-11

- gateway ... 7-6
- router release A.09.70 ... 11-32
- RS-232 ... 1-3
- RSTP
  - configuring ... 13-9
  - configuring per-port parameters ... 13-14
  - configuring whole switch parameters ... 13-12
  - configuring with the CLI ... 13-10
  - configuring with the menu ... 13-16
  - edge-port parameter ... 13-14
  - enabling from CLI ... 13-11
  - enabling from the menu ... 13-16
  - enabling with the web browser ... 13-18
  - mcheck parameter ... 13-14
  - optimizing the configuration ... 13-9
  - path-cost parameter ... 13-14
  - point-to-point-mac parameter ... 13-14
  - priority parameter ... 13-14
  - viewing the configuration ... 13-10
- running-config, viewing
  - See also *configuration*.

## S

- security ... 4-11, 6-3
- Self Test LED
  - behavior during factory default reset ... C-34
- serial number ... B-5
- server
  - access failure ... 13-6
- setting fault detection policy ... 4-23
- setup screen ... 1-xxiii, 7-4
- severity code, event log ... C-21
- show tech ... C-30
- slow network ... C-6
- SNMP ... 10-2
  - CLI commands ... 10-4
  - communities ... 10-3, 10-4, 10-5
  - Communities screen ... 10-4
  - community
    - configure ... 10-3
    - IP ... 10-2
    - public community ... 10-4
    - restricted access ... 10-4
    - thresholds ... 10-8
    - traps ... 10-3, 10-8
    - traps, well-known ... 10-8
  - SNMP-based download ... A-11

## SNTP

- broadcast mode ... 8-2, 8-9
  - broadcast mode, requirement ... 8-3
  - configuration ... 8-4
  - disabling ... 8-11
  - enabling and disabling ... 8-9
  - event log messages ... 8-23
  - menu interface operation ... 8-22
  - operating modes ... 8-2
  - poll interval ... 8-12
  - See also* TimeP and SNTP. ... 8-3
  - selecting ... 8-3
  - unicast mode ... 8-3, 8-10
  - unicast time polling ... 8-20
  - unicast, address priority ... 8-21
  - unicast, deleting addresses ... 8-22
  - unicast, replacing servers ... 8-22
  - viewing ... 8-4, 8-8
- software version ... B-5
- sorting alert log entries ... 4-19
- spanning tree
- 802.1Q standard ... 13-3
  - blocked link ... 13-5
  - blocked port ... 13-4
  - BPDU ... 13-3
  - broadcast storm ... 13-3, 13-7
  - caution, fast-uplink ... 13-28
  - configuring per-port parameters ... 13-14
  - configuring RSTP ... 13-9
  - configuring whole-switch parameters ... 13-12
  - configuring with the menu ... 13-16
  - description of operation ... 13-4
  - enabling from the browser interface ... 13-41
  - enabling in the CLI ... 13-23
  - enabling RSTP ... 13-11
  - enabling STP ... 13-11
  - fast mode ... 13-20, 13-26
  - fast-uplink terminology ... 13-29
  - fast-uplink, configuring ... 13-39
  - fast-uplink, menu ... 13-31
  - fast-uplink, operating notes ... 13-40
  - fast-uplink, troubleshooting ... C-14
  - fast-uplink, viewing status, CLI ... 13-37
  - fast-uplink, viewing status, menu ... 13-35
  - fast-uplink, with port trunks ... 13-40
  - global information ... B-17
  - information screen ... B-17
  - link priority ... 13-6

- loop, network ... 13-3
  - problems related to ... C-14
  - redundant path ... 13-3
  - RSTP edge port parameter ... 13-14
  - RSTP mcheck parameter ... 13-14
  - RSTP path-cost parameter ... 13-14
  - RSTP point-to-point-mac parameter ... 13-14
  - RSTP priority parameter ... 13-14
  - rules, operating, fast-uplink ... 13-30
    - server access failure ... 13-6
  - show tech, copy output ... C-30
  - statistics ... B-17
  - using with port trunking ... 9-15
  - viewing the configuration ... 13-10
  - VLAN effect on ... 11-30
    - with 802.1Q VLANs ... 13-4
  - spanning tree and CDP ... 10-24
- SSH
- troubleshooting ... C-15
- stacking
- benefits ... 14-3, 14-4
  - minimum software version, other HP switches ... 14-9
  - primary ... 14-45
- standard MIB ... 10-3
- starting a console session ... 2-4
- startup-config, viewing
- See also configuration*
- static VLAN, convert to ... 11-33
- statistical sampling ... 10-2
- statistics ... 2-7, B-3
- statistics, clear counters ... 2-12, 5-10
- status and counters
- access from console ... 2-7
- status and counters menu ... B-4
- status overview screen ... 4-6
- STP
- See spanning tree.*
- subnet ... 12-12
- subnet address ... 11-3
- subnet mask ... 7-4, 7-6
- See also IP.*
- support
- changing default URL ... 4-13
  - URL ... 4-12
  - URL Window ... 4-12
- switch console
- See console.*

- switch setup menu ... 2-8
- switch-to-switch download ... A-9
- system configuration screen ... 6-9
- System Name parameter ... 6-10

## T

- tagged VLAN
  - See *VLAN*.
- TCP/IP reference book ... 7-18
- Telnet ... 2-4
  - terminate session, kill command ... 6-8
- Telnet, enable/disable ... 6-4
- Telnet, outbound ... 6-6
- Telnet, problem ... C-5
- terminal access, lose connectivity ... 6-6
- terminal type ... 6-3
- terminate remote session ... 6-8
- TFTP
  - download ... A-4
  - OS download ... A-3
- threshold setting ... 10-4
- thresholds, SNMP ... 10-8
- time format ... C-21
- time protocol
  - selecting ... 8-3
- time server ... 7-3
- time, configure ... 6-13
- TimeP ... 7-3, 7-5
  - assignment methods ... 8-2
  - disabling ... 8-19
  - enabling and disabling ... 8-17
  - poll interval ... 8-19
  - selecting ... 8-3
  - viewing and configuring, menu ... 8-14
  - viewing, CLI ... 8-16
- timesync, disabling ... 8-19
- Time-To-Live ... 7-3, 7-5
- top talker ... 9-32
- TopTools ... 1-6
- TopTools system requirements ... 4-4
- TopTools, main screen ... 1-6
- traffic analysis ... 10-2
- traffic monitoring ... 10-2, 10-4
- traffic, monitoring ... B-23
- traffic, port ... B-9
- transceiver, fiber-optic ... 9-4
- transceiver, speed change ... 9-4

- trap ... 4-24
  - authentication ... 10-8
  - authentication trap ... 10-11
  - CLI access ... 10-8
  - configuring ... 10-10
  - event levels ... 10-10
  - limit ... 10-8
  - receiver ... 10-8
  - SNMP ... 10-3, 10-8
  - Trap Receivers Configuration screen ... 10-8
- troubleshooting
  - approaches ... C-3
  - browsing the configuration file ... C-29
  - console access problems ... C-4
  - diagnosing unusual network activity ... C-6
  - diagnostics tools ... C-24
  - fast-uplink ... C-14
  - OS download ... A-12
  - ping and link tests ... C-24
  - restoring factory default configuration ... C-34
  - spanning tree ... C-14
  - SSH. ... C-15
  - switch won't reboot, shows => prompt ... C-35
  - unusual network activity ... C-6
  - using the event log ... C-21
  - web browser access problems ... C-4
- trunk
  - See *port trunk*.
- trunk group
  - FEC ... 9-26
- TTL ... 7-3, 7-5
- types of alert log entries ... 4-20

## U

- unauthorized access ... 10-11
- Universal Resource Locator
  - See *URL*.
- Unix, Bootp ... 7-12
- unrestricted write access ... 10-4
- unusual network activity ... C-6
- up time ... B-5
- URL ... 4-13
  - browser interface online help location ... 4-13
  - HP Procurve ... 4-13
  - management ... 4-13
  - management server ... 4-12, 4-13
  - support ... 4-12, 4-13

- URL, HP Procurve ... 10-3
- user name, using for browser or console access ... 4-8, 4-10
- using the passwords ... 4-10
- utilization, port ... 4-16

## V

- version, OS ... A-5, A-7, A-10

### VID

- See *VLAN*.

### Viewing

- spanning tree configuration ... 13-10

### virtual stacking

- transmission interval range ... 14-15, 14-16

### VLAN ... 7-4, 11-3, 11-30, C-19, D-1

- 802.1Q ... 13-4

- address ... 10-2

- Bootp ... 7-12

- configuring Bootp ... 7-12

- convert dynamic to static ... 11-33

- dedicated management ... 11-6

- DEFAULT\_VLAN ... 11-6

- deleting ... 11-31

- device not seen ... C-18

- DHCP, primary VLAN ... 11-7

- dynamic ... 11-3, 11-9, 11-10, 11-15

- effect on spanning tree ... 11-30

- event log entries ... C-21

- gateway, IP ... 11-7

- ID ... 3-15

- IGMP configuration ... 12-5

- limit ... 11-10, 11-15

- link blocked ... C-14

- MAC address ... 11-31

- management VLAN, SNMP block ... 10-2

- maximum, GVRP ... 11-46

- monitoring ... B-2

- multiple ... 10-2

- multiple VLANs on port ... 11-24

- notes on using ... 11-9

- number allowed, including dynamic ... 11-13

- OS download ... A-3

- port assignment ... 11-13

- port configuration ... 11-25, C-19

- port monitoring ... 11-31

- port restriction ... 11-31

- port trunk ... 11-31

- primary ... 7-3, 11-7, 14-9, 14-33, 14-45

- primary VLAN ... 11-6

- primary, CLI command ... 11-16, 11-18

- primary, select in menu ... 11-11

- primary, web configure ... 11-21

- primary, with DHCP ... 11-9

- reboot required ... 2-8

- restrictions ... 11-31

- spanning tree operation ... 13-4

- stacking, primary VLAN ... 11-7

- static ... 11-3, 11-7, 11-10, 11-15

- support enable/disable ... 2-8

- switch capacity ... 11-3

- tagged ... 11-4

- tagging ... 11-22, 11-24

- tagging broadcast, multicast, and unicast traffic ... C-18

- unknown VLAN ... 11-40

- untagged ... 11-5, 11-14

- VID ... 11-3, 11-23

- VID, default VLAN ... 11-7

- VLAN already exists, message ... 11-21

### VLAN ID

- See *VLAN*.

- VT-100 terminal ... 6-3

## W

- warranty ... ii

- web agent enabled ... 4-2

- web agent,

- advantages ... 1-5

- web browser access configuration ... 6-3

- web browser enable/disable ... 6-4

- web browser interface

- access parameters ... 4-8

- alert log ... 4-6, 4-19

- alert log details ... 4-21

- alert types ... 4-20

- bandwidth adjustment ... 4-17

- bar graph adjustment ... 4-17

- configuration, support URL ... 4-13

- disable access ... 4-2

- enabling ... 4-4

- enabling RSTP ... 13-18

- error packets ... 4-16

- fault detection policy ... 4-8, 4-23

- fault detection window ... 4-23

- features ... 1-5
- first-time install ... 4-7
- first-time tasks ... 4-7
- help via TopTools ... 4-13
- main screen ... 4-15
- management server URL ... 4-13
- online help ... 4-13
- online help location specifying ... 4-13
- online help, inoperable ... 4-13
- overview ... 4-15
- Overview window ... 4-15
- password lost ... 4-11
- password, setting ... 4-9
- port status ... 4-18
- port utilization ... 4-16
- port utilization and status displays ... 4-16
- screen elements ... 4-15
- security ... 4-2, 4-8
- standalone ... 4-4
- status bar ... 4-22
- status indicators ... 4-22
- status overview screen ... 4-6
- system requirements ... 4-4
- troubleshooting access problems ... C-4
- URL default ... 4-14
- URL, management server ... 4-14
- URL, support ... 4-14
- web browser interface, for configuring
  - IGMP ... 12-10
  - STP ... 13-41
- web site, HP ... 10-3
- world wide web site, HP
  - See HP Procurve.
- write access ... 10-4
- write memory ... 11-47
- write memory, effect on menu interface ... 2-13

## **X**

- Xmodem OS download ... A-6







i n v e n t

Technical information in this document  
is subject to change without notice.

©Copyright Hewlett-Packard Company 2002.  
All right reserved.

Reproduction, adaptation, or translation  
without prior written permission is prohibited  
except as allowed under the copyright laws.

Produced in Singapore  
Edition 2, May 2002

Manual Part Number  
5990-3007

