Chapter 2

Installation

This chapter outlines the physical installation and network connection for the HP 9304M, HP 9308M, and HP 6308M-SX routing switches and the HP 6208M-SX switch.

Unpacking a System

Package Contents

For a list of included parts, please refer to the *Read Me First* document shipped with your HP device.

General Requirements

To manage a switch or routing switch, you need the following items for serial connection to the device:

- A management station, such as a PC running a terminal emulation application.
- A straight-through EIA/TIA DB-9 serial cable (M/F), which is provided with your HP switch or routing switch.

Use the serial connection to perform basic configuration tasks including assigning an IP address and network mask to the system. This information is required for managing the system using the Web management interface or using the CLI through Telnet.



WARNING: Do not use the handles on the power supply units to lift or carry the HP 9304M or HP 9308M routing switch.

Installation Procedures

Summary

Follow the steps listed below to install your routing switch. Details for each of the steps highlighted below are provided in the balance of this chapter.

1. **Preparing the installation site (page 2-4).** Ensure that the physical environment that will host the routing switch has the proper cabling and ventilation.
2. **Chassis devices only – Installing (or Removing) Optional Modules (page 2-4).** There are many optional modules designed for any of the module slots on the HP 9304M or HP 9308M routing switches. Depending on where you will install the routing switch, it may be easier to install the modules first. However, the modules are “hot swappable”, and can be installed or removed after the routing switch is mounted and powered-on.

NOTE: If you are installing a second Redundant Management module, see “Using Redundant Management Modules” on page 4-1 for complete installation, configuration, and management instructions for this module.

3. **Chassis devices only – (Optional) Installing (or Removing) Redundant Power Supplies (page 2-6).** The HP 9304M can hold one or two power supplies. The HP 9308M can hold up to four power supplies. If you have a power supply to install, it may be easier to install it before mounting the routing switch, although the power supplies are “hot swappable”, and can be installed or removed after the routing switch is mounted and powered-on.

CAUTION: Remove the power cord from a power supply before you install it in or remove it from the routing switch. Otherwise, damage to the power supply or the routing switch could result. (The routing switch can be running while a power supply is being installed or removed, *but the power supply itself should not be connected to a power source.*)

4. **Verifying Proper Operation (page 2-9).** Verify that the system and module LEDs are registering the proper LED state after power-on of the system.
5. **Attaching a PC or Terminal (page 2-10).** A terminal or PC serial port connection is all that is required to support configuration on the routing switch.
6. **Assign a Permanent Password (page 2-12).** No default password is assigned to HP devices. For additional access security, assign a password.
7. **Assign Permanent IP Addresses (page 2-13).** Before attaching equipment to the device, assign an interface IP address to the sub-net on which it will be located. Initial IP address assignment is done using the Command Line Interface (CLI) with either a direct serial connection or using Telnet with a direct terminal-to-device LAN connection. The subsequent IP address assignments used with routing switches can be done via Telnet or the Web management interface.
8. **Mounting the Device (page 2-15).** HP switches and routing switches support both desktop and rack-mount installation.
9. **Connecting Power to the Device (page 2-17).** Once the device is physically installed, plug the device into a nearby power source in keeping with regulatory requirements outlined in this manual.
10. **Connecting Network Devices (page 2-18).** Once the device is powered on and IP addresses are assigned, the device is ready to accept network equipment.
11. **Verifying Proper Connections (page 2-20).** Test IP connectivity to other devices by pinging them and tracing routes.
12. **Managing the device (page 2-21).** Continue configuring the device using the CLI or the Web management interface.
13. **Chassis devices only – Swapping Modules (page 2-25).** If you are removing a module and placing a module of another type in its slot, you need to reconfigure the chassis slot for the module.

Installation Precautions

Follow these precautions when installing an HP switch or routing switch:

WARNING: The HP 9304M chassis exceeds 40 lbs. (18 kg), or 47.7 lbs.(21.6 kg) when fully populated with modules and power supplies. Also, the HP 9308M chassis exceeds 55 lbs. (24.9 kg) or 69.1 lbs. (31.3 kg) when fully populated with modules and power supplies. **TWO OR MORE PEOPLE ARE REQUIRED WHEN LIFTING, HANDLING, OR MOUNTING THESE ROUTING SWITCHES.**

WARNING: Do not use the handles on the power supply units to lift or carry the routing switch.

WARNING: The rack or cabinet housing the switch or routing switch should be adequately secured to prevent it from becoming unstable and/or falling over.

WARNING: Devices installed in a rack or cabinet should be mounted as low as possible, with the heaviest device at the bottom and progressively lighter devices installed above.

CAUTION:

- Make sure that the power source circuits are properly grounded, then use the power cord supplied with the device to connect it to the power source.

If the installation requires a different power cord than the one supplied with the device, be sure to use a power cord displaying the mark of the safety agency that defines the regulations for power cords in your country. The mark is your assurance that the power cord can be used safely with the device.

- Ensure that the device does not overload the power circuits, wiring, and over-current protection. To determine the possibility of overloading the supply circuits, add together the ampere ratings of all devices installed on the same circuit as the switch or routing switch. Compare this total with the rating limit for the circuit. The maximum ampere ratings are usually printed on the devices, near their AC power connectors.
 - Do not install the device in an environment where the operating ambient temperature might exceed 40 degrees C (104 degrees F).
 - Make sure the air flow around the front, sides, and back of the device is not restricted.
 - To provide additional safety and proper airflow to the device, make sure that slot cover plates are installed on all chassis slots that do not have either a module or power supply installed.
-

1. Preparing the Installation Site

Cabling Infrastructure

Ensure that the proper cabling is installed in the site. See “Hardware Overview” on page 7-1 for a summary of supported cabling types and their specifications.

Installation Location

Before installing the device, plan its location and orientation relative to other devices and equipment. Allow at least three inches (3") of space at the front of the device for the twisted-pair, fiber-optic and power cabling. Also, a minimum of three inches (3") of space should be allowed between the sides and the back of the device and walls or other obstructions.

2. Installing (or Removing) Optional Modules (Chassis Devices only)

Installing Modules

To install a module in the chassis, do the following:

1. Put on an ESD wrist strap and attach the clip end to a metal surface (e.g. an equipment rack) to act as ground.

WARNING: To avoid risk of shock, do not attach the clip end to the air flow panel of the power supply.

2. Remove the blank face plate from the slot in which the module is to be installed. Place the blank face plate in a safe place for future use.
3. Remove the module from its packaging.
4. Insert the module into the chassis slot and glide the card along the card guide until the card ejectors on the front of the module touch the chassis.

CAUTION: To avoid hardware damage during installation, be careful to properly line up the edges of the module board with the guides built into the module slot on the chassis.

NOTE: Modules for the HP 9308M slide in vertically with the module label (e.g. ProCurve 9300) and port number 1 at the top (Figure 2.3). Modules for the HP 9304M slide in horizontally with the module label (e.g. ProCurve 9300) and port number 1 on the left (Figure 2.4).

5. Push the ejectors toward the center of the module until they are flush with the front panel of the module. The module will be fully seated in the backplane.
6. Tighten the two screws at either end of the module.

CAUTION: If one or more of the slots remains unused, make sure that a slot cover plate is still attached over each unused slot for safe operation and proper system cooling.

NOTE: If installing a module into a slot *previously occupied by a different type of module*, you must use the CLI to configure the new module (with the CLI command, **module** <slot-num> <module-type>) and then use the **write memory** command to save the configuration and the **reload** command to reset the routing switch. See “Swapping Modules (Chassis Devices only)” on page 2-25. If the slot has never contained a module or you are swapping in exactly the same type of module, you do not need to enter these commands.

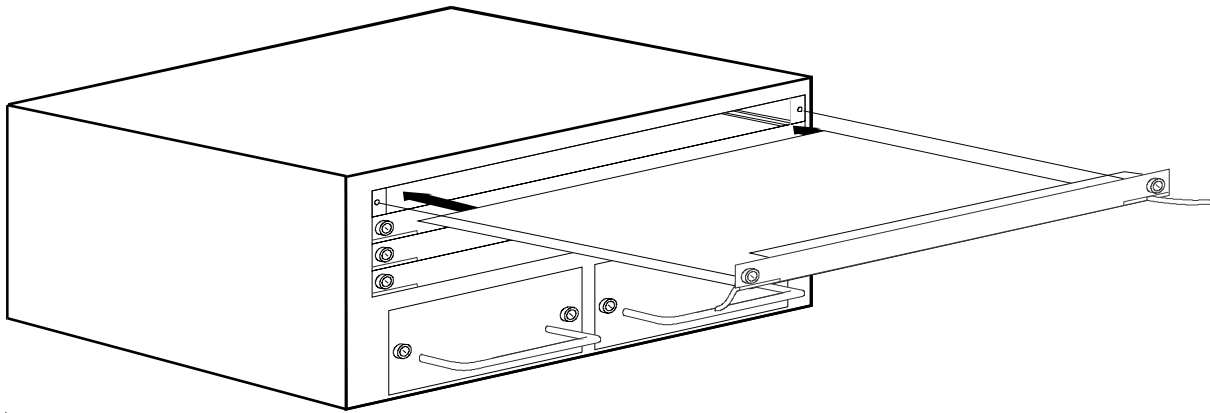

Figure 2.1 Installing a Module

Removing Modules

To remove a module from the chassis, do the following:

1. Put on an ESD wrist strap and attach the clip end to a metal surface (e.g. an equipment rack) to act as ground.

WARNING: To avoid risk of shock, do not attach the clip end to the air flow panel of the power supply.

2. Loosen the two screws on the module.
3. Pull the card ejectors towards you, and away from the module front panel. The card will unseat from the backplane.
4. Pull the module out of the chassis and place in an anti-static bag for storage.
5. Cover the slot with the blank face plate that shipped with the chassis.

CAUTION: If you remove a module and do not replace it, cover the slot opening with one of the blank plates you received with the routing switch to provide additional safety and airflow for the system.

NOTE: Modules can be installed and removed when the unit is powered on (hot swap). There is no need to power the system down. You do not need to change the slot's configuration unless you plan to insert a different type of module. See "Swapping Modules (Chassis Devices only)" on page 2-25.

3. Installing (or Removing) Redundant Power Supplies (Chassis Devices Only)

Determining Power Supply Status

If you are replacing a power supply that has failed and you are not sure which supply has failed, enter the following command at any CLI command prompt:

```
show chassis
```

This command displays status information for the fans and the power supplies. The power supplies are numbered in the display. The power supply numbers correspond to the following positions. These positions assume you are facing the front of the **Chassis device**, not the rear.

Table 2.1: Power Supply Positions in Chassis Devices

Product	Power Supply 1 Position	Power Supply 2 Position	Power Supply 3 Position	Power Supply 4 Position
HP 9304M	left side	right side	n/a	n/a
HP 9308M	bottom	second from bottom	second from top	top

Installing Power Supplies

To install a power supply in the chassis, do the following:

CAUTION: Power supplies are hot swappable but they should be disconnected from AC power before being installed or removed. That is, the routing switch can be running while a power supply is being installed or removed, but the power supply itself *should not be connected* to a power source. Otherwise, damage to the power supply or the routing switch could result.

1. Use a screwdriver to remove the blank power supply face plate. This will expose the empty power supply slot.
2. Remove the power supply from its packaging.
3. Holding the bar on the front panel of the power supply, insert the power supply into the empty power supply slot using the module guides provided on either side of the compartment.

CAUTION: Carefully follow the mechanical guides on each side of the power supply slot and make sure the power supply is properly inserted in the guides. Never insert the power supply upside down.

4. Continue to slide the power supply towards the back of the chassis until the two metal rods and the connector make contact with the back connector. Then push the power supply until the front panel of the power supply is flush with the rest of the chassis.
5. Use a screwdriver to tighten the two screws on either side of the power supply.
6. Connect the power cord to the front of the power supply.
7. Connect the power plug into an outlet.

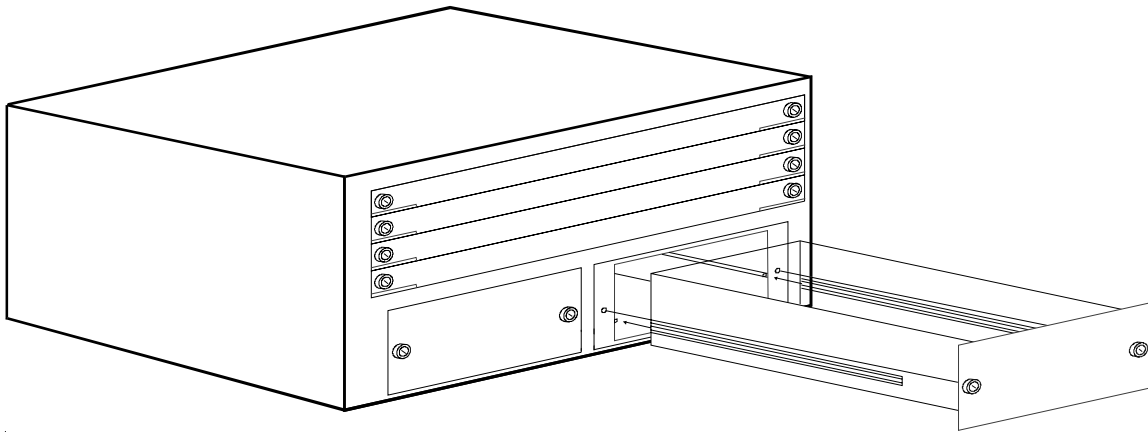

Figure 2.2 Installing a Power Supply

Removing Power Supplies

To remove a power supply module from the chassis, do the following:

CAUTION: Power supplies are hot swappable but they should be disconnected from AC power before being installed or removed. That is, the routing switch can be running while a power supply is being installed or removed, but the power supply itself *should not be connected* to a power source. Otherwise, damage to the power supply or the routing switch could result.

1. Unplug the power supply AC power cord from the outlet.
2. Disconnect the power cord from the power supply.
3. Use a screwdriver to loosen the screws on either side of the power supply.
4. Holding the bar on the front panel of the power supply, pull outward, disconnecting the power supply from the backplane.
5. Continue to pull the power supply until it is removed from the chassis.
6. Place the power supply in an anti-static bag for storage.
7. Cover the power supply slot with the blank power supply cover that came with the device.
8. Use a screwdriver to tighten the screws.

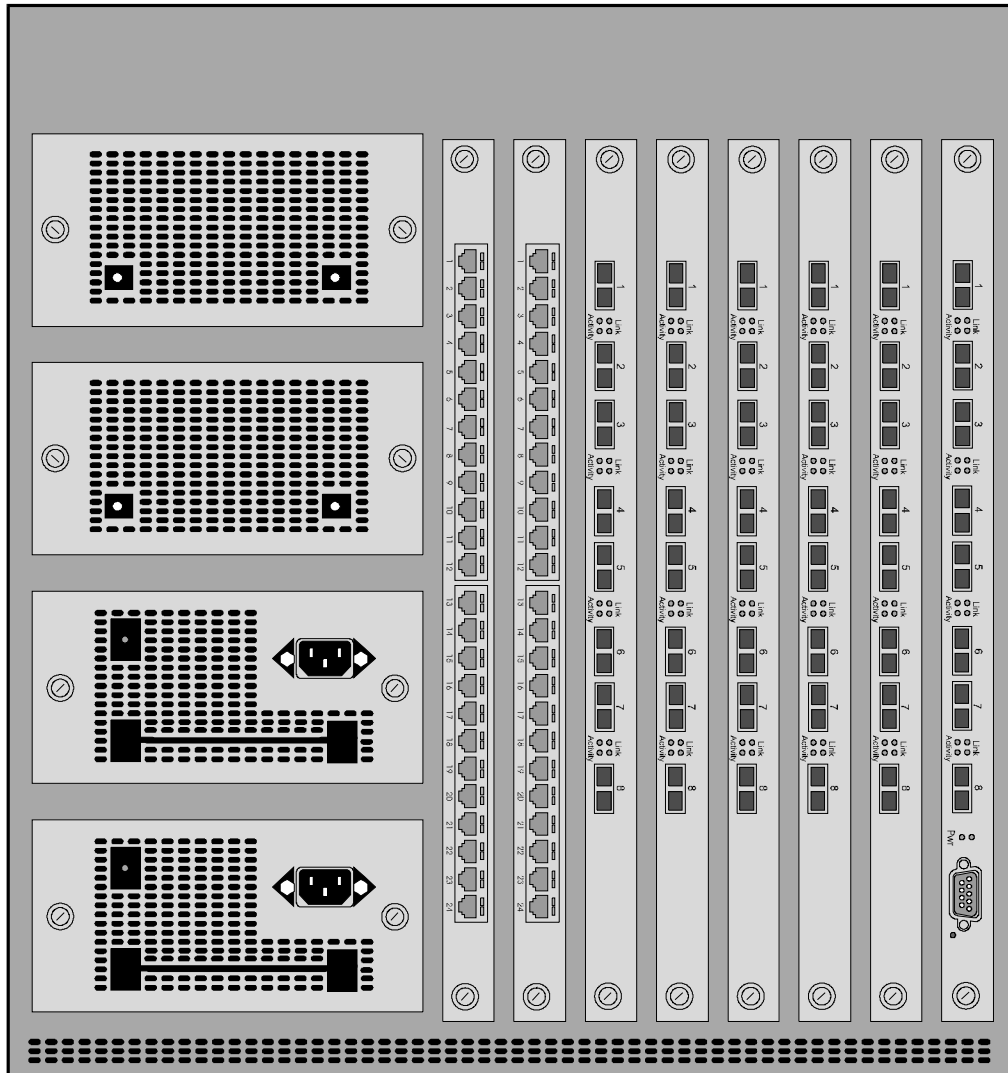

Figure 2.3 Example of the front panel of an HP 9308M routing switch

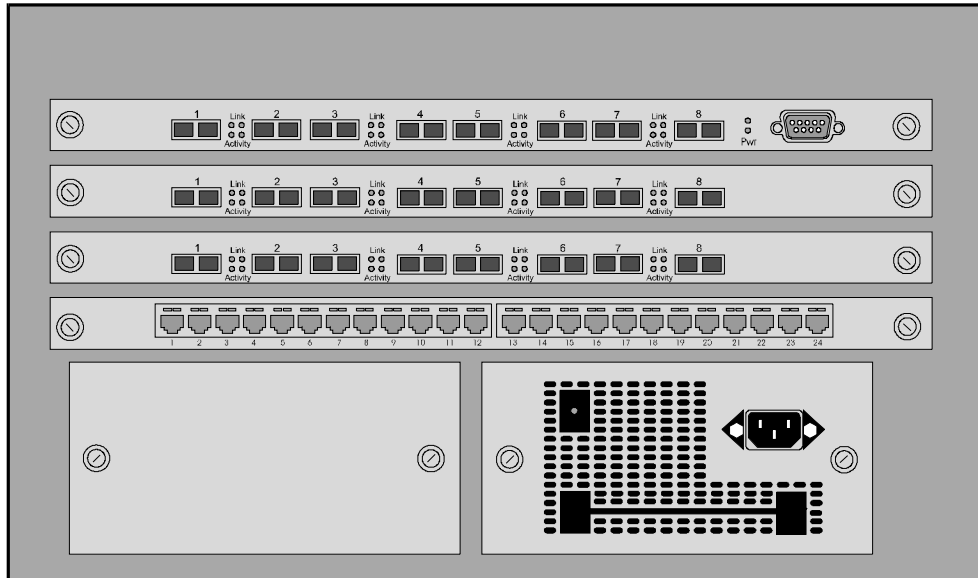

Figure 2.4 Example of the front panel of an HP 9304M routing switch

4. Verifying Proper Operation

After you have installed any modules or redundant power supplies, but before mounting the routing switch in its network location, you should first verify that it is working properly by plugging it into a power source and verifying that it passes its self test.

NOTE: Chassis devices only – If your device has more than one power supply installed, repeat this procedure for each power supply.

1. Connect the power cord supplied with the device to the power connector found on the power supply on the front of the device.
2. Insert the other end into a properly grounded electrical outlet.

NOTE: The devices do not have power switches. They are powered on when the power cord is connected to the device and to a power source.

If your installation requires a different power cord than that supplied with the device, be sure to obtain a power cord displaying the mark of the safety agency that defines the regulations for power cords in your country. The mark is your assurance that the power cord can be used safely with the device.

3. Verify proper operation by observing the LEDs:
 - Chassis devices – Make sure the LED on each power supply is a solid green. Also make sure that some of the port LEDs on each module momentarily light up. The LEDs indicate that the device is performing diagnostics. After the diagnostics are complete, the LEDs will be dark except for the ones that are attached by cables to other devices. If the links on these cables are good and the connected device is powered on, the link LEDs will light.

NOTE: If all of the LEDs on a module do not light up during the diagnostics, this does not indicate an error. Only some of the LEDs are lighted during the diagnostics.

- Fixed-port devices – All the port LEDs should flash momentarily, usually in sequence, while the device performs diagnostics. After the diagnostics are complete, the LEDs will be dark except for the ones that are attached by cables to other devices. If the links on these cables are good and the connected device is powered on, the link LEDs will light.

For more details on specific LED conditions after system start-up, see “LEDs” on page 7-9.

5. Attaching a PC or Terminal

To assign an IP address, you must have access to the **Command Line Interface (CLI)**. The CLI is a text-based interface that can be accessed through a direct serial connection to the device and through Telnet connections. The CLI is described in detail in the *Command Line Interface Reference*.

You need to assign a permanent IP address using the CLI. You can access the CLI by attaching a serial cable to the Console port. After you assign an IP address, you can access the system through Telnet or the Web management interface.

Attaching a PC or Terminal Using a Serial Port

To attach a management station using the serial port:

1. Connect a PC or terminal to the serial port of the system via the (serial) console cable. The serial port is a male DB-9 connector. Generally, a PC port will require a cable with a female DB-9 connector. Terminal connections will vary, requiring either a DB-9 or DB-25 connector, male or female.

A console cable is provided with your switch or routing switch. Cable pin-outs and signalling for the serial cable are shown in Figure 2.5 and Figure 2.6.

2. If you are using a PC for a terminal, run a terminal emulation program on the PC.
3. Set the terminal or PC terminal emulation program to the parameters shown below:
 - Baud: 9600 bps
 - Data bits: 8
 - Parity: None
 - Stop bits: 1
 - Flow control: None

Attaching a PC or Terminal Using a Direct LAN Connection

To attach a management station using a direct LAN connection:

NOTE: Use this procedure if you are unable to make the serial connection described above.

1. Directly connect the LAN port on a Telnet-capable terminal device such as a laptop or desktop PC to one of the following:
 - In a Chassis device, port 1 in slot 1
 - In a Fixed-port device, port 1
2. Configure the terminal device with an IP address and subnet mask that assigns the terminal to the same subnet as the switch or routing switch's IP address for port 1, slot 1 (Chassis device) or port 1 (Fixed-port devices).
3. From the DOS prompt, enter **telnet** <ip-addr> to access the switch or routing switch CLI, where <ip-addr> is the IP address for the switch or routing switch port.

When you establish the serial connection to the device, press Enter to display the CLI prompt for your switch or routing switch. For example:

```
HP9304>
```

```
HP9308>
```

```
HP6308>
```

```
HP6208>
```

If you see one of these prompts, you are now connected to the system and can proceed to “Assigning a Permanent Password” on page 2-12.

NOTE: For simplicity, CLI examples for both the HP 9304M or HP 9308M show the command prompt HP9300. This command prompt represents both the HP 9304M or HP 9308M unless otherwise noted. Command prompts that are specific to the HP 6208M-SX or HP 6308M-SX show HP6208 or HP6308.

You can customize the prompt by changing the system name. See “Entering System Administration Information” on page 8-4.

If you do not see one of these prompts:

1. Make sure the cable is securely connected to your PC and to the HP device.
2. Check the settings in your terminal emulation program. In addition to the session settings listed above, make sure the terminal emulation session is running on the same serial port you attached to the HP device.

The EIA/TIA 232 serial communication port serves as a connection point for management by a PC or SNMP workstation. HP switches and routing switches come with a standard male DB-9 connector, shown in Figure 2.5.

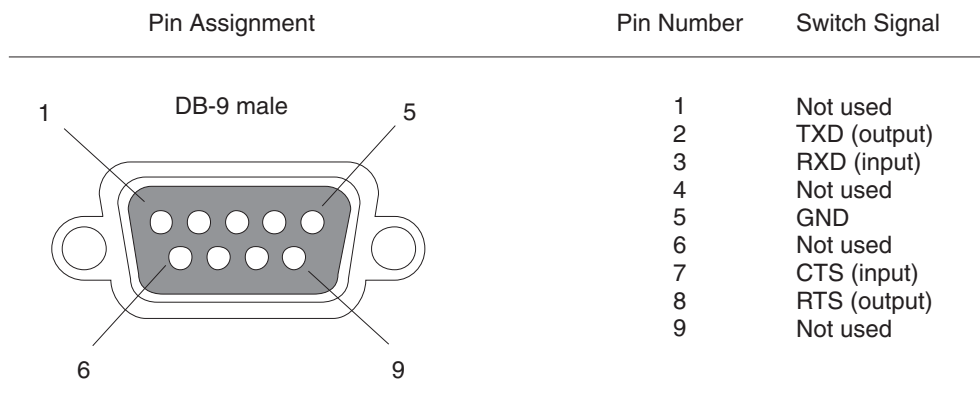

Figure 2.5 Serial port pin and signalling details

Most PC serial ports also require a cable with a female DB-9 connector. Terminal connections will vary, requiring either a DB-9 or DB-25 connector, male or female. Serial cable options between an HP switch or routing switch and a PC terminal are shown in Figure 2.6.

NOTE: As indicated in Figure 2.5 and Figure 2.6, some of the wires should not be connected. If you do connect the wires that are labeled “Not Used” or “Not Connected”, you might get unexpected results with some terminals.

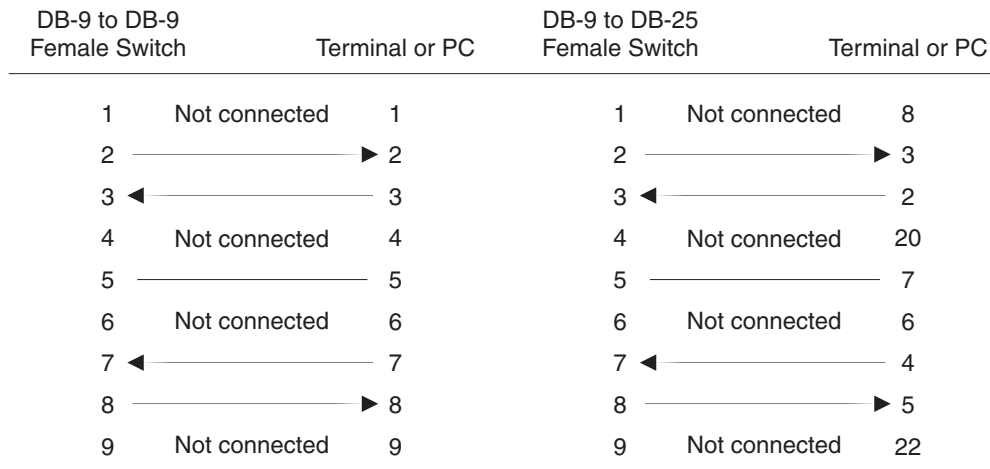

Figure 2.6 Serial port signal directions

6. Assigning a Permanent Password

You must use the CLI to assign a password. A password cannot be assigned through the Web management interface.

The CLI contains the following access levels:

- **User EXEC level** – The level you enter when you first start a CLI session. At this level, you can view some system information but you cannot configure system or port parameters.
- **Privileged EXEC level** – This level is also called the Enable level and can be secured by a password. You can perform tasks such as manage files on the flash module, save the system configuration to flash, and clear caches at this level.
- **CONFIG level** – The configuration level. This level lets you configure the system’s IP address and configure switching and routing features. To access the CONFIG mode, you must already be logged into the Privileged level of the EXEC mode.

By default, there are no CLI passwords. To secure CLI access, you must assign passwords.

NOTE: You must use the CLI to assign a password. You cannot assign a password using the Web management interface or an SNMP network management application.

You can set the following levels of Enable passwords:

- Super User – Allows complete read-and-write access to the system. This is generally for system administrators and is the only password level that allows you to configure passwords. *You must set a super user password before you can set other types of passwords.*
- Port Configuration – Allows read-and-write access for specific ports but not for global (system-wide) parameters.
- Read Only – Allows access to the Privileged EXEC mode and CONFIG mode but only with read access.

How To Assign a Password

When you first connect to the CLI, you are at the User EXEC level of the CLI. This is the first level of the CLI. The next level is the Privileged EXEC level. You need to get to the global CONFIG level of the CONFIG command structure to assign a permanent password.

To reach the global CONFIG level and assign passwords, use the following steps:

1. At the opening prompt, enter the following command to go from the User EXEC level to the Privileged EXEC level:

```
HP9300> enable
```

2. Access the configuration level of the CLI by entering the following command:

```
HP9300# configure terminal          Privileged EXEC Level
```

```
HP9300 (config)#                  Global CONFIG Level
```

3. To set the super-user password:

```
HP9300 (config)# enable super-user-password <string>
```

NOTE: You must set a super-user password before you can set other types of passwords.

4. To set the port-configuration and read-only passwords:

```
HP9300 (config)# enable read-only-password <string>
```

```
HP9300 (config)# enable port-config-password <string>
```

How to Recover From a Lost Password

Recovery from a lost password requires direct access to the serial port and a system reset of the device.

NOTE: You can perform this procedure only from the CLI.

To recover from a lost password:

1. Start a CLI session over the serial interface to the device.
2. Reboot the device.
3. At the initial boot prompt at system start-up enter **b** to initiate boot monitor mode.
4. Enter **no password** at the prompt. This command cannot be abbreviated. This command will cause the device to bypass the system password check.
5. Enter **boot system flash primary**.
6. After the console prompt reappears, assign a new password.

7. Assign a Permanent IP Address

Before you can manage the switch or routing switch over your network, you must assign at least one IP address to the device. (For more information on IP addressing, see the “Configuring IP and IP/RIP” chapter in the *Advanced Configuration and Management Guide* included on the CD-ROM shipped with your device.)

Routing Switches

Before attaching an HP routing switch to your network, you must assign an interface IP address to the sub-net on which the routing switch will be located. For subsequent addresses, you also can use the CLI through Telnet or use the Web management interface.

Using a serial connection is the recommended method for assigning the first IP address on a routing switch. (You also can use Telnet with a direct, terminal-to-device LAN connection if necessary—see “Attaching a PC or Terminal Using a Direct LAN Connection” on page 2-10.)

On the HP 9304M or HP 9308M, you can configure up to 24 IP interfaces on each port, virtual interface, and loopback interface. On the HP 6308M-SX routing switch, you can increase this amount to up to 64 IP sub-net addresses per port by increasing the size of the subnet-per-interface table. See “Displaying and Modifying System Parameter Default Settings” on page 8-58.

The following procedure shows how to add an IP address and mask to a routing switch port.

1. At the opening CLI prompt, enter **enable**.

```
HP9300> enable
```

2. Enter the following command at the Privileged EXEC level prompt (for example, HP9300#), then press Enter. This command erases the factory test configuration if still present:

```
HP9300# erase startup-config
```

WARNING: Use this step only for new systems. If you enter this command on a system you have already configured, the command erases the configuration. If you accidentally do erase the configuration on a configured system, enter the **write memory** command to save the running configuration to the startup-config file.

3. Access the configuration level of the CLI by entering the following command:

```
HP9300# configure terminal          Privileged EXEC Level
HP9300(config)#                   Global CONFIG Level
```

4. Set the IP and mask addresses.

```
HP9300(config)# int e 1/5
HP9300(config-if-1/5)# ip address 192.22.3.44 255.255.255.0
```

NOTE: You can use the syntax, **ip address** <ip-addr> /<mask-bits> if you know the sub-net mask length. In the above example, you could enter **ip address 192.22.3.44/24**.

Syntax: enable [<password>]

Syntax: configure terminal

Syntax: [no] ip address <ip-addr> <ip-mask> [secondary]

or

Syntax: [no] ip address <ip-addr>/<mask-bits> [secondary]

Use the **secondary** parameter if you have already configured an IP address within the same sub-net on the interface.

Switches

Using a serial connection is the recommended method for assigning the IP address on a switch. (You also can use Telnet with a direct, terminal-to-device LAN connection if necessary—see “Attaching a PC or Terminal Using a Direct LAN Connection” on page 2-10.)

To assign an IP Address to the HP 6208M-SX switch:

1. At the opening CLI prompt, enter **enable**.

```
HP6208> enable [<password>]
```

2. Enter the following command at the Privileged EXEC level prompt (for example, HP6208#), then press Enter. This command erases the factory test configuration if still present:

```
HP6208# erase startup-config
```

WARNING: Use this step only for new systems. If you enter this command on a system you have already configured, the command erases the configuration. If you accidentally do erase the configuration on a configured system, enter the **write memory** command to save the running configuration to the startup-config file.

3. Access the configuration level of the CLI by entering the following command:

```
HP6208# configure terminal
```

 Privileged EXEC Level

```
HP6208 (config)#
```

 Global CONFIG Level

4. Set the IP and mask addresses for the switch.

```
HP6208 (config)# ip address 192.22.3.44 255.255.255.0
```

5. Set a default gateway address for the switch.

```
HP6208 (config)# ip default-gateway 192.22.3.1
```

NOTE: You do not need to assign a default gateway address for single sub-net networks.

Syntax: enable [<password>]

Syntax: configure terminal

Syntax: [no] ip address <ip-addr> <ip-mask>

or

Syntax: [no] ip address <ip-addr>/<mask-bits>

Syntax: ip default-gateway <ip-addr>

8. Mounting the Device

The HP switch and routing switches can be installed on a desktop or in a rack.

WARNING: The HP 9304M chassis exceeds 40 lbs. (18 kg), or 47.7 lbs.(21.6 kg) when fully populated with modules and power supplies. Also, the HP 9308M chassis exceeds 55 lbs. (24.9 kg) or 69.1 lbs. (31.3 kg) when fully populated with modules and power supplies. TWO OR MORE PEOPLE ARE REQUIRED WHEN LIFTING, HANDLING, OR MOUNTING THESE ROUTING SWITCHES.

WARNING: Do not use the handles on the power supply units to lift or carry a routing switch.

WARNING: Make sure the rack or cabinet housing the routing switch is adequately secured to prevent it from becoming unstable and/or falling over.

WARNING: Mount the devices you install in a rack or cabinet as low as possible, with the heaviest device at the bottom and progressively lighter devices installed above. HP recommends that the HP 9304M or HP 9308M be installed at the bottom of the rack or installed with a shelf and mounting brackets.

Desktop Installation

1. Set the device on a flat desktop, table, or shelf. Use a sturdy surface in an uncluttered area. You may want to secure the networking cables and power cord to the table legs or other part of the surface structure to help prevent people from tripping over them.
2. Make sure that adequate ventilation is provided for the system—a minimum of three inches (3") clearance is recommended on all sides.

NOTE: Make sure the air flow is unrestricted around the front, sides, and back of the switch or routing switch.

3. Proceed to “Connecting Power to the Device” on page 2-17.

Rack Mount Installation – Chassis Devices

NOTE: You need a #2 Phillips-head screwdriver for installation.

1. Remove the rack mount kit from the shipping carton. There will be two L-shaped mounting brackets and mounting screws.
2. Attach the mounting brackets to the sides of the routing switch as illustrated in Figure 2.7.
3. Attach the system in the rack as illustrated in Figure 2.7.
4. Proceed to “Connecting Power to the Device” on page 2-17.

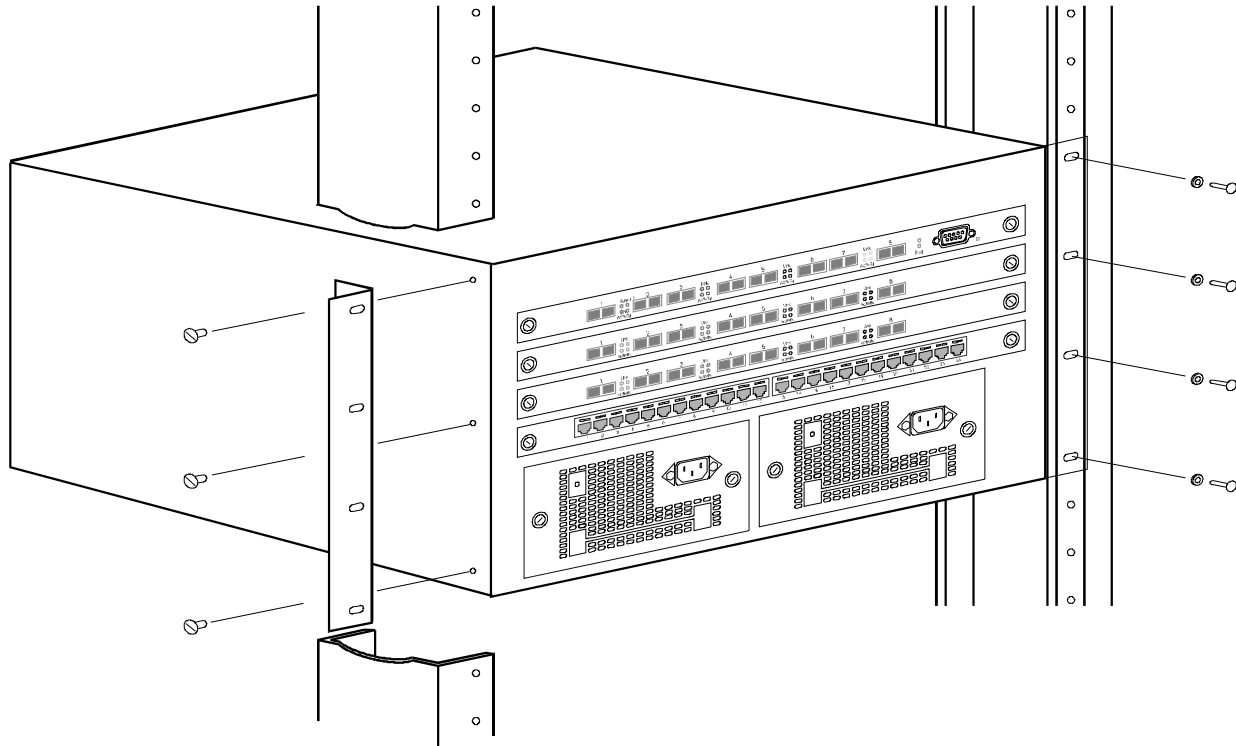

Figure 2.7 Installing an HP 9304M routing switch in a rack mount

Rack Mount Installation – HP 6208M-SX or HP 6308M-SX

NOTE: You need a #2 Phillips-head screwdriver for installation.

1. Remove the rack mount kit from the shipping carton. The kit contains two L-shaped mounting brackets and mounting screws.
2. Attach the mounting brackets to the sides of the device as illustrated in Step 2 of Figure 2.8.
3. Attach the device in the rack as illustrated in Step 3 of Figure 2.8.
4. Proceed to “Connecting Power to the Device” below.

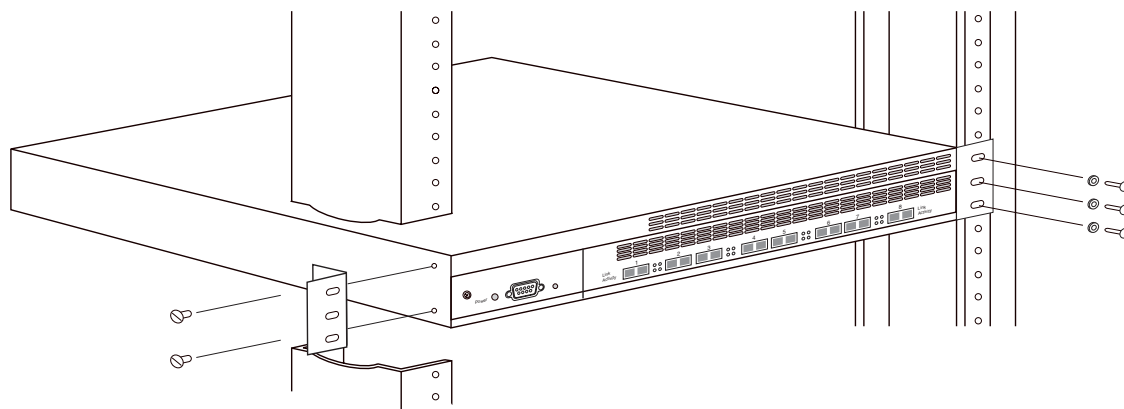

Figure 2.8 Installing an HP 6208M-SX or HP 6308M-SX in a rack mount

9. Connecting Power to the Device

With physical installation of the switch or routing switch complete, it is now time to power up the system and connect the network devices.

CAUTION: There is no separate on/off power switch for the device. The device is powered on when the power cord is connected to a power supply and to a power source. To turn the system off, simply unplug the power cord(s).

CAUTION: The power sockets should be installed near the device and should be easily accessible.

CAUTION: If your installation requires a different power cord than the one supplied with the device, be sure to use a power cord displaying the mark of the safety agency that defines the regulations for power cords in your country. The mark is your assurance that the power cord can be used safely with the system.

NOTE: When you power on a Chassis device that requires multiple power supplies, make sure you apply power to all the supplies (or at least the minimum number of supplies required for your configuration) at the same time. Otherwise, the device either will not boot at all, or will boot and then repeatedly display a warning message stating that you need to add more power supplies.

1. For a Chassis device, ensure that all modules and power supplies are properly inserted, and that no module slots or power supply slots are uncovered.
-

WARNING: Electrical shock hazard. Never allow any part of your body to be inside the chassis when the device is connected to a power source or to the network.

2. Remove the power cord from the shipping package.
 3. Attach the AC power cord to the AC connector on the front panel of Chassis device or the rear panel of Fixed-port devices. If more than one power supply is installed, attach a power cord for each power supply.
 4. Insert the power cord plug(s) into the appropriate outlet(s).
-

10. Connecting Network Devices

HP switches and routing switches can support connections to other vendors' routers, switches, and hubs as well as to other HP switches, routing switches, and hubs.

Connectors

- 10/100BaseTX ports come with RJ45 jacks for standard unshielded twisted pair (UTP/Category 5) cable connections.
- 100BaseFX ports come equipped with MT-RJ connectors.
- 1000BaseSX ports come equipped with SC connectors.
- 1000BaseLX ports come equipped with SC connectors.

Pin Assignment	10BaseT		100BaseTX	
	Pin Number	MDI-X ports	Pin Number	MDI-X ports
	1	RD+	1	RD+
	2	RD-	2	RD-
	3	TD	3	TD
	4	Not used	4	CMT
	5	Not used	5	CMT
	6	TD-	6	TD-
	7	Not used	7	CMT
	8	Not used	8	CMT

Figure 2.9 Pin assignment and signalling for 10BaseTX and 100BaseTX ports

Cable Length

Table 2.1 Cable length summary table

	Fiber Type	Core Diameter (microns)	Modal Bandwidth (MHz*km)	Minimum Range (meters)
1000Base-SX	MMF	62.5	160	2 – 200 ^a
	MMF	62.5	200	2 – 275 ^b
	MMF	50	400	2 – 500
	MMF	50	500	2 – 550 ^c
1000Base-LX	MMF	62.5	500	2 – 550
	MMF	50	400	2 – 550
	MMF	50	500	2 – 550
	SMF	9	n/a	2 – 5000

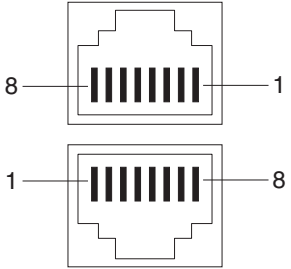
a. The TIA 568 building wiring standard specifies 160/500 MHz*km MMF (Multimode Fiber).

b. The international ISO/IEC 11801 building wiring standard specifies 200/500 MHz*km MMF.

c. The ANSI Fibre Channel specification specifies 500/500 MHz*km 50 micron MMF and 500/500 MHz*km fiber has been proposed for addition to ISO/IEC 11801.

- 100BaseTX: Cable length should not exceed 100 meters in keeping with the IEEE 802.3 standard.
- 100BaseFX: Cable length should not exceed 2 kilometers.
- 1000BaseSX: Cable length should not exceed 550 meters when operating with multi-mode cabling.
- 1000BaseLX:
 - Cable length of 2 – 440 meters is supported on 62.5 μm multi-mode fiber (MMF) cabling.
 - Cable length of 2 – 550 meters is supported on 50 μm multi-mode fiber (MMF) cabling.
 - Cable length of 2 – 5000 meters is supported on 9 μm single-mode fiber (SMF) cabling.

NOTE: Cable installation and network configuration will affect overall transmission capability. The numbers provided above represent the accepted recommendations of the various standards. For network-specific recommendations, consult your local HP reseller or system engineer.

Connecting to Other Routers, Switches, Ethernet or Fast Ethernet Hubs

For UTP connections to Ethernet or Fast Ethernet hubs, a 10/100 Mbps switch or another HP switch or routing switch, a crossover cable is required (Figure 2.10). If the hub is equipped with an uplink port, it will require a straight-through cable instead of a crossover cable.

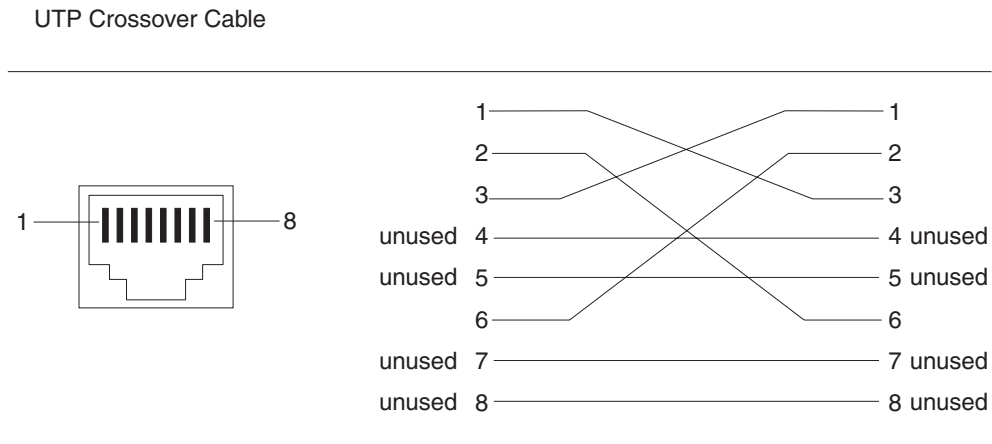

Figure 2.10 UTP crossover cable

Connecting to Workstations, Servers or Routers

Straight-through UTP cabling is required for direct UTP attachment to workstations, servers, or routers via network interface cards (NICs).

Fiber cabling with SC connectors is required for direct attachment to Gigabit NICs or switches and routers.

Troubleshooting Network Connections

- For the indicated port, verify that both ends of the cabling, at the switch or routing switch and the connected device, are snug.
- Verify the connected device and the switch or routing switch are both powered on and operating correctly.
- Verify that you have used the correct cable type for the connection:
 - For twisted-pair connections to an end node, use straight-through cabling.
 - For fiber-optic connections, verify that the transmit port on the switch or routing switch is connected to the receive port on the connected device, and that the receive port on routing switch is connected to the transmit port on the connected device.
- Verify that the port has not been disabled through a configuration change. You can use the CLI or if you have configured an IP address on the routing switch, you can use the Web management interface.
- If the other procedures don't resolve the problem, try using a different port or a different cable.

11. Verifying Proper Connections

After you install the network cables, you can test network connectivity to other devices by pinging those devices. You also can perform trace routes.

Pinging an IP Address

To verify that an HP device can reach another device through the network, enter a command such as the following at any level of the CLI on the HP device:

```
HP9300> ping 192.33.4.7
```

Syntax: ping <ip-addr> | <hostname> [count <num>] [timeout <msec>] [ttl <num>] [size <byte>] [no-fragment] [quiet] [verify] [data <1 – 4 byte hex>]

See the *Command Line Interface Reference* for information about its parameters.

NOTE: If you address the ping to the IP broadcast address, the device lists the lists the first four responses to the ping.

Tracing a Route

To determine the path through which an HP device can reach another device, enter a command such as the following at any level of the CLI on the HP device:

```
HP9300> traceroute 192.33.4.7
```

Syntax: traceroute <host-ip-addr> [maxttl <value>] [minttl <value>] [no-name] [timeout <value>]

The CLI displays trace route information for each hop as soon as the information is received. Traceroute requests display all responses to a given TTL. In addition, if there are multiple equal-cost routes to the destination, the HP device displays up to three responses by default. See the *Command Line Interface Reference* for information about the command syntax.

12. Managing the Device

You can manage an HP device using the following applications:

- Command Line Interface (CLI) – a text-based interface accessible through a direct serial connection or a Telnet session.
- Web management interface – A GUI-based management interface accessible through an HTTP (web browser) connection.
- SNMP network management application – An application such as HP TopTools for Switches & Hubs or HP OpenView.

Logging on Through the CLI

Once an IP address is assigned to the HP switch or to an interface on the HP routing switch, you can access the CLI either through the direct serial connection to the device or through a local or remote Telnet session.

You can initiate a local Telnet or SNMP connection by attaching a straight-through RJ-45 cable to a port and specifying the assigned management station IP address.

The commands in the CLI are organized into the following levels:

- User EXEC level – Lets you display information and perform basic tasks such as pings and traceroutes.
- Privileged EXEC level – Lets you use the same commands as those at the User EXEC level plus configuration commands that do not require saving the changes to the system-config file.
- CONFIG level – Lets you make configuration changes to the device. To save the changes across reboots, you need to save them to the system-config file. The CONFIG level contains sub-levels for individual ports, for VLANs, for routing protocols, and other configuration areas.

NOTE: By default, any user who can open a serial or Telnet connection to the HP device can access all these CLI levels. To secure access, you can configure Enable passwords or local user accounts, and you can configure the device to use a RADIUS or TACACS/TACACS+ server for authentication. See “Securing Access” on page 3-1.

On-Line Help

To display a list of available commands or command options, enter “?” or press Tab. If you have not entered part of a command at the command prompt, all the commands supported at the current CLI level are listed. If you enter part of a command, then enter “?” or press Tab, the CLI lists the options you can enter at this point in the command string.

Command Completion

The CLI supports command completion, so you do not need to enter the entire name of a command or option. As long as you enter enough characters of the command or option name to avoid ambiguity with other commands or options, the CLI understands what you are typing.

Scroll Control

By default, the CLI uses a page mode to paginate displays that are longer than the number of rows in your terminal emulation window. For example, if you display a list of all the commands at the global CONFIG level but your terminal emulation window does not have enough rows to display them all at once, the page mode stops the display and lists your choices for continuing the display.

Here is an example:

```
aaa
all-client
appletalk
arp
boot

some lines omitted for brevity..

ipx
lock-address
logging
mac
--More--, next page: Space, next line: Return key, quit: Control-c
```

The software provides the following scrolling options:

- Press the Space bar to display the next page (one screen at time).
- Press the Return or Enter key to display the next line (one line at a time).
- Press CTRL + C to cancel the display.

Line Editing Commands

The CLI supports the following line editing commands. To enter a line-editing command, use the CTRL-key combination for the command by pressing and holding the CTRL key, then pressing the letter associated with the command.

Table 2.2: CLI Line-Editing Commands

Ctrl-Key Combination	Description
Ctrl-A	Moves to the first character on the command line.
Ctrl-B	Moves the cursor back one character.
Ctrl-C	Escapes and terminates command prompts and ongoing tasks (such as lengthy displays), and displays a fresh command prompt.
Ctrl-D	Deletes the character at the cursor.
Ctrl-E	Moves to the end of the current command line.
Ctrl-F	Moves the cursor forward one character.
Ctrl-K	Deletes all characters from the cursor to the end of the command line.
Ctrl-L; Ctrl-R	Repeats the current command line on a new line.
Ctrl-N	Enters the next command line in the history buffer.
Ctrl-P	Enters the previous command line in the history buffer.

Table 2.2: CLI Line-Editing Commands (Continued)

Ctrl-Key Combination	Description
Ctrl-U; Ctrl-X	Deletes all characters from the cursor to the beginning of the command line.
Ctrl-W	Deletes the last word you typed.
Ctrl-Z	Exits to the CLI level above.

For a complete list of CLI commands and syntax information for each command, see the *Command Line Interface Reference*.

Logging On Through the Web Management Interface

To use the Web management interface, open a web browser and enter the IP address of the HP device in the Location or Address field. The web browser contacts the HP device and displays a login dialog, as shown in Figure 2.11.

NOTE: If you are unable to connect with the switch or routing switch through a Web browser due to a proxy problem, it may be necessary to set your Web browser to direct Internet access instead of using a proxy. For information on how to change a proxy setting, refer to the online help provided with your Web browser.

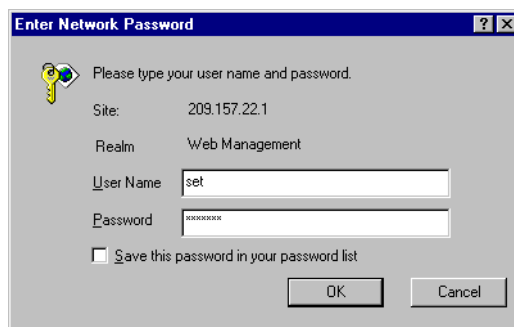

Figure 2.11 Web management interface login dialog

By default, you can use the user name “get” and the default read-only password “public” for read-only access. However, for read-write access, you must enter “set” for the user name, and enter a read-write community string that you have configured on the device for the password. There is no default read-write community string. You must add one. See “Configuring the SNMP Community Strings” on page 3-5.

As an alternative to using the SNMP community strings to log in, you can configure the device to secure Web management access using local user accounts, a RADIUS authentication server, or a TACACS/TACACS+ server. See “Securing Access” on page 3-1.

Using the Web Management Interface

When you log into a device, the System configuration panel is displayed. This panel allows you to enable or disable major system features. You can return to this panel from any other panel by selecting the [Home](#) link.

The [Site Map](#) link gives you a view of all available options on a single screen.

The left pane of the Web management interface window contains a “tree view,” similar to the one found in Windows Explorer. Configuration options are grouped into folders in the tree view. These folders, when expanded, reveal additional options. To expand a folder, click on the plus sign to the left of the folder icon.

You can configure the appearance of the Web management interface by using one of the following methods.

USING THE CLI

Using the CLI, you can modify the appearance of the Web management interface with the **web-management** command.

To cause the Web management interface to display the List view by default:

```
HP9300(config)# web-management list-menu
```

To disable the front panel frame:

```
HP9300(config)# no web-management front-panel
```

When you save the configuration with the **write memory** command, the changes will take place the next time you start the Web management interface, or if you are currently running the Web management interface, the changes will take place when you click the Refresh button on your browser.

USING THE WEB MANAGEMENT INTERFACE

1. Click on the plus sign next to Configure in the tree view to expand the list of configuration options.
2. Click on the plus sign next to System in the tree view to expand the list of system configuration links.
3. Click on the plus sign next to Management in the tree view to expand the list of system management links.
4. Click on the Web Preference link to display the Web Management Preferences panel.
5. Enable or disable elements on the Web management interface by clicking on the appropriate radio buttons on the panel. The following figure identifies the elements you can change.

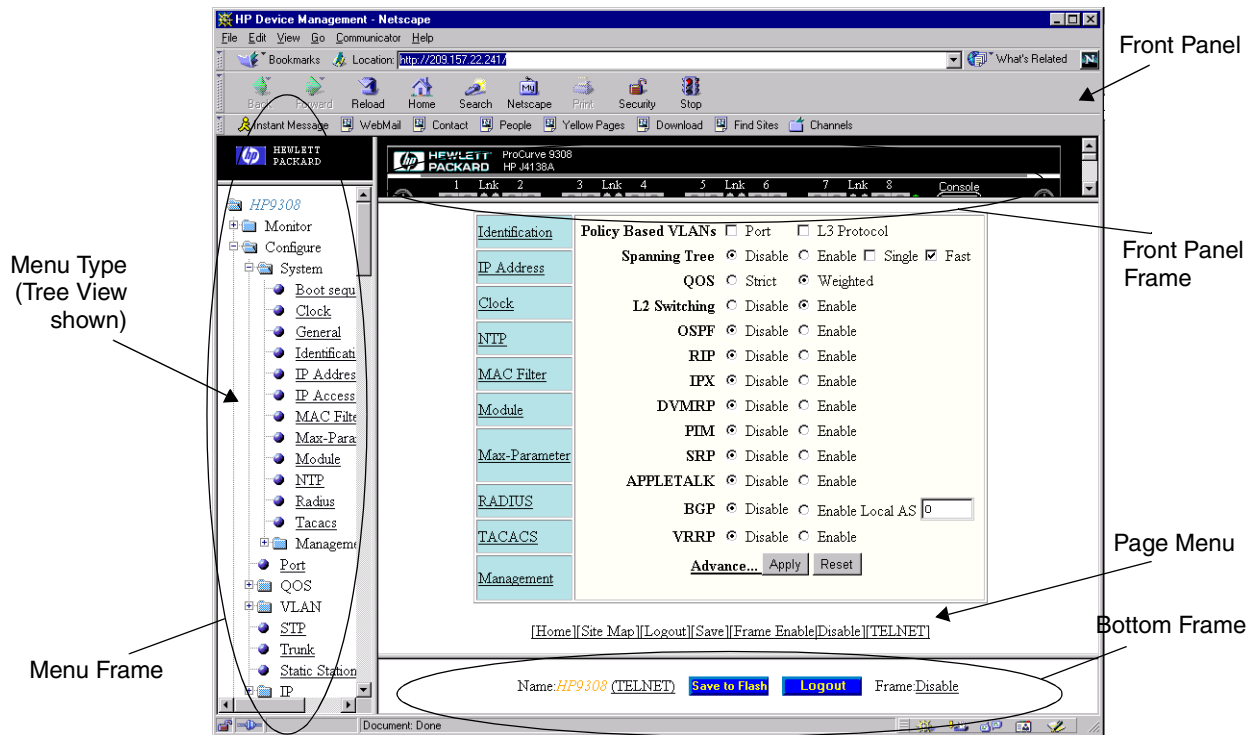

NOTE: The tree view is available when you use the Web management interface with Netscape 4.0 or higher or Internet Explorer 4.0 or higher browsers. If you use the Web management interface with an older browser, the Web management interface displays the List view only, and the Web Management Preferences panel does not include an option to display the tree view.

6. When you have finished, click the Apply button on the panel, then click the Refresh button on your browser to activate the changes.

-
- To save the configuration, click the plus sign next to the Command folder, then click the [Save to Flash](#) link.

NOTE: The only changes that become permanent are the settings to the Menu Type and the Front Panel Frame. Any other elements you enable or disable will go back to their default settings the next time you start the Web management interface.

13. Swapping Modules (Chassis Devices only)

After you physically insert a module into a Chassis device, you need to enter the location and type of module in the software, unless you either reboot the device or are replacing one module with another of the same type.

- Slots on the HP 9304M are numbered 1 – 4, from top to bottom.
- Slots on the HP 9308M are numbered 1 – 8, from left to right.

See “Slot and Port Numbers” on page 7-8 for more information about slot and port numbering.

NOTE: If the slot has never contained a module or you are swapping in exactly the same type of module, you do not need to use the **module** command. The slot requires configuration only if it has already been configured for another type of module.

USING THE CLI

To add a module to a Chassis device:

```
HP9300(config)# module 3 24-port-copper-module
```

Syntax: module <slot-num> <module-type>

The <slot-num> parameter indicates the Chassis device slot number.

The <module-type> parameter can be one of the following. You can, of course, take advantage of the CLI's support for abbreviated command and parameter names.

NOTE: Some module strings apply to more than one module. This is because the slot configuration does not differ based on the physical layer. For example, a slot does not distinguish between an 8-port LX Fiber module and 8-port SX Fiber module. However, the software does indicate the physical layer type when you display module information. For example, the output of the **show module** command indicates the physical layer types of each module.

Table 2.3: Module Options

Module Type	Part Number and Description	Module String
Redundant Management modules	J4845A HP ProCurve 9300 GigLX Redundant Management Module (8-port)	8-port-gig-management-module
	J4846A HP ProCurve 9300 GigSX Redundant Management Module (8-port)	8-port-gig-management-module
	J4847A J4847A HP ProCurve 9300 Redundant Management Module (0-port)	0-port-management-module
Management modules	J4141A ProCurve 9300 10/100 Management Module (16-port)	16-port-copper-management-module
	J4144A HP ProCurve 9300 Gigabit SX Management Module (8-port)	8-port-gig-management-module
	J4146A HP ProCurve 9300 Gigabit 4LX/4SX Management Module (8-port)	8-port-gig-management-module

Table 2.3: Module Options (Continued)

Module Type	Part Number and Description	Module String
Unmanaged modules	J4842A ProCurve 9300 1000Base-T Module (8-port)	8-port-gig-copper-module
	J4140A HP ProCurve 9300 10/100 Module (24-port)	24-port-copper-module
	J4142A HP ProCurve 9300 100Base FX Module (24-port MT-RJ)	24-port-100fx-module
	J4143A HP ProCurve 9300 Gigabit SX Module (8-port)	8-port-gig-module
	J4145A HP ProCurve 9300 Gigabit 4LX/ 4SX Module (8-port)	8-port-gig-module
	J4844A HP ProCurve 9300 GigLX Module (8-port)	8-port-gig-module

USING THE WEB MANAGEMENT INTERFACE

To configure a chassis slot for a module:

1. Log on to the device using a valid user name and password for read-write access. The System configuration panel is displayed.
2. Click on the Module link to display the Module panel, as shown in the following example.

Module

Slot	Module	Status	Ports	Starting MAC	
1	8 Port Gig Management Module	OK	8	00e0.52f0.4f00	Delete
2	None				Delete
3	24 Port Copper Module	OK	24	00e0.52f0.4f40	Delete
4	24 Port Copper Module	OK	24	00e0.52f0.4f60	Delete
5	None				Delete
6	None				Delete
7	None				Delete
8	None				Delete

[\[Add Module\]](#)

[\[Home\]](#) [\[Site Map\]](#) [\[Logout\]](#) [\[Save\]](#) [\[Frame Enable\]](#) [\[Disable\]](#) [\[TELNET\]](#)

3. Click the Add Module link to display the following panel.

Module

Slot:	1
Module Type:	8-port-gig-module

[\[Show\]](#)

[\[Home\]](#) [\[Site Map\]](#) [\[Logout\]](#) [\[Save\]](#) [\[Frame Enable\]](#) [\[Disable\]](#) [\[TELNET\]](#)

4. Select slot number from the Slot pulldown menu.
 - Slots on the HP 9304M are numbered 1 – 4, from top to bottom.
 - Slots on the HP 9308M are numbered 1 – 8, from left to right.
5. Select the module type from the Module Type pulldown menu.
6. Click the Add button to save the change to the device's running-config file.
7. Select the Save link at the bottom of the dialog. Select Yes when prompted to save the configuration change to the startup-config file on the device's flash memory.

14. Next Steps

Once the initial installation steps are completed, you can proceed with enabling routing protocols and configuring specific features on the switch or routing switches as described in “Configuring Basic Features” on page 8-1.

Configuration details for all routing protocols and advanced VLAN features can be found in the *Advanced Configuration and Management Guide*.

