

# HP ProCurve High-Speed Transceivers Installation Guide

---

## Introduction

The HP ProCurve High-Speed Transceivers can be installed into a number of HP ProCurve networking devices to provide 100 Mbps and 1000 Mbps connections to other compatible network devices.

This document describes how to install, verify, and troubleshoot the following HP ProCurve High-Speed Transceivers:



HP J4131A ProCurve Gigabit-SX Transceiver

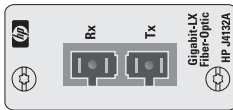

HP J4132A ProCurve Gigabit-LX Transceiver



HP J4834A ProCurve 100/1000-T Transceiver

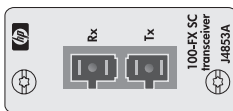

HP J4853A ProCurve 100-FX SC Transceiver

Use these transceivers for the following network connectivity:

- Gigabit-SX transceiver—1000 Mbps operation over multimode fiber-optic cable
- Gigabit-LX transceiver—1000 Mbps operation over either single-mode or multimode fiber-optic cable
- 100/1000-T transceiver—1000 or 100 Mbps operation over Category 5 or better unshielded twisted-pair (UTP) or shielded twisted-pair (STP) cables
- 100-FX SC transceiver—100 Mbps operation over multimode fiber-optic cable

For more information on the cables used with these transceivers and the supported cable lengths, see page 4.

## Installation Notes

*Please read these notes before proceeding.*

- The illustrations in this document show the transceivers being used a small number of the HP networking devices that are designed to accept them. But, the procedures pertain to using these transceivers in all the HP networking devices that accept them.

The HP ProCurve High-Speed Transceivers are supported in the HP ProCurve networking devices as shown in the following table:

	<b>Switch 2424M Gigabit Stacking Module*</b>	<b>Series 2300 and 2500 Switches</b>
<b>Gigabit-SX Transceiver</b>	supported	supported
<b>Gigabit-LX Transceiver</b>	supported	supported
<b>100/1000-T Transceiver</b>	NOT supported	supported
<b>100-FX SC Transceiver</b>	NOT supported	supported

- For all of the networking devices that support the HP ProCurve High-Speed Transceivers, it is *not* necessary to turn off power to the device before installing the transceiver into it:
  - For the Switch 2424M Gigabit Stacking Module\*, you can leave the power on to the switch, but remove the module from the switch before installing transceivers into it. Reinstalling the module into the switch initializes and activates the transceivers.
  - For the Series 2300 and 2500 switches, you can install the transceivers while the switches are powered on, but you must reset or reboot the switch after installing the transceiver to initialize and activate it.
  - For other HP ProCurve network devices, the transceivers may be fully “hot swappable”—you can install or remove them at any time without having to remove power from the device and without having to reset the device.

Please see the installation guide for the networking device for more information on installing the transceivers.

\* The Switch 2424M Gigabit Stacking Module (J4130A) provides transceiver connectivity only for an HP ProCurve Switch 2424M (J4093A).

# Installation Steps

To install the HP ProCurve High-Speed Transceivers, follow these steps:

1. Insert the transceiver into an HP networking device's transceiver slot and secure the retaining screws.
2. If the transceiver slot is in a module, install the module into the switch.
3. As necessary for the type of networking device into which the transceivers are installed, reset or reboot device.
4. Connect the network cable to the transceiver and check the transceiver and network device for correct operation.

Details on these steps are provided in the rest of this document.

## Insert the Transceiver Into the Slot

The transceivers are installed into an HP networking device, as follows:

1. If you are installing the transceiver into the HP ProCurve 2424M Gigabit Stacking Module, first remove the module from the switch. Then, for that module and for all other networking devices, using a flat-bladed or Torx T-10 screwdriver, unscrew the two retaining screws on the slot cover plate or existing transceiver, and remove it from the module or device.

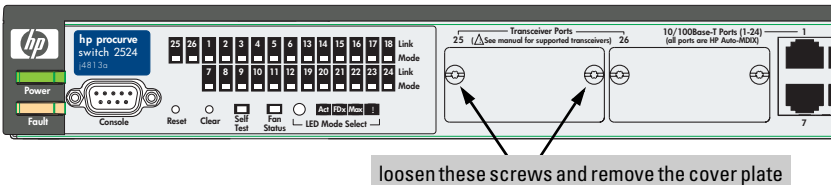

2. Touch a grounded, metal object (such as a powered-on switch) to discharge any static electricity on your body, then carefully remove the transceiver from its protective anti-static packaging. Hold the transceiver by its bulkhead or edges, taking care not touch any of its board components or metal connectors.

- Slide the transceiver firmly into the transceiver slot as far as it will go. The transceiver will “snap” into place, and the transceiver's faceplate should touch the face of the device. The following illustration shows the transceiver being installed in an HP ProCurve Switch 2524.

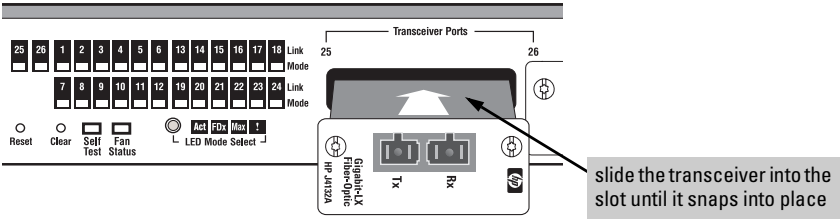

- Using the flat-bladed or Torx T-10 screwdriver, tighten the retaining screws on the transceiver until they are secure, but *be careful that you do not overtighten the screws*.
- If the transceiver is installed in a Gigabit Stacking Module, reinstall the module into the switch and make sure the switch is powered on, or if the transceiver is installed directly into a switch, reset the switch, if necessary, to initialize the transceivers. Please see the Installation Notes on page 2 for information about initializing the transceivers in different HP ProCurve networking devices.

## Connect Network Cables to the Transceiver Port

The network cables identified in the table on the next page should be used with the HP ProCurve High-Speed Transceivers.

Port Type	Cable Type	Length Limits
<b>Fiber-Optic Cables</b>		
Gigabit-SX	62.5/125 $\mu\text{m}$ or 50/125 $\mu\text{m}$ core/cladding diameter, graded-index, <b>multimode</b> fiber-optic cables that are fitted with SC connectors—the cables must comply with the ITU-T G.651 and ISO/IEC 793-2 Type A1b or A1a standards.	<ul style="list-style-type: none"> <li>• 62.5 <math>\mu\text{m}</math> cable: <ul style="list-style-type: none"> <li>– 160 MHz*km = 220 meters</li> <li>– 200 MHz*km = 275 meters</li> </ul> </li> <li>• 50 <math>\mu\text{m}</math> cable: <ul style="list-style-type: none"> <li>– 400 MHz*km = 500 meters</li> <li>– 500 MHz*km = 550 meters</li> </ul> </li> </ul>
Gigabit-LX	<p><b>single-mode</b> cables fitted with SC connectors—the cables must comply with the ITU-T G.652 and ISO/IEC 793-2 Type B1 standards.</p> <p>The multimode cables specified for the Gigabit-SX Transceiver may also be used, but a <b>mode conditioning patch cord</b> may be needed — see “Mode Conditioning Patch Cord” on page 9 for more information.</p>	<ul style="list-style-type: none"> <li>• single-mode cable - 5 kilometers</li> <li>• multimode cable - 550 meters</li> </ul>
100-FX SC	62.5/125 $\mu\text{m}$ or 50/125 $\mu\text{m}$ core/cladding diameter, graded-index, <b>multimode</b> fiber-optic cables that are fitted with SC connectors—the cables must comply with the ITU-T G.651 and ISO/IEC 793-2 Type A1b or A1a standards.	<ul style="list-style-type: none"> <li>• 2 kilometers for full-duplex connections</li> <li>• 412 meters for half-duplex connections</li> </ul> <p><b>Note:</b> The Series 2300 and 2500 switches do <i>not</i> allow half-duplex operation for the transceivers.</p>
<b>Twisted-Pair Cables</b>		
100/1000-T	<p>Category 5 or better, 100-ohm UTP or STP balanced cable. For 1000 Mbps (gigabit) operation, Category 5E cabling or better is recommended.</p> <p>Note: For 1000 Mbps operation, all four wire pairs are used for data transmissions.</p>	<p>100 meters</p> <p><b>Note:</b> The HP ProCurve 100/1000-T Transceiver is compatible with the IEEEab standard including the “Auto MDI/MDDI-X” feature, which allows you to use either straight-through or crossover twisted-pair cables for connection go any network device including end nodes, such as computers, or to other switches, hubs, and routers.</p>

### To connect a fiber-optic cable to a transceiver:

1. For fiber-optic transceivers, remove the plastic dust covers from the cable connectors and from the transceiver port.
2. Press the connector into the jack so that the tabs on the connector slide into the notches in the jack and the connector snaps securely into place.
3. If you are using cable with SC duplex connectors, as shown in the illustration, both cables are connected simultaneously. If the cable has simplex connectors, install them one at a time and make sure that the cable connected into the Tx (transmit) port on the transceiver is connected into the *receive* port on the device at the other end of the cable; similarly, make sure the Rx (receive) port on the transceiver is connected to the *transmit* port on the other device.

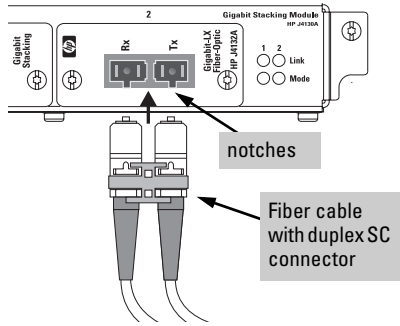

### To connect a twisted-pair cable to a transceiver:

Push the RJ-45 plug into the RJ-45 jack until the tab on the plug clicks into place.

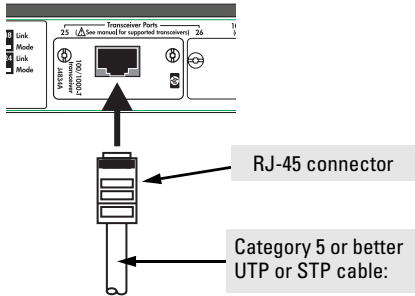

When power is applied to this transceiver and an active network cable is connected to the transceiver port, the Link LED for the port should be ON.

If the LED is off, see “Troubleshooting”, on the next page.

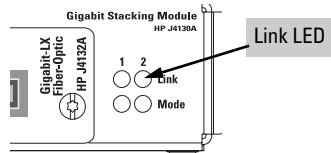

# Troubleshooting

The following problems may exist:

■ **The Link LED for the transceiver is not on, even though the transceiver is receiving power and the network cable is connected.** Check the following:

- Verify that the networked device at the other end of the cable is on.
- Verify that the cables are connected correctly to the transceiver ports. See step 3 in the installation instructions.
- Verify that the cable length does not exceed the maximum distances listed on page 4.
- Check all cabling and connections (including patch panels) to make sure that all connections are secure, no connectors are damaged, and that none of the connectors have a dust buildup or other object in the way that may cause interference to the light transmission or electrical connections. If all connections are OK, try a different cable.
- Verify that the networked device connected to the transceiver is the correct type for the transceiver used.
- Verify that the transceiver is supported by the switch or module into which you are installing it. See the table on page 2 to identify which transceivers are supported by which network devices.
- Try resetting or cycling power (turn the power off and then back on) on the networking device in which the transceivers are installed. If the transceiver is being used in a Gigabit Stacking Module and the module has been “hot swapped” into the Switch 2424M, the resulting self test does not test the transceivers. Resetting the switch causes a complete self test to be performed, which *does* test the transceivers.

■ **The switch Link LED for the transceiver port is blinking.** This condition occurs on the Series 2300 and 2500 switches. After installing the transceiver, these switches must be reset or rebooted to initialize the transceiver. The flashing LED tells you that the transceiver is not operational until the switch is reset or rebooted.

■ **The switch Fault LED and Link LED for the transceiver port are blinking.** The transceiver may not be installed correctly, or may be faulty. Disconnect power from the networking device and reinstall the transceiver into the module or networking device. Verify the transceiver screws are tightened. Turn the device power back on, and if the flashing persists, the transceiver may be faulty.

For additional troubleshooting, you can also use the device's console interface, the switch's web browser interface, or HP Top Tools for Hubs & Switches to troubleshoot and configure the High-Speed Transceiver port. See the switch's *Management and Configuration Guide* for more information.

If you are still having trouble, see the “Customer Support Services” on page 7.

# Specifications for the HP ProCurve High-Speed Transceivers

## Laser

The Gigabit-SX and Gigabit-LX transceivers are Class 1 Laser Products (Laser Klasse 1). They comply with IEC 825-2: 1993.

## Environmental

	Operating	Non-Operating
<b>Temperature:</b>	0°C to 55°C (32°F to 131°F)	-40°C to 70°C (-40°F to 158°F)
<b>Relative humidity: (non-condensing)</b>	15% to 95% at 40°C (104°F)	15% to 90% at 65°C (149°F)
<b>Maximum altitude:</b>	4.6 km (15,000 ft)	4.6 km (15,000 ft)

## Electromagnetic

### Emissions

FCC part 15 Class A

EN55022 / CISPR-22 Class A

VCCI Class A

Complies with Canadian EMC Class A requirements

As described on page 2 of this document, these transceivers are designed for operation with HP ProCurve networking products with compatible transceiver slots, and are listed in the Declaration of Conformity for those products. See the *Installation Guide* for the network products for a copy of the declaration and for other EMC statements.

## Standards

- The **Gigabit-SX Transceiver** is compatible with the IEEE 802.3z Gigabit-SX standard. It transmits at 850 nm wavelength and accepts the multimode fiber-optic cables for Gigabit-SX described on page 4.
- The **Gigabit-LX Transceiver** is compatible with the IEEE 802.3z Gigabit-LX standard. It transmits at 1300 nm wavelength and accepts the single-mode or multimode fiber-optic cables for Gigabit-LX described on page 4.
- The **100/1000-T Transceiver** is compatible with the IEEE 802.3ab 1000Base-T and IEEE 802.3u standards for 1000 Mbps and 100 Mbps operation, respectively.
- The **100-FX SC Transceiver** is compatible with the IEEE 802.3u 100Base-FX standard. It transmits at 1300 nm wavelength and accepts the multimode fiber-optic cables described on page 4.

## Mode Conditioning Patch Cord for Gigabit-LX

*The following information applies to installations in which multimode fiber-optic cables are connected to a Gigabit-LX Transceiver.*

Unlike Gigabit-SX, which connects to only multimode fiber-optic cabling, Gigabit-LX can use either single-mode or multimode cable. Multimode cable has a design characteristic called “Differential Mode Delay”, which requires that the transmission signals be “conditioned” to compensate for the cable design and thus prevent resulting transmission errors. Since Gigabit-SX is designed to operate only with multimode cable, Gigabit-SX transceivers can provide that transmission conditioning internally.

Gigabit-LX transceivers, since they are designed to operate with both single-mode and multimode cable, do not provide the transmission conditioning internally. Thus, under certain circumstances, depending on the cable used and the lengths of the cable runs, an external **Mode Conditioning Patch Cord** may need to be installed between the Gigabit-LX transmitting device and the multimode network cable to provide the transmission conditioning.

If you experience a high number of transmission errors on the Gigabit-LX ports, usually CRC or FCS errors, you may need to install one of these patch cords between the Gigabit-LX port in your switch and your multimode fiber-optic network cabling, *and between the Gigabit-LX transmission device and the network cabling at the other end of the multimode fiber-optic cable run. A patch cord must be installed at both ends.*

The patch cord consists of a short length of single-mode fiber cable coupled to graded-index multimode fiber cable on the transmit side, and only multimode cable on the receive side. The section of single-mode fiber is connected in such a way that it minimizes the effects of the differential mode delay in the multimode cable.

---

### Note

Most of the time, if you are using good quality graded-index multimode fiber cable that adheres to the standards listed on page 5, there should not be a need to use mode conditioning patch cords in your network. This is especially true if the fiber runs in your network are relatively short.

If you are using *single-mode* fiber-optic cabling in your network, there is no need to use mode conditioning patch cords. Connect the single-mode network cable directly to the Gigabit-LX transceiver.

---

## Installing the Patch Cord

As shown in the illustration below, connect the patch cord to the Gigabit-LX Transceiver with the section of single-mode fiber plugged in to the Tx (transmit) port. Then, connect the other end of the patch cord to your network cabling patch panel, or directly to the network multimode fiber.

If you connect the patch cord directly to the network cabling, you may need to install a **female-to-female adapter** to allow the cables to be connected together.

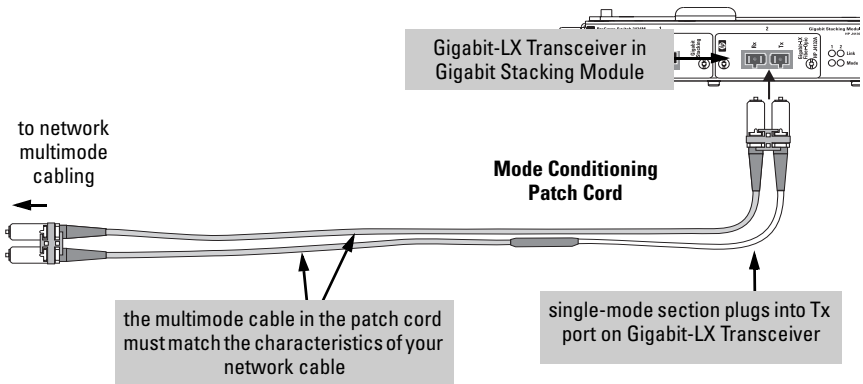

Make sure you purchase a patch cord that has SC connectors on the end that connects to the Gigabit-LX Transceiver and has multimode fibers that match the characteristics of the multimode fiber in your network.

**Recommended Patch Cords.** The following Mode Conditioning Patch Cords have been tested and verified to operate correctly with the HP Gigabit-LX Transceiver:

	Part Number	Connectors	Multimode Section Fiber Type
Computer Crafts	• MCP07071-002	SC-SC	62.5/125 $\mu\text{m}$
	• MCP07072-002	SC-SC	50/125 $\mu\text{m}$
	• MCP01071-002	SC-ST	62.5/125 $\mu\text{m}$
	• MCP01072-002	SC-ST	50/125 $\mu\text{m}$

These part numbers could change. Contact Computer Crafts through the world wide web at [www.computer-crafts.com](http://www.computer-crafts.com). A number of other vendors provide mode conditioning patch cords including Siecor, Inc. which can be contacted at [www.siecor.com](http://www.siecor.com).

## Customer Support Services

If you are having any trouble with your transceiver, Hewlett-Packard offers support 24 hours a day, seven days a week through the use of a number of automated electronic services. See the Customer Support/Warranty booklet that came with your transceiver for information on how to use these services to get technical support. The HP networking products World Wide Web site, <http://www.hp.com/go/procurve> also provides up-to-date support information and contact phone numbers. Click on the  button on that web page.

Additionally, your HP-authorized network reseller can also provide you with assistance, both with services that they offer and with services offered by HP.



Technical information in this document is subject to change without notice.

Copyright Hewlett-Packard Company, 2000. All rights reserved. Reproduction, adaptation, or translation without prior written permission is prohibited except as allowed under the copyright laws.

Printed in Singapore, 09/2000

Manual Part Number  
5969-2336

