HP ProCurve
Switch 1600M and 2400M

Installation Guide

© Copyright 1998 Hewlett-Packard Company
All Rights Reserved.

This document contains information which is protected by copyright. Reproduction, adaptation, or translation without prior permission is prohibited, except as allowed under the copyright laws.

Publication Number

5967-6915
June 1998

Applicable Products

HP ProCurve Switch 1600M (HP J4120A)
HP ProCurve Switch 2400M (HP J4122A)

Disclaimer

The information contained in this document is subject to change without notice.

HEWLETT-PACKARD COMPANY MAKES NO WARRANTY OF ANY KIND WITH REGARD TO THIS MATERIAL, INCLUDING, BUT NOT LIMITED TO, THE IMPLIED WARRANTIES OF MERCHANTABILITY AND FITNESS FOR A PARTICULAR PURPOSE. Hewlett-Packard shall not be liable for errors contained herein or for incidental or consequential damages in connection with the furnishing, performance, or use of this material.

Hewlett-Packard assumes no responsibility for the use or reliability of its software on equipment that is not furnished by Hewlett-Packard.

Warranty

See the Customer Support/Warranty booklet included with the product.

A copy of the specific warranty terms applicable to your Hewlett-Packard products and replacement parts can be obtained from your HP Sales and Service Office or authorized dealer.

Contents

1 Introducing the HP ProCurve Switch 1600M and 2400M

Front of the Switches	1-2
Network Ports	1-2
LEDs	1-3
Mode Select Button and Indicator LEDs	1-4
Console Port	1-5
Reset Button	1-5
Clear Button	1-5
Back of the Switch	1-6
Power Connector	1-6
Switch Features	1-7
Switch Operation Overview	1-8
Address Table Operation	1-8
Simultaneous Network Communications	1-9
Effect of VLANs	1-9

2 Installing the Switch 1600M and 2400M

Included Parts	2-1
Installation Procedures	2-2
Summary	2-2
Installation Precautions:	2-3
1. Prepare the Installation Site	2-4
2. Install Switch Module (optional on Switch 1600M only)	2-5
3. Verify the Switch Passes Self Test	2-6
LED Behavior:	2-7
4. Mount the Switch	2-8
Rack or Cabinet Mounting	2-8
Horizontal Surface Mounting	2-10
Wall Mounting	2-11
5. Connect the Switch to a Power Source	2-11

6. Connect the Network Cables	2-12
Using the RJ-45 Connectors (10/100Base-TX ports)	2-12
Connecting Cables to the Switch Module (Switch 1600M only)	2-12
7. (Optional) Connect a Console to the Switch	2-13
Terminal Configuration	2-13
Direct Console Access	2-14
Telnet Console Access	2-14
Hot Swapping the Switch Module (Switch 1600M only)	2-15
Adding or Replacing the Module	2-15
Changing the Module Type	2-15
Where to Go From Here	2-16

3 Troubleshooting

Basic Troubleshooting Tips	3-2
Diagnosing with the LEDs	3-4
Proactive Networking	3-7
Hardware Diagnostic Tests	3-8
Testing the Switch by Resetting It	3-8
Checking the Switch LEDs	3-8
Checking Console Messages	3-8
Testing Twisted-Pair Cabling	3-9
Testing Switch-to-Device Network Communications	3-9
Testing End-to-End Network Communications	3-10
Restoring the Factory Default Configuration	3-10
HP Customer Support Services	3-11

A Specifications

Physical	A-1
Electrical	A-1
Environmental	A-1
Acoustic	A-2
Connectors	A-2
Safety	A-2

B Cables and Connectors

Twisted-Pair Cable/Connector Pin-Outs	B-1
Twisted-Pair Cable for Switch (MDI-X) to Computer (MDI) Network Connection	B-2
Twisted-Pair Cable for Switch (MDI-X) to Hub or Switch (MDI-X) Network Connection	B-3
Twisted-Pair Cable Pin Assignments	B-4
Twisted-Pair Straight-Through Cable	B-4
Twisted-Pair Cross-Over Cable	B-4
Fiber-Optic Cables	B-5
10Base-FL Ports	B-5
100Base-FX Ports	B-5
Gigabit-SX Ports	B-5

C Safety and EMC Regulatory Statements

Safety Information	C-1
Informations concernant la sécurité	C-2
Hinweise zur Sicherheit	C-3
Considerazioni sulla sicurezza	C-4
Consideraciones sobre seguridad	C-5
Safety Information (Japan)	C-6
Safety Information (China)	C-7
EMC Regulatory Statements	C-8
U.S.A.	C-8
Canada	C-8
Australia/New Zealand	C-8
Japan	C-8
Korea	C-9
Taiwan	C-9
European Community	C-10

Index

Introducing the HP ProCurve Switch 1600M and 2400M

The HP ProCurve Switch 1600M and 2400M are multiport switches that can be used to build high-performance switched workgroup networks. These switches are store-and-forward devices that offers low latency for high-speed networking.

HP ProCurve Switch 1600M
(HP J4120A)

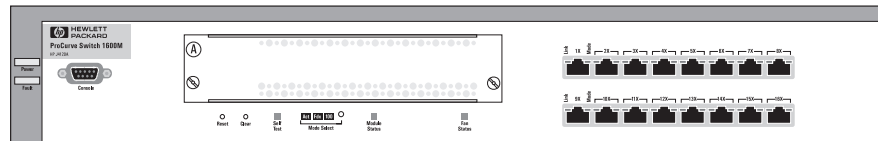

HP ProCurve Switch 2400M
(HP J4122A)

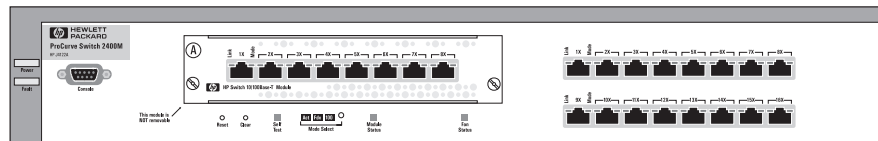

Throughout this manual, these switches will be abbreviated as the Switch 1600M and Switch 2400M, or when common features are being described, as the Switch 1600M and 2400M.

The Switch 1600M has 16 autosensing 10/100Base-T ports, and a universal slot for installing any of the supported switch modules (see page 1-7).

The Switch 2400M has 24 autosensing 10/100Base-T ports. (The 10/100Base-T Module installed in the Switch 2400M is fixed in place and cannot be removed.)

With these switches you can build a switched network infrastructure by connecting them to hubs, other switches, or routers, or you can connect computers, printers, and servers to these switches to provide dedicated bandwidth to those devices.

This chapter describes your HP Switch 1600M and 2400M including:

- Front and back of the switch
- Features
- Switch operation overview

Front of the Switches

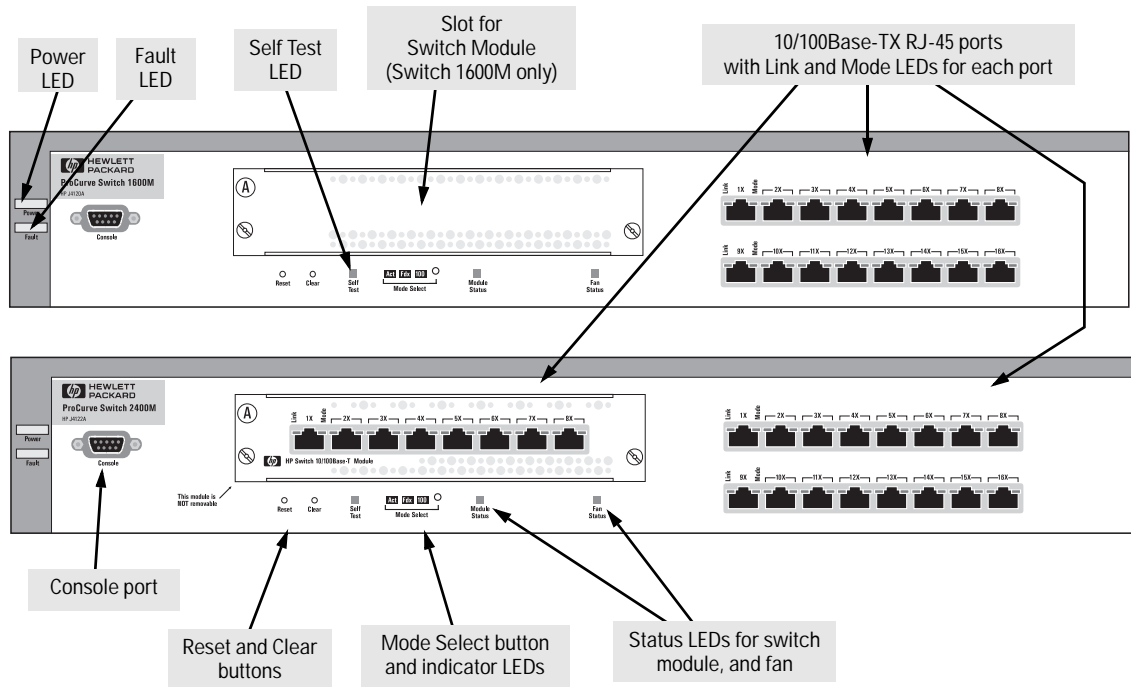

Network Ports

- 16 or 24 autosensing 10/100Base-TX ports
- on the Switch 1600M only, one universal switch module slot for installing any of the supported switch modules (see “Features” on page 1-7).

LEDs

Table 1-1. Switch LEDs

Switch LEDs	State	Meaning
Power (green)	On	The switch is receiving power.
	Off	The switch is NOT receiving power.
Fault (orange)	Off	The normal state; indicates that there are no fault conditions on the switch.
	Flashing [†]	A fault has occurred on the switch, the switch module (if installed), or a fan. The Status LED for the device with the fault will flash simultaneously.
Self Test (green)	On	On briefly after the switch is powered on or reset, at the beginning of switch self test. If on for a prolonged time, the switch has encountered a fatal hardware failure, or has failed its self test. See chapter 3, "Troubleshooting" for more information.
	Flashing [†]	A component of the switch has failed its self test. The status LED for that component, for example a fan, and the switch Fault LED will flash simultaneously.
Mode Select (3 green LEDs)	Act	Indicates that the port Mode LEDs are displaying network activity information.
	Fdx	Indicates that the port Mode LEDs are lit for ports that are in Full Duplex Mode.
	100	Indicates that the port Mode LEDs are lit for ports that are operating at 100 Mbps.
Module Status (green)	On	A module is installed in the switch module slot and that the module is undergoing or has passed self test.
	Off	A module is not installed in the switch module slot.
	Flashing [†]	The module in the slot, for the Switch 1600M, or the fixed 10/100Base-T Module, for the Switch 2400M, has failed self test or is not installed properly. The switch Fault LED, and the Self Test LED may be flashing simultaneously. For the Switch 1600M, if the Module Status LED is flashing by itself, a different module type has been hot swapped into the slot without the switch being reset. See "Hot Swapping Switch Modules" on page 2-15.
Fan Status (green)	On	The cooling fans are operating normally.
	Flashing [†]	One or more of the cooling fans have failed. The switch Fault LED will be flashing simultaneously.
[†] The flashing behavior is an on/off cycle once every 1.6 seconds, approximately.		

Table 1-2. Switch Module LEDs

Port LEDs	State	Meaning
Link	On	Indicates the port is enabled and receiving a link beat signal (for the twisted-pair ports), or a strong enough light level (for the fiber-optic ports, if installed in the Switch 1600M) from the connected device.
	Off	One of these conditions exists: <ul style="list-style-type: none"> no active network cable is connected to the port the port is not receiving link beat or sufficient light the port has been disabled through the switch console, the web browser interface, or HP TopTools.
Mode		Displays network activity information, or whether the port is configured for Full Duplex operation, or 100 Mbps operation depending on the mode selected. See "Mode Select Button and Indicator LEDs" on the next page for more information.

Mode Select Button and Indicator LEDs

To optimize the amount of information that can be displayed for each of the switch ports without overwhelming you with LEDs, the Switch 1600M and 2400M use a Mode LED for each port. The operation of this LED is controlled by the Mode Select button, and the current setting is indicated by the Mode indicator LEDs near the button. Press the button to step from one mode to the next.

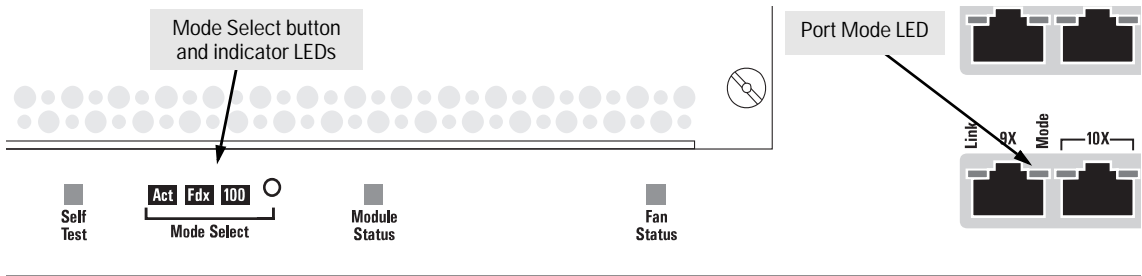

- If the Activity (Act) indicator LED is lit, each port Mode LED displays activity information for the port—it flickers as network traffic is received and transmitted through the port.
- If the Full Duplex (Fdx) indicator LED is lit, the port Mode LEDs light for those ports that are operating in full duplex.
- If the 100 Mbps (100) indicator LED is lit, the port Mode LEDs light for those ports that are operating at 100 Mbps.

Console Port

This port is used to connect a console to the switch by using the serial cable supplied with the switch. This connection is described under “Connecting a Console to the Switch” in chapter 2, “Installing the Switch 1600M and 2400M”. The console can be a PC running a VT-100 terminal emulator, or a VT-100 terminal.

Reset Button

This button is used to reset the switch while it is powered on. This action clears any temporary error conditions that may have occurred, executes the switch self test, and resets all network activity counters to zero. The counters are displayed in the switch console interface, the switch web browser interface, and through SNMP network management applications, such as HP TopTools for Hubs & Switches.

Clear Button

This button is used for these purposes:

- **Deleting Passwords** - When pressed by itself for at least one second, deletes any switch console access passwords that you may have configured. Use this feature if you have misplaced the password and need console access.

This button is provided for your convenience, but its presence means that if you are concerned with the security of the switch configuration and operation, you should make sure the switch is installed in a secure location, such as a locked wiring closet.

- **Restoring Factory Default Configuration** - When pressed with the Reset button in a specific pattern, clears any configuration changes you may have made through the switch console, the web browser interface, and SNMP management, and restores the factory default configuration to the switch. For the specific method to restore the factory default configuration, see “Restoring the Factory Default Configuration” in chapter 3, “Troubleshooting” of this manual.

Back of the Switch

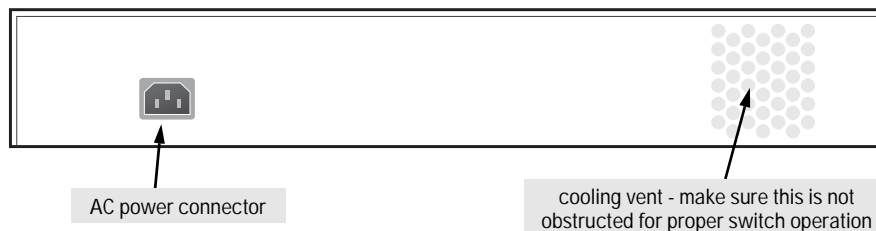

Power Connector

The Switch 1600M and 2400M do not have a power switch; they are powered on when connected to an active AC power source. The switches automatically adjust to any voltage between 100-127 and 200-240 volts and either 50 or 60 Hz. There are no voltage range settings required.

Switch Features

The features of the Switch 1600M and 2400M include:

- network ports for the 1600M:
 - 16 autosensing 10/100Base-TX RJ-45 ports
 - a universal slot for installing any of the available switch modules—as of this printing, this includes:
 - 8-port 10/100Base-TX Module (HP J4111A)
 - 4-port 100Base-FX Module (HP J4112A)
 - 1-port Gigabit-SX Module (HP J4113A)
 - 4-port 10Base-FL Module (HP J4118A)
 - the module is “hot swappable”
- network ports for the 2400M:
 - 24 autosensing 10/100Base-TX RJ-45 ports
- plug-and-play networking—all ports are enabled—just connect the network cables to active network devices and your switched network is operational
- automatic learning of the network addresses in the switch’s 8000-address forwarding table, with configurable address aging value
- configurable full-duplex operation of the 10 Mbps, 100 Mbps, and Gigabit ports (when a Gigabit-SX Switch Module is installed in the Switch 1600M)
- easy management of the switches through several available interfaces:
 - **web browser interface**—an easy to use built-in graphical interface that can be accessed from common web browsers
 - **console interface**—a full featured, easy to use, VT-100 terminal interface that is especially good for out-of-band switch management, or for telnet access to the switch
 - **HP TopTools for Hubs & Switches**—an SNMP-based graphical interface that is used to manage your entire network, included with your new switch
- support for the Spanning Tree Protocol to eliminate network loops
- support for up to 8 IEEE 802.1Q-compliant VLANs so you can divide the attached end nodes into logical groupings that fit your business needs
- support for many advanced features to enhance network performance—described in the *Management and Configuration Guide* that came with your switch.

Switch Operation Overview

Address Table Operation

Address Learning. As devices are connected to the switch ports, either directly or through hubs or other switches that are connected to the switches, the MAC addresses of those devices are learned automatically and stored in the 8000-entry address table featured by the Switch 1600M and 2400M. The switches also identify the number of the port on which each address is learned so they know the network location of each device.

Forwarding, Filtering, Flooding. When the switch receives a packet, it determines the destination address, looks for the address in the address table. Based on the port location of that address, the switch then determines whether to forward, filter-out, or flood the packet.

- **forward** - if the destination address is on a different port than the one on which the packet was received, the packet is forwarded to the destination port and on to the destination device.
- **filter out** - if the destination address is on the same port as the one on which the packet was received, the packet is filtered out. The switch thereby isolates local traffic so the rest of the network connected to the switch does not lose bandwidth dealing with unnecessary traffic.
- **flood** - whenever a new destination address is found in a packet, the destination address will not yet be in the switch's address table and the switch cannot know whether to forward or filter out the packet. In this case, it sends the packet to all the ports. This is referred to as "flooding". When the destination device receives the packet, it replies, and the switch learns the new address from the reply packet. Then, all future packets destined for that address are forwarded or filtered out appropriately.

Network Moves and Changes. When devices are moved in the network, and become connected to a different switch port, the Switch 1600M and 2400M automatically recognizes the change and updates the address table with the new port location of the device. Communication with the device is automatically maintained, without any address table manipulation being required.

Simultaneous Network Communications

In addition to traffic isolation benefits provided by the Switch 1600M and 2400M address table operation, the switch also enhances network performance because it can conduct multiple, simultaneous network connections. Instead of sharing the network bandwidth, as in connections to a hub, each connection has its own 10 Mbps, 100 Mbps, or 1000 Mbps bandwidth to use.

Effect of VLANs

If you configure multiple virtual LANs (VLANs) on the switch, each VLAN behaves as a “logical switch” containing the switch ports that you assign to it. Each logical switch behaves as an isolated broadcast domain, just as if it were a separate physical switch. The forward, filter, and flood behavior described for the physical switch above, operates the same for each of the logical switches defined by the VLANs: packets are forwarded or flooded only to the ports that are within a given VLAN. Just as for separate physical switches, there is no communication between ports that are in separate VLANs unless the VLANs are connected by an external router.

For more information on configuring VLANs and their behavior, see the *Management and Configuration Guide* that came with your switch.

Installing the Switch 1600M and 2400M

The HP Switch 1600M and 2400M are easy to install units. They each come with an accessory kit that includes the brackets for mounting the switch in a standard 19-inch telco rack or an equipment cabinet, or on a wall, and with rubber feet that can be attached so the switch can be securely located on a horizontal surface. The brackets are designed to allow mounting the switch in a variety of orientations.

This chapter shows you how to install your Switch 1600M and 2400M.

Included Parts

The Switch 1600M and 2400M have the following components shipped with them:

- *HP ProCurve Switch 1600M and 2400M Installation Guide* (5967-6915), this manual
- *HP ProCurve Management and Configuration Guide* (5967-2142 for the 1600M, and 5967-6914 for the 2400M)
- *HP TopTools for Hubs & Switches* - CD ROM and booklet
- Customer Support/Warranty booklet
- Accessory kit (5064-2085)
 - two mounting brackets
 - four 10 mm M4 screws to attach the mounting brackets to the switch
 - four 5/8-inch number 12-24 screws to attach the switch to a rack
 - four rubber feet
- Console cable
- Power cord, one of the following:

Australia/New Zealand	(8120-6803)
United Kingdom	(8120-6801)
China	(8120-8377)
Continental Europe	(8120-6802)
Denmark	(8120-6806)
Japan	(8120-6804)
Switzerland	(8120-6807)
United States/Canada/Mexico	(8120-6805)

Installation Procedures

Summary

Follow these easy steps to install your switch. The rest of this chapter provides details on these steps.

1. **Prepare the installation site (page 2-4).** Make sure that the physical environment into which you will be installing the switch is properly prepared including having the correct network cabling ready to connect to the switch, and having a good location for the switch. *Please see page 2-3 for some installation precautions.*
2. **Install switch module (optional on Switch 1600M only—page 2-5).** The Switch 1600M has a slot for installing any of the supported HP switch modules. Depending on where you will install the Switch 1600M, it may be easier to install the module first, but the modules are “hot swappable”—they can also be installed and removed after the switch is installed and powered on.
3. **Verify that the switch passes self test (page 2-6).** This is a simple process of plugging the switch into a power source and observing that the LEDs on the switch’s front panel and on the modules show correct operation.
4. **Mount the switch (page 2-8).** The Switch 1600M and 2400M can be mounted in a 19-inch telco rack, in an equipment cabinet, on a wall, or on a horizontal surface.
5. **Connect power to the switch (page 2-11).** Once the switch is mounted, plug it in to the nearby main power source.
6. **Connect the network devices (page 2-12).** Using the appropriate network cables, connect other switches, hubs, routers, computers, servers, printers, and other network devices to the switch ports.
7. **(Optional) Connect a console to the switch (page 2-13).** You may wish to modify the switches’ configuration, for example, to configure an IP address so they can be managed using a web browser, from an SNMP network management station, or through a telnet session to the switch console. Configuration changes can be made easily by using the included console cable to connect a PC to the switches’ console port.

At this point, the switch is fully installed and your network should be up and running. See the rest of this chapter if you need more detailed information on any of these installation steps.

Installation Precautions:

Follow these precautions when installing your HP Switch 1600M and 2400M.

Warning

- The rack or cabinet should be adequately secured to prevent it from becoming unstable and/or falling over.

Devices installed in a rack or cabinet should be mounted as low as possible, with the heaviest device at the bottom and progressively lighter devices installed above.

Cautions

- Make sure that the power source circuits are properly grounded, then use the power cord supplied with the switch to connect it to the power source.

If your installation requires a different power cord than the one supplied with the switch, be sure to use a power cord displaying the mark of the safety agency that defines the regulations for power cords in your country. The mark is your assurance that the power cord can be used safely with the switch.

- Ensure that the switch does not overload the power circuits, wiring, and over-current protection. To determine the possibility of overloading the supply circuits, add together the ampere ratings of all devices installed on the same circuit as the switch and compare the total with the rating limit for the circuit. The maximum ampere ratings are usually printed on the devices near the AC power connectors.
 - Do not install the switch in an environment where the operating ambient temperature might exceed 55°C (131°F).
 - Make sure the air flow around the sides and back of the switch is not restricted.
 - Make sure that if no module is installed in the module slot, the cover plate is installed to cover the slot. A cover plate is required for safe operation, and to ensure proper switch cooling.
-

1. Prepare the Installation Site

- Cabling Infrastructure** - Ensure that the cabling infrastructure meets the necessary network specifications. See the following table for cable types and lengths, and see appendix B, “Cables and Connectors” for more information:

Table 2-1. Summary of Cable Types to Use with the Switch

Port Type	Cable Type	Length Limits
10Base-T	category 3, 4, or 5, 100 ohm unshielded twisted-pair (UTP)	<ul style="list-style-type: none"> category 3, 4, or 5 - 100 meters <p>Note: Since the 10Base-T operation is through 10/100Base-TX ports, if you ever want to upgrade the ports to 100Base-T, it would be best to cable the ports initially with category 5 cable.</p> <p>For connecting these ports to end nodes or other MDI ports, use “straight-through” cable; for connecting to MDI-X ports on hubs or other switches, use “crossover” cable.</p>
10Base-FL (Switch 1600M only)	850 nm multimode fiber-optic cables that are fitted with ST connectors, and conform to ISO/IEC 793-2 type B1 and ITU-T G.652 standards	1 kilometer
100Base-TX	category 5, 100-ohm UTP or shielded twisted-pair (STP)	100 meters (See Note above on use of “straight-through” and “cross-over” cables.)
100Base-FX (Switch 1600M only)	1300 nm multimode fiber-optic cables that are fitted with SC connectors, and conform to ISO/IEC 793-2 type B1 and ITU-T G.652 standards	<ul style="list-style-type: none"> 412 meters for half-duplex connections 2 kilometers for full-duplex connections
Gigabit-SX (Switch 1600M only)	850 nm multimode fiber-optic cables that are fitted with SC connectors.	<ul style="list-style-type: none"> 62.5 μm cable - 220 meters 50 μm cable - 500 meters

- Installation Location** - Before installing the switch, plan its location and orientation relative to other devices and equipment. In the front of the switch, leave at least 7.6 cm (3 inches) of space for the twisted-pair and fiber-optic cabling. In the back of the switch, leave at least 3.8 cm (1 1/2 inches) of space for the power cord. On the sides, leave at least 3 inches for cooling.

2. Install Switch Module (optional on Switch 1600M only)

Install a switch module into the slot as shown in the illustration below. For installation details, see the instructions in the manual that comes with the module.

The slot cover can be removed with either a flat-bladed or Torx T-10 screwdriver. Retain the slot cover for future use.

Notes

- Any of the supported switch modules can be installed in the slot in the Switch 1600M.
- The module can be “hot swapped”, installed when the switch is powered on and normally will be immediately operational. But, if the new module is replacing a module of a different type that was previously installed in the slot, the switch must be rebooted after the new module is installed. See “Hot Swapping the Switch Module” on page 2-15.
- ***Make sure the module is fully installed and that you screw in the retaining screws to secure the module in place.***
- If you do not install a module in the slot, make sure that the slot cover plate is still attached over the slot for safe operation and proper switch cooling.

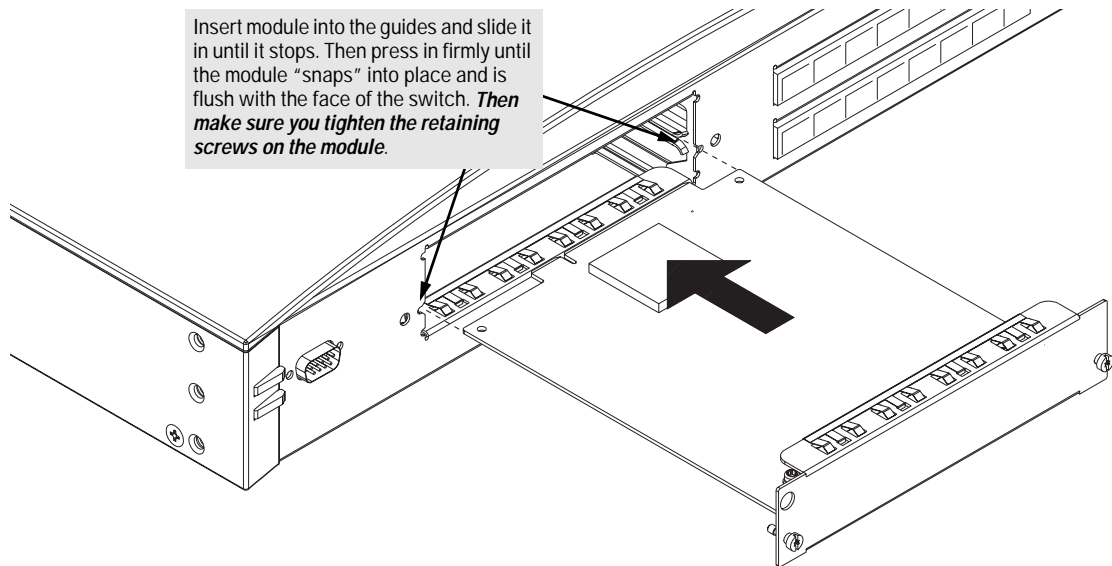

3. Verify the Switch Passes Self Test

Before mounting the switch in its network location, you should first verify that it is working properly by plugging it into a power source and verifying that it passes its self test.

1. Connect the power cord supplied with the switch to the power connector on the back of the switch, and then into a properly grounded electrical outlet.

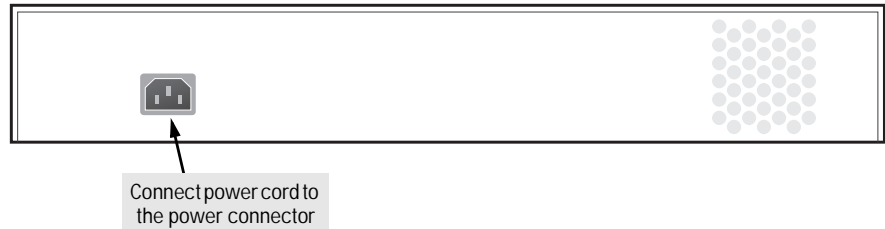

Note

The Switch 1600M and 2400M do not have a power switch. They are powered on when the power cord is connected to the switch and to a power source.

If your installation requires a different power cord than the one supplied with the switch, be sure to use a power cord displaying the mark of the safety agency that defines the regulations for power cords in your country. The mark is your assurance that the power cord can be used safely with the switch.

2. Check the LEDs on the switch and on the switch module (if installed in the Switch 1600M). The LED behavior is described on the next page.

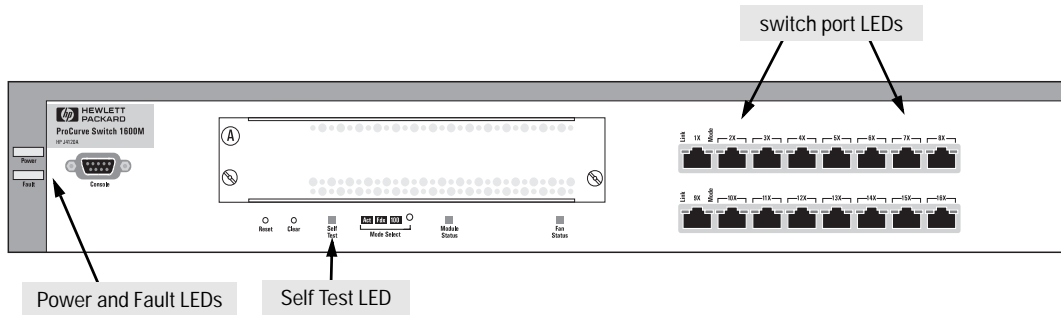

When the switch is powered on, it performs its diagnostic self test. The self test takes approximately 30 to 45 seconds to complete, depending on whether a switch module is installed in the slot in the Switch 1600M, and approximately 40 seconds to complete for the Switch 2400M.

LED Behavior:

During the self test:

- Initially, all the switch and port LEDs are on.
- After approximately 3 seconds most of the LEDs go off and then may come on again during phases of the self test. For the duration of the self test, the Self Test LED stays on.

When the self test completes successfully:

- The **Power** and **Fan Status** LEDs remain on.
- For the Switch 2400M, and for a Switch 1600M in which a module is installed, the **Module Status** LED also stays on.
- The **Fault** and **Self Test** LEDs on the switch go off.
- The port LEDs near the network ports and on the switch module go into their normal operational mode:
 - If the ports are connected to active network devices, the **Link** LEDs stay on and the **Mode** LEDs behave according to the mode selected. In the default mode (Activity), the Mode LEDs should flicker showing network activity on the port.
 - If the ports are not connected to active network devices, the LEDs will stay off.

If the LED display is different than what is described above, especially if the Fault and Self Test LEDs stay on for more than 60 seconds or they start flashing, the self test has not completed correctly. Refer to chapter 3, “Troubleshooting” for diagnostic help.

4. Mount the Switch

After you have verified that the switch passes self test, you are ready to mount the switch in a stable location. The Switch 1600M and 2400M can be mounted in these ways:

- in a rack or cabinet
- on a horizontal surface
- on a wall

Rack or Cabinet Mounting

The Switch 1600M and 2400M are designed to be mounted in any EIA-standard 19-inch telco rack or in an equipment cabinet such as a server cabinet.

Warning

For safe operation, please read the mounting precautions on page 2-3, before mounting a switch.

1. Use a #1 Phillips (cross-head) screwdriver and attach the mounting brackets to the switch with the included 10-mm M4 screws.

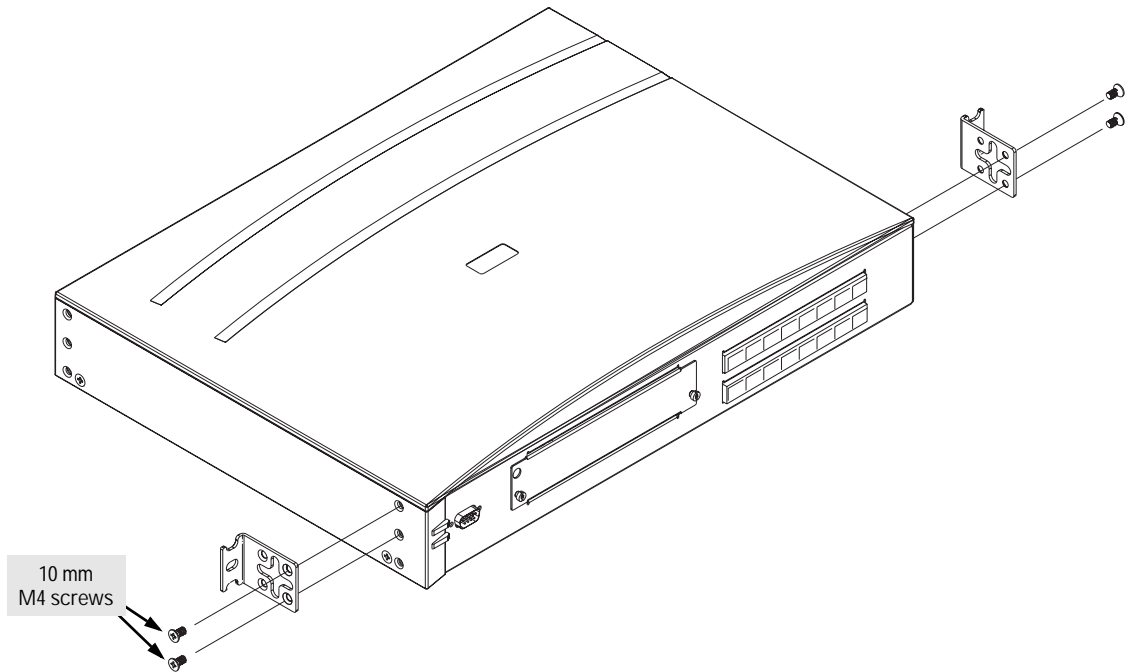

- Partially install a screw (5/8-inch number 12-24) into the top hole of a pair of holes that are 0.5 inches apart in each rack/cabinet upright as shown in the illustration below. Ensure that the screws are at the same level in each upright.

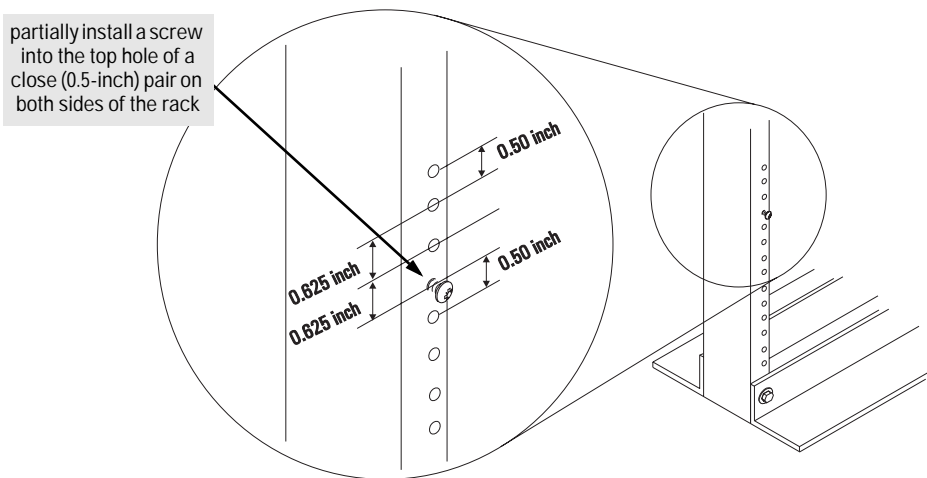

- Place the switch in the rack and lower it so the notches in the bottom of the bracket slide onto the screws, then tighten these screws.

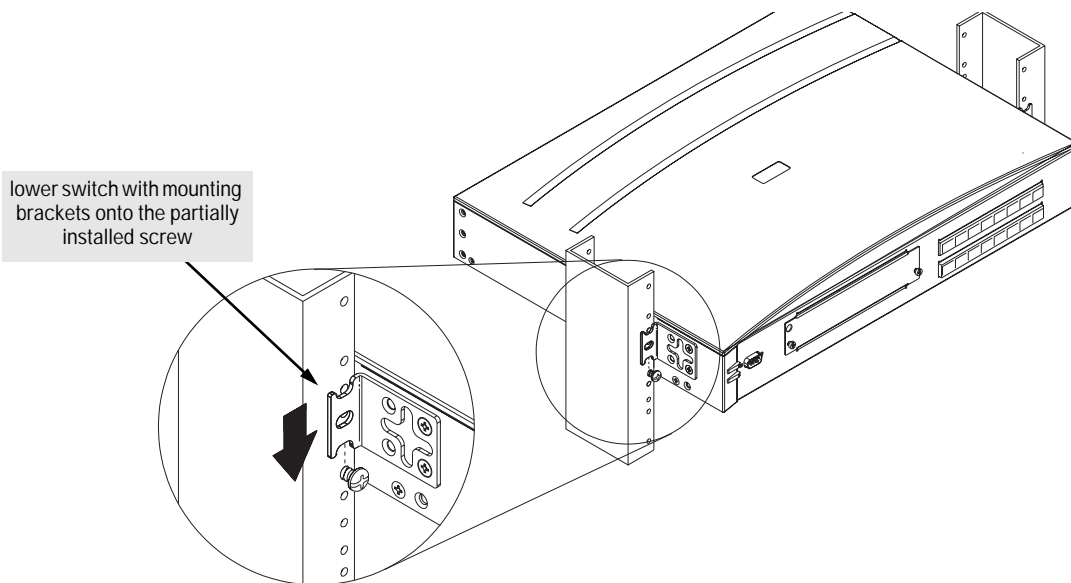

4. Install the other number 12-24 screw into the upper hole in each bracket. Tighten these screws.

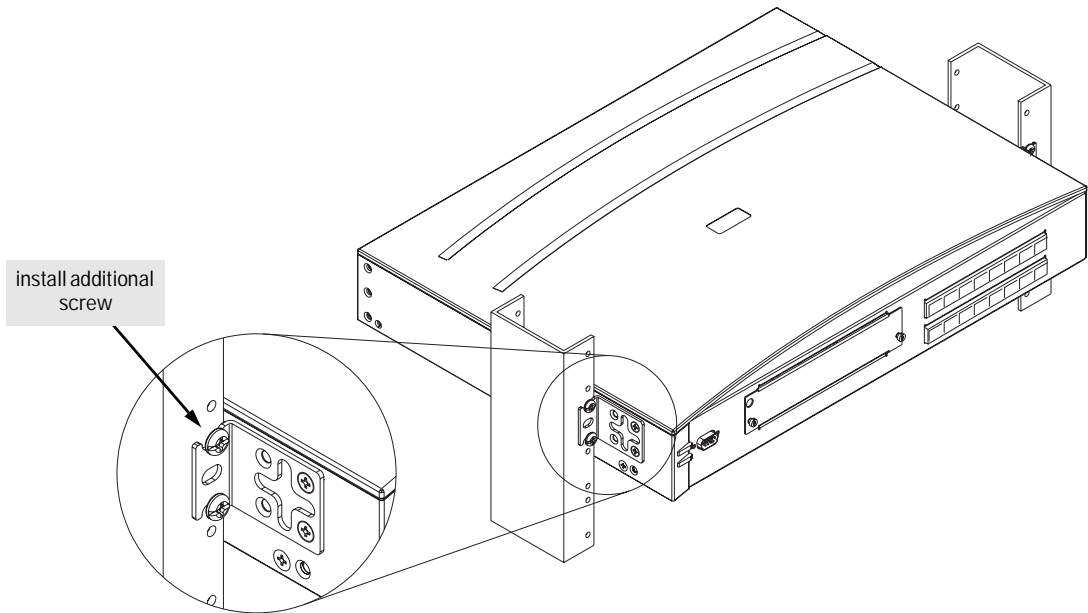

Horizontal Surface Mounting

Place the switch on a table or other horizontal surface. Use a sturdy surface in an uncluttered area. You may want to secure the networking cables and switch power cord to the table legs or other part of the surface structure to help prevent people from tripping over the cords.

Note

Make sure the air flow is not restricted around the sides and back of the switch.

Wall Mounting

You can mount the switch on a wall as shown in the illustration below.

Caution

The switch should be mounted only to a wall or wood surface that is at least 1/2-inch plywood or its equivalent.

1. Use a #1 Phillips (cross-head) screwdriver and attach the mounting brackets to the switch with the included 10-mm M4 screws.
2. Attach the switch to the wall or wood surface with two 5/8-inch number 12 wood screws (not included).

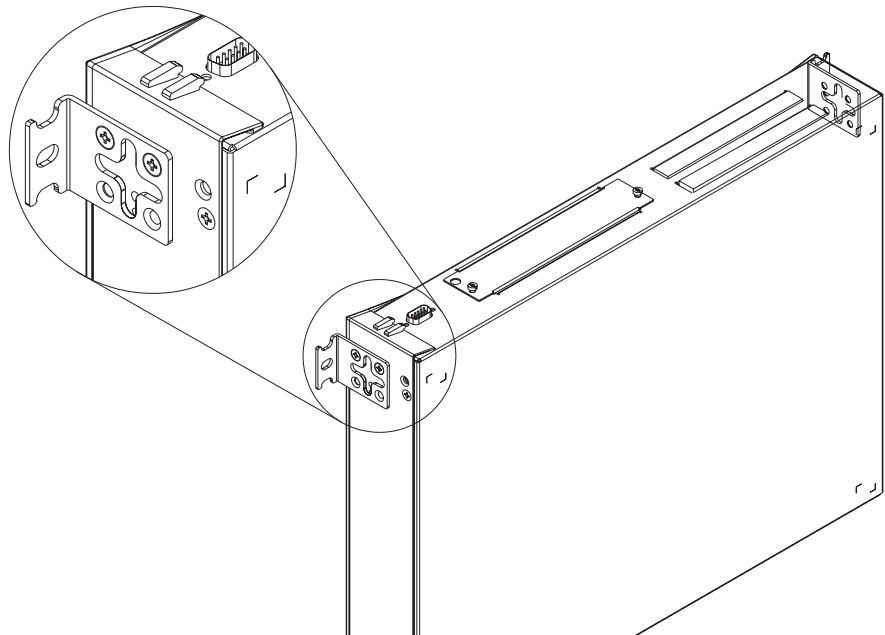

5. Connect the Switch to a Power Source

1. Plug the included power cord into the switch's power connector and into a nearby AC power source.
2. Re-check the LEDs during self test. See "LED Behavior" on page 2-7.

6. Connect the Network Cables

Using the RJ-45 Connectors (10/100Base-TX ports)

To connect:

Push the RJ-45 plug into the RJ-45 jack until the tab on the plug clicks into place. When power is on for the switch and for the connected device, the Link LED for the port should light to confirm a powered-on device (for example, an end node) is at the other end of the cable.

If the Link LED does *not* go on when the network cable is connected to the port, see “Diagnosing With the LEDs” in chapter 3, “Troubleshooting”.

To disconnect:

Press the small tab on the plug and pull the plug out of the jack.

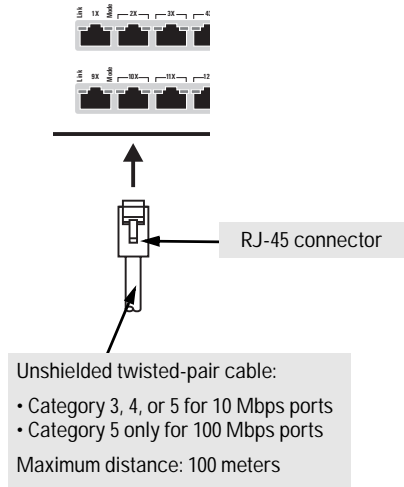

Connecting Cables to the Switch Module (Switch 1600M only)

If you have a switch module installed in the Switch 1600M, the type of network connections you will need to use depends on the type of module you have installed. See the documentation accompanying the modules for cabling configurations and procedures for those modules.

The module documentation will also cover troubleshooting procedures for connections to the module, but, in general for all the switch ports, when a network cable from an active network device is connected to the port, the Link LED for that port should go on. If the Link LED does *not* go on when the network cable is connected to the port, see “Diagnosing With the LEDs” in chapter 3, “Troubleshooting”.

7. (Optional) Connect a Console to the Switch

The Switch 1600M and 2400M have a full-featured, easy to use console interface for performing the following tasks:

- Monitor switch and port status and observe network activity counters
- Modify the switch's configuration
- Read the event log and access diagnostic tools to help in troubleshooting
- Download new software to the switch
- Add passwords to control console, web browser interface, and network management access to the switch

The console can be accessed through these methods:

- **Out-of-band:** The Switch 1600M and 2400M come with a serial cable for connecting a PC or VT-100 terminal to be used as a console directly to the switch. If the PC or terminal has a 25-pin serial connector, you can use a readily available 9-pin to 25-pin serial cable, or attach a 9-to-25 pin "straight-through" adapter to the end of the supplied cable.
- **In-Band:** Access the console using Telnet from a PC or UNIX station on the network, and a VT-100 terminal emulator. This method requires that you first configure the switch with an IP address and subnet mask by using either out-of-band console access or through DHCP/Bootp.

The Switch 1600M and 2400M can simultaneously support one out-of-band console session through the Console Port and one in-band telnet console session.

Terminal Configuration

To connect a console to the switch, configure the PC terminal emulator as a DEC VT-100 (ANSI) terminal or use a VT-100 terminal and configure it to operate with these settings. :

- any baud rate from 2400 to 115200 (the switch senses the speed)
- 8 data bits, 1 stop bit, no parity, XON/XOFF flow control
- For Windows Terminal program, also disable (uncheck) the "Use Function, Arrow, and Ctrl Keys for Windows" option.

If you want to operate the console using a different configuration, make sure you change with settings on both the terminal and on the switch. Change the switch settings first, then change the terminal settings, and reestablish the console session.

Direct Console Access

To connect a console to the switch, follow these steps:

1. Connect the PC or terminal to the switch's Console Port using the console cable included with the switch. (If your PC or terminal has a 25-pin serial connector, first attach a 9-pin to 25-pin "straight-through" adapter at one end of the console cable.)
2. Turn on the terminal or PC's power and, if using a PC, start the PC terminal program.
3. Press **Enter** two or three times and you will see the copyright page and the message "Press any key to continue". Press a key, and you will then see the switch console Main Menu.

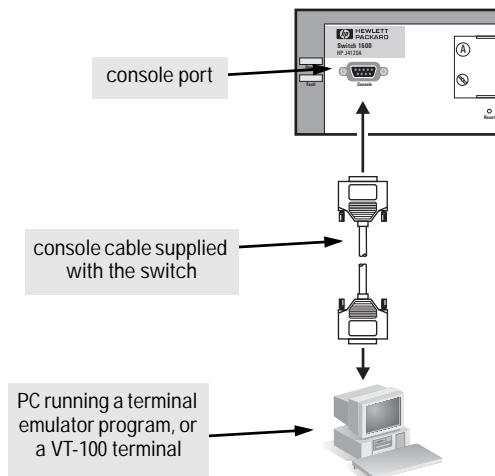

Telnet Console Access

To access the switch through a telnet session, follow these steps:

1. Make sure the switch is configured with an IP address and that the switch is reachable from the telnet workstation (for example by using a Ping command to the switch's IP address)
2. Start the telnet program and connect to the switch's IP address.
3. You will see the copyright page and the message "Press any key to continue". Press a key, and you will then see the switch console Main Menu.

If you want to continue with console management of the switch at this time, refer to the *Management and Configuration Guide* that came with your switch.

Hot Swapping the Switch Module (Switch 1600M only)

For the Switch 1600M, any of the HP ProCurve Switch Modules can be “hot swapped”, that is installed or replaced while the switch is powered on. The procedures differ slightly, though between adding a new module to the empty slot or replacing the module with the same type, and exchanging the module with a different type.

Adding or Replacing the Module

If a module has to be replaced with one of the same type, or you are expanding the switch capability by adding a module for the first time, the replaced or new module is immediately operational; there is no interruption to the switch operation.

Changing the Module Type

If you exchange the module with one of a different type though, for example a 100Base-FX module is installed in place of a 10/100Base-T module that was in the slot, the switch must be rebooted after the new module is installed so the switch processor can properly initialize and configure the new module type.

You can reboot the switch by any of these methods:

- select the Reset or Reboot option from the console, web browser interface, or HP TopTools for Hubs & Switches
- press the Reset button on the switch
- unplug and plug in the power cord (power cycle)

Until the switch is rebooted, the module will not operate, the Module Status LED will continue to flash, and all the LEDs on the module will stay on continuously.

Where to Go From Here

Your switch is now correctly installed and is able to send and receive data between end nodes, servers, and printers.

The Switch 1600M and 2400M are plug-and-communicate network devices requiring no configuration. If you wish to manage these switches from an SNMP-based network management station, you will need to configure the IP address on the switches; see the *Management and Configuration Guide* that came with your switch for information on how to use the switch console to configure the IP address.

Troubleshooting

This chapter describes how to troubleshoot your Switch 1600M and 2400M. Note that this document describes troubleshooting mostly from a hardware perspective. You can perform more in-depth troubleshooting using the software tools available with the switch, including the full-featured console interface, the built-in web browser interface, and HP TopTools for Hubs & Switches, the SNMP-based network management tool. See the Troubleshooting chapter of the *Management and Configuration Guide* included with your switch for more information.

This chapter describes the following:

- basic troubleshooting tips (page 3-2)
- diagnosing with the LEDs (page 3-4)
- Proactive Networking tools (page 3-7)
- hardware diagnostic tests (page 3-8)
- restoring the factory default configuration (page 3-10)
- HP Customer Support Services (page 3-11)

Basic Troubleshooting Tips

Most problems are caused by the following situations. Check for these items first when starting your troubleshooting:

- **Incorrect switch-to-switch or switch-to-hub connections.** If you have connected your switch to another switch or a hub by using twisted-pair cable from an RJ-45 MDI-X connector on your switch to the an MDI-X connector on the other switch or hub, you must use a **crossover cable**. If you have used a straight-through cable, the connection will not work. The LED for the port you are using will not come on when you connect the cable.

Most switch and hub ports are wired as MDI-X ports, so for these switch-to-switch or switch-to-hub connections use a crossover cable. LAN adapters in end nodes are normally wired as MDI ports as are some ports on hubs and switches. For connections from the switch to these MDI ports, use a **straight-through cable**. See appendix B, “Cables and Connectors” for pinouts and correct cable wiring for crossover and straight-through twisted-pair cables.

- **Faulty or loose cables.** Look for loose or obviously faulty connections. If they appear to be OK, make sure the connections are snug. If that does not correct the problem, try a different cable.
- **Non-standard cables.** Non-standard and miswired cables may cause numerous network collisions and other network problems, and can seriously impair network performance. Use a new correctly-wired cable or compare your cable to the cable in appendix B, “Cables and Connectors” for pinouts and correct cable wiring. A category 5 cable tester is a recommended tool for every 100Base-T network installation.
- **Improper Network Topologies.** It is important to make sure you have a valid network topology. Common topology faults include excessive cable length and excessive repeater delays between end nodes. If you have network problems after recent changes to the network, change back to the previous topology. If you no longer experience the problems, the new topology is probably at fault. Refer to the *Network Design Guide* for topology configuration guidelines. This guide can be found online at the HP World Wide Web site for networking products, http://www.hp.com/go/network_city under the Tech Library button.

In addition, you should make sure that your network topology contains no data path loops. Between any two end nodes, there should be only one active cabling path at any time. Data path loops will cause broadcast storms that will severely impact your network performance.

If you wish to build redundant paths between important nodes in your network to provide some fault tolerance, you should enable **Spanning Tree Protocol** support on the switch. This ensures that only one of the redundant paths is active at any time, thus avoiding data path loops. Spanning Tree can be enabled through the console, the web agent interface, or HP TopTools for Hubs & Switches.

The Switch 1600M also supports **Switch Meshing** which allows multiple data paths through a switched network to be active simultaneously for enhanced network bandwidth. See the *Management and Configuration Guide* that came with your switch for more information on Spanning Tree and on Switch Meshing.

Diagnosing with the LEDs

Tables 3-1 shows LED patterns on the switch and the switch modules that indicate problem conditions.

1. Check in the table for the LED pattern that you see on your switch.
2. Refer to the corresponding diagnostic tip on the next few pages.

Table 3-1. LED Error Indicators

LED Pattern Indicating Problems						Diagnostic Tips
Power	Fault	Self Test	Module Status	Fan Status	Port Link	
Off with power cord plugged in	*	*	*	*	*	1
On	Prolonged On	Prolonged On	*	*	*	2
On	Flashing [†]	Flashing [†]	*	*	*	3
On	Flashing [†]	Flashing [†]	Flashing [†]	*	*	4
On	Off	Off	Flashing [†]	*	*	5
On	Flashing [†]	Off	*	Flashing [†]	*	6
On	Off	Off	On	*	Off with cable connected	7
<p>* This LED is not important for the diagnosis. [†] The flashing behavior is an on/off cycle once every 1.6 seconds, approximately.</p>						

Diagnostic Tips:

Tip	Problem	Solution
❶	The switch is not plugged into an active AC power source, or the switch's power supply may have failed.	<ol style="list-style-type: none"> 1. Verify that the power cord is plugged into an active power source and to the switch. Make sure these connections are snug. 2. Try power cycling the switch by unplugging and plugging the power cord back in. 3. If the Power LED is still not on, verify that the AC power source works by plugging another device into the outlet. Or try plugging the switch into a different outlet or try a different power cord. <p>If the power source and power cord are OK and this condition persists, the switch power supply may have failed. Call your HP-authorized LAN dealer, or use the electronic support services from HP to get assistance. See the Customer Support/Warranty card for more information.</p>
❷	A switch hardware failure has occurred. All the LEDs will stay on indefinitely.	Try power cycling the switch. If the fault indication reoccurs, the switch may have failed. Call your HP-authorized LAN dealer, or use the electronic support services from HP to get assistance. See the Customer Support/Warranty card for more information.
❸	The switch has experienced a software failure during self test.	<ol style="list-style-type: none"> 1. Try resetting the switch by pressing the Reset button on the front of the switch, or by power cycling the switch. 2. If the fault indication reoccurs, attach a console to the switch (as indicated in chapter 2) and configure it to operate at 9600 baud. Then, reset the switch. Messages should appear on the console screen and in the console log identifying the error condition. You can view the console log at that point by selecting it from the console Main Menu. <p>If necessary to resolve the problem, contact your HP-authorized LAN dealer, or use the electronic support services from HP to get assistance. See the Customer Support/Warranty card for more information.</p>
❹	For the Switch 1600M: The module installed in the slot is not installed properly, has experienced a self test fault, or has become partly removed during switch operation.	<p>The module is tested whenever the switch is powered on, or reset (through the Reset button on the switch, or the Reboot or Reset options in the console or web browser interface), and when it is hot swapped (installed when the switch is powered on).</p> <p>Under this error condition, the following events also occur:</p> <ul style="list-style-type: none"> • All the LEDs on the module stay on until the error is resolved. • The switch software, including console and web browser access will not be operational for approximately one minute from the time the module gets into this condition. <p>Try rebooting the switch again. If that does not resolve the problem, try reinstalling the module. You can do this without having to power down the switch. When the module is reinstalled, it will be retested automatically. Make sure to screw in the retaining screws so that the module cannot be inadvertently pulled out by pulling on the network cables.</p> <p>If the fault indication reoccurs, the module may have failed. Remove the module from the switch and replace it with another module, or recover the slot with the cover plate. Call your HP-authorized LAN dealer, or use the electronic support services from HP to get assistance. See the Customer Support/Warranty card for more information.</p>

Tip	Problem	Solution
4	<p>For the Switch 2400M:</p> <p>The fixed module that has ports A1 through A8 on it has experienced a self test fault.</p>	<p>The module is tested whenever the switch is powered on, or reset (through the Reset button on the switch, or the Reboot or Reset options in the console or web browser interface). An error has been detected on the module during the self test.</p> <p>Try rebooting the switch again. If that does not resolve the problem, the switch may have failed. Call your HP-authorized LAN dealer, or use the electronic support services from HP to get assistance. See the Customer Support/Warranty card for more information.</p>
5	<p>A module was installed in the slot that is a different type than the previously installed module, and the switch has not yet been reset.</p>	<p>When you “hot swap” modules in the module slot in the Switch 1600M, if you install a different module type than the one that was previously installed in the slot, you must reset the switch. This allows the switch processor to properly initialize and configure the new module type. The flashing LED informs you that this change of module types has occurred. The module will not work properly until the switch is reset as indicated by all the module’s LEDs staying on until the switch is reset.</p> <p>You can reset the switch by any of these methods:</p> <ul style="list-style-type: none"> • pressing the Reset button on the switch • power cycling the switch • selecting the reset or reboot option from the console, web browser interface, or HP TopTools.
6	<p>One or more of the switch cooling fans may have failed.</p>	<p>Try disconnecting power from the switch and wait a few moments. Then reconnect the power to the switch and check the LEDs again. If the error indication reoccurs, one or more of the fans has failed. The switch has two fans and may continue to operate OK under this condition if the ambient temperature does not exceed normal room temperature, but for best operation, the switch should be replaced. Contact your HP-authorized LAN dealer, or use the electronic support services from HP to get assistance. See the Customer Support/Warranty card for more information.</p>
7	<p>The network connection is not working properly.</p>	<p>Try the following procedures:</p> <ul style="list-style-type: none"> • For the indicated port, verify that both ends of the cabling, at the switch and the connected device, are connected properly. • Verify the connected device and switch are both powered <i>on</i> and operating correctly. • Verify that you have used the correct cable type for the connection. <ul style="list-style-type: none"> - for twisted-pair connections, in general, for connecting an end node to the switch, use “straight-through” cable; for connecting MDI-X ports on hubs or other switches, use “crossover” cable. - for fiber-optic connections, verify that the transmit port on the switch is connected to the receive port on the connected device, and the switch receive port is connected to the transmit port on the connected device. • Verify that the port has not been disabled through a switch configuration change. <p>You can use the console interface, or, if you have configured an IP address on the switch, use the web browser interface, or HP TopTools for Hubs & Switches network management software to determine the state of the port and re-enable the port if necessary.</p> <ul style="list-style-type: none"> • If the other procedures don’t resolve the problem, try using a different port or a different cable.

Proactive Networking

The Switch 1600M and 2400M have built-in management capabilities that proactively help you manage your network including:

- finding and helping you fix the most common network error conditions (for example, faulty network cabling, and non-standard network topologies)
- informing you of the problem with clear, easy-to-understand messages
- recommending network configuration changes to enhance the performance of your network

The following interfaces provide tests, indicators, and an event log that can be used to monitor the switch and its network connections and to help you take advantage of these proactive networking features:

- HP TopTools for Hubs & Switches - an SNMP-based network management tool that is included with your switch.
- A graphical web browser interface that you can use to manage your switch from a PC running a supported web browser, for example Microsoft Internet Explorer, and Netscape Communicator.
- A full-featured easy-to-use console interface that you can access by merely connecting a standard terminal or PC running a terminal emulator to the switch's console port. The cable to make that connection is provided with your switch. The console interface is also accessible through a telnet connection.

See chapter 8, “Troubleshooting”, in the *Management and Configuration Guide* that came with your switch for more information on using these software tools to diagnose and manage your switch.

Hardware Diagnostic Tests

Testing the Switch by Resetting It

If you believe that the switch is not operating correctly, you can reset the switch to test its circuitry and operating code. To reset a switch, either:

- Unplug and plug in the power cord (power cycling)
- Press the reset button on the front of the switch

Power cycling the switch and pressing the Reset button both cause the switch to perform its power-on self-test, which almost always will resolve any temporary operational problems. These reset processes also cause any network traffic counters to be reset to zero, and cause the System Up Time timer to reset to zero. None of the reset procedures cause any changes to the switch configuration.

Checking the Switch LEDs

The self-test passes if the Fault and Self Test LEDs on the front of the switch go off after approximately 30 to 45 seconds. (For the Switch 1600M, the duration depends on whether a module is installed in the switch.) If these LEDs stay on longer than 60 seconds or begin flashing, the switch may have to be replaced.

See “Diagnosing With the LEDs” on page 3-4 for information on interpreting the LED patterns.

Checking Console Messages

Useful diagnostic messages may be displayed on the console screen when the switch is reset. As described in chapter 2 under step 7, “Connect a Console to the Switch”, connect a PC running a VT-100 terminal emulator program or a standard VT-100 terminal to the switch’s Console Port and configure it to run at 9600 baud, and with the other terminal communication settings shown on page 2-13. Then, when you reset the switch, note the messages that are displayed.

Testing Twisted-Pair Cabling

If you think the cable should work but still isn't working, it may not be compatible with the IEEE 802.3 Type 10Base-T or 100Base-T standards. The twisted-pair cables attached to the Switch 1600M and 2400M must be compatible with these standards. To verify that your cable is compatible with these standards, use a qualified cable test device.

HP also offers a wire testing service. Contact your HP-authorized LAN dealer or your local HP sales office for more information.

Note

Make sure that you are using the correct cabling type for each connection. The switch UTP ports are all wired as MDI-X. For connecting end nodes and other MDI-type devices, use "straight-through" cable. For connecting hubs, other switches, and other MDI-X devices, use "crossover" cable. See appendix B, "Cables and Connectors" for the pinouts for these cables.

Testing Switch-to-Device Network Communications

You can perform the following communication tests to verify that the network is operating correctly between the switch and any connected device that can respond correctly to the communication test.

- Link Test – a physical layer test that sends IEEE 802.2 test packets to any device identified by its MAC address
- Ping Test – a network layer test used on IP networks that sends test packets to any device identified by its IP address

These tests can be performed through the switch console interface from a terminal connected to the switch or through a telnet connection, or from the switch's web browser interface. See the *Management and Configuration Guide* that came with your switch for more information.

These tests can also be performed from an SNMP network management station running a program that can manage the switch, for example, HP TopTools for Hubs & Switches.

Testing End-to-End Network Communications

Both the switch and the cabling can be tested by running an end-to-end communications test -- a test that sends known data from one network device to another through the switch. For example, if you have two PCs on the network that have LAN adapters between which you can run a link-level test or Ping test through the switch, you can use this test to verify that the entire communication path between the two PCs is functioning correctly. See your LAN adapter documentation for more information on running the a link test or Ping test.

Restoring the Factory Default Configuration

As part of your troubleshooting process, it may become necessary to return the switch configuration to the factory default settings. This process momentarily interrupts the switch operation, clears any passwords, clears the console event log, resets the network counters to zero, performs a complete self test, and reboots the switch into its factory default configuration including deleting an IP address.

To execute the factory default reset, perform these steps:

1. Using pointed objects, simultaneously press both the Reset and Clear buttons on the front of the switch.
2. Continue to press the Clear button while releasing the Reset button.
3. When the Self Test LED begins to flash, release the Clear button.

HP Customer Support Services

If you are still having trouble with your switch, Hewlett-Packard offers support 24 hours a day, seven days a week through the use of a number of automated electronic services. See the Customer Support/Warranty booklet that came with your switch for information on how to use these services to get technical support. The HP networking products World Wide Web site, http://www.hp.com/go/network_city also provides up-to-date support information.

Additionally, your HP-authorized network reseller can also provide you with assistance, both with services that they offer and with services offered by HP.

Specifications

Except where noted, the following specifications apply to both the Switch 1600M and the Switch 2400M.

Physical

Width:	44.2 cm (17.4 in)
Depth:	33.5 cm (13.2 in)
Height:	6.6 cm (2.6 in)
Weight:	
• Switch 1600M	4.5 kg (9.9 lbs)
• Switch 2400M	4.7 kg (10.4 lbs)

Electrical

The Switch 1600M and 2400M automatically adjusts to any voltage between 100-127 and 200-240 volts and either 50 or 60 Hz.

AC voltage:	100–127 volts	200–240 volts
Maximum current:	1.0 A	0.6 A
Frequency range:	50/60 Hz	50/60 Hz

Environmental

	Operating	Non-Operating
Temperature:	0°C to 55°C (32°F to 131°F)	-40°C to 70°C (-40°F to 158°F)
Relative humidity: (non-condensing)	15% to 95% at 40°C (104°F)	15% to 90% at 65°C (149°F)
Maximum altitude:	4.6 Km (15,000 ft)	4.6 Km (15,000 ft)

Acoustic

Geraeuschemission LwA=54 dB am fiktiven Arbeitsplatz nach DIN 45635 T.19

Connectors

- The 10/100 Mbps RJ-45 twisted-pair ports are compatible with the IEEE 802.3u 100Base-T standard.
- The 100 Mbps SC fiber-optic are compatible with the IEEE 802.3u 100Base-FX standard.
- The 10 Mbps ST fiber-optic ports are compatible with the IEEE 802.3 Type 10Base-FL standard.
- The 1000 Mbps SC fiber-optic ports are compatible with the IEEE 802.3z Gigabit-SX standard.

Safety

- EN60950 IEC 950
- CSA 950
- NOM-019-SCFI-1994
- UL 1950

Cables and Connectors

This appendix includes minimum pin-out information and specifications for cables that should be used with the Switch 1600M and 2400M.

Note

Incorrectly wired cabling is the most common cause of problems for LAN communications. HP recommends that you work with a qualified LAN cable installer for assistance with your cabling requirements.

Twisted-Pair Cable/Connector Pin-Outs

The RJ-45 connectors on the 10/100Base-TX ports on the Switch 1600M and 2400M are wired as MDI-X ports. The type of twisted-pair cable you connect to these ports (either “straight through” or “crossover”) depends on the type of device at the other end of the cable.

***The rule is**, when connecting same-type ports together (for example MDI-X-to-MDI-X), use crossover cable; when connecting opposite-type ports together (for example MDI-X-to-MDI), use straight-through cable.*

These additional rules apply:

- All twisted-pair wires used must be twisted through the entire length of the cable. The wiring sequence must conform to AT&T 258A (not USOC). See “Twisted-Pair Cable Pin Assignments” later in this appendix for a listing of the signals used on each pin.
- For 10 Mbps connections to the ports, you can use Category 3, 4, or 5 unshielded twisted-pair cable, as supported by the IEEE 802.3 Type 10Base-T standard.
- For 100 Mbps connections to the ports, use 100-ohm Category 5 UTP or STP cable only, as supported by the IEEE 802.3u Type 100Base-TX standard.

Twisted-Pair Cable for Switch (MDI-X) to Computer (MDI) Network Connection

To connect PCs or other MDI network devices to these ports, use a “straight-through” cable.

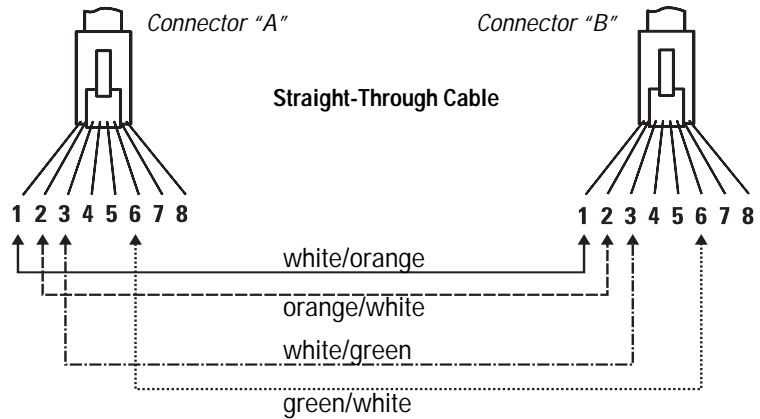

Note

Pins 1 and 2 on connector "A" *must* be wired as a twisted pair to pins 1 and 2 on connector "B".

Pins 3 and 6 on connector "A" *must* be wired as a twisted pair to pins 3 and 6 on connector "B".

Pins 4, 5, 7, and 8 are not used in this application, although they may be wired in the cable.

Twisted-Pair Cable for Switch (MDI-X) to Hub or Switch (MDI-X) Network Connection

To connect hubs or switches or other MDI-X network devices to these ports, use a “crossover” cable.

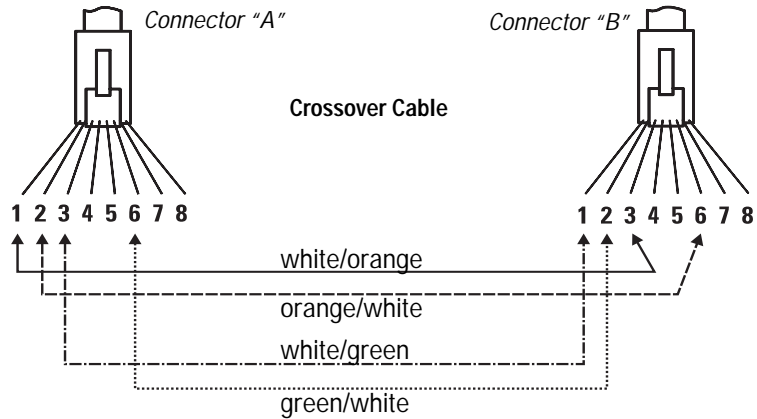

Note

Pins 1 and 2 on connector “A” *must* be wired as a twisted pair to pins 3 and 6 on connector “B”.

Pins 3 and 6 on connector “A” *must* be wired as a twisted pair to pins 1 and 2 on connector “B”.

Pins 4, 5, 7, and 8 are not used in this application, although they may be wired in the cable.

Twisted-Pair Cable Pin Assignments

Twisted-Pair Straight-Through Cable

Switch End (MDI-X)		Computer, Transceiver, or Other MDI Port End		
Signal	Pins	Pins	Signal	
receive +	1	←	1	transmit +
receive -	2	←	2	transmit -
transmit +	3	→	3	receive +
transmit -	6	→	6	receive -

Twisted-Pair Cross-Over Cable

Switch End (MDI-X)		Hub or Switch Port, or Other MDI-X Port End		
Signal	Pins	Pins	Signal	
receive +	1	←	6	transmit -
receive -	2	←	3	transmit +
transmit +	3	→	2	receive -
transmit -	6	→	1	receive +

Fiber-Optic Cables

10Base-FL Ports

Fiber-optic cables connected to the ports on the 10Base-FL Switch Module that can be installed in the Switch 1600M must be 850 nm wavelength, multimode cable conforming to the ISO/IEC 793-2 type B1, and ITU-T G.652 standards, and the cables must have ST-type connectors.

100Base-FX Ports

Fiber-optic cables connected to the ports on the 100Base-FX Switch Module that can be installed in the Switch 1600M must be 1300 nm wavelength, multimode cable conforming to the ISO/IEC 793-2 type B1, and ITU-T G.652 standards, and the cables must have SC-type connectors.

Gigabit-SX Ports

Fiber-optic cables connected to the port on the Gigabit-SX Switch Module that can be installed in the Switch 1600M must be 850 nm wavelength, multimode cable that are fitted with SC-type connectors.

Safety and EMC Regulatory Statements

Safety Information



Documentation reference symbol. If the product is marked with this symbol, refer to the product documentation to get more information about the product.

WARNING

A WARNING in the manual denotes a hazard that can cause injury or death.

CAUTION

A CAUTION in the manual denotes a hazard that can damage equipment.

Do not proceed beyond a WARNING or CAUTION notice until you have understood the hazardous conditions and have taken appropriate steps.

Grounding

These are safety class I products and have protective earthing terminals. There must be an uninterruptible safety earth ground from the main power source to the product's input wiring terminals, power cord, or supplied power cord set. Whenever it is likely that the protection has been impaired, disconnect the power cord until the ground has been restored.

For LAN cable grounding:

- If your LAN covers an area served by more than one power distribution system, be sure their safety grounds are securely interconnected.
- LAN cables may occasionally be subject to hazardous transient voltages (such as lightning or disturbances in the electrical utilities power grid). Handle exposed metal components of the network with caution.

Servicing

There are no user-serviceable parts inside these products. Any servicing, adjustment, maintenance, or repair must be performed only by service-trained personnel.

These products do not have a power switch; they are powered on when the power cord is plugged in.

Informations concernant la sécurité



Symbole de référence à la documentation. Si le produit est marqué de ce symbole, reportez-vous à la documentation du produit afin d'obtenir des informations plus détaillées.

WARNING

Dans la documentation, un WARNING indique un danger susceptible d'entraîner des dommages corporels ou la mort.

CAUTION

Un texte de mise en garde intitulé CAUTION indique un danger susceptible de causer des dommages à l'équipement.

Ne continuez pas au-delà d'une rubrique WARNING ou CAUTION avant d'avoir bien compris les conditions présentant un danger et pris les mesures appropriées.

Cet appareil est un produit de classe I et possède une borne de mise à la terre. La source d'alimentation principale doit être munie d'une prise de terre de sécurité installée aux bornes du câblage d'entrée, sur le cordon d'alimentation ou le cordon de raccordement fourni avec le produit. Lorsque cette protection semble avoir été endommagée, débrancher le cordon d'alimentation jusqu'à ce que la mise à la terre ait été réparée.

Mise à la terre du câble de réseau local:

- si votre réseau local s'étend sur une zone desservie par plus d'un système de distribution de puissance, assurez-vous que les prises de terre de sécurité soient convenablement interconnectées.
- Les câbles de réseaux locaux peuvent occasionnellement être soumis à des surtensions transitoires dangereuses (telles que la foudre ou des perturbations dans le réseau d'alimentation public). Manipulez les composants métalliques du réseau avec précautions.

Aucune pièce contenue à l'intérieur de ce produit ne peut être réparée par l'utilisateur. Tout dépannage, réglage, entretien ou réparation devra être confié exclusivement à un personnel qualifié.

Cet appareil ne comporte pas de commutateur principal ; la mise sous tension est effectuée par branchement du cordon d'alimentation.

Hinweise zur Sicherheit



WARNING

Symbol für Dokumentationsverweis. Wenn das Produkt mit diesem Symbol markiert ist, schlagen Sie bitte in der Produktdokumentation nach, um mehr Informationen über das Produkt zu erhalten.

CAUTION

Symbol für Dokumentationsverweis. Wenn das Produkt mit diesem Symbol markiert ist, schlagen Sie bitte in der Produktdokumentation nach, um mehr Informationen über das Produkt zu erhalten.

Fahren Sie nach dem Hinweis WARNING oder CAUTION erst fort, nachdem Sie den Gefahrenzustand verstanden und die entsprechenden Maßnahmen ergriffen haben.

Dies ist ein Gerät der Sicherheitsklasse I und verfügt über einen schützenden Erdungsterminal. Der Betrieb des Geräts erfordert eine ununterbrochene Sicherheitserdung von der Hauptstromquelle zu den Geräteingabeterminals, den Netzkabeln oder dem mit Strom belieferten Netzkabelsatz voraus. Sobald Grund zur Annahme besteht, daß der Schutz beeinträchtigt worden ist, das Netzkabel aus der Wandsteckdose herausziehen, bis die Erdung wiederhergestellt ist.

Für LAN-Kabelerdung:

- Wenn Ihr LAN ein Gebiet umfaßt, das von mehr als einem Stromverteilungssystem beliefert wird, müssen Sie sich vergewissern, daß die Sicherheitserdungen fest untereinander verbunden sind.
- LAN-Kabel können gelegentlich gefährlichen Übergangsspannungen ausgesetzt werden (beispielsweise durch Blitz oder Störungen in dem Starkstromnetz des Elektrizitätswerks). Bei der Handhabung exponierter Metallbestandteile des Netzwerkes Vorsicht walten lassen.

Dieses Gerät enthält innen keine durch den Benutzer zu wartenden Teile. Wartungs-, Anpassungs-, Instandhaltungs- oder Reparaturarbeiten dürfen nur von geschultem Bedienungspersonal durchgeführt werden.

Dieses Gerät hat keinen Netzschalter; es wird beim Anschließen des Netzkabels eingeschaltet.

Considerazioni sulla sicurezza



Simbolo di riferimento alla documentazione. Se il prodotto è contrassegnato da questo simbolo, fare riferimento alla documentazione sul prodotto per ulteriori informazioni su di esso.

WARNING

La dicitura WARNINGdenota un pericolo che può causare lesioni o morte.

CAUTION

La dicituraCAUTION denota un pericolo che può danneggiare le attrezzature.

Non procedere oltre un avviso di WARNING o di CAUTIONprima di aver compreso le condizioni di rischio e aver provveduto alle misure del caso.

Questo prodotto è omologato nella classe di sicurezza I ed ha un terminale protettivo di collegamento a terra. Dev'essere installato un collegamento a terra di sicurezza, non interrompibile che vada dalla fonte d'alimentazione principale ai terminali d'entrata, al cavo d'alimentazione oppure al set cavo d'alimentazione fornito con il prodotto. Ogniquilvolta vi sia probabilità di danneggiamento della protezione, disinserite il cavo d'alimentazione fino a quando il collegaento a terra non sia stato ripristinato.

Per la messa a terra dei cavi LAN:

- se la vostra LAN copre un'area servita da più di un sistema di distribuzione elettrica, accertatevi che i collegamenti a terra di sicurezza siano ben collegati fra loro;
- i cavi LAN possono occasionalmente andare soggetti a pericolose tensioni transitorie (ad esempio, provocate da lampi o disturbi nella griglia d'alimentazione della società elettrica); siate cauti nel toccare parti esposte in metallo della rete.

Nessun componente di questo prodotto può essere riparato dall'utente. Qualsiasi lavoro di riparazione, messa a punto, manutenzione o assistenza va effettuato esclusivamente da personale specializzato.

Questo apparato non possiede un commutatore principale; si mette scotto tensione all'inserirsi il cavo d'alimentazione.

Consideraciones sobre seguridad



Símbolo de referencia a la documentación. Si el producto va marcado con este símbolo, consultar la documentación del producto a fin de obtener mayor información sobre el producto.

WARNING

Una WARNING en la documentación señala un riesgo que podría resultar en lesiones o la muerte.

CAUTION

Una CAUTION en la documentación señala un riesgo que podría resultar en averías al equipo.

No proseguir después de un símbolo de WARNING o CAUTION hasta no haber entendido las condiciones peligrosas y haber tomado las medidas apropiadas.

Este aparato se enmarca dentro de la clase I de seguridad y se encuentra protegido por una borna de puesta a tierra. Es preciso que exista una puesta a tierra continua desde la toma de alimentación eléctrica hasta las bornas de los cables de entrada del aparato, el cable de alimentación o el juego de cable de alimentación suministrado. Si existe la probabilidad de que la protección a tierra haya sufrido desperfectos, desenchufar el cable de alimentación hasta haberse subsanado el problema.

Puesta a tierra del cable de la red local (LAN):

- Si la LAN abarca un área cuyo suministro eléctrico proviene de más de una red de distribución de electricidad, cerciorarse de que las puestas a tierra estén conectadas entre sí de modo seguro.
- Es posible que los cables de la LAN se vean sometidos de vez en cuando a voltajes momentáneos que entrañen peligro (rayos o alteraciones en la red de energía eléctrica). Manejar con precaución los componentes de metal de la LAN que estén al descubierto.

Este aparato no contiene pieza alguna susceptible de reparación por parte del usuario. Todas las reparaciones, ajustes o servicio de mantenimiento debe realizarlos solamente el técnico.

Este producto no tiene interruptor de potencia; se activa cuando se enchufa el cable de alimentación.

Safety Information (Japan)

安全性の考慮

安全記号



マニュアル参照記号。製品にこの記号がついている場合はマニュアルを参照し、注意事項等をご確認ください。

WARNING マニュアル中の「WARNING」は人身事故の原因となる危険を示します。

CAUTION マニュアル中の「CAUTION」は装置破損の原因となる危険を示します。

「WARNING」や「CAUTION」の項は飛ばさないで必ずお読みください。危険性に関する記載事項をよく読み、正しい手順に従った上で次の事項に進んでください。

これは安全性クラス I の製品で保護用接地端子を備えています。主電源から製品の入力配線端子、電源コード、または添付の電源コード・セットまでの間、切れ目のない安全接地が存在することが必要です。もしこの保護回路が損なわれたことが推測されるときは、接地が修復されるまで電源コードを外しておいてください。

LAN ケーブルの接地に関して:

- もし貴社の LAN が複数の配電システムにより電力を受けている領域をカバーしている場合には、それらのシステムの安全接地が確実に相互に結合されていることを確認してください。
- LAN ケーブルは時として危険な過度電圧（例えば雷や、配電設備の電力網での障害）にさらされることがあります。露出した金属部分の取扱いには十分な注意をはらってください。

本製品の内部にはユーザーが修理できる部品はありません。サービス、調整、保守および修理はサービス訓練を受けた専門家におまかせください。

本製品には電源スイッチがありません。電源コードを接続したとき電源入となります。

Safety Information (China)

HP 网络产品使用安全手册

使用须知

欢迎使用惠普网络产品，为了您及仪器的安全，请注意如下事项

1. 仪器要和地线相接。要使用有正确接地插头的电源线，使用中国国家规定的220V电源。
2. 避免高湿度和灰尘多的地方，否则易引起仪器内部部件的损坏。
3. 避免接近高温，避免接近直接热源，如直射太阳光、暖气等其它发热体。
4. 不得有异物或液体落入机内，以免部件短路。
5. 不要将强磁体放置于仪器附近。

警告

为了防止火灾或触电事故，请不要将该机放置于淋雨或潮湿处。

安装

安装辅助管理模块请参看安装指南。

保修及技术支持

如果您按以上步骤正确使用但遇到了问题，或想了解其它产品性能，请按以下方式与我们联系。

如果是硬件故障：

1. 与售出单位或当地维修机构联系。
2. 惠普维修中心：

北京市海淀区知春路56号 中航科技大厦

邮政编码：100086

电话：010-62623888 转 6101

如果是软件问题：

1. 惠普技术支持中心热线电话：010-65053888 转 5858
2. 传真自动回复系统：010-65055280

EMC Regulatory Statements

U.S.A.

FCC Class A

This equipment has been tested and found to comply with the limits for a Class A digital device, pursuant to Part 15 of the FCC Rules. These limits are designed to provide reasonable protection against interference when the equipment is operated in a commercial environment. This equipment generates, uses, and can radiate radio frequency energy and, if not installed and used in accordance with the instruction manual, may cause interference to radio communications. Operation of this equipment in a residential area may cause interference in which case the user will be required to correct the interference at his own expense.

Canada

This product complies with Class A Canadian EMC requirements.

Australia/New Zealand



This product complies with Australia/New Zealand EMC Class A requirements.

Japan

VCCI Class A

この装置は、情報処理装置等電波障害自主規制協議会（VCCI）の基準に基づくクラスA情報技術装置です。この装置を家庭環境で使用すると電波妨害を引き起こすことがあります。この場合には使用者が適切な対策を講ずるよう要求されることがあります。

Korea

사용자 안내문 : A 급기기

이기는 업무용으로 전자파 적합등록을 받은 기기 이오니, 판매자 또는 사용자는 이점을 주의하시기 바라며, 만약 잘못 구입하셨을 때에는 구입한 곳에서 비업무용으로 교환하시기 바랍니다.

Taiwan

警告使用者：這是甲類的資訊產品，在居住的環境中使用時，可能會造成射頻干擾，在這種情況下，使用者會被要求採取某些適當的對策。

European Community

DECLARATION OF CONFORMITY

according to ISO/IEC Guide 22 and EN45014

Manufacturer's Name: Hewlett-Packard Company

Manufacturer's Address: 8000 Foothills Blvd.
Roseville, CA 95747-5502
U.S.A.

declares that the product:

Product Name: HP ProCurve Switch 1600M
HP ProCurve Switch 2400M

Model Number: HP J4120A
HP J4122A

Accessories: HP J4111A, HP J4112A, HP J4113A,
HP J4118A

conforms to the following Product Specifications:

Safety: EN60950 (1992)+A1,A2 / IEC 950:1991+A1,A2

EMC: EN 55022 (1994) / CISPR-22 (1993) class A
EN50082-1 (1992)
prEN 55024-2 (1992) / IEC 801-2 (1991) 4 kV CD, 8 kV AD
prEN 55024-3 (1991) / IEC 801-3 (1984), 3 V/m
prEN 55024-4 (1992) / IEC 801-4 (1988): 1 kV-(power line)
0.5 kV-(signal line)

Supplementary Information:

The product herewith complies with the requirements of the Low Voltage Directive 73/23/EEC and the EMC Directive 89/336/EEC and carries the CE marking accordingly. LEDs in this product(s) are Class-1 in accordance with EN60825-1:1994.

Tested with Hewlett-Packard Co. products only.

Roseville, June 16, 1998



Karen Dorchak, Quality Manager

European Contact: Your local Hewlett-Packard Sales and Service Office or Hewlett-Packard GmbH, Department TRE, Herrenberger Strasse 130, D-71034 Böblingen (FAX:+49-7031-14-3143).

Index

Numerics

- 10/100Base-TX ports
 - location on switch ... 1-2
- 100 LED ... 1-3
- 100Base-FX
 - connections, length limitations ... 2-4
 - ports, cables used with ... 2-4, B-5
- 100Base-TX
 - connections, length limitations ... 2-4
 - ports, cables used with ... 2-4
- 10Base-FL
 - connections, length limitations ... 2-4
 - ports, cables used with ... 2-4, B-5
- 10Base-T
 - connections, length limitations ... 2-4
 - ports, cables used with ... 2-4

A

- Act LED ... 1-3
- address learning ... 1-8
- address table
 - automatic address learning ... 1-8
 - filtering out traffic ... 1-8
 - flooding traffic ... 1-8
 - forwarding traffic ... 1-8
 - moves and changes ... 1-8
 - operation ... 1-8

B

- back of switch
 - description ... 1-6
 - power connector ... 1-6
- bandwidth, how switch enhances ... 1-9
- basic troubleshooting tips ... 3-2
- Bootp
 - for in-band access ... 2-13
- buttons
 - Clear button ... 1-5
 - Mode Select button ... 1-4
 - Reset button ... 1-5

C

- cabinet
 - mounting the switch in ... 2-8
- cables
 - 100Base-FX
 - connections ... 2-4
 - fiber-optic cable specifications ... B-5
 - 100Base-TX connections ... 2-4
 - 10Base-FL
 - connections ... 2-4
 - fiber-optic cable specifications ... B-5
 - 10Base-T connections ... 2-4
 - connecting cables to switch ports ... 2-12
 - effects of non-standard cables ... 3-2
 - fiber-optic, specifications ... B-5
 - Gigabit-SX
 - connections ... 2-4
 - fiber-optic cable specifications ... B-5
 - incorrect network connections ... 3-2
 - infrastructure requirements ... 2-4
 - length limitations ... 2-4
 - required types ... 2-4
 - serial, for direct console connection ... 2-14
 - twisted-pair connector pin-outs ... B-1
- cables, twisted pair
 - category 3, 4, 5 ... B-1
 - cross-over cable pin-out ... B-4
 - MDI-X to MDI connections ... B-2
 - MDI-X to MDI-X connections ... B-3
 - pin-outs ... B-4
 - straight-through cable pin-out ... B-4
 - switch-to-computer connection ... B-2
 - switch-to-switch or hub connection ... B-3
- cabling infrastructure ... 2-4
- Clear button
 - deleting passwords ... 1-5
 - description ... 1-5
 - location on switch ... 1-2, 1-5
 - restoring factory default configuration ... 1-5, 3-10
- configuration
 - restoring factory defaults ... 1-5, 3-10
- connecting the switch to a power source ... 2-11

connector specifications ... A-2
console
 checking messages during
 troubleshooting ... 3-8
 displaying the Main menu ... 2-14
 features ... 2-13
 how to connect in-band ... 2-13
 how to connect out-of-band ... 2-13
 serial cable connection ... 2-14
 telnet access ... 2-14
 terminal configuration ... 2-13
console port
 description ... 1-5
 location on switch ... 1-2, 1-5
cross-over cable
 pin-out ... B-4

D

deleting passwords ... 1-5
description
 back of switch ... 1-6
 front of switch ... 1-2
 LEDs ... 1-3
 switch ... 1-1
DHCP
 for in-band access ... 2-13
diagnostic tests ... 3-8
 checking the console messages ... 3-8
 checking the LEDs ... 3-8
 end-to-end connectivity ... 3-10
 testing the switch only ... 3-8
 testing twisted-pair cabling ... 3-9

E

electrical specifications, switch ... A-1
EMC regulatory statements ... C-8
environmental specifications, switch ... A-1

F

factory default configuration, restoring ... 1-5, 3-10
Fan Status LED ... 1-3
Fault LED ... 1-3
 behavior during self test ... 2-7
 behaviors ... 1-3
 flashing definition ... 1-3
 location on switch ... 1-2
 showing error conditions ... 3-4
Fdx LED ... 1-3
features
 console ... 2-13
 Switch 1600M and 2400M ... 1-7
fiber-optic cables ... B-5
 100Base-FX ... B-5
 10Base-FL ... B-5
 Gigabit-SX ... B-5
filtering out traffic ... 1-8
flashing LEDs
 error indications ... 3-4
flooding traffic ... 1-8
forwarding traffic ... 1-8
front of switch
 10/100Base-TX ports ... 1-2
 Clear button ... 1-5
 console port ... 1-5
 description ... 1-2
 LEDs ... 1-3
 Mode Select button and LEDs ... 1-4
 network ports ... 1-2
 Reset button ... 1-5
 slot for switch port modules ... 1-2

G

Gigabit-SX
 connections, length limitations ... 2-4
 ports, cables used with ... 2-4, B-5

H

horizontal surface, mounting switch on ... 2-10
hot swapping
 resetting the switch for new module type ... 2-15
 switch modules ... 2-15

I

- in-band console access
 - types of ... 2-13
- included parts ... 2-1
- incorrect network connections ... 3-2
- installation
 - connecting the switch to a power source ... 2-11
 - horizontal surface mounting ... 2-10
 - network cable requirements ... 2-4
 - optional modules ... 2-5
 - precautions ... 2-3
 - rack or cabinet mounting ... 2-8
 - site preparation ... 2-4
 - summary of steps ... 2-2
 - Switch 1600M and 2400M ... 2-1
 - wall mounting ... 2-11

L

- LEDs
 - 10/100Base-TX ports ... 1-4
 - 100 ... 1-3
 - Act ... 1-3
 - behavior during self test ... 2-7
 - checking during troubleshooting ... 3-8
 - descriptions of ... 1-3
 - error indications ... 3-4
 - Fan Status ... 1-3
 - Fault ... 1-3
 - behavior during self test ... 2-7
 - showing error conditions ... 3-4
 - Fdx ... 1-3
 - flashing definition ... 1-3
 - Link ... 1-4
 - location on switch ... 1-2
 - Mode
 - description ... 1-4
 - selecting the display ... 1-4
 - mode select indicators ... 1-3
 - Module Status ... 1-3
 - on switch ... 1-3
 - on switch modules ... 1-4
 - Power ... 1-3
 - behavior during self test ... 2-7
 - Self Test ... 1-3
 - behavior during self test ... 2-7

- length limitations
 - 100Base-FX connections ... 2-4
 - 100Base-TX connections ... 2-4
 - 10Base-FL connections ... 2-4
 - 10Base-T connections ... 2-4
 - Gigabit-SX connections ... 2-4
- Link LEDs ... 1-4
- link test ... 3-9

M

- Main menu, console
 - displaying ... 2-14
- MDI-X to MDI network cable ... B-2
- MDI-X to MDI-X network cable ... B-3
- Mode LEDs
 - description ... 1-4
 - selecting the display ... 1-4
- Mode Select
 - button ... 1-4
 - indicator LEDs ... 1-3–1-4
- Module Status LED ... 1-3
- modules
 - switch modules
 - hot swapping ... 2-15
 - installing ... 2-5
 - LEDs ... 1-4
- mounting the switch
 - in a rack or cabinet ... 2-8
 - precautions ... 2-3
 - on a horizontal surface ... 2-10
 - on a wall ... 2-11
 - precautions ... 2-11
- moves and changes
 - effect on address table ... 1-8

N

- network cables
 - 100Base-FX connections ... 2-4
 - 100Base-TX connections ... 2-4
 - 10Base-FL connections ... 2-4
 - 10Base-T connections ... 2-4
 - fiber-optic, specifications ... B-5
 - Gigabit-SX connections ... 2-4
 - incorrect connections ... 3-2
 - required types ... 2-4
 - twisted-pair connector pin-outs ... B-1

network devices
 connecting to the switch ... 2-12
network ports
 connecting to ... 2-12
 LEDs for ... 1-4
 location on switch ... 1-2
 standards compliance ... A-2
 types of ... 1-2, 2-4
non-standard network cables, effects ... 3-2

O

out-of-band console access ... 2-14

P

parts, included with the switch ... 2-1
passwords, deleting ... 1-5
physical specifications, switch ... A-1
Ping test ... 3-9
pin-outs
 twisted-pair cables ... B-1
port LEDs
 Link ... 1-4
 Mode ... 1-4
ports
 10/100Base-TX, location on switch ... 1-2
 connecting to ... 2-12
 console ... 1-5, 2-13
 network connections ... 2-12
power connector ... 1-6
Power LED ... 1-3
 behavior during self test ... 2-7
 behaviors ... 1-3
 location on switch ... 1-2
power source
 connecting the switch to ... 2-11
precautions
 mounting the switch ... 2-3
 power requirements ... 2-3
preparing the installation site ... 2-4
Proactive Network tools
 diagnostics with ... 3-7

R

rack
 mounting precautions ... 2-3
 mounting the switch in ... 2-8
rebooting the switch
 to initialize new module type ... 2-5
regulatory statements ... C-8
Reset button
 description ... 1-5
 location on switch ... 1-2, 1-5
 restoring factory default configuration ... 3-10
resetting the switch
 factory default reset ... 3-10
 for module hot swap ... 2-15
 location of Reset button ... 1-5
 troubleshooting procedure ... 3-8

S

safety and regulatory statements ... C-1
safety specifications ... A-2
selecting the Mode LED display ... 1-4
self test
 Fault LED behavior ... 2-7
 LED behavior during ... 2-7
 Power LED behavior ... 2-7
Self Test LED ... 1-3
 behavior during factory default reset ... 3-10
 behavior during self test ... 2-7
serial cable
 for direct console connection ... 2-14
slot for switch module
 location on switch ... 1-2
specifications
 connectors ... A-2
 electrical ... A-1
 environmental ... A-1
 physical ... A-1
 safety ... A-2
straight-through cable
 pin-out ... B-4
summary
 of cables used with the switch ... 2-4
 of switch installation ... 2-2

- switch
 - connecting to a power source ... 2-11
 - description ... 1-1
 - electrical specifications ... A-1
 - environmental specifications ... A-1
 - features ... 1-7
 - front panel description ... 1-2
 - included parts ... 2-1
 - LED descriptions ... 1-3
 - mounting in a rack or cabinet ... 2-8
 - mounting on a wall ... 2-11
 - mounting on horizontal surface ... 2-10
 - operation ... 1-8
 - physical specifications ... A-1
- switch modules
 - booting the switch to initialize new module
 - type ... 2-5
 - hot swapping ... 2-15
 - installing ... 2-5
 - LEDs description ... 1-4
 - slot, location on switch ... 1-2
- switch operation
 - address table ... 1-8
 - description ... 1-8
 - effect of VLANs ... 1-9
 - filtering out traffic ... 1-8
 - flooding traffic ... 1-8
 - forwarding traffic ... 1-8
 - network moves and changes ... 1-8
 - simultaneous network communications ... 1-9
 - verifying after installation ... 2-6

T

- telnet access to the console ... 2-14
- terminal configuration ... 2-13
- testing
 - checking the console messages ... 3-8
 - checking the LEDs ... 3-8
 - diagnostic tests ... 3-8
 - end-to-end communications ... 3-10
 - link test ... 3-9
 - Ping test ... 3-9
 - switch operation ... 3-8
 - switch-to-device communications ... 3-9
 - twisted-pair cabling ... 3-9
- tips for troubleshooting ... 3-2

- topologies
 - effects of improper topology ... 3-2
- troubleshooting ... 3-1
 - basic tips ... 3-2
 - checking the console messages ... 3-8
 - checking the LEDs ... 3-8
 - common network problems ... 3-2
 - diagnostic tests ... 3-8
 - effects of improper topology ... 3-2
 - effects of non-standard cables ... 3-2
 - incorrect network connections ... 3-2
 - link test ... 3-9
 - Ping test ... 3-9
 - Proactive Network tools ... 3-7
 - restoring factory default configuration ... 3-10
 - testing connections to other devices ... 3-9
 - testing end-to-end communications ... 3-10
 - testing the switch ... 3-8
 - testing the twisted-pair cables ... 3-9
- twisted-pair cable
 - cross-over cable pin-out ... B-4
 - pin-outs ... B-1, B-4
 - straight-through cable pin-out ... B-4
 - switch-to-computer connection ... B-2
 - switch-to-switch or hub connection ... B-3
 - testing ... 3-9

V

- VLAN
 - effect on basic switch operation ... 1-9
- VT-100 terminal
 - serial cable connection for ... 2-14

W

- wall
 - mounting switch on ... 2-11

