

---

# HP 10Base-T Hubs

HP Networking

## Installation

---

HP 10Base-T Hub 12  
HP 10Base-T Hub 12M

HP 10Base-T Hub 24  
HP 10Base-T Hub 24M



*For world-wide support on all  
HP Network Connectivity Products  
visit our web site at:*

[http://www.hp.com/go/network\\_city](http://www.hp.com/go/network_city)

Less Work, More Network

---

# HP 10Base-T Hubs

---

Installation Guide

**© Copyright 1998 Hewlett-Packard Company  
All Rights Reserved.**

This document contains information which is protected by copyright. Reproduction, adaptation, or translation without prior permission is prohibited, except as allowed under the copyright laws.

### **Publication Number**

5967-0852  
November, 1997

### **Applicable Product**

HP J3300A 10Base-T Hub 12  
HP J3301A 10Base-T Hub 12M  
HP J3302A 10Base-T Hub 24  
HP J3303A 10Base-T Hub 24M

### **Trademark Credits**

MS-DOS® and Microsoft® are U.S. registered trademarks of Microsoft Corporation. Ethernet is a registered trademark of Xerox Corporation.

### **Disclaimer**

The information contained in this document is subject to change without notice.

HEWLETT-PACKARD COMPANY MAKES NO WARRANTY OF ANY KIND WITH REGARD TO THIS MATERIAL, INCLUDING, BUT NOT LIMITED TO, THE IMPLIED WARRANTIES OF MERCHANTABILITY AND FITNESS FOR A PARTICULAR PURPOSE. Hewlett-Packard shall not be liable for errors contained herein or for incidental or consequential damages in connection with the furnishing, performance, or use of this material.

Hewlett-Packard assumes no responsibility for the use or reliability of its software on equipment that is not furnished by Hewlett-Packard.

### **Warranty**

See the warranty booklet and the registration form included with the product.

A copy of the specific warranty terms applicable to your Hewlett-Packard products and replacement parts can be obtained from your HP Sales and Service Office or authorized dealer.

# Support is as close as the World Wide Web!

---

## [http://www.hp.com/go/network\\_city](http://www.hp.com/go/network_city)

Follow the links that lead you to Support, Drivers, and Technology. Our Web site has everything you need in one place, around the clock, seven days a week:

- Software, agent firmware, and drivers (see “When Downloading Files”, below)
- Troubleshooting information
- Product information
- Support contacts

### Your HP Reseller can help, too!

Be sure to talk to your reseller about the support services they offer for your HP networking products.

### Other HP Electronic Support Services

If you don't have World Wide Web access, these sources provide firmware, drivers, and technical information.

#### CD-ROM

Every network-manageable hub and switch comes with a CD-ROM that includes management software, MIBs, documentation, and other useful technical information.

#### HP FTP Library Service

```
ftp ftp.hp.com
Name: anonymous
Password: john@mycompany.com
ftp> bin
ftp> cd /pub/networking/software
ftp> get filename
ftp> quit
```

Use your FTP software to ftp to HP's site.  
Log in as “anonymous”  
Enter your email address as your password.  
Enter bin as the file transfer type  
Go to the directory that has the files  
Transfer the file you want to your computer  
Quit the connection.


#### HP Bulletin Board Service (BBS)

With your communication/terminal emulation software:

- In the U.S., dial 208-344-1691
- In other countries, contact your reseller or local HP Customer Care Center (see chart on other side) for the BBS telephone number for your country.

Follow the menu system to find and download the latest software, agent firmware, or drivers for your HP networking product.

#### When Downloading Files

Files are typically named to correspond to the HP product number of the product they're intended for. If the file you download has a file extension of “.exe”, it is a compressed file. For example, the product HP J3200A may have a file **j3200a.exe** that is extracted by typing **j3200a** .

### HP FIRST Fax Retrieval Service

HP FIRST is an automated fax retrieval service that is available 24 hours a day, seven days a week. HP FIRST provides a variety of product and technical information.

To access HP FIRST, dial one of the following telephone numbers:

- In the U.S. and Canada, dial 800-333-1917 from your fax machine or touch-tone phone.
- In other countries, contact your reseller or local HP Customer Care Center (see chart below) for the HP FIRST telephone number for your country.
- To access the U.S./Canada HP FIRST system from another country, dial +1 208 344 4809 from your fax machine.

Enter the ID number of the document you want to receive. If you're not sure what the ID number is, you can request an index by following the prompts. The information will be sent to you by return fax.

### Additional HP Support Services

Limited free telephone support is offered through the HP Customer Care Center (CCC) in your country:

| North America                   |                   |                |                  | Asia Pacific |                |
|---------------------------------|-------------------|----------------|------------------|--------------|----------------|
| United States                   | 970-635-1000      | Hungary        | 36 (1) 252 4505  | Australia    | 61 3 9272 8000 |
| Canada (English)                | 970-635-1000      | Ireland        | 01 662 5525      | China        | 8610 6505 3888 |
| Canada (French)                 | 800-387-3867      | Italy          | 02 26410350      | Hong Kong    | 800 96 7729    |
| Europe, Middle East, and Africa |                   | Middle East    | +41 22/780 71 11 | India        | 91 11 682 6035 |
| Africa                          | +41 22/780 71 11  | Netherlands    | 020 606 8751     | Indonesia    | 6221 350 3408  |
| Austria                         | 0660 6386         | Norway         | 22 11 6299       | Japan        | 81 3 3335 8333 |
| Belgium (Dutch)                 | 02 626 8806       | Poland         | 48 22 37 50 65   | Korea        | 82 2 3270 0803 |
| Belgium (French)                | 02 626 8807       | Portugal       | 01 441 7199      | Malaysia     | 03 295 2566    |
| Czech Republic                  | 42 (2) 471 7321   | Russia         | 7095 923 50 01   | New Zealand  | 09 356 6640    |
| Denmark                         | 3929 4099         | Spain          | 902 321 123      | Philippines  | 63 2 867 3551  |
| English (non-UK)                | +44 171 512 52 02 | Sweden         | 08 619 2170      | Singapore    | 65 272 5300    |
| Finland                         | 0203 47 288       | Switzerland    | 0848 80 11 11    | Taiwan       | 886 2 717 0055 |
| France                          | 01 43 62 34 34    | Turkey         | 90 1 224 59 25   | Thailand     | 661 4011       |
| Germany                         | 0180 52 58 143    | United Kingdom | 0171 512 52 02   |              |                |

Each CCC takes calls during the normal HP business hours for its location. This service is for basic questions only, relating to installation, general configuration, troubleshooting, and usage. Advanced topics including network design, consultation, performance tuning, and configuration recommendations are not available through this service.

HP has other telephone and onsite services available that provide you with expert HP technical assistance. HP SupportPacks, purchased from your local reseller, provide a variety of services, including advanced technical support and around-the-clock availability. Other services offer network design, consulting, or remote telephone support. Contact your reseller or local HP Sales and Support Office for more information.

## Less Work, More Network

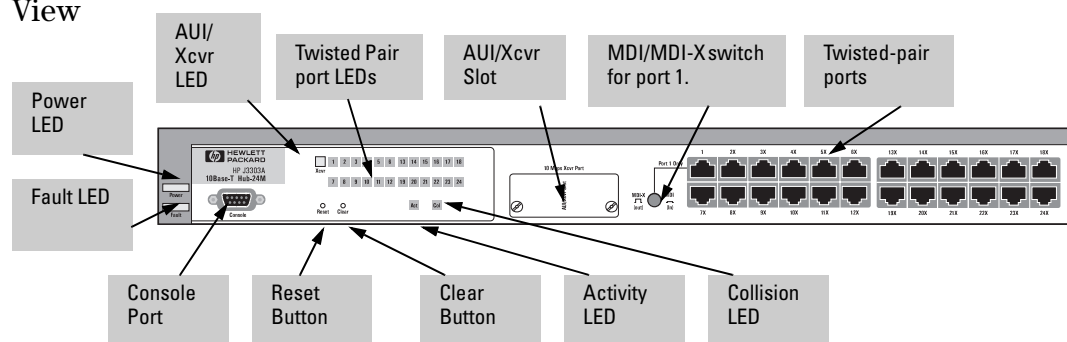
## HP 10Base-T Hubs

The HP 10Base-T hubs are a family of multiport repeaters. With these hubs, you can connect computers, printers, and servers together for file sharing. These hubs are compliant with the IEEE 802.3 Type 10Base-T standard and support both 802.3 and Ethernet networks. The HP 10Base-T hubs follow these two standards by providing these features:

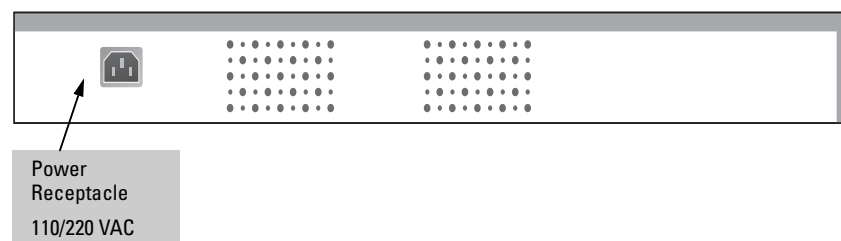
- lighting the hub's port LED when it detects the connected device is powered on and cable is good.
- retransmitting data that did not successfully arrive at the destination device (collision detection).

A sample hub from the family is shown here to indicate common features.

### Front View

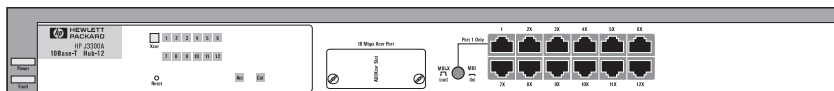


### Rear View

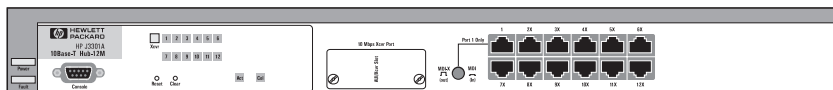


**Figure 1. The HP J3303A 10Base-T Hub 24M: Front and Rear Views**

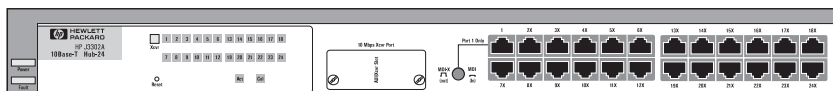
The following illustrations show each of the four hubs in the HP 10Base-T Hubs family.



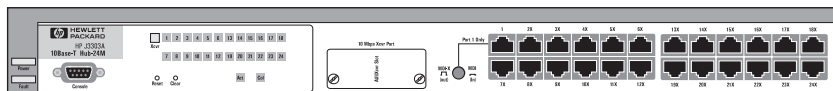
**Figure 2. The HP J3300A 10Base-T Hub 12**



**Figure 3. The HP J3301A 10Base-T Hub 12M**



**Figure 4. The HP J3302A 10Base-T Hub 24**



**Figure 5. The HP J3303A 10Base-T Hub 24M**

## Features

The following tables detail information about features on the HP 10Base-T Hubs.

### Feature Description

The following table provides descriptive information about features on the HP 10Base-T Hubs.

**Table 1. HP 10Base-T Hub Feature Descriptions**

| Feature Type                  | Feature Description  |
|-------------------------------|--|
| Network Connections           | <ul style="list-style-type: none"> <li>• <b>12 or 24 twisted-pair ports</b> to connect to end nodes or other devices.</li> </ul>   |
|                               | <ul style="list-style-type: none"> <li>• <b>An MDI/MDI-X (Media Dependent Interface)</b> switch for Port 1 which allows you to connect either an end node (MDI-X position) or to cascade a hub (MDI position) to the port, using a "straight-through" twisted-pair cable in both cases. Port 1 has a factory default of MDI-X, but can be toggled to an MDI state with the adjacent push-button. All other ports are always MDI-X for connection to computers and other end nodes through a twisted-pair "straight-through" cable.</li> </ul>  |
|                               | <ul style="list-style-type: none"> <li>• An AUJ/Xcvr slot for installing one of the HP Transceiver modules:</li> <li>• HP Fiber-Optic Transceiver Module (HP J2606A) -- for 10Base-FL. Allows you to connect your hub to a fiber-optic backbone.</li> <li>• HP Twisted-Pair Transceiver Module (HP J2607A) -- for 10Base-T. Adds another RJ-45 port for a total of 13 twisted-pair ports on the J3300A and the J3301A hubs.</li> <li>• HP ThinLAN Transceiver Module (HP J2608A)-- for 10Base2.</li> <li>• HP AUJ Port Module (HP J2609A) -- to attach external transceivers.</li> </ul> |
| Easy-to-Use Design            | <ul style="list-style-type: none"> <li>• <b>Hub Status LEDs</b> showing power, activity, collisions, fault and Xcvr, each providing quick, easy-to-read hub status information and troubleshooting help.</li> <li>• <b>Port Status LEDs</b> showing transceiver and port status, providing quick, easy-to-read port status information and troubleshooting help.</li> </ul>  |
|                               | <ul style="list-style-type: none"> <li>• <b>Metal brackets</b> (included with the hub) that can be easily attached to the hub for mounting the hub in a standard 19-inch telco rack or on a rack. Also, table and wall mounting is supported.</li> </ul>   |
| Standards-Based Compatibility | <ul style="list-style-type: none"> <li>• <b>IEEE 802.3 Type 10Base-T standard compatibility</b> to support both 802.3 and Ethernet networks.</li> </ul>  |

| Feature Type       | Feature Description  |
|--------------------|--|
|                    | <ul style="list-style-type: none"> <li>• <b>Advanced embedded SNMP agent code in both the HP J3301A and HP J3303A</b>, enabling these hubs to be managed remotely from a network management station using SNMP over IP (using the configured IP address). The agent code also provides HP EASE (Embedded Advanced Sampling Environment), which samples network data for enhanced diagnostics from a network management station. Also, the hubs support the RMON MIB. The HP J3301A and HP J3303A both can be managed in any of these three ways: <ul style="list-style-type: none"> <li>– using a Simple Network Management Protocol application that runs in Microsoft Windows and Unix (HP ASA).</li> <li>– using a World Wide Web browser application that runs in Netscape Navigator or Microsoft Internet Explorer (the Browser Interface).</li> <li>– using an ASCII Console Interface.</li> </ul> </li> </ul> |
| Reliable Operation | <ul style="list-style-type: none"> <li>• <b>A self-test</b> for fault identification when the hub is powered on or when it is reset. (The hub can be reset from a network management station or by pressing the Reset button.)</li> </ul>  |
| Other Features     | <ul style="list-style-type: none"> <li>• <b>Password setting capability on both the HP J3301A and HP J3303A</b>, enabling you to add and remove passwords, as needed, for selective entry into the hub management environment. Passwords can be set from a World Wide Web browser, a network management station, through an ASCII Console session. If you forget your password, and are locked out of the hub's management environment, you can remove the password by pressing the Clear button.</li> </ul>   |
|                    | <ul style="list-style-type: none"> <li>• <b>An RS-232 serial port on both the HP J3301A and HP J3303A that provides out-of-band management access including:</b> <ul style="list-style-type: none"> <li>– An ASCII console to configure, monitor, and troubleshoot the hub.</li> <li>– Variable baud rates on the hub's out-of-band management RS-232 port, and automatic sensing of the selected baud rate when connecting to a terminal device.</li> <li>– Full V.22bis modem line control for remote out-of-band management access to the hub.</li> <li>– Updatable firmware that enables enhancements to be downloaded either from a computer attached to the out-of-band management port via Xmodem or over the network via TFTP.</li> </ul> </li> </ul>  |

## Feature Comparison

The following table details what features are present on the managed and the unmanaged hubs.

**Table 2. Feature Comparison Between Managed and Unmanaged Hubs**

| Feature  | HP J3300A/HP J3302A<br>(Unmanaged) | HP J3301A/HP J3303A<br>(Managed) |
|--|------------------------------------|----------------------------------|
| IEEE 802.3 10Base-T ports                            | ✓                                  | ✓                                |
| Transceiver Slot                                     | ✓                                  | ✓                                |
| MDI/MDI-X Selection Button                           | ✓                                  | ✓                                |
| Rack Mounting Capability                             | ✓                                  | ✓                                |
| Wall Mounting Capability                             | ✓                                  | ✓                                |
| World Wide Web management interface                  |                                    | ✓                                |
| HP EASE  |                                    | ✓                                |
| SNMP   |                                    | ✓                                |
| RMON -- 9 Groups                                     |                                    | ✓                                |
| ASCII Console Management                             |                                    | ✓                                |
| Telnet Console Management                            |                                    | ✓                                |
| Modem Support  |                                    | ✓                                |
| Out of Band Management for remote console connection |                                    | ✓                                |
| Eavesdrop Prevention                                 |                                    | ✓                                |
| Intruder Prevention                                  |                                    | ✓                                |
| Backup Links   |                                    | ✓                                |
| IP Configuration                                     |                                    | ✓                                |
| Community Name Management                            |                                    | ✓                                |
| Alarms   |                                    | ✓                                |
| MIB II   |                                    | ✓                                |
| MAU Connectivity                                     | ✓                                  | ✓                                |
| Link Test  |                                    | ✓                                |
| Ping Test  |                                    | ✓                                |
| ThinLAN support                                      | ✓                                  | ✓                                |
| Fiber Optic support                                  | ✓                                  | ✓                                |
| Console Password Protection                          |                                    | ✓                                |
| Mounting Brackets for Rack                           | ✓                                  | ✓                                |
| Transceiver Module Support                           | ✓                                  | ✓                                |
| RS-232 download                                      |                                    | ✓                                |

## Factory Default Settings

The following table details the factory defaults for all of your hub settings.

**Table 3. Factory Default Settings on HP 10Base-T Hubs**

| <b>Feature</b>                       | <b>J3300A/J3302A</b>         | <b>J3301A/J3303A</b>         |
|--------------------------------------|------------------------------|------------------------------|
| Port Status                          | Enabled                      | Enabled                      |
| MDI/MDI-X Port Status                | MDI-X (Button not depressed) | MDI-X (Button not depressed) |
| Power (when power cord is connected) | On                           | On                           |
| Port Counters                        | --                           | All 0                        |
| Link Beat detection                  | Enabled                      | Enabled                      |

---

# Contents

## 1 Installing the Hub

|   |      |
|---|------|
| <b>Installing Your Hub</b> .....                            | 1-2  |
| 1. Verify included parts .....                              | 1-2  |
| 2. Install the transceiver module .....                     | 1-2  |
| 3. Verify the hub operates correctly .....                  | 1-3  |
| 4. Mount the hub .....                                      | 1-5  |
| Rack or Cabinet Mounting .....                              | 1-5  |
| Wall Mounting .....   | 1-7  |
| Table Mounting .....  | 1-7  |
| 5. Connect the hub to your network .....                    | 1-8  |
| Connecting Hubs Together .....                              | 1-9  |
| Twisted-Pair Cascade Connections .....                      | 1-9  |
| ThinLAN Connections .....                                   | 1-11 |
| Connecting the HP 10Base-T Hubs to a Fiber-Optic Backbone . | 1-12 |

## 2 Troubleshooting

|   |     |
|---|-----|
| Troubleshooting Approaches .....                | 2-1 |
| Diagnosing with the LEDs .....                  | 2-2 |
| Interpreting LED Status .....                   | 2-3 |
| Interpreting Hub Status LEDs .....              | 2-3 |
| Interpreting Port Status LEDs .....             | 2-4 |
| LED Operation .....                             | 2-5 |
| Hub Maintenance Tasks .....                     | 2-6 |
| Testing the Hub Only .....                      | 2-6 |
| Clearing a Password for the ASCII Console ..... | 2-6 |
| Running Connectivity Tests .....                | 2-7 |
| Obtaining Firmware Enhancements .....           | 2-8 |

## **A Specifications**

### **B Cables and Connectors**

|  |     |
|--|-----|
| Straight-Through Twisted-Pair Cable for Hub-to-Computer Network Connection ..... | B-1 |
| Twisted-Pair Straight-Through Cable .....  | B-3 |
| Twisted-Pair Crossover Cable .....   | B-3 |
| RS-232 Connector and Cable Pin-Outs .....  | B-3 |
| Minimum Cable Pinout for ASCII Console Connection .....                          | B-4 |
| .....  | B-4 |

### **C Safety and Regulatory Statements**

### **Index**

# Installing the Hub

---

This chapter describes how to install the hub. Topics in this chapter include

- verifying included parts
- installing the transceiver module
- verifying the hub operates correctly
- mounting the hub
- connecting the hub to your network
- connecting hubs together

---

# Installing Your Hub

To install and configure your hub, you must complete six basic tasks. They are:

- locating and verifying the necessary parts
- installing a transceiver module
- connecting the hub to a power source
- mounting the hub
- connecting the hub to your network

## 1. Verify included parts

Each HP 10Base-T Hub has the following components shipped with it:

- This manual. The HP J3301A and HP J3303A both come with the *HP 10Base-T Hubs Management and Configuration* guide (5967-0853).
- A power cord, one of the following:
  - Australia/New Zealand (8120-6803)
  - Denmark (8120-6806)
  - Europe (8120-6802)
  - Israel (8120-6799)
  - South Africa (8120-6807)
  - Switzerland (8120-6807)
  - United Kingdom (8120-6801)
  - U.S./Canada/Mexico (8120-6805)
- accessory kit (5064-2053):
  - bumper feet (4)
  - bracket-to-rack screws 12-24 (7/16") (4)
  - bracket-to-hub screws M4 (5/16") (4)
  - mounting brackets for 44.55mm (1.75")-height hub (5183-1381)

## 2. Install the transceiver module

You may want to install the transceiver module and any external transceiver you may want to attach to it before installing the hub. Transceiver modules may require more lengthy protrusions created by the greater widths of the different cables and connectors you may attach to a module (for example, an

external transceiver). Because of these widths, clearance in front of your hub may be a factor in the placement of the device or stack that contains protruding transceiver connectors, for example, a BNC connectors.

Inspect your installation site and identify whether enough room will be available for the installed transceiver to be connected. Then see the guide that shipped with your external transceiver for installation instructions. For HP external transceivers, see the *HP Recessed Transceivers Installation Guide* (p/n 5962-0066) for specific instructions.

Your transceiver modules can be one of the following:

- HP J2606A Fiber-Optic Transceiver Module
- HP J2607A Twisted-Pair Transceiver Module
- HP J2608A ThinLAN Transceiver Module
- HP J2609A AUI Port Module

### 3. Verify the hub operates correctly

Before mounting the hub, connect it to a power source and verify that the hub will operate correctly.

1. Plug the power cord into the hub's power cord receptacle and into an AC power source.



Connect female end of included power cord into male receptacle here and male end of power cord to an alternating current power source.

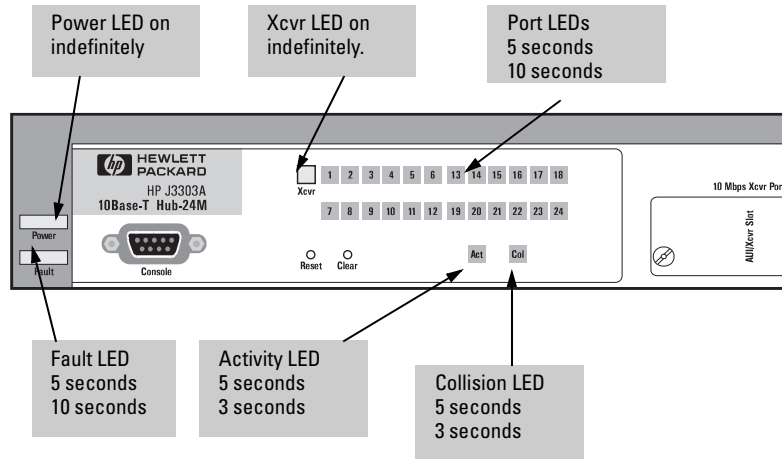
---

#### Notes

---

The hub does not have a power switch; it is powered on when the power cord is plugged in.

- Check the LEDs on the hub's front panel. When the hub is powered on, it performs a power-on self test. See the table below for the LED self test time that occurs during the self test. Note the upper number is for the HP J3300A/HP J3302A and the lower number is for the HP J3301A/HP J3303A.



**Figure 1-1. Self Test times for LEDs.**

If the hub passes self test, the LEDs behave as described in the following table. If the LEDs behave in a different way, the hub may have failed self test. See the LED operation table in chapter 2, “Troubleshooting” for a complete description of the LED behavior.

**Table 1-1. Self Test times for LEDs**

| LED                 | HP J3300A/HP J3302A                                       | HP J3301A/HP J3303A                                       |
|---------------------|---|---|
| Port LEDs, Fault,   | 5 seconds   | 10 seconds  |
| Activity, Collision | 5 seconds   | 3 seconds   |
| Xcvr                | Stays on if module installed. Off if no module installed. | Stays on if module installed. Off if no module installed. |
| Power               | Stays On  | Stays On  |

Note that once you have connected cables to the hub, an AUI transceiver LED or twisted pair Port LED stays on if link beat has been detected at the port from an incoming device and the port is enabled. A Port LED turns off if link beat is not detected.

When the self test completes successfully, the LEDs go into their normal operational states. If a hub hardware fault exists, the hub will not complete self test. This will be indicated by an abnormal LED pattern, such as all port LEDs staying lit indefinitely. Note that the normal operational state could include indefinitely blinking LEDs in the event of a detected intruder. For managed HP 10Base-T Hubs, see your *HP 10Base-T Hubs Management and Configuration* guide for more information on Intruder Detection and flashing LEDs associated with it.

If the self test time range elapses and the Fault LED continues to stay on instead of turning off, the hub may have an error condition. If repeating the self test does not correct the problem and the Fault LED still stays continuously on, contact your HP authorized reseller for replacement information. After the hub has passed its self test, you are ready to mount the hub. Unplug the hub and proceed to the next step.

## 4. Mount the hub

**Before mounting the hub, unplug it.** The HP 10Base-T Hubs can be mounted in three ways:

1. in a rack or cabinet
2. on the wall
3. on a table

The hardware for mounting the hub is included in the accessory kit (5064-2053) packed with the hub. See Appendix C, “Safety and Regulatory Statements,” for general mounting precautions.

### Rack or Cabinet Mounting

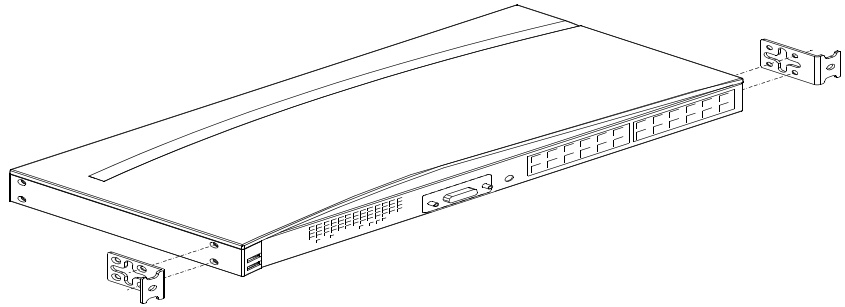
---

#### Warning

---

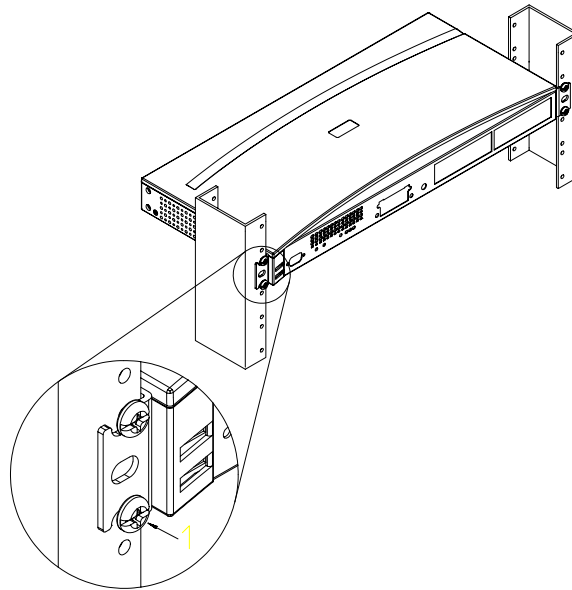
**The rack or cabinet should be adequately secured to prevent it from becoming unstable and/or falling over.** Please see Appendix C, “Safety and Regulatory Statements,” for precautions and warnings associated with rack mounting.

1. Using a Phillips Crosshead No. 2 screwdriver, attach the mounting brackets to the hub with No. M4 (5/16") silver screws (included in the accessory kit).



**Figure 1-2. Hub-to-Bracket Assembly**

2. Position the hub in the rack or cabinet and slide it up or down until the rack holes line up with the bracket holes.
3. Then attach the bracket to the rack with the No. 12-24 (7/16") screws and black nylon washers included in the accessory kit with a Phillips Crosshead No. 2 screwdriver. A flatblade screwdriver will also work in assembling the hub to the rack. Make sure you have screws that fit your cabinet or rack before mounting the hub.



**Figure 1-3. Hub-to-Rack Assembly**

## Wall Mounting

Using a Phillips (crosshead) No. 2 screwdriver, attach the mounting brackets to the hub with 8-mm (approximately 5/16") M4 screws included in the accessory kit. Then attach the hub to a wood surface (minimum 1/2-inch plywood or equivalent) with No. 12 (5/8") wood screws with a Phillips Cross-head No. 2 screwdriver.

HP recommends that the bottom of the hub should be flush with the wall. The brackets should be positioned at the front of the hub. The face of the hub should be pointing up.

Note that the wood screws are not included in the accessory kit. Wood screws have a pointed end for boring into the wood, unlike rack screws which are flat on the end.

## Table Mounting

To place the hub on a table or other horizontal surface, no special tools are necessary. Apply the four feet included in the accessory kit onto the bottom of the hub. Be certain to pick a sturdy table in an uncluttered area. You may want to secure the hub's cables to the leg of the table to prevent people from tripping over them.

## 5. Connect the hub to your network

Connect the hub to an AC power source. With the hub mounted, you are now ready to connect the hub to your network. Typical hub connections are:

- **hub-to-device connections.** Connecting to network devices such as computers, and printers.
- **hub-to-hub and hub-to-switch connections.** Connecting to another Ethernet hub.
- **hub-to-network backbones.** Connecting to a network backbone.

This section describes the different ways you can connect your hub to your network.

To connect a device to the hub, using unshielded twisted-pair (UTP) cable, push the RJ-45 plug at one end of the cable into the RJ-45 jack on the hub until the tab on the plug clicks into place.

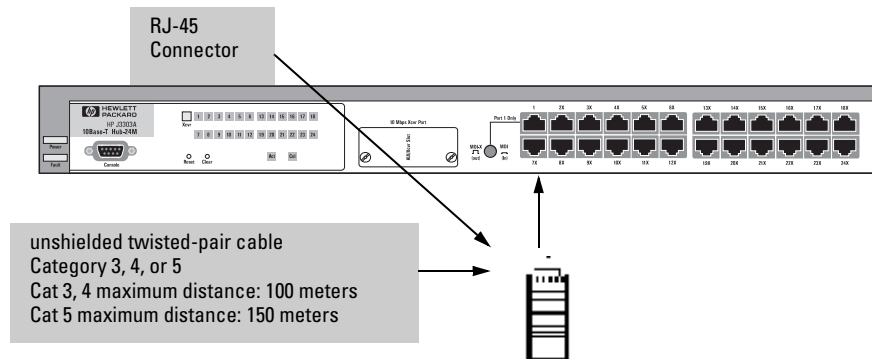


Figure 1-4. The RJ-45 Connector

## Connecting Hubs Together

### Twisted-Pair Cascade Connections

To expand your network, the hub can be connected to other hubs with straight-through cable by using the Media Dependent Interface (MDI/MDI-X) switch.

The MDI/MDI-X switch controls how the signals are sent through the twisted-pair cable connected to Port 1. The hub is shipped with the switch in the MDI-X position. The switch has two positions:

- **In the MDI position**, use Port 1 to connect your hub to another hub. In this position, the hub reverses the Tx and Rx port pairs for you. This allows you to use “straight-through” category 3 or 4 cable rather than “cross-over” cable to connect two hubs together. The cable length can be up to 100 meters. Category 5 cable length can be up to 150 meters.

Be sure that only one of the two hubs is using an MDI port; the hub-to-device connection must always have MDI at one end (usually a transceiver), and MDI-X at the other end (usually a hub or switch), when connecting the two with a straight-through cable.

- **In the MDI-X position**, use Port 1 to connect your hub to a PC or similar device using “straight-through” cable. In this position, the port is wired the same as all other twisted-pair ports on the hub. Cable lengths for these connections can be up to 100 meters.

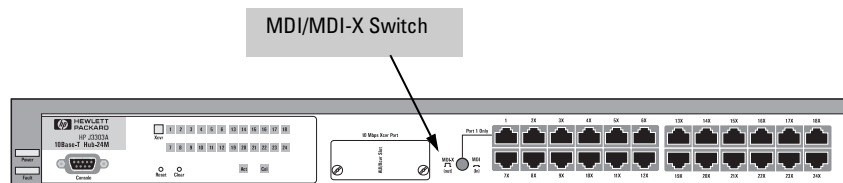
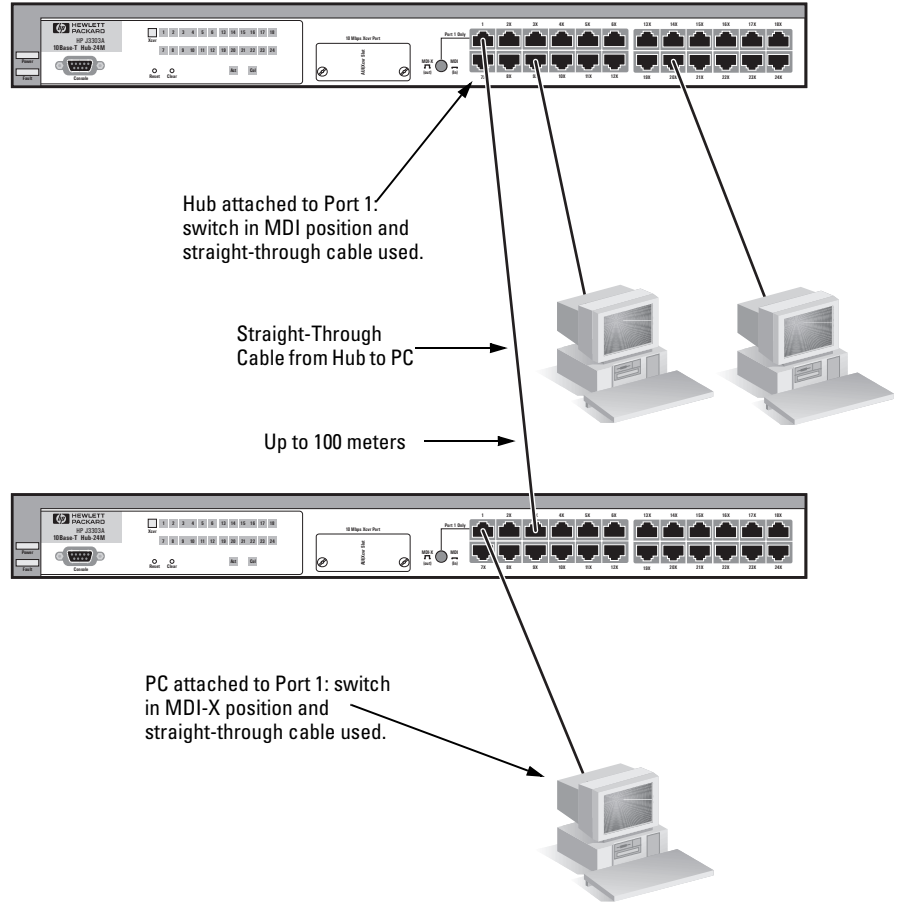


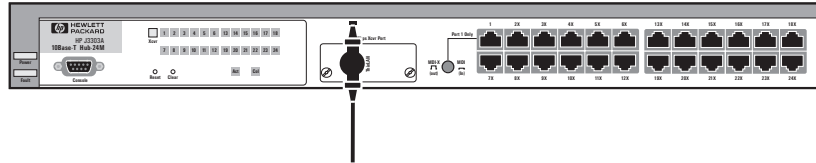
Figure 1-5. The MDI/MDI-X Switch

In the following illustration, the top hub in the stack is connected to two end nodes and to a second hub. Note the second hub shows Port 1 connecting to a PC, using a straight through twisted pair cable with the port in the MDI-X position.



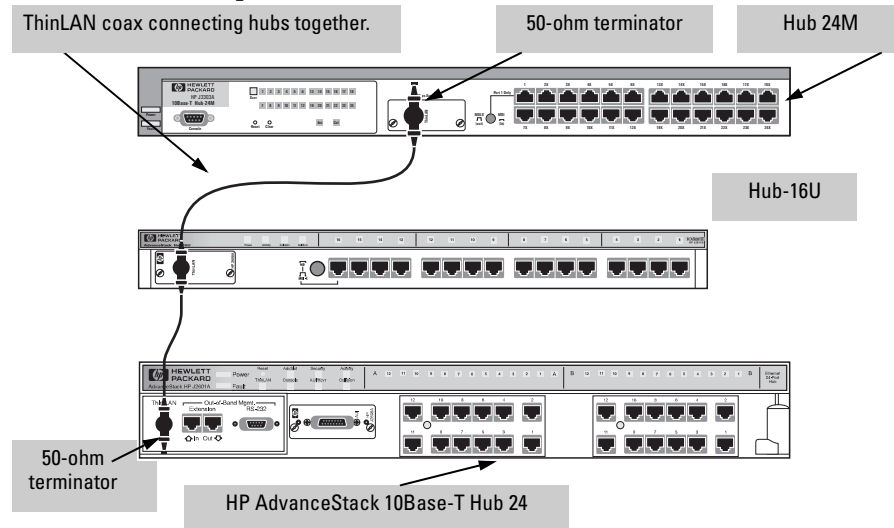
## ThinLAN Connections

With an HP ThinLAN Transceiver Module for 10Base2 networks installed in the transceiver slot, you can connect your hub or a stack of hubs to a 10Base-2 ThinLAN network. The following illustration shows a hub with an HP ThinLAN Transceiver.



**Figure 1-6. ThinLAN Connector**

You can connect up to 30 hubs together on a common ThinLAN segment. The ThinLAN segment can include a computer attached to a hub at one end of the segment that can communicate with a computer attached to another hub at the other end of the segment. By using the BNC port on the module, the maximum repeater hop-count increment through the entire segment is only two. The following illustration shows you how to connect three hubs together from one ThinLAN port to another.



**Figure 1-7. 10Base-T Hub Stack Using ThinLAN Coax Connection**

---

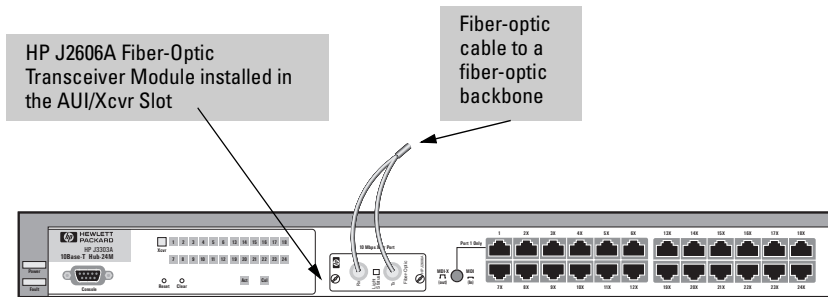
**Note**

---

Each ThinLAN cable segment must be terminated using a 50-ohm terminator at each end. In the illustration above, a 50-ohm terminator is placed at each end of the cable segment.

### Connecting the HP 10Base-T Hubs to a Fiber-Optic Backbone

With a Fiber-Optic transceiver for 10Base-FL networks, you can connect your hub to a fiber-optic backbone. The following illustration shows a hub with a Fiber-Optic transceiver connected to a fiber-optic backbone:



**Figure 1-8. Fiber-Optic Backbone Connection**

For more information about cabling configuration, see the documentation accompanying the optional recessed transceivers. Also, see the *Designing HP AdvanceStack Networks* (Part Number 5965-6578E) guide for information on valid network topologies.

# Troubleshooting

---

This chapter describes ways to troubleshoot the hub. Topics covered are:

- troubleshooting approaches
  - using a checklist to diagnose the hub
  - diagnosing with the LEDs
  - hub maintenance tasks
- 

## Troubleshooting Approaches

You can diagnose problems on all HP 10Base-T Hubs by checking the LEDs on the front of the hub as described in the section, “Diagnosing with the LEDs” in this chapter. Note that information in this chapter is also covered in chapter 7 of the *HP 10Base-T Hubs Management and Configuration* guide.

You can diagnose hubs on the HP J3301A and HP J3303A, the managed hubs, by

- By using the Browser Interface, a Web-based interface that provides a full management environment.
- By using the ASCII console’s diagnostic functions as described in the *HP 10Base-T Hubs Management and Configuration* guide.
- By using the HP AdvanceStack Assistant (ASA) or other SNMP management tool as described in the online help in the management application.

## Diagnosing with the LEDs

Use the following table to diagnose the problem with your HP 10Base-T Hub.

| Problem   | Solution  |
|---|---|
| How do I reset the hub?                             | <p>You can reset the hub three five different ways:</p> <ul style="list-style-type: none"> <li>• From the device, remove the plug on the power cord from the power source or the hub and reconnect it.</li> <li>• From the device, press the Reset Button.</li> <li>• From the ASCII Console Interface, select either the Reboot Hub option to preserve your settings or select the Reset Hub to Factory Default option to completely reset the hub's factory defaults.</li> <li>• From the Browser Interface, select the Factory Reset Button.</li> <li>• From HP AdvanceStack Assistant, perform a reset from the Reset Parameters dialog box.</li> </ul> <p>If this condition persists, see your LAN dealer.</p> |
| None of the LEDs are on.                            | <p>Verify that the power cord is plugged into an active power source and to the hub. Make sure these connections are snug. Try power cycling the hub by unplugging and plugging the hub back in.</p> <p>If the Power LED is still not on, verify that the AC source works by plugging another device into the outlet. Or try plugging the hub into a different outlet or try a different power cord.</p> <p>If this condition persists, call your HP-authorized LAN dealer or HP representative for assistance.</p>   |
| I lost the password.                                | Press the Clear button for 10 seconds. See page 2-4 for more details.   |
| IP configuration errors have been reported.         | Use the ASCII console's IP Configuration function as described in the <i>HP 10Base-T Hubs Management and Configuration</i> guide.   |
| I want to see if each cable is connected correctly. | Run Link Test in the ASCII Console Interface. See the <i>HP 10Base-T Hubs Management and Configuration</i> guide.   |
| A user can't send data to another user.             | Use the Ping or Link Test in the ASCII Console Interface. See the <i>HP 10Base-T Hubs Management and Configuration</i> guide.   |
| The Fault LED is on.                                | Remove the plug on the power cord from the power source and reconnect it. If problem persists, the device has an internal failure. Contact your HP authorized dealer or reseller.   |

Most problems with the hub can be diagnosed using the LEDs on its front panel. The following section describes the normal LED pattern during self-test, and LED patterns that indicate error conditions on the hub.

## Interpreting LED Status

Two types of LEDs exist on the hub. They are:

- Hub Status LEDs. These LEDs reflect certain conditions that exist on the hub at large and are not explicitly referring to a given port.
- Port Status LEDs. These LEDs reflect basic conditions (for example, Link Beat being enabled) that exist on a specific port.

Status information for both are described in the following tables.

### Interpreting Hub Status LEDs

The hub status LEDs indicate whether the hub is functioning properly.

| LED       | LED Color | Meaning of LED  |
|-----------|-----------|---|
| Power     | Green     | <b>On</b> indicates the hub is receiving power.   |
|           |           | <b>Off</b> indicates the hub is not receiving power.  |
| Activity  | Green     | <b>Flickering</b> (rapid flashing) indicates a packet is being transmitted to or from a port. Normally, the LED appears to flicker. In heavy traffic, it may appear on all the time.<br><b>Off</b> indicates no packet is being transmitted to or from a port.  |
| Fault     | Orange    | <b>On</b> indicates an error has been detected on the hub.<br><b>Off</b> indicates no error has been detected on the hub.<br><b>Port LED Flash</b> on for .75 seconds and turn off for .75 seconds, indicating the port is partitioned. The Fault LED does NOT illuminate when ports are partitioned. |
| Collision | Orange    | <b>On</b> indicates a collision is detected. If it appears on continuously (with no flicker), it is a possible indicator of a network fault or an improperly terminated cable.<br><b>Off</b> indicates no collision has been detected.  |

## Interpreting Port Status LEDs

The following table provides LED port information for the HP J3301A and the HP J3303A.

| LED  | Color | Meaning of LED   |
|--|-------|--|
| <b>Twisted-pair Ports</b>  | Green | <b>On</b> indicates Link Beat is detected from the attached node and the port is enabled on the HP J3301A and HP J3303A.   |
|  |       | <b>Off</b> indicates the port is not receiving the link beat signal from the attached node.  |
|  |       | <b>Slow Flash*</b> indicates the port has been partitioned due to excessive collisions. This port will reenale when the connected device or cable is repaired.                   |
| <b>XCVR Port</b>   | Green | <b>On</b> indicates is enabled a transceiver module is installed.<br><b>Off</b> indicates the Xcvr port is disabled.<br>Slow Flash indicates the port has been auto-partitioned. |
| * The slow flash is approximately once every 1.5 seconds (.75 seconds on and .75 seconds off). |       |  |

The following table provides LED port information for the HP J3300A and the HP J3302A.

| LED  | Color | Meaning of LED  |
|--|-------|---|
| <b>Twisted-pair Ports</b>  | Green | <b>On</b> indicates Link Beat is detected from the attached node.   |
|  |       | <b>Off</b> indicates the port is not receiving the link beat signal from the attached node.   |
|  |       | <b>Slow Flash*</b> indicates the port has been partitioned. This port has been auto-partitioned due to excessive collisions. This port will reenale when the connected device or cable is repaired. |
| <b>XCVR Port</b>   | Green | <b>On</b> indicates the a transceiver module is installed.<br><b>Off</b> indicates the Xcvr port is disabled.<br>Slow Flash indicates the port has been auto-partitioned.                           |
| * The slow flash is approximately once every 1.5 seconds (.75 seconds on and .75 seconds off). |       |   |

## LED Operation

The tables on the following pages list the hub's LEDs, their possible states, and diagnostic tips to resolve any error conditions.

| LED patterns indicating problems                     |           |                   |                   | Diagnostic Tips   |
|--|-----------|-------------------|-------------------|---|
| Power  | Coll      | Port LED          | Fault             |   |
| <b>ON</b>  | *         | <b>OFF</b>        | *                 | <p>Check cabling on the indicated port all the way out to the device attached to that port. Faulty wiring or a bad connection could exist somewhere in that connection.</p> <p>The end node or hub attached to the port is off.</p> <p>The port may be disabled. Use the ASCII console or management application to enable the port.</p> <p>If Port 1, check the position of the MDI/MDI-X switch. See the figure in chapter 1 that details the MDI/MDI-X switch.</p> |
| <b>ON</b>  | <b>ON</b> | *                 | *                 | <p>Very frequent collisions are occurring, which could indicate a network fault or improperly terminated cable.</p>   |
| <b>ON</b>  | *         | <b>Slow Flash</b> | <b>Slow Flash</b> | <p>The port has been auto-partitioned because of an excessive collision condition. Check cable connections and status of attached network devices for causes of the excess collisions. The hub will automatically recover after certain IEEE 802.3 criteria are successfully met.</p>   |
| <b>ON</b>  | *         | <b>Fast Flash</b> | *                 | <p>Network management security violation occurred. See Port Security in Browser Interface or ASCII Console Interface.</p>   |
| <b>ON</b>  | *         | *                 | <b>ON</b>         | <p>The hub has failed its self-test. Power-cycle the hub. If this condition persists, call your HP-authorized LAN dealer or HP representative for assistance.</p>   |
| <b>*This LED is not important for the diagnosis.</b> |           |                   |                   |   |

## Hub Maintenance Tasks

There are several hub maintenance tasks you can perform. They include:

- testing the hub only
- clearing a password from the ASCII console
- running connectivity tests

Each of these tasks is described in the following sections.

### Testing the Hub Only

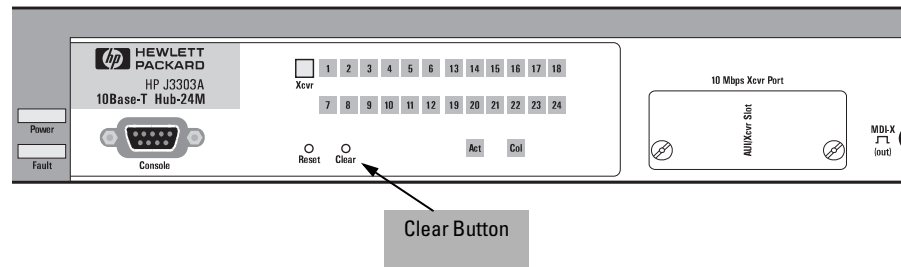
If you believe that the hub is not operating correctly, you can test it to determine normal operation in two ways:

- pressing the Reset Button.
- remove and reinsert the power cord for that hub.

This procedure will cause the hub to complete its power-on self-test. If any error conditions exist in the hub, the LEDs should display the condition.

### Clearing a Password for the ASCII Console

On the HP J3301A and HP J3303A, you can use the Clear button to clear a forgotten console password that was previously configured on the hub. The password is configured from the ASCII console. Note that the HP J3300A and HP J3302A hubs do not have a Clear button because they do not have password setting capability because they are unmanageable hubs.



**Figure 2-1. Clearing a Password**

To clear the password for the HP J3301A and the HP J3303A, follow these steps:

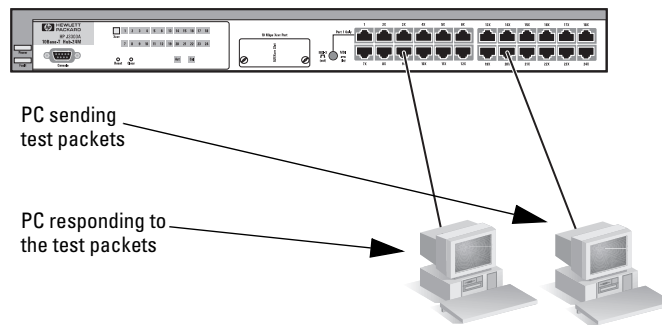
1. Verify the hub has powered-up, passed power-on self test, and that the Power LED is lit.
2. Press the Clear button for 10 seconds.

## Running Connectivity Tests

Both the hub and cabling can be tested by running an end-to-end communications test—a test that sends known data from one network device to another through the hub—such that you can verify that the data was correctly transmitted between the devices. Through both the ASCII Console Interface and the Browser Interface, you can run the following hub-to-node connectivity tests:

**Link Test.** A test of the link layer (MAC Address) connection between a local device and a designated remote device.

**Ping Test.** A test of the network layer (IP Address) path between the managed device and another device on an IP network that responds to IP packets.



**Figure 2-2. Running a Connectivity Test**

See your LAN adapter’s manual for information on running an end-to-end communication test.

## Obtaining Firmware Enhancements

In the future, Hewlett-Packard may provide improvements to the HP 10Base-T Hub 12M and the HP 10Base-T Hub 24M through firmware upgrades. The upgrade code can be downloaded from a PC attached to the hub's RS-232 port or over the network. The update procedures are described in documents that come with the firmware enhancements. Also, some downloading instructions are covered in chapter 6 of the *HP 10Base-T Hubs Management and Configuration* guide.

You can determine the current firmware version on the hub from the ASCII console. Look for the SNMP Agent EEPROM version number to determine the revision. When you access the console, the version number appears. It is also on the General System Information Screen under the Status and Counters Menu and the Identity Window in the Browser Interface.

To obtain the latest agent firmware, use the download instructions on the quick reference card included at the beginning of this manual.

Contact your HP-authorized LAN dealer or local HP sales office for the latest on firmware enhancements.

# Specifications

---

## Physical

|                 |                        |
|-----------------|------------------------|
| <b>Width:</b>   | 42.5 cm (16.7 in)      |
| <b>Depth:</b>   | 23.8 cm (9.4 in)       |
| <b>Height:</b>  | 4.36 cm (1.7 in)       |
| <b>Weight :</b> | 8 lbs 13 oz. (8.8 lbs) |

## Electrical

The hub automatically adjusts to any voltage between 100-127 and 200-240 volts and either 50 or 60 Hz.

|                         |               |               |
|-------------------------|---------------|---------------|
| <b>AC voltage:</b>      | 100–127 volts | 200–240 volts |
| <b>Maximum current:</b> | .5A max       | 0.3A max      |
| <b>Frequency range:</b> | 50/60 Hz      | 50/60 Hz      |

The maximum current ratings represent the current that could be drawn with an external transceiver attached to the hub.

## Environmental

|  | <b>Operating</b>            | <b>Non-Operating</b>           |
|--|-----------------------------|--------------------------------|
| <b>Temperature:</b>                            | 0°C to 55°C (32°F to 131°F) | -40°C to 70°C (-40°F to 158°F) |
| <b>Relative humidity:<br/>(non-condensing)</b> | 10% to 95% at 40°C (104°F)  | 10% to 90% at 65°C (149°F)     |
| <b>Maximum altitude:</b>                       | 4.6 Km (15,000 ft)          | 4.6 Km (15,000 ft)             |

## Connectors

The RJ-45 twisted-pair ports are compatible with the IEEE 802.3 Type 10Base-T standard.

## Electromagnetic

**Emissions:** FCC part 15 Class A  
EN 55022 Class A  
EN 55022 Class B  
CISPR-22 Class A  
VCCI Level I  
Complies with Canadian EMC Class A requirements.



Complies with Australia/New Zealand EMC Class A requirements.

**Immunity:** See the Declaration of Conformity for details at the end of Appendix C, "Safety and Regulatory Statements" in this guide.

**Safety:** IEC950 (1991) + A1, A2/.EN60950 I (1992)+A1,A2  
CSA950  
NOM-019-SCFI-1993  
UL1950

# Cables and Connectors

---

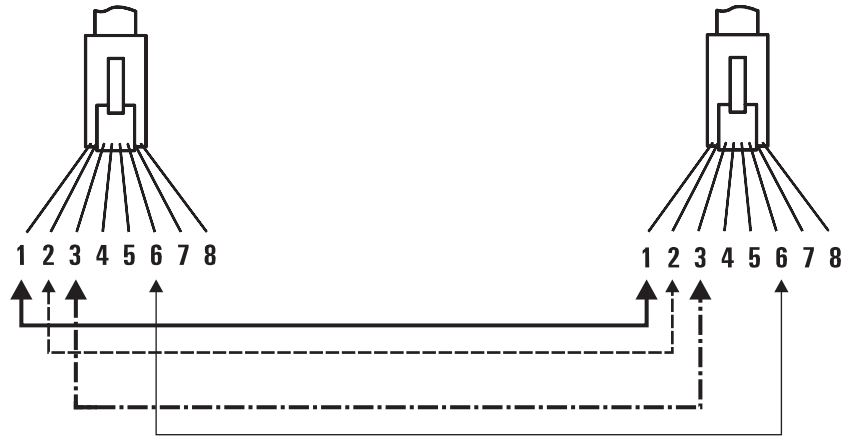
This appendix lists cables that have been tested and verified for use with the HP 10Base-T Hubs. The following topics are covered:

- overview
- twisted pair cable/connector pinouts
- RS-232 connector and cable pinouts

It also includes minimum pin-out information so, if you wish to use an unlisted cable, you can verify that the cables used in your installation are correctly wired. Note that each pin-out does not necessarily match the pin-out for the corresponding HP cable, but cables manufactured to follow the minimum pin-out will function correctly.

## Straight-Through Twisted-Pair Cable for Hub-to-Computer Network Connection

To connect PCs or other network devices to the hub, use a “straight-through” 10Base-T cable. The twisted-pair wires must be twisted through the entire length of the cable. The wiring sequence must conform to AT&T 258A (not USOC). See the Twisted-Pair Cable Pin Assignments section at the end of this chapter for a listing of the signals used on each pin.



---

**Note**

Pins 1 and 2 *must* be a twisted pair.  
Pins 3 and 6 *must* be a twisted pair.

Pins 4, 5, 7, and 8 are not used in this application, although they may be wired in the cable.

---

**Note**

Incorrectly wired cabling is the most common cause of problems for LAN communications. HP recommends that you work with a qualified LAN cable installer for assistance with your cabling requirements.

## Twisted-Pair Straight-Through Cable

| Hub End (MDI-X) |      | Computer or Transceiver End (MDI) |                |
|-----------------|------|-----------------------------------|----------------|
| Signal          | Pins | Pins                              | Signal         |
| (receive +)     | 1    | ←                                 | 1 (transmit +) |
| (receive -)     | 2    | ←                                 | 2 (transmit -) |
| (transmit +)    | 3    | →                                 | 3 (receive +)  |
| (transmit -)    | 6    | →                                 | 6 (receive -)  |

## Twisted-Pair Crossover Cable

| Hub End (MDI-X) |      | Computer or Transceiver End (MDI) |                |
|-----------------|------|-----------------------------------|----------------|
| Signal          | Pins | Pins                              | Signal         |
| (receive +)     | 1    | ←                                 | 3 (transmit +) |
| (receive -)     | 3    | ←                                 | 1 (transmit -) |
| (transmit +)    | 2    | →                                 | 6 (receive +)  |
| (transmit -)    | 6    | →                                 | 2 (receive -)  |

## RS-232 Connector and Cable Pin-Outs

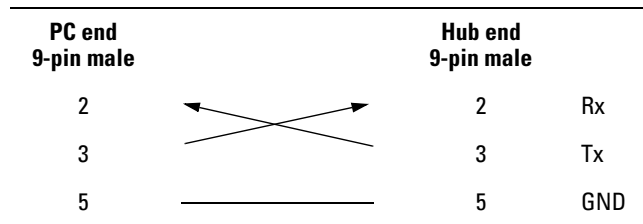
The RS-232 port connector on both the HP J3301A and the HP J3303A is wired as depicted in the following table.

| PIN | US  | CCITT | DIN |
|-----|-----|-------|-----|
| 2   | Rx  | 104   | D2  |
| 3   | Tx  | 103   | D1  |
| 4   | DTR | 108   | S1  |
| 5   | GND | 102   | -   |
| 6   | DSR | 107   | M1  |

Use the RS-232 port to connect a PC to be used as the console. To make this connection, you must use a null modem cable or you can use the minimum cable pin-out described below.

This appendix lists cables that have been tested and verified for use with the HP 10Base-T Hubs. It also includes minimum pin-out information so, if you wish to use an unlisted cable, you can verify that the cables used in your installation are correctly wired. Note that each pin-out does not necessarily match the pin-out for the corresponding HP cable, but cables manufactured to follow the minimum pin-out will function correctly.

### Minimum Cable Pinout for ASCII Console Connection



# Safety and Regulatory Statements

---

This chapter covers the following topics:

- mounting precautions
  - power precautions
  - safety statements
  - regulatory statements
  - Declaration of Conformity
- 

## Mounting Precautions

When you put a hub into a rack, follow these mounting precautions:

- The rack or cabinet should be adequately secured to prevent it from becoming unstable and/or falling over. The hub should be mounted in a position toward the bottom of the rack for stability and to make it easier to stack the other hubs on top.
- Before mounting a hub, plan its location and orientation relative to other devices and equipment. Also consider the cabling that will be attached to the hub and the ports that will be used. Verify that there is room for the grouped cables to trail out from the side of the hub. Allow at least 2.54 cm (1 inch) in the front of the hub. In the back of the hub, allow at least 3.8 cm (1 1/2 inches) of space for the power cord.
- Ensure that the HP 10Base-T Hub does not overload the power circuits, wiring, and over-current protection. To determine the possibility of overloading the supply circuits, add together the amperage ratings from the nameplates of all your hubs (and other equipment) installed on the same circuits and compare the total with the rating limits for the supply circuits.
- Make sure that the power source circuits are properly grounded, then use the supplied power cord to connect the HP 10Base-T Hubs to the circuit. *See the Safety Statements in this chapter.*
- Do not block airflow around the sides and the back of the unit.

---

**Note**

If your installation requires a different power cord than the one supplied with the hub, be sure to use a power cord displaying the mark of the safety agency that defines the regulations for power cords in your country. The mark is your assurance that the power cord can be used safely with the hub.

---

Do not install the hub in an environment where the operating ambient temperature might exceed 45°C (113°F).

---

## Power Precautions

Follow these precautions when unplugging and plugging in power to the hub as well as adding or removing transceiver modules.

---

**Note**

The hub does not have a power switch; it is powered on when the power cord is plugged in. The hub's power supply automatically adjusts to any AC power source between 100-127 volts and 200-240 volts. There are no voltage range settings to configure.

---

When installing the hub, note that the AC outlet must be installed near the equipment and should be easily accessible.

---

## Safety Information



Documentation reference symbol. If the product is marked with this symbol, refer to the product documentation to get more information about the product.

### WARNING

A **WARNING** in the manual denotes a hazard that can cause injury or death.

### CAUTION

A **CAUTION** in the manual denotes a hazard that can damage equipment.

Do not proceed beyond a **WARNING** or **CAUTION** notice until you have understood the hazardous conditions and have taken appropriate steps.

### Grounding

These are safety class I products and have protective earthing terminals. There must be an uninterruptible safety earth ground from the main power source to the product's input wiring terminals, power cord, or supplied power cord set. Whenever it is likely that the protection has been impaired, disconnect the power cord until the ground has been restored.

For LAN cable grounding:

- If your LAN covers an area served by more than one power distribution system, be sure their safety grounds are securely interconnected.
- LAN cables may occasionally be subject to hazardous transient voltages (such as lightning or disturbances in the electrical utilities power grid). Handle exposed metal components of the network with caution.

### Servicing

There are no user-serviceable parts inside these products. Any servicing, adjustment, maintenance, or repair must be performed only by service-trained personnel.

These products do not have a power switch; they are powered on when the power cord is plugged in.

---

## Informations concernant la sécurité



Symbole de référence à la documentation. Si le produit est marqué de ce symbole, reportez-vous à la documentation du produit afin d'obtenir des informations plus détaillées.

### WARNING

Dans la documentation, un WARNING indique un danger susceptible d'entraîner des dommages corporels ou la mort.

### CAUTION

Un texte de mise en garde intitulé CAUTION indique un danger susceptible de causer des dommages à l'équipement.

Ne continuez pas au-delà d'une rubrique WARNING ou CAUTION avant d'avoir bien compris les conditions présentant un danger et pris les mesures appropriées.

Cet appareil est un produit de classe I et possède une borne de mise à la terre. La source d'alimentation principale doit être munie d'une prise de terre de sécurité installée aux bornes du câblage d'entrée, sur le cordon d'alimentation ou le cordon de raccordement fourni avec le produit. Lorsque cette protection semble avoir été endommagée, débrancher le cordon d'alimentation jusqu'à ce que la mise à la terre ait été réparée.

Mise à la terre du câble de réseau local:

- si votre réseau local s'étend sur une zone desservie par plus d'un système de distribution de puissance, assurez-vous que les prises de terre de sécurité soient convenablement interconnectées.
- Les câbles de réseaux locaux peuvent occasionnellement être soumis à des surtensions transitoires dangereuses (telles que la foudre ou des perturbations dans le réseau d'alimentation public). Manipulez les composants métalliques du réseau avec précautions.

Aucune pièce contenue à l'intérieur de ce produit ne peut être réparée par l'utilisateur. Tout dépannage, réglage, entretien ou réparation devra être confié exclusivement à un personnel qualifié.

Cet appareil ne comporte pas de commutateur principal ; la mise sous tension est effectuée par branchement du cordon d'alimentation.

---

# Hinweise zur Sicherheit



Symbol für Dokumentationsverweis. Wenn das Produkt mit diesem Symbol markiert ist, schlagen Sie bitte in der Produktdokumentation nach, um mehr Informationen über das Produkt zu erhalten.

## WARNING

Symbol für Dokumentationsverweis. Wenn das Produkt mit diesem Symbol markiert ist, schlagen Sie bitte in der Produktdokumentation nach, um mehr Informationen über das Produkt zu erhalten.

## CAUTION

Symbol für Dokumentationsverweis. Wenn das Produkt mit diesem Symbol markiert ist, schlagen Sie bitte in der Produktdokumentation nach, um mehr Informationen über das Produkt zu erhalten.

Fahren Sie nach dem Hinweis WARNING oder CAUTION erst fort, nachdem Sie den Gefahrenzustand verstanden und die entsprechenden Maßnahmen ergriffen haben.

Dies ist ein Gerät der Sicherheitsklasse I und verfügt über einen schützenden Erdungsterminal. Der Betrieb des Geräts erfordert eine ununterbrochene Sicherheitserdung von der Hauptstromquelle zu den Geräteingabeterminals, den Netzkabeln oder dem mit Strom belieferten Netzkabelsatz voraus. Sobald Grund zur Annahme besteht, daß der Schutz beeinträchtigt worden ist, das Netzkabel aus der Wandsteckdose herausziehen, bis die Erdung wiederhergestellt ist.

Für LAN-Kabelerdung:

- Wenn Ihr LAN ein Gebiet umfaßt, das von mehr als einem Stromverteilungssystem beliefert wird, müssen Sie sich vergewissern, daß die Sicherheitserdungen fest untereinander verbunden sind.
- LAN-Kabel können gelegentlich gefährlichen Übergangsspannungen ausgesetzt werden (beispielsweise durch Blitz oder Störungen in dem Starkstromnetz des Elektrizitätswerks). Bei der Handhabung exponierter Metallbestandteile des Netzwerkes Vorsicht walten lassen.

Dieses Gerät enthält innen keine durch den Benutzer zu wartenden Teile. Wartungs-, Anpassungs-, Instandhaltungs- oder Reparaturarbeiten dürfen nur von geschultem Bedienungspersonal durchgeführt werden.

Dieses Gerät hat keinen Netzschalter; es wird beim Anschließen des Netzkabels eingeschaltet.

---

## Considerazioni sulla sicurezza



Simbolo di riferimento alla documentazione. Se il prodotto è contrassegnato da questo simbolo, fare riferimento alla documentazione sul prodotto per ulteriori informazioni su di esso.

### WARNING

La dicitura WARNINGdenota un pericolo che può causare lesioni o morte.

### CAUTION

La dicituraCAUTION denota un pericolo che può danneggiare le attrezzature.

Non procedere oltre un avviso di WARNING o di CAUTIONprima di aver compreso le condizioni di rischio e aver provveduto alle misure del caso.

Questo prodotto è omologato nella classe di sicurezza I ed ha un terminale protettivo di collegamento a terra. Dev'essere installato un collegamento a terra di sicurezza, non interrompibile che vada dalla fonte d'alimentazione principale ai terminali d'entrata, al cavo d'alimentazione oppure al set cavo d'alimentazione fornito con il prodotto. Ogniqualvolta vi sia probabilità di danneggiamento della protezione, disinserite il cavo d'alimentazione fino a quando il collegaento a terra non sia stato ripristinato.

Per la messa a terra dei cavi LAN:

- se la vostra LAN copre un'area servita da più di un sistema di distribuzione elettrica, accertatevi che i collegamenti a terra di sicurezza siano ben collegati fra loro;
- i cavi LAN possono occasionalmente andare soggetti a pericolose tensioni transitorie (ad esempio, provocate da lampi o disturbi nella griglia d'alimentazione della società elettrica); siate cauti nel toccare parti esposte in metallo della rete.

Nessun componente di questo prodotto può essere riparato dall'utente. Qualsiasi lavoro di riparazione, messa a punto, manutenzione o assistenza va effettuato esclusivamente da personale specializzato.

Questo apparato non possiede un commutatore principale; si mette scotto tensione all'inserirsi il cavo d'alimentazione.

---

## Consideraciones sobre seguridad



Símbolo de referencia a la documentación. Si el producto va marcado con este símbolo, consultar la documentación del producto a fin de obtener mayor información sobre el producto.

### WARNING

Una WARNING en la documentación señala un riesgo que podría resultar en lesiones o la muerte.

### CAUTION

Una CAUTION en la documentación señala un riesgo que podría resultar en averías al equipo.

No proseguir después de un símbolo de WARNING o CAUTION hasta no haber entendido las condiciones peligrosas y haber tomado las medidas apropiadas.

Este aparato se enmarca dentro de la clase I de seguridad y se encuentra protegido por una borna de puesta a tierra. Es preciso que exista una puesta a tierra continua desde la toma de alimentación eléctrica hasta las bornas de los cables de entrada del aparato, el cable de alimentación o el juego de cable de alimentación suministrado. Si existe la probabilidad de que la protección a tierra haya sufrido desperfectos, desenchufar el cable de alimentación hasta haberse subsanado el problema.

Puesta a tierra del cable de la red local (LAN):

- Si la LAN abarca un área cuyo suministro eléctrico proviene de más de una red de distribución de electricidad, cerciorarse de que las puestas a tierra estén conectadas entre sí de modo seguro.
- Es posible que los cables de la LAN se vean sometidos de vez en cuando a voltajes momentáneos que entrañen peligro (rayos o alteraciones en la red de energía eléctrica). Manejar con precaución los componentes de metal de la LAN que estén al descubierto.

Este aparato no contiene pieza alguna susceptible de reparación por parte del usuario. Todas las reparaciones, ajustes o servicio de mantenimiento debe realizarlos solamente el técnico.

Este producto no tiene interruptor de potencia; se activa cuando se enchufa el cable de alimentación.

## Safety Information (Japanese)

安全性の考慮

安全記号



マニュアル参照記号。製品にこの記号がついている場合はマニュアルを参照し、注意事項等をご確認ください。

WARNING マニュアル中の「WARNING」は人身事故の原因となる危険を示します。

CAUTION マニュアル中の「CAUTION」は装置破損の原因となる危険を示します。

「WARNING」や「CAUTION」の項は飛ばさないで必ずお読みください。危険性に関する記載事項をよく読み、正しい手順に従った上で次の事項に進んでください。

これは安全性クラス I の製品で保護用接地端子を備えています。主電源から製品の入力配線端子、電源コード、または添付の電源コード・セットまでの間、切れ目のない安全接地が存在することが必要です。もしこの保護回路が損なわれたことが推測されるときは、接地が修復されるまで電源コードを外しておいてください。

LAN ケーブルの接地に関して:

- もし貴社の LAN が複数の配電システムにより電力を受けている領域をカバーしている場合には、それらのシステムの安全接地が確実に相互に結合されていることを確認してください。
- LAN ケーブルは時として危険な過度電圧（例えば雷や、配電設備の電力網での障害）にさらされることがあります。露出した金属部分の取扱いには十分な注意をはらってください。

本製品の内部にはユーザーが修理できる部品はありません。サービス、調整、保守および修理はサービス訓練を受けた専門家におまかせください。

本製品には電源スイッチがありません。電源コードを接続したとき電源入となります。

---

## Regulatory Statements

### FCC Class A Statement (for U.S.A. Only) when using unshielded cables:

This equipment has been tested and found to comply with the limits for a Class A digital device, pursuant to Part 15 of the FCC Rules. These limits are designed to provide reasonable protection against harmful interference when the equipment is operated in a commercial environment. This equipment generates, uses, and can radiate radio frequency energy and, if not installed and used in accordance with the instruction manual, may cause harmful interference to radio communications. Operation of this equipment in a residential area may cause harmful interference in which case the user will be required to correct the interference at his own expense.

If this equipment does cause interference to radio or television reception, which can be determined by turning the equipment off and on, the user is encouraged to try to correct the interference by one or more of the following measures:

- Reorient or relocate the receiving antenna.
- Increase the separation between the equipment and receiver.
- Connect the equipment into an outlet on a circuit different from that to which the receiver is connected.
- Consult the dealer or an experienced radio/TV technician for help.

### VCCI Class 1 (For Japan Only) when using unshielded cables

この装置は、情報処理装置等電波障害自主規制協議会（VCCI）の基準に基づきクラスA情報技術装置です。この装置を家庭環境で使用すると電波妨害を引き起こすことがあります。この場合には使用者が適切な対策を講ずるよう要求されることがあります。

This equipment is in the Class A category information technology equipment based on the rules of Voluntary Control Council For Interference by Information Technology Equipment (VCCI). When used in a residential area, radio interference may be caused. In this case, user may be required to take appropriate corrective actions.

### Canada

This product complies with Class A Canadian EMC requirements when using unshielded cables and Class B EMC requirements.

## Korea

사용자 안내문 : A 급기기

이기는 업무용으로 전자파 적합등록을 받은 기기 이오니, 판매자 또는 사용자는 이점을 주의하시기 바라며, 만약 잘못 구입하셨을 때에는 구입한 곳에서 비업무용으로 교환하시기 바랍니다.

## European Community

This equipment complies with ISO/IEC Guide 22 and EN55022 Class A with unshielded cables and EN55022 Note. With unshielded cables this is a Class A product. In a domestic environment, this product may cause radio interference, in which case the user may be required to take adequate measures.

**DECLARATION OF CONFORMITY**

according to ISO/IEC Guide 22 and EN45014

**Manufacturer's Name:** Hewlett-Packard Company

**Manufacturer's Address:** 8000 Foothills Blvd.  
Roseville, CA 95747-5502  
U.S.A.

**declares that the product:**

**Product Name:** HP 10Base-T Hub 12  
HP 10Base-T Hub 12M  
HP 10Base-T Hub 24  
HP 10Base-T Hub 24M

**Model Number:** HP J3300A, HP J3301A, HP J3302A  
HP J3303A

**Accessories:** HP J2606A, HP J2607A, HP J2608A,  
HP J2609A

**conforms to the following Product Specifications:**

**Safety:** EN60950 (1992)+A1,A2 / IEC 950:1991+A1,A2

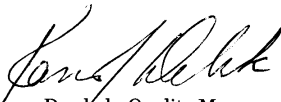
**EMC:** EN 55022 (1994) / CISPR-22 (1993) class A  
EN50082-1 (1992)  
prEN 55024-2 (1992) / IEC 801-2 (1991) 4 kV CD, 8 kV AD  
prEN 55024-3 (1991) / IEC 801-3 (1984), 3 V/m  
prEN 55024-4 (1992) / IEC 801-4 (1988): 1 kV-(power line)  
0.5 kV-(signal line)

**Supplementary Information:**

The product herewith complies with the requirements of the Low Voltage Directive 73/23/EEC and the EMC Directive 89/336/EEC and carries the CE marking accordingly. LEDs in this product(s) are Class-1 in accordance with EN60825-1:1994.

Tested with Hewlett-Packard Co. products only.

Roseville, October 20, 1997

  
Karen Dorchak, Quality Manager

European Contact: Your local Hewlett-Packard Sales and Service Office or Hewlett-Packard GmbH, Department TRE, Herrenberger Strasse 130, D-71034 Böblingen (FAX:+49-7031-14-3143).



---

# Index

## Numerics

50-ohm terminator  
for a ThinLAN cable segment ... 1-12

## A

Activity LED ... 1-4, 2-3, 2-6  
AUI/Xcvr LED ... 2-4

## C

cabinet mounting  
instructions for ... 1-5  
clearing a password ... 2-6  
Collision LED ... 1-4, 2-3, 2-5  
connections  
hub to hub networking ... 1-9  
network ... 1-8  
connector specifications ... A-2  
countries  
power cords for ... 1-2

## D

diagnosing with the LEDs ... 2-2  
diagnostic tests  
testing the hub only ... 2-6

## E

electrical specifications ... A-1  
electromagnetic specifications ... A-2  
environmental specifications ... A-1  
Ethernet networks ... v  
external power supply ... 1-2

## F

Fault LED ... 1-4, 2-3, 2-5  
features  
hub ... vii  
fiber-optic backbone ... 1-12  
firmware enhancements ... 2-8

front of the hub  
status LEDs ... 2-3

## H

HP AdvanceStack SNMP Module  
LED pattern during self-test ... 2-5  
hub  
at a glance ... v  
connecting to fiber-optic backbone ... 1-12  
description ... v  
features ... vii  
mounting ... 1-5  
reference ... 2-3  
troubleshooting ... 2-1  
hub operation  
verifying ... 1-3  
hub to hub network connections  
with the MDI switch ... 1-9

## I

IEEE 802.3 Type 10Base-T standard ... v  
included parts ... 1-2  
installing the hub  
mounting procedures ... 1-5  
network connections ... 1-8  
verifying hub operation ... 1-3  
IP packets, testing ... 2-7

## L

LED pattern ... 1-4  
LEDs  
AUI/Xcvr ... 2-4  
Collision ... 2-3  
diagnosing the hub status ... 2-2  
during self test ... 1-4  
patterns showing error conditions ... 2-5  
Power ... 2-3  
twisted-pair ports ... 2-4  
verifying hub operation ... 1-4  
Link Test ... 2-7  
Link Test, about ... 2-7

list  
included parts ... 1-2

## M

MDI switch  
using ... 1-9  
MDI-X switch  
using ... 1-9  
mounting the hub ... 1-5  
in a rack or cabinet ... 1-5

## N

network connections ... 1-8  
hub to hub connections ... 1-9

## O

out-of-band management  
RS-232 port pin-out ... B-3

## P

parts list ... 1-2  
Password, clearing ... 2-6  
physical specifications of hubs ... A-1  
Ping Test, about ... 2-7  
pin-outs  
minimum cable ... B-4  
Port LED ... 2-4  
Port LEDs ... 1-5, 2-5  
port LEDs  
twisted-pair ... 2-4  
power cord  
plugging into the hub ... 1-3  
plugging into the wall ... 1-3  
Power LED ... 1-4, 2-3, 2-5  
power-on ... 1-4  
procedures  
network connections to the hub ... 1-8

## R

rack mounting ... 1-5  
instructions for ... 1-5  
resetting the hub  
troubleshooting procedure ... 2-6  
RJ-45 jack ... 1-8

## S

Security LED ... 1-4  
Self Test ... 2-5  
Self test  
LED pattern during ... 1-4  
specifications ... A-1  
connectors ... A-2  
electrical ... A-1  
electromagnetic ... A-2  
environmental ... A-1  
physical ... A-1  
status LEDs  
description ... 2-3

## T

table mounting ... 1-6  
terminator  
for a thin LAN segment ... 1-12  
ThinLAN port  
and 50-ohm terminator ... 1-12  
troubleshooting  
approaches ... 2-1  
diagnosing with the LEDs ... 2-2  
LED patterns showing errors ... 2-5  
testing the hub ... 2-6  
twisted-pair cable  
hub-to-computer connection ... B-1  
pin assignments ... B-3  
twisted-pair ports  
LED description ... 2-4

## V

verifying hub operation ... 1-3

Technical information in this document  
is subject to change without notice.

©Copyright Hewlett-Packard Company  
1997. All rights reserved. Reproduction,  
adaptation, or translation without prior  
written permission is prohibited except  
as allowed under the copyright laws.

---

Printed in Singapore 11/97

Manual Part Number  
5967-0852

