



Installation and
Getting Started Guide

ProCurve Switch zl
Power Supply Shelf



Power over Ethernet Devices

ProCurve Switch zl
Power Supply Shelf

Installation and Getting Started Guide

© Copyright 2007, Hewlett-Packard Development Company, L.P. The information contained herein is subject to change without notice.

This document contains proprietary information, which is protected by copyright. No part of this document may be photocopied, reproduced, or translated into another language without the prior written consent of Hewlett-Packard.

Publication Number

5991-4739
February 2007

Applicable Products

ProCurve Switch zl Power Supply Shelf	(J8714A)
ProCurve Switch zl Internal Power Supply	(J8712A)
ProCurve Switch zl 220V Internal Power Supply	(J8713A)
ProCurve Switch 5406zl	(J8697A)
ProCurve Switch 5406zl-48G	(J8699A)
ProCurve Switch 5412zl	(J8698A)
ProCurve Switch 5412zl-96G	(J8700A)

Disclaimer

HEWLETT-PACKARD COMPANY MAKES NO WARRANTY OF ANY KIND WITH REGARD TO THIS MATERIAL, INCLUDING, BUT NOT LIMITED TO, THE IMPLIED WARRANTIES OF MERCHANTABILITY AND FITNESS FOR A PARTICULAR PURPOSE. Hewlett-Packard shall not be liable for errors contained herein or for incidental or consequential damages in connection with the furnishing, performance, or use of this material.

The only warranties for HP products and services are set forth in the express warranty statements accompanying such products and services. Nothing herein should be construed as constituting an additional warranty. HP shall not be liable for technical or editorial errors or omissions contained herein.

Hewlett-Packard assumes no responsibility for the use or reliability of its software on equipment that is not furnished by Hewlett-Packard.

Warranty

See the Customer Support/Warranty booklet included with the product.

A copy of the specific warranty terms applicable to your Hewlett-Packard products and replacement parts can be obtained from your HP Sales and Service Office or authorized dealer.

Safety

Before installing and operating these products, please read the “Installation Precautions” in chapter 2, “Installing and Connecting the ProCurve Switch zl Power Supply Shelf”, and the safety statements in appendix B, “Safety and Regulatory Statements”.

Contents

1 Introducing the ProCurve Switch zl Power Supply Shelf

Front of the Unit	1-2
LEDs	1-3
Back of the Unit	1-4
EPS Ports on the Power Supply Shelf	1-4
Port Status LEDs	1-4
Power Connector	1-4
EPS Port Operation	1-5
Supported Switches	1-5

2 Installing and Connecting the External Power Supply Shelf

Included Parts	2-1
Installation Procedures	2-2
Summary	2-2
Installation Precautions:	2-3
1. Prepare the Installation Site	2-4
2. Mount the Unit	2-4
Rack or Cabinet Mounting	2-4
Horizontal Surface Mounting	2-7
3. Install the Power Supplies	2-8
4. Connect the Power Supply Shelf to a Switch	2-9
Connecting EPS Ports to Switches	2-9
5. Connect AC Power	2-10
6. Verify Correct Operation	2-11
Recommended Connection Topologies	2-12
Limitations	2-12
Status Indication	2-12
Limitations	2-13
UPS Support	2-13

3 Troubleshooting

Basic Troubleshooting Tips	3-1
Diagnosing with the LEDs	3-2
Diagnostic Tests	3-4
Testing the Unit by Resetting It	3-4
Checking the Unit's LEDs	3-4
Testing Cabling	3-4
HP Customer Support Services	3-4

A Specifications

Physical	A-1
Electrical	A-1
Environmental	A-1
Acoustic	A-2
Cable Length	A-2
Safety	A-2
EMC Compliance (Class A)	A-2
Immunity	A-2

B Safety and Regulatory Statements

Safety Information	B-1
Informations concernant la sécurité	B-2
Hinweise zur Sicherheit	B-3
Considerazioni sulla sicurezza	B-4
Consideraciones sobre seguridad	B-5
Safety Information (Japan)	B-6
Safety Information (China)	B-7
EMC Regulatory Statements	B-8
U.S.A.	B-8
Canada	B-8

Australia/New Zealand B-8
Japan B-8
Korea B-9
Taiwan B-9
Declaration of Conformity B-10
Regulatory Information (China) B-11

C Recycle Statements

Waste Electrical and Electronic Equipment (WEEE) Statements C-1

Index

Introducing the ProCurve Switch zl Power Supply Shelf

The ProCurve Switch zl Power Supply Shelf is an external power supply that can supply backup or extra Power over Ethernet (PoE) power to the Series zl Switches.

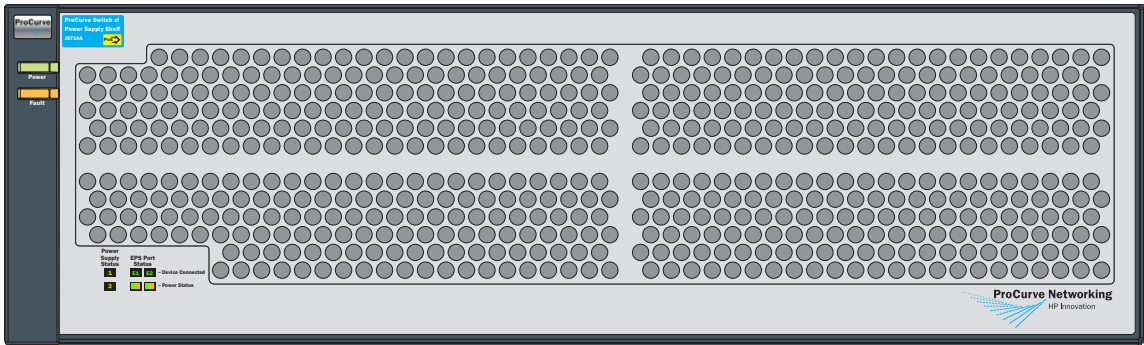

Figure 1-1. ProCurve Switch zl Power Supply Shelf (J8714A)

Throughout this manual, this unit will be abbreviated as the Power Supply Shelf.

The Power Supply Shelf has two external power supply (EPS) ports that provide PoE power for a connected ProCurve zl switch.

This chapter describes the Power Supply Shelf including:

- front of the unit (page 1-2)
- back of the unit (page 1-4)
- EPS port operation (page 1-5)
- supported switches (page 1-5)

Front of the Unit

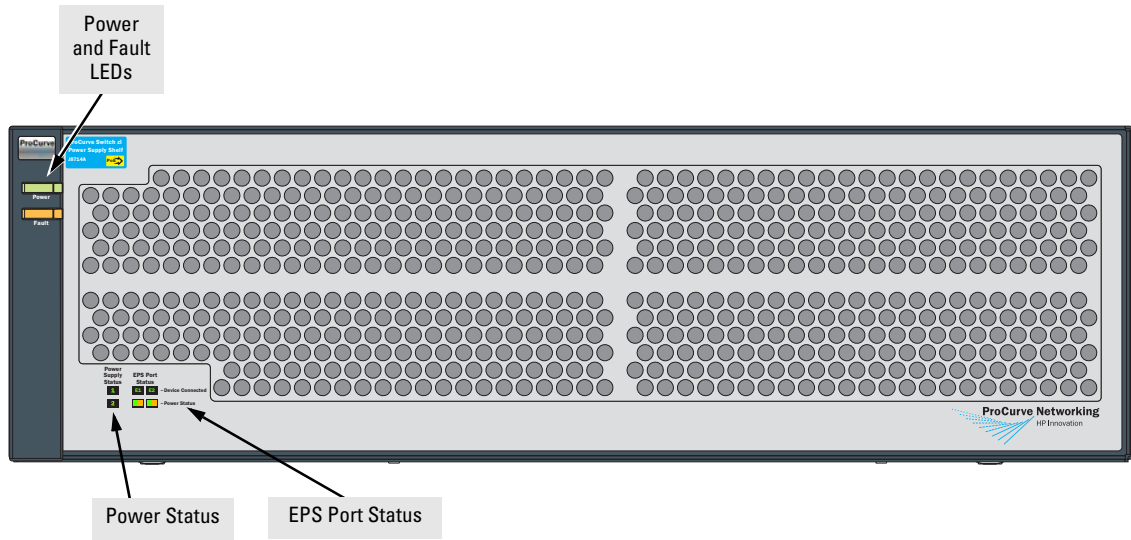

Figure 1-2. Front of zl Power Supply Shelf

LEDs

Table 1-1. Power Supply Shelf LEDs

LED	State	Meaning
Power (green) Also on back panel of the Power Supply Shelf	On	The unit is powered on.
	Off	The unit is NOT powered on.
Fault (orange) Also on back panel of the Power Supply Shelf	Off	The normal state; indicates there are no fault conditions on the unit.
	Flash orange ^{1,3}	A fault has occurred on the unit, one of the ports. The Status LED for the component with the fault will Flash simultaneously.
	On	On briefly after the unit is powered on or reset. If this LED is on for a prolonged time, the unit has encountered a fatal hardware failure. See chapter 3, "Troubleshooting" for more information.
Power Supply Status (green and orange)	On	The power supply is plugged in and functional.
	Off	No power supply is present.
	Flash orange ^{1,3}	The power supply has a fault or has been unplugged.
Port Status (also on back panel of the Power Supply Shelf)		
Device Connected (green – over-laid with the port number)	On	There is a valid connection to a device.
	Off	There is no valid device connected to the port.
Power Status (green and orange)	On	The unit is supplying power to a connected device.
	Off	One of these conditions exists: <ul style="list-style-type: none"> • There is no device connected. • A connected device is not valid.
	Flash orange ¹	When the LED is flashing simultaneously with the Fault LED, there is a fault condition on the port.
¹ The flashing behavior is an on/off cycle once every 1.6 seconds, approximately. ² The flashing behavior is an on/off cycle once every 1.6 seconds, approximately. ³ Specific fault conditions can be viewed by checking switch log files.		

Back of the Unit

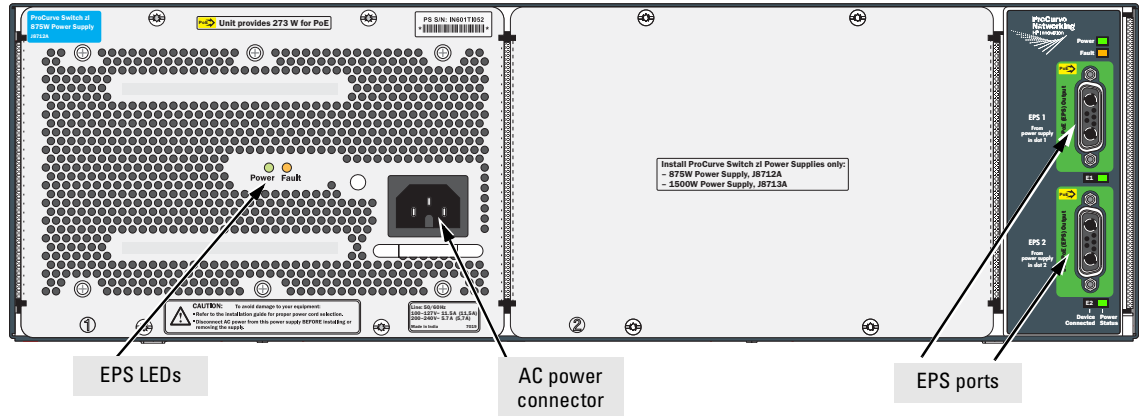

Figure 1-3. Back of zl Power Supply Shelf

EPS Ports on the Power Supply Shelf

The Power Supply Shelf has two external power supply ports. You can connect one or two ProCurve zl PoE capable switches to provide PoE power as a primary or backup source. Each port receives the maximum power, depending on which power supply is installed, either 273 W or 900 W. Each EPS port is independent of the other, if one of the power supplies fails the other can still provide EPS power.

Port Status LEDs

The EPS port status LEDs on the Power Supply Shelf back panel are a duplication of those on the front panel. For a description of these LEDs, see Table 1-1 on page 1-3.

Power Connector

The Power Supply Shelf does not have a power switch; it is powered on when connected to an active AC power source. The power supply J8712A automatically adjusts to any voltage between 100-127 and 200-240 volts and either 50 or 60 Hz. The power supply J8713A only operates at 200-240 volts and either 50 or 60 Hz. There are no voltage range settings required.

EPS Port Operation

The Power Supply Shelf supports two EPS ports that can provide power to PoE capable zl switches through EPS cables. Each external power supply unit can provide additional or redundant PoE power to a zl switch. All internal power supplies have PoE power.

Each EPS port operates individually. The Power Supply Shelf has two EPS ports that can provide maximum power, depending on which power supply is installed, either 273 W or 900 W of PoE power at 50 VDC each. See “Recommended Connection Topologies” on page 2-12.

Supported Switches

Switch	Product Number
ProCurve Switch 5406zl	J8697A
ProCurve Switch 5412zl	J8698A

Installing and Connecting the External Power Supply Shelf

The Power Supply Shelf comes with an accessory kit that includes the brackets for mounting the unit in a standard 19-inch telco rack or in an equipment cabinet, and rubber feet that can be attached so the unit can be securely located on a horizontal surface. The brackets are designed to allow mounting the unit in a variety of locations and orientations.

This chapter shows you how to install the Power Supply Shelf including:

- included parts (page 2-1)
 - installation procedures (page 2-2)
 - recommended connection topologies (page 2-12)
-

Included Parts

The Power Supply Shelf has the following components shipped with them:

- *ProCurve Switch zl Power Supply Shelf Installation and Getting Started Guide*, this manual
- *ProCurve Power over Ethernet (PoE) for zl and yl Products Planning and Implementation Guide*
- Read Me First
- Customer Support/Warranty booklet (5991-6261)
- Accessory kit

(5070-3028)

- two mounting brackets
 - eight 8-mm M4 screws to attach the mounting brackets to the unit
 - four 5/8-inch number 12-24 screws to attach the unit to a rack
 - four rubber feet
-

- Two EPS cables, (5070-0102)
-

Installation Procedures

Summary

Follow these steps to install the Power Supply Shelf. The rest of this chapter provides details on these steps.

1. **Prepare the installation site** (page 2-4). Make sure the physical environment into which the unit will be installed is properly prepared, including having the correct cabling ready to connect to the unit and having an appropriate location for the unit. See page 2-3 for installation precautions.
2. **Mount the unit** (page 2-4). The unit can be mounted in a 19-inch telco rack, in an equipment cabinet, or on a horizontal surface.
3. **Install the power supplies** (page 2-8). The Power Supply Shelf does not come with power supplies. You must purchase them separately and install them.
4. **Connect the Power Supply Shelf to a switch** (page 2-9). Using the supplied EPS cables, connect the unit to the devices that it will support.
5. **Connect AC power to the unit** (page 2-10). Once the unit is mounted, plug it into a nearby main AC power source.
6. **Verify the unit is operating correctly** (page 2-11). This is a simple process of observing that the LEDs on the unit's front panel indicate correct operation.

At this point, your unit is fully installed. See the rest of this chapter if you need more detailed information on any of these installation steps.

Installation Precautions:

Follow these precautions when installing your Power Supply Shelf:

WARNINGS

- **The rack or cabinet should be adequately secured to prevent it from becoming unstable and/or falling over.**
Devices installed in a rack or cabinet should be mounted as low as possible, with the heaviest devices at the bottom and progressively lighter devices installed above.
- **Ensure a cover plate is installed on any empty switch power supply slot. A cover plate is required for safe operations, and to ensure proper switch cooling.**

Cautions

- Make sure the power source circuits are properly grounded, then use the power cord supplied with the unit to connect it to the power source.
- If your installation requires a different power cord than the one supplied with the unit, be sure to use a power cord displaying the mark of the safety agency that defines the regulations for power cords in your country. The mark is your assurance the power cord can be used safely with the unit.
- When installing the unit, note that the AC outlet should be near the unit and should be easily accessible in case the unit must be powered off.
- Ensure the unit does not overload the power circuits, wiring, and over-current protection. To determine the possibility of overloading the supply circuits, add together the ampere ratings of all devices installed on the same circuit as the unit and compare the total with the rating limit for the circuit. The maximum ampere ratings are usually printed on devices near the AC power connectors.
- Do not install the unit in an environment where the operating ambient temperature might exceed 55°C (131°F).
- Make sure the air flow around the front, sides and back of the unit is not restricted. If this unit is placed in a fully enclosed rack, make certain the ambient temperature inside the rack near the unit does not exceed 55°C (131°F).
- For safe operation and to prevent equipment damage, DO NOT connect EPS, or power cables to non-supported equipment or in non-supported configurations.

1. Prepare the Installation Site

- **Cabling** - Only use the EPS cables supplied with the unit for external power connections to switches.
- **Installation Location** - Before installing the unit, plan its location and orientation relative to other devices and equipment:
 - In both the front and back of the unit, leave at least 7.6 cm (3 inches) of space for the EPS cables, and the power cord.
 - On the sides of the unit, leave at least 7.6 cm (3 inches) for cooling.

2. Mount the Unit

The Power Supply Shelf can be mounted in these ways:

- in a rack or cabinet
- on a horizontal surface

Rack or Cabinet Mounting

The Power Supply Shelf is designed to be mounted in any EIA-standard 19-inch telco rack or communication equipment cabinet. The mounting brackets have multiple mounting holes and can be rotated allowing for a wide variety of mounting options.

WARNING

For safe operation, please read the installation precautions on page 2-3, before mounting the unit.

Equipment Cabinet Note

The 12-24 screws supplied with the unit are the correct threading for standard EIA/TIA open 19-inch racks. If you are installing the unit in an equipment cabinet such as a server cabinet, use the clips and screws that came with the cabinet in place of the 12-24 screws that are supplied with the unit.

1. Use a #1 Phillips (cross-head) screwdriver and attach the mounting brackets to the unit with the included 8-mm M4 screws. The screws must be tightened sufficiently to provide proper support for the unit in the rack.



Figure 2-1. Attaching brackets to the unit

WARNING

For safe reliable installation, only use the screws provided in the accessory kit to attach the mounting brackets to the unit.

Note

The mounting brackets have multiple mounting holes and can be rotated allowing for a wide variety of mounting options. These include mounting the unit so that its front face is flush with the face of the rack as shown in the illustration above. Be sure not to block the side vent holes.

2. Partially install a screw into the top hole of a pair of holes that are 0.5 inches apart in each rack/cabinet upright as shown in the illustration below. Ensure that the screws are at the same level in each upright.

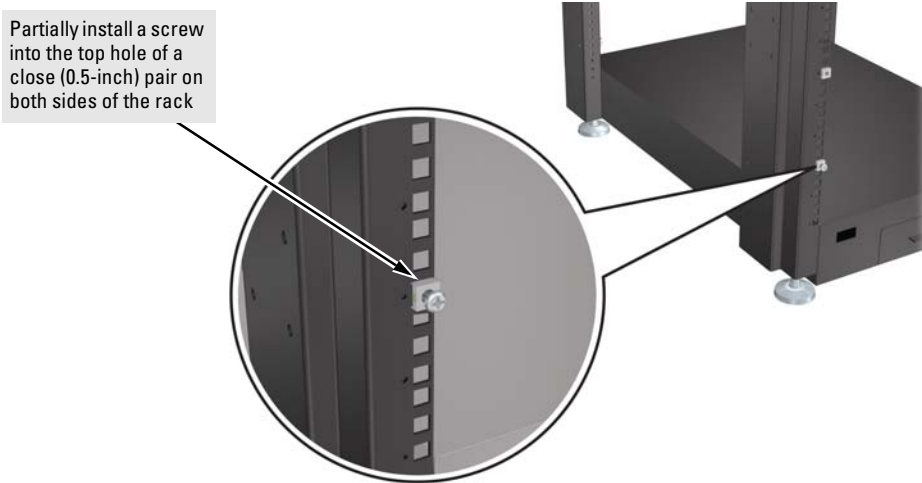

Figure 2-2. Mounting screw positioning

3. Place the switch in the rack and lower it so the notches in the bottom of the bracket slide onto the screws, then tighten these screws.

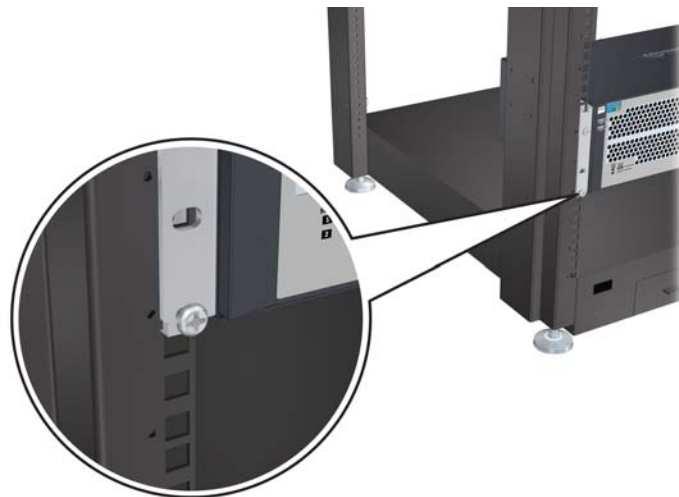

Figure 2-3. Installing bracket notches on screw

4. Install the other screw into the upper hole in each bracket. Tighten these screws.



Figure 2-4. Installing top screws into bracket and rack

Horizontal Surface Mounting

Place the unit on a table or other horizontal surface. The unit comes with rubber feet in the accessory kit that can be used to help keep the unit from sliding on the surface.

Attach the rubber feet to the four corners on the bottom of the unit within the embossed angled lines. Use a sturdy surface in an uncluttered area. You may want to secure the EPS cables and the unit's power cord to the table leg or other part of the surface structure to help prevent tripping over the cords.

Caution

Make sure the air flow is not restricted around the front, sides or back of the unit.

3. Install the Power Supplies

The Power Supply Shelf does not come with power supplies installed. You must purchase power supplies separately and install them. The supported power supplies are the:

- ProCurve Switch zl Internal Power Supply, J8712A
 - ProCurve Switch zl 220V Internal Power supply, J8713A
1. Remove the power supply slot cover if present.
 2. Slide the power supply into the slot.
 3. Secure the power supply by tightening the retaining screws.



Figure 2-5. Installing a power supply

Note

Although mixing power supplies is supported, ProCurve Networking highly recommends that the two types of power supplies are not mixed in the same Power Supply Shelf.

See the *Procurve Power over Ethernet (PoE) for zl and yl Products Planning and Implementation Guide*, page 4-9 for more information.

4. Connect the Power Supply Shelf to a Switch

Connect the EPS cables from the supported network switches to the appropriate ports on the Power Supply Shelf. Also see “Recommended Connection Topologies” on page 2-12.

Connecting EPS Ports to Switches

To connect:

Push the EPS cable plug into the desired port until the thumb screws engage with the screw holes in the unit. Tighten the thumb screws.

Always attach the EPS cable to the connector that is associated with an installed power supply. For example, if there is a power supply installed in slot 1, connect the EPS cable to EPS 1.

When power is on for the Power Supply Shelf and for the connected switch, the Device Connected LED should go on to confirm a powered-on switch is at the other end of the cable.

If the Device Connected LED does *not* go on when the cable is connected to the port, see Diagnosing with the LEDs in chapter 3, “Troubleshooting.”

To disconnect:

Unscrew the thumb screws on the plug and pull the plug out of the port.

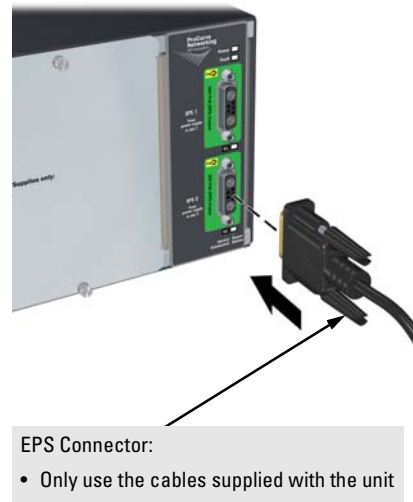

Caution

Disconnecting the EPS (PoE power) cable with power flowing is not supported, and could cause loss of PoE power to all network devices connected to the switch. The Power Supply Shelf must be powered down before disconnecting the EPS (PoE power) cable, if power is flowing. Only the power supply to be disconnected must be powered down. The EPS cable may be connected at any time.

Note

Refer to “EPS Port Operation” on page 1-5 for detailed information and on PoE power usage, and to “Limitations” on page 2-13 for information on maximum available PoE power.

5. Connect AC Power

Connect the AC power cord supplied with the Power Supply Shelf to the power connector on the back of the unit, and then into a properly grounded electrical outlet.

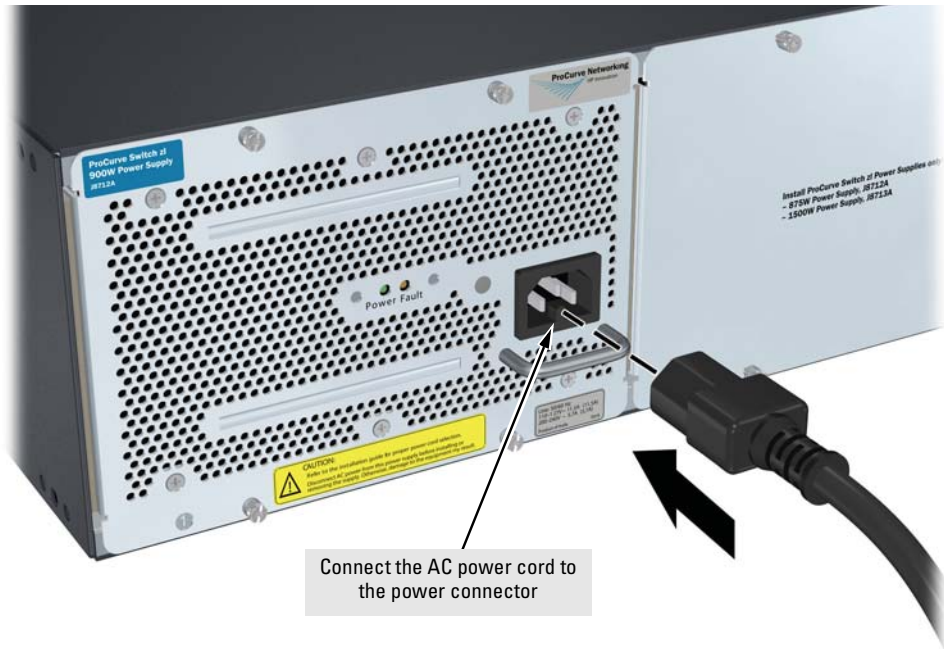

Figure 2-6. Connecting AC power

The Power Supply Shelf does not have a power switch. They are powered on when the power cord is connected to the unit and to a power source. For safety, the power outlet should be located near the unit installation.

The power supply J8712A automatically adjusts to any voltage between 100-127 and 200-240 volts and either 50 or 60 Hz. The power supply J8713A only operates at 200-240 volts and either 50 or 60 Hz. There are no voltage range settings required.

If your installation requires a different power cord than the one supplied with the unit, be sure the cord is adequately sized for the unit's current requirements. In addition, be sure to use a power cord displaying the mark of the safety agency that defines the regulations for power cords in your country. The mark is your assurance that the power cord can be used safely with the unit.

6. Verify Correct Operation

When the Power Supply Shelf is mounted in its location and powered on, you should first verify it is working properly by checking the unit's LEDs.

Check the LEDs on the unit as described below.

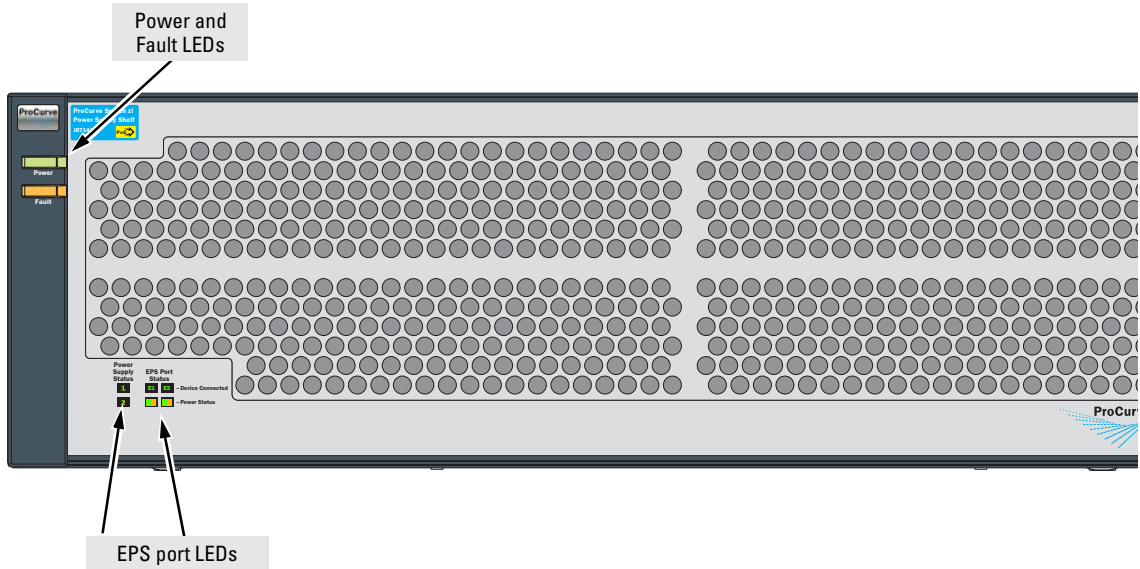

Figure 2-7. Verifying correct operation

When the unit is powered on, all LEDs will light up briefly (approximately 8 seconds) then go off except for the power LED, it should remain on.

Recommended Connection Topologies

This section shows some recommended connection topologies using the Power Supply Shelf. The Power Supply Shelf provides only EPS (PoE) power for up to two ProCurve switches. In the illustration below, one Power Supply Shelf with two power supplies is connected to a ProCurve Series zl Switch, also with two power supplies. The switch provides PoE power to Ethernet devices connected to their ports.

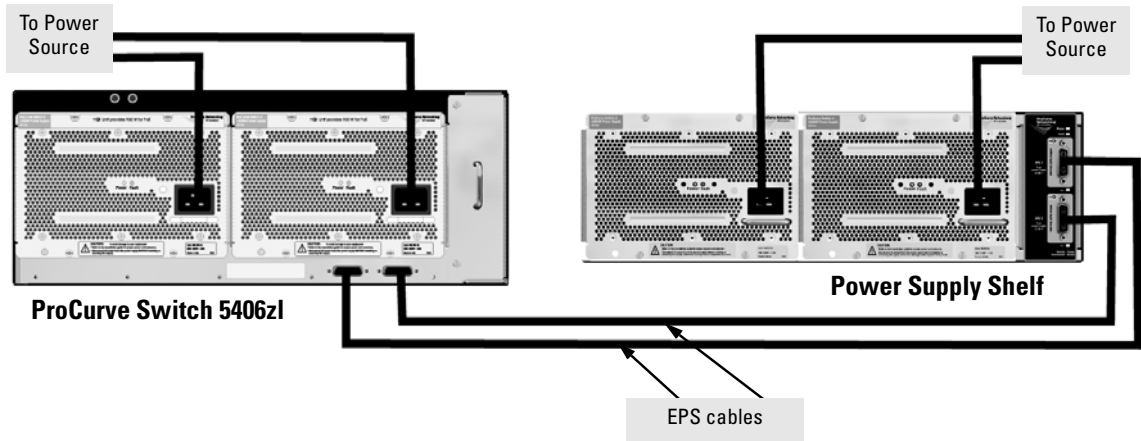

Figure 2-8. Connecting the EPS to one 5406zl switch

Limitations

The Power Supply Shelf supplies only PoE power.

Status Indication

The Power Status LEDs on the Power Supply Shelf indicate if a port can provide power. For example, if two switches are connected to the Power Supply Shelf and the power to the switch on port 2 fails, the Power Status LED for port 2 turns on. The Power Status LED for port 1 remains off.

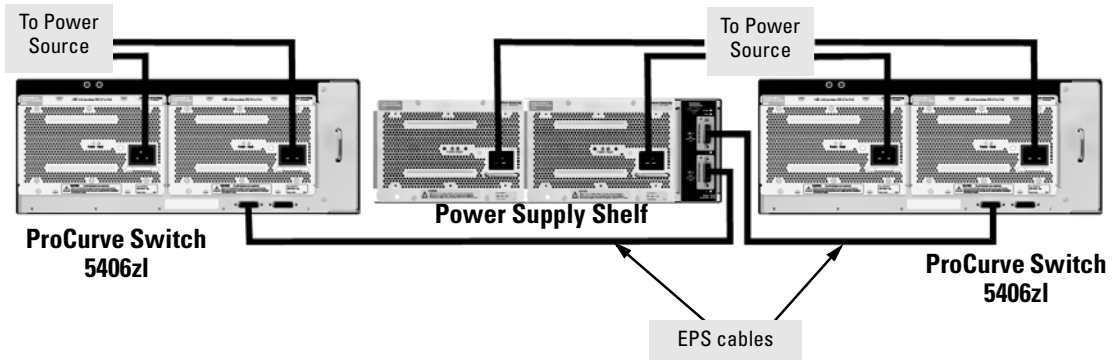

Figure 2-9. Connecting one EPS to two 5406zl switches

Limitations

In the illustration above, the maximum power that can be provided to each switch is dependant upon which power supply is installed in the Power Supply Shelf.

UPS Support

The Power Supply Shelf may be used in configurations where an Uninterruptible Power Supply (UPS) is desired. See Appendix A, “Specifications,” for the power requirements of the Power Supply Shelf for use in determining your UPS requirements.

Troubleshooting

This chapter describes how to troubleshoot the Power Supply Shelf.

This chapter describes the following:

- basic troubleshooting tips (page 3-1)
 - diagnosing with the LEDs (page 3-2)
 - diagnostic tests (page 3-4)
 - HP customer support services (page 3-4)
-

Basic Troubleshooting Tips

Most problems are caused by the following situations. Check for these items first when starting your troubleshooting:

- **Faulty or loose cables.** Look for loose or obviously faulty connections. If the cables appear to be OK, make sure the connections are secure. If that does not correct the problem, try a different cable.
- **Connection topologies.** It is important to make sure you have a valid connection topology. The Power Supply Shelf can support two ProCurve PoE devices. Sample topologies are shown at the end of chapter two page 2-12 in this book.
- **Power limitations.** Be sure to understand the power limitations of the Power Supply Shelf when connecting switches. An overload condition on a port causes the port to be shut down.

Note

Use caution when power cycling the Power Supply Shelf as this may affect devices receiving PoE power from the unit.

Diagnosing with the LEDs

Table 3-1 shows LED patterns on the Power Supply Shelf that indicate problem conditions.

1. Check in the table for the LED pattern that you see on your unit.
2. Refer to the corresponding diagnostic tip on the next few pages.

Table 3-1. LED Error Indicators

LED Pattern Indicating Problems				Diagnostic Tips
Power	Fault	Device Connected	Power Status	
Off with power cord plugged in	1	1	1	❶
On	Prolonged On	1	1	❷
On	Flashing ²	1	1	❸
On	Flashing ²		Flashing ²	❹
On	Off	Off with cable connected	Off	❺
On	Off	On with cable connected	Off ³ (EPS port only)	❻

¹ This LED is not important for the diagnosis.
² The flashing behavior is an on/off cycle once every 1.6 seconds, approximately.
³ Check the log file of the connected switch for a message on the fault.

Diagnostic Tips:

Tip	Problem	Solution
1	The unit is not plugged into an active AC power source, or the unit's power supply may have failed.	<ol style="list-style-type: none"> 1. Verify the power cord is plugged into an active power source and to the unit. Make sure these connections are snug. 2. Try power cycling the unit by unplugging and plugging the power cord back in. 3. If the Power LED is still not on, verify that the AC power source works by plugging another device into the outlet. Or try plugging the unit into a different outlet or try a different power cord. <p>If the power source and power cord are OK and this condition persists, the unit's power supply may have failed. Call your HP-authorized LAN dealer, or use the electronic support services from HP to get assistance. See the Customer Support/Warranty booklet for more information.</p>
2	A hardware failure has occurred. All the LEDs will stay on indefinitely.	Try power cycling the unit. If the fault indication reoccurs, the unit may have failed. Call your HP-authorized LAN dealer, or use the electronic support services from HP to get assistance. See the Customer Support/Warranty booklet for more information.
3	The unit has experienced a failure.	Try resetting the unit by power cycling the unit. If necessary to resolve the problem, contact your HP-authorized LAN dealer, or use the electronic support services from HP to get assistance. See the Customer Support/Warranty booklet for more information.
4	The port for which the LED is flashing has experienced a failure.	An over-current condition may have been caused by a connected device. Unplug the cable connected to the port, then plug it back in. If the condition returns, carefully power cycle the unit (be careful that other devices connected to the unit will not be adversely affected). If the fault indication reoccurs, the unit port may have failed. Call your HP-authorized LAN dealer, or use the electronic support services from HP to get assistance. See the Customer Support/Warranty booklet for more information.
5	The connection is not working properly.	Try the following procedures: <ul style="list-style-type: none"> • For the indicated port, verify that both ends of the cabling, at the unit and the connected device, are connected properly. • Verify the connected device and unit are both powered <i>on</i> and operating correctly. • If the other procedures don't resolve the problem, try using a different port or a different cable.
6	EPS power is not available.	Check the log file of the connected switch for more detailed information. Try disconnecting, then reconnecting the EPS cable. Wait three to four seconds for the device to successfully communicate for EPS power. Also try another EPS cable. If this fails to restore EPS power, call your HP-authorized LAN dealer, or use the electronic support services from HP to get assistance. See the Customer Support/Warranty booklet for more information.

Diagnostic Tests

Testing the Unit by Resetting It

If you believe the Power Supply Shelf is not operating correctly, you can reset the unit to test its circuitry and operating code. To reset a unit, unplug and plug in the power cord (power-cycling).

Caution

Use caution when power cycling the unit as this may affect devices receiving operating power from the unit.

Power-cycling the Power Supply Shelf causes the unit to perform its power-on self test, which normally resolves any temporary operational problems.

Checking the Unit's LEDs

The self test passes if the Fault LED on the front of the Power Supply Shelf goes off after approximately 8 seconds. If this LED stays on longer than 15 seconds or begins flashing, there may be a problem with the unit.

See “Diagnosing with the LEDs” on page 3-2 for information on interpreting the LED patterns.

Testing Cabling

EPS cables that fail to provide a link or provide an unreliable link between the unit and the connected device may be faulty. To verify your cable, try using it to connect to a device that is known to operate correctly or try using a different port. If the problem persists, replace it with another cable.

HP Customer Support Services

If you are still having trouble with your Power Supply Shelf, Hewlett-Packard offers support 24 hours a day, seven days a week through a number of automated electronic services. See the Customer Support/Warranty booklet that came with your Power Supply Shelf for information on how to use these services to get technical support. The ProCurve Web site, www.procurve.com also provides up-to-date support information under “product support”.

Additionally, your HP-authorized network reseller can provide you with assistance, both with services they offer and with services offered by HP.

Specifications

Physical

	Power Supply Shelf
Width:	44.3 cm (17.4 in)
Depth:	22.76 cm (8.96 in)
Height:	13.22 cm (5.2 in)
Weight:	4.2 kg (9.2 lbs)

Electrical

The Power Supply Shelf automatically adjusts to any voltage between 100-127 and 200-240 volts when using the J8712A power supply, and 200-240 volts only when using the J8713A power supply, and either 50 or 60 Hz.

	J8712A	J8713A
AC voltage:	100–127 volts	200–240 volts
Maximum current:	12 A	5 A
Frequency range:	50/60 Hz	50/60 Hz
Maximum continuous output power:	875W	875W

Note

Typical input current for each of the two power supplies when installed in the Power Supply Shelf is approximately 5A@ 100-127V~ and 2.5A@ 200-240V for J8712A and 6.4A@ 200-240V~ for J8713A.

Environmental

	Power Supply Shelf
Operating Temperature:	0°C to 55°C (32°F to 131°F)
Non-Operating Temperature	-40°C to 70°C (-40°F to 158°F)
Operating Relative humidity: (non-condensing)	15% to 95% at 40°C (104°F)

Non-Operating Relative humidity: (non-condensing) 90% maximum at 65°C (149°F)

Maximum altitude: 3.5 Km (10,000 ft)

Acoustic

Power Supply Shelf

Geraeuschemission LwA=52.9 dB am fiktiven Arbeitsplatz nach DIN 45635 T.19

Noise Emission LwA=52.9 dB at virtual workspace according to DIN 45635 T.19

Cable Length

EPS cables are 2.0 meters (6.56 feet) in length

Safety

Complies with:

- EN60950 / IEC 60950
- CSA 22.2 No. 60950
- UL 60950

EMC Compliance (Class A)

Complies with:

- FCC Part 15.107
- ICES-003 (Canada)
- VCCI
- CISPR-22

Immunity

- CISPR-24

Safety and Regulatory Statements

Safety Information



Documentation reference symbol. If the product is marked with this symbol, refer to the product documentation to get more information about the product.

WARNING

A **WARNING** in the manual denotes a hazard that can cause injury or death.

Caution

A Caution in the manual denotes a hazard that can damage equipment.

Do not proceed beyond a **WARNING** or Caution notice until you have understood the hazardous conditions and have taken appropriate steps.

Grounding

This product is a safety class I compliant product and has a protective earthing terminal. There must be an uninterruptible safety earth ground from the main power source to the product's power cord or supplied power cord set. Whenever it is likely that the protection has been impaired, disconnect the power cord until the ground has been restored.

For LAN cable grounding:

- If your LAN covers an area served by more than one power distribution system, be sure their safety grounds are securely interconnected.
- LAN cables may occasionally be subject to hazardous transient voltages (such as lightning or disturbances in the electrical utilities power grid). Handle exposed metal components of the network with caution.

Servicing

There are no user-serviceable parts inside this product. Any servicing, adjustment, maintenance, or repair must be performed only by service-trained personnel.

This product does not have a power switch; it is powered on when the power cord is plugged in.

Informations concernant la sécurité



Symbole de référence à la documentation. Si le produit est marqué de ce symbole, reportez-vous à la documentation du produit afin d'obtenir des informations plus détaillées.

WARNING

Dans la documentation, un **WARNING** indique un danger susceptible d'entraîner des dommages corporels ou la mort.

Caution

Un texte de mise en garde intitulé Caution indique un danger susceptible de causer des dommages à l'équipement.

Ne continuez pas au-delà d'une rubrique **WARNING** ou Caution avant d'avoir bien compris les conditions présentant un danger et pris les mesures appropriées.

Cet appareil est un produit de classe I et possède une borne de mise à la terre. La source d'alimentation principale doit être munie d'une prise de terre de sécurité installée aux bornes du câblage d'entrée, sur le cordon d'alimentation ou le cordon de raccordement fourni avec le produit. Lorsque cette protection semble avoir été endommagée, débrancher le cordon d'alimentation jusqu'à ce que la mise à la terre ait été réparée.

Mise à la terre du câble de réseau local:

- si votre réseau local s'étend sur une zone desservie par plus d'un système de distribution de puissance, assurez-vous que les prises de terre de sécurité soient convenablement interconnectées.
- Les câbles de réseaux locaux peuvent occasionnellement être soumis à des surtensions transitoires dangereuses (telles que la foudre ou des perturbations dans le réseau d'alimentation public). Manipulez les composants métalliques du réseau avec précautions.

Aucune pièce contenue à l'intérieur de ce produit ne peut être réparée par l'utilisateur. Tout dépannage, réglage, entretien ou réparation devra être confié exclusivement à un personnel qualifié.

Cet appareil ne comporte pas de commutateur principal ; la mise sous tension est effectuée par branchement du cordon d'alimentation.

Hinweise zur Sicherheit



Symbol für Dokumentationsverweis. Wenn das Produkt mit diesem Symbol markiert ist, schlagen Sie bitte in der Produktdokumentation nach, um mehr Informationen über das Produkt zu erhalten.

WARNING

Eine **WARNING** in der Dokumentation symbolisiert eine Gefahr, die Verletzungen oder sogar Todesfälle verursachen kann.

Caution

Caution in der Dokumentation symbolisiert eine Gefahr, die das Gerät beschädigen kann.

Fahren Sie nach dem Hinweis **WARNING** oder Caution erst fort, nachdem Sie den Gefahrezustand verstanden und die entsprechenden Maßnahmen ergriffen haben.

Dies ist ein Gerät der Sicherheitsklasse I und verfügt über einen schützenden Erdungsterminal. Der Betrieb des Geräts erfordert eine ununterbrochene Sicherheitserdung von der Hauptstromquelle zu den Geräteingabeterminals, den Netzkabeln oder dem mit Strom belieferten Netzkabelsatz voraus. Sobald Grund zur Annahme besteht, daß der Schutz beeinträchtigt worden ist, das Netzkabel aus der Wandsteckdose herausziehen, bis die Erdung wiederhergestellt ist.

Für LAN-Kabelerdung:

- Wenn Ihr LAN ein Gebiet umfaßt, das von mehr als einem Stromverteilungssystem beliefert wird, müssen Sie sich vergewissern, daß die Sicherheitserdungen fest untereinander verbunden sind.
- LAN-Kabel können gelegentlich gefährlichen Übergangsspannungen ausgesetzt werden (beispielsweise durch Blitz oder Störungen in dem Starkstromnetz des Elektrizitätswerks). Bei der Handhabung exponierter Metallbestandteile des Netzwerkes Vorsicht walten lassen.

Dieses Gerät enthält innen keine durch den Benutzer zu wartenden Teile. Wartungs-, Anpassungs-, Instandhaltungs- oder Reparaturarbeiten dürfen nur von geschultem Bedienungspersonal durchgeführt werden.

Dieses Gerät hat keinen Netzschalter; es wird beim Anschließen des Netzkabels eingeschaltet.

Considerazioni sulla sicurezza



WARNING

Simbolo di riferimento alla documentazione. Se il prodotto è contrassegnato da questo simbolo, fare riferimento alla documentazione sul prodotto per ulteriori informazioni su di esso.

La dicitura **WARNING** denota un pericolo che può causare lesioni o morte.

Caution

La dicitura Caution denota un pericolo che può danneggiare le attrezzature.

Non procedere oltre un avviso di **WARNING** o di Caution prima di aver compreso le condizioni di rischio e aver provveduto alle misure del caso.

Questo prodotto è omologato nella classe di sicurezza I ed ha un terminale protettivo di collegamento a terra. Dev'essere installato un collegamento a terra di sicurezza, non interrompibile che vada dalla fonte d'alimentazione principale ai terminali d'entrata, al cavo d'alimentazione oppure al set cavo d'alimentazione fornito con il prodotto. Ogniquale volta vi sia probabilità di danneggiamento della protezione, disinserite il cavo d'alimentazione fino a quando il collegamento a terra non sia stato ripristinato.

Per la messa a terra dei cavi LAN:

- se la vostra LAN copre un'area servita da più di un sistema di distribuzione elettrica, accertatevi che i collegamenti a terra di sicurezza siano ben collegati fra loro;
- i cavi LAN possono occasionalmente andare soggetti a pericolose tensioni transitorie (ad esempio, provocate da lampi o disturbi nella griglia d'alimentazione della società elettrica); siate cauti nel toccare parti esposte in metallo della rete.

Nessun componente di questo prodotto può essere riparato dall'utente. Qualsiasi lavoro di riparazione, messa a punto, manutenzione o assistenza va effettuato esclusivamente da personale specializzato.

Questo apparato non possiede un commutatore principale; si mette sotto tensione all'inserirsi il cavo d'alimentazione.

Consideraciones sobre seguridad



Símbolo de referencia a la documentación. Si el producto va marcado con este símbolo, consultar la documentación del producto a fin de obtener mayor información sobre el producto.

WARNING

Una **WARNING** en la documentación señala un riesgo que podría resultar en lesiones o la muerte.

Caution

Una Caution en la documentación señala un riesgo que podría resultar en averías al equipo.

No proseguir después de un símbolo de **WARNING** o Caution hasta no haber entendido las condiciones peligrosas y haber tomado las medidas apropiadas.

Este aparato se enmarca dentro de la clase I de seguridad y se encuentra protegido por una borna de puesta a tierra. Es preciso que exista una puesta a tierra continua desde la toma de alimentación eléctrica hasta las bornas de los cables de entrada del aparato, el cable de alimentación o el juego de cable de alimentación suministrado. Si existe la probabilidad de que la protección a tierra haya sufrido desperfectos, desenchufar el cable de alimentación hasta haberse subsanado el problema.

Puesta a tierra del cable de la red local (LAN):

- Si la LAN abarca un área cuyo suministro eléctrico proviene de más de una red de distribución de electricidad, cerciorarse de que las puestas a tierra estén conectadas entre sí de modo seguro.
- Es posible que los cables de la LAN se vean sometidos de vez en cuando a voltajes momentáneos que entrañen peligro (rayos o alteraciones en la red de energía eléctrica). Manejar con precaución los componentes de metal de la LAN que estén al descubierto.

Este aparato no contiene pieza alguna susceptible de reparación por parte del usuario. Todas las reparaciones, ajustes o servicio de mantenimiento debe realizarlos solamente el técnico.

Este producto no tiene interruptor de potencia; se activa cuando se enchufa el cable de alimentación.

Safety Information (Japan)

安全性の考慮

安全記号



マニュアル参照記号。製品にこの記号がついている場合はマニュアルを参照し、注意事項等をご確認ください。

WARNING マニュアル中の「WARNING」は人身事故の原因となる危険を示します。

CAUTION マニュアル中の「CAUTION」は装置破損の原因となる危険を示します。

「WARNING」や「CAUTION」の項は飛ばさないで必ずお読みください。危険性に関する記載事項をよく読み、正しい手順に従った上で次の事項に進んでください。

これは安全性クラス I の製品で保護用接地端子を備えています。主電源から製品の入力配線端子、電源コード、または添付の電源コード・セットまでの間、切れ目のない安全接地が存在することが必要です。もしこの保護回路が損なわれたことが推測されるときは、接地が修復されるまで電源コードを外しておいてください。

LAN ケーブルの接地に関して:

- もし貴社の LAN が複数の配電システムにより電力を受けている領域をカバーしている場合には、それらのシステムの安全接地が確実に相互に結合されていることを確認してください。
- LAN ケーブルは時として危険な過度電圧（例えば雷や、配電設備の電力網での障害）にさらされることがあります。露出した金属部分の取扱いには十分な注意をはらってください。

本製品の内部にはユーザーが修理できる部品はありません。サービス、調整、保守および修理はサービス訓練を受けた専門家におまかせください。

本製品には電源スイッチがありません。電源コードを接続したとき電源入となります。

Japan Power Cord Warning

製品には、同梱された電源コードをお使い下さい。
同梱された電源コードは、他の製品では使用出来ません。

Safety Information (China)

HP 网络产品使用安全手册

使用须知

欢迎使用惠普网络产品，为了您及仪器的安全，请您务必注意如下事项：

1. 仪器要和地线相接，要使用有正确接地插头的电源线，使用中国国家规定的220V电源。
2. 避免高温和尘土多的地方，否则易引起仪器内部部件的损坏。
3. 避免接近高温，避免接近直接热源，如直射阳光、暖气等其它发热体。
4. 不要有异物或液体落入机内，以免部件短路。
5. 不要将磁体放置于仪器附近。

警告

为防止火灾或触电事故，请不要将该机放置于淋雨或潮湿处。

安装

安装辅助管理模块，请参看安装指南。

保修及技术支持

如果您按照以上步骤操作时遇到了困难，或想了解其它产品性能，请按以下方式与我们联系。

如是硬件故障：

1. 与售出单位或当地维修机构联系。
2. 中国惠普有限公司维修中心地址：
北京市海淀区知春路49号希格玛大厦
联系电话：010-62623888 转 6101
邮政编码：100080

如是软件问题：

1. 惠普用户响应中心热线电话：010-65645959
2. 传真自动回复系统：010-65645735

EMC Regulatory Statements

U.S.A.

FCC Class A

This equipment has been tested and found to comply with the limits for a Class A digital device, pursuant to Part 15 of the FCC Rules. These limits are designed to provide reasonable protection against interference when the equipment is operated in a commercial environment. This equipment generates, uses, and can radiate radio frequency energy and, if not installed and used in accordance with the instruction manual, may cause interference to radio communications. Operation of this equipment in a residential area may cause interference in which case the user will be required to correct the interference at his own expense.

Canada

This product complies with Class A Canadian EMC requirements.

Australia/New Zealand



This product complies with Australia/New Zealand EMC Class A requirements.

Japan

VCCI Class A

この装置は、情報処理装置等電波障害自主規制協議会（VCCI）の基準に基づくクラスA情報技術装置です。この装置を家庭環境で使用すると電波妨害を引き起こすことがあります。この場合には使用者が適切な対策を講ずるよう要求されることがあります。

Korea

사용자 안내문 : A 급기기

이기는 업무용으로 전자파 적합등록을 받은 기기 이오니, 판매자 또는 사용자는 이점을 주의하시기 바라며, 만약 잘못 구입하셨을 때에는 구입한 곳에서 비업무용으로 교환하시기 바랍니다.

Taiwan

警告使用者：這是甲類的資訊產品，在居住的環境中使用時，可能會造成射頻干擾，在這種情況下，使用者會被要求採取某些適當的對策。

Declaration of Conformity

Recycle Statements

Waste Electrical and Electronic Equipment (WEEE) Statements



Disposal of Waste Equipment by Users in Private Household in the European Union

This symbol on the product or on its packaging indicates that this product must not be disposed of with your other household waste. Instead, it is your responsibility to dispose of your waste equipment by handing it over to a designated collection point for the recycling of waste electrical and electronic equipment. The separate collection and recycling of your waste equipment at the time of disposal will help to conserve natural resources and ensure that it is recycled in a manner that protects human health and the environment. For more information about where you can drop off your waste equipment for recycling, please contact your local city office, your household waste disposal service or the shop where you purchased the product.



Likvidace zařízení soukromými domácími uživateli v Evropské unii

Tento symbol na produktu nebo balení označuje výrobek, který nesmí být vyhozen spolu s ostatním domácím odpadem. Povinností uživatele je předat takto označený odpad na předem určené sběrné místo pro recyklaci elektrických a elektronických zařízení. Okamžité třídění a recyklace odpadu pomůže uchovat přírodní prostředí a zajistí takový způsob recyklace, který ochrání zdraví a životní prostředí člověka. Další informace o možnostech odevzdání odpadu k recyklaci získáte na příslušném obecním nebo městském úřadě, od firmy zabývající se sběrem a svozem odpadu nebo v obchodě, kde jste produkt zakoupili.



Bortskaffelse af affald fra husstande i den Europæiske Union

Hvis produktet eller dets emballage er forsynet med dette symbol, angiver det, at produktet ikke må bortskaffes med andet almindeligt husholdningsaffald. I stedet er det dit ansvar at bortskaffe kasseret udstyr ved at aflevere det på den kommunale genbrugsstation, der forestår genvinding af kasseret elektrisk og elektronisk udstyr. Den centrale modtagelse og genvinding af kasseret udstyr i forbindelse med bortskaffelsen bidrager til bevarelse af naturlige ressourcer og sikrer, at udstyret genvindes på en måde, der beskytter både mennesker og miljø. Yderligere oplysninger om, hvor du kan aflevere kasseret udstyr til genvinding, kan du få hos kommunen, den lokale genbrugsstation eller i den butik, hvor du købte produktet.



Seadmete jäätmete kõrvaldamine eramajapidamistes Euroopa Liidus

See tootel või selle pakendil olev sümbol näitab, et kõnealust toodet ei tohi koos teiste majapidamisjäätmetega kõrvaldada. Teie kohus on oma seadmete jäätmed kõrvaldada, viies need elektri- ja elektroonikaseadmete jäätmete ringlussevõtmiseks selleks ettenähtud kogumispunkti. Seadmete jäätmete eraldi kogumine ja ringlussevõtmise ajala ootamine aitab kaitsta loodusvarasid ning tagada, et ringlussevõtmise toimub viisil, mis kaitseb inimtervist ning keskkonda. Lisateabe saamiseks selle kohta, kuhu oma seadmete jäätmed ringlussevõtmiseks viia, võtke palun ühendust oma kohaliku linnakantselei, majapidamisjäätmete kõrvaldamise teenistuse või kauplusega, kust Te toote ostsite.

Recycle Statements

Waste Electrical and Electronic Equipment (WEEE) Statements



Laitteiden hävittäminen kotitalouksissa Euroopan unionin alueella

Jos tuotteessa tai sen pakkauksessa on tämä merkki, tuotetta ei saa hävittää kotitalousjätteiden mukana. Tällöin hävitettävä laite on toimitettava sähkölaitteiden ja elektronisten laitteiden kierrätyspisteeseen. Hävitettävien laitteiden erillinen käsittely ja kierrätys auttavat säästämään luonnonvaroja ja varmistamaan, että laite kierrätetään tavalla, joka estää terveyshaitat ja suojelee luontoa. Lisätietoja paikoista, joihin hävitettävät laitteet voi toimittaa kierrätettäväksi, saa ottamalla yhteyttä jätehuoltoon tai liikkeeseen, josta tuote on ostettu.



Élimination des appareils mis au rebut par les ménages dans l'Union européenne

Le symbole apposé sur ce produit ou sur son emballage indique que ce produit ne doit pas être jeté avec les déchets ménagers ordinaires. Il est de votre responsabilité de mettre au rebut vos appareils en les déposant dans les centres de collecte publique désignés pour le recyclage des équipements électriques et électroniques. La collecte et le recyclage de vos appareils mis au rebut indépendamment du reste des déchets contribue à la préservation des ressources naturelles et garantit que ces appareils seront recyclés dans le respect de la santé humaine et de l'environnement. Pour obtenir plus d'informations sur les centres de collecte et de recyclage des appareils mis au rebut, veuillez contacter les autorités locales de votre région, les services de collecte des ordures ménagères ou le magasin dans lequel vous avez acheté ce produit.



Entsorgung von Altgeräten aus privaten Haushalten in der EU

Das Symbol auf dem Produkt oder seiner Verpackung weist darauf hin, dass das Produkt nicht über den normalen Hausmüll entsorgt werden darf. Benutzer sind verpflichtet, die Altgeräte an einer Rücknahmestelle für Elektro- und Elektronik-Altgeräte abzugeben. Die getrennte Sammlung und ordnungsgemäße Entsorgung Ihrer Altgeräte trägt zur Erhaltung der natürlichen Ressourcen bei und garantiert eine Wiederverwertung, die die Gesundheit des Menschen und die Umwelt schützt. Informationen dazu, wo Sie Rücknahmestellen für Ihre Altgeräte finden, erhalten Sie bei Ihrer Stadtverwaltung, den örtlichen Müllentsorgungsbetrieben oder im Geschäft, in dem Sie das Gerät erworben haben



Απορριψη άχρηστου εξοπλισμού από χρήστες σε ιδιωτικά νοικοκυριά στην Ευρωπαϊκή Ένωση

Το σύμβολο αυτό στο προϊόν ή τη συσκευασία του υποδεικνύει ότι το συγκεκριμένο προϊόν δεν πρέπει να διατίθεται μαζί με τα άλλα οικιακά σας απορρίμματα. Αντίθετα, είναι δική σας ευθύνη να ανακύκλωση άχρηστου ηλεκτρικού και ηλεκτρονικού εξοπλισμού. Η ξεχωριστή συλλογή και ανακύκλωση του άχρηστου εξοπλισμού σας κατά την απόρριψη θα συμβάλει στη διατήρηση των φυσικών πόρων και θα διασφαλίσει ότι η ανακύκλωση γίνεται με τρόπο που προστατεύει την ανθρώπινη υγεία και το περιβάλλον. Για περισσότερες πληροφορίες σχετικά με το πού μπορείτε να παραδώσετε τον άχρηστο εξοπλισμό σας για ανακύκλωση, επικοινωνήστε με το αρμόδιο τοπικό γραφείο, την τοπική υπηρεσία διάθεσης οικιακών απορριμμάτων ή το κατάστημα όπου αγοράσατε το προϊόν.



Készülékek magánháztartásban történő selejtezése az Európai Unió területén

A készüléken, illetve a készülék csomagolásán látható azonos szimbólum annak jelzésére szolgál, hogy a készülék a selejtezés során az egyéb háztartási hulladéktól eltérő módon kezelendő. A vásárló a hulladékká vált készüléket köteles a kijelölt gyűjtőhelyre szállítani az elektromos és elektronikai készülékek újrahasznosítása céljából. A hulladékká vált készülékek selejtezés kori begyűjtése és újrahasznosítása hozzájárul a természeti erőforrások megőrzéséhez, valamint biztosítja a selejtezett termékek környezetre és emberi egészségre nézve biztonságos feldolgozását. A begyűjtés pontos helyéről bővebb tájékoztatást a lakhelye szerint illetékes önkormányzattól, az illetékes személtakarító vállalattól, illetve a terméket elárúsító helyen kaphat.



Smaltimento delle apparecchiature da parte di privati nel territorio dell'Unione Europea

Questo simbolo presente sul prodotto o sulla confezione indica che il prodotto non può essere smaltito insieme ai rifiuti domestici. È responsabilità dell'utente smaltire le apparecchiature consegnandole presso un punto di raccolta designato al riciclo e allo smaltimento di apparecchiature elettriche ed elettroniche. La raccolta differenziata e il corretto riciclo delle apparecchiature da smaltire permette di proteggere la salute degli individui e l'ecosistema. Per ulteriori informazioni relative ai punti di raccolta delle apparecchiature, contattare l'ente locale per lo smaltimento dei rifiuti, oppure il negozio presso il quale è stato acquistato il prodotto.



Nolietotu iekārtu iznīcināšanas noteikumi lietotājiem Eiropas Savienības privātajās mājāsaimniecībās

Šāds simbols uz izstrādājuma vai uz tā iesaiņojuma norāda, ka šo izstrādājumu nedrīkst izmest kopā ar citiem sadzīves atkritumiem. Jūs atbildat par to, lai nolietotās iekārtas tiktu nodotas speciāli iekārtotos punktos, kas paredzēti izmantoto elektrisko un elektronisko iekārtu savākšanai otrreizējai pārstrādei. Atsevišķa nolietoto iekārtu savākšana un otrreizējā pārstrāde palīdzēs saglabāt dabas resursus un garantēs, ka šīs iekārtas tiks otrreizēji pārstrādātas tādā veidā, lai pasargātu vidi un cilvēku veselību. Lai uzzinātu, kur nolietotās iekārtas var izmest otrreizējai pārstrādei, jāvērsas savas dzīves vietas pašvaldībā, sadzīves atkritumu savākšanas dienestā vai veikalā, kurā izstrādājums tika nopirkts.



Vartotojū iš privačių namų ūkių įrangos atliekų šalinimas Europos Sąjungoje

Šis simbolis ant gaminio arba jo pakuotės rodo, kad šio gaminio šalinti kartu su kitomis namų ūkio atliekomis negalima. Šalintinas įrangos atliekas privalote pristatyti į specialią surinkimo vietą elektros ir elektroninės įrangos atliekoms perdirbti. Atskirai surenkamos ir perdirbamos šalintinos įrangos atliekos padės saugoti gamtinius išteklius ir užtikrinti, kad jos bus perdirbtos tokiu būdu, kuris nekenkia žmonių sveikatai ir aplinkai. Jeigu norite sužinoti daugiau apie tai, kur galima pristatyti perdirbtinas įrangos atliekas, kreipkitės į savo seniūniją, namų ūkio atliekų šalinimo tarnybą arba parduotuvę, kurioje įsigijote gaminį.



Verwijdering van afgedankte apparatuur door privé-gebruikers in de Europese Unie

Dit symbool op het product of de verpakking geeft aan dat dit product niet mag worden gedeponeerd bij het normale huishoudelijke afval. U bent zelf verantwoordelijk voor het inleveren van uw afgedankte apparatuur bij een inzamelingspunt voor het recyclen van oude elektrische en elektronische apparatuur. Door uw oude apparatuur apart aan te bieden en te recyclen, kunnen natuurlijke bronnen worden behouden en kan het materiaal worden hergebruikt op een manier waarmee de volksgezondheid en het milieu worden beschermd. Neem contact op met uw gemeente, het afvalinzamelingsbedrijf of de winkel waar u het product hebt gekocht voor meer informatie over inzamelingspunten waar u oude apparatuur kunt aanbieden voor recycling.



Pozbywanie się zużytego sprzętu przez użytkowników w prywatnych gospodarstwach domowych w Unii Europejskiej

Ten symbol na produkcie lub jego opakowaniu oznacza, że produktu nie wolno wyrzucać do zwykłych pojemników na śmieci. Obowiązkiem użytkownika jest przekazanie zużytego sprzętu do wyznaczonego punktu zbiórki w celu recyklingu odpadów powstałych ze sprzętu elektrycznego i elektronicznego. Osobna zbiórka oraz recykling zużytego sprzętu pomogą w ochronie zasobów naturalnych i zapewnią ponowne wprowadzenie go do obiegu w sposób chroniący zdrowie człowieka i środowisko. Aby uzyskać więcej informacji o tym, gdzie można przekazać zużyty sprzęt do recyklingu, należy się skontaktować z urzędem miasta, zakładem gospodarki odpadami lub sklepem, w którym zakupiono produkt.

**Descarte de Lixo Elétrico na Comunidade Européia**

Este símbolo encontrado no produto ou na embalagem indica que o produto não deve ser descartado no lixo doméstico comum. É responsabilidade do cliente descartar o material usado (lixo elétrico), encaminhando-o para um ponto de coleta para reciclagem. A coleta e a reciclagem seletivas desse tipo de lixo ajudarão a conservar as reservas naturais; sendo assim, a reciclagem será feita de uma forma segura, protegendo o ambiente e a saúde das pessoas. Para obter mais informações sobre locais que reciclam esse tipo de material, entre em contato com o escritório da HP em sua cidade, com o serviço de coleta de lixo ou com a loja em que o produto foi adquirido.

**Likvidácia vyradených zariadení v domácnostiach v Európskej únii**

Symbol na výrobku alebo jeho balení označuje, že daný výrobok sa nesmie likvidovať s domovým odpadom. Povinnosťou spotrebiteľa je odovzdať vyradené zariadenie v zbernom mieste, ktoré je určené na recykláciu vyradených elektrických a elektronických zariadení. Separovaný zber a recyklácia vyradených zariadení prispieva k ochrane prírodných zdrojov a zabezpečuje, že recyklácia sa vykonáva spôsobom chrániacim ľudské zdravie a životné prostredie. Informácie o zberných miestach na recykláciu vyradených zariadení vám poskytne miestne zastupiteľstvo, spoločnosť zabezpečujúca odvoz domového odpadu alebo obchod, v ktorom ste si výrobok zakúpili.

**Odstranjevanje odslužene opreme uporabnikov v zasebnih gospodinjstvih v Evropski uniji**

Ta znak na izdelku ali njegovi embalaži pomeni, da izdelka ne smete odvreči med gospodinjске odpadke. Nasprotno, odsluženo opremo morate predati na zbirališče, pooblaščeno za recikliranje odslužene električne in elektronske opreme. Ločeno zbiranje in recikliranje odslužene opreme prispeva k ohranjanju naravnih virov in zagotavlja recikliranje te opreme na zdravju in okolju neškodljiv način. Za podrobnejše informacije o tem, kam lahko odpeljete odsluženo opremo na recikliranje, se obrnite na pristojni organ, komunalno službo ali trgovino, kjer ste izdelek kupili.

**Eliminación de residuos de equipos eléctricos y electrónicos por parte de usuarios particulares en la Unión Europea**

Este símbolo en el producto o en su envase indica que no debe eliminarse junto con los desperdicios generales de la casa. Es responsabilidad del usuario eliminar los residuos de este tipo depositándolos en un "punto limpio" para el reciclado de residuos eléctricos y electrónicos. La recogida y el reciclado selectivos de los residuos de aparatos eléctricos en el momento de su eliminación contribuirá a conservar los recursos naturales y a garantizar el reciclado de estos residuos de forma que se proteja el medio ambiente y la salud. Para obtener más información sobre los puntos de recogida de residuos eléctricos y electrónicos para reciclado, póngase en contacto con su ayuntamiento, con el servicio de eliminación de residuos domésticos o con el establecimiento en el que adquirió el producto.

**Bortskaffande av avfallsprodukter från användare i privathushåll inom Europeiska Unionen**

Om den här symbolen visas på produkten eller förpackningen betyder det att produkten inte får slängas på samma ställe som hushållssopor. I stället är det ditt ansvar att bortskaffa avfallet genom att överlämna det till ett uppsamlingsställe avsett för återvinning av avfall från elektriska och elektroniska produkter. Separat insamling och återvinning av avfallet hjälper till att spara på våra naturresurser och gör att avfallet återvinns på ett sätt som skyddar människors hälsa och miljön. Kontakta ditt lokala kommunkontor, din närmsta återvinningsstation för hushållsavfall eller affären där du köpte produkten för att få mer information om var du kan lämna ditt avfall för återvinning.

Index

B

- back of unit ... 1-4
 - EPS ports ... 1-4
 - power connector ... 1-4
- basic troubleshooting tips ... 3-1

C

- cabinet
 - mounting the unit in ... 2-4
- cable length specifications ... A-2
- cables
 - connecting cables to the unit ports ... 2-9
 - length ... A-2
 - required types ... 2-4
 - requirements ... 2-4
 - testing ... 3-4
- cabling ... 2-4
- connecting the unit to a power source ... 2-10

D

- description ... 1-4
 - back of unit ... 1-4
 - LEDs ... 1-3
 - unit ... 1-1
- diagnostic tests ... 3-4
 - checking the LEDs ... 3-4
 - testing cabling ... 3-4
 - testing the unit only ... 3-4

E

- electrical specifications, unit ... A-1
- EMC regulatory statements ... B-8
- emissions specifications, unit ... A-2
- environmental specifications, unit ... A-1
- EPS ports
 - location on unit ... 1-4
 - operation description ... 1-4

F

- Fault LED ... 1-3
 - behaviors ... 1-3
 - blinking definition ... 1-3
 - showing error conditions ... 3-2
- flashing LEDs
 - error indications ... 3-2
- front of unit
 - LEDs ... 1-2

H

- horizontal surface
 - mounting unit on ... 2-7

I

- included parts ... 2-1
- installation
 - cable requirements ... 2-4
 - connecting the unit to a power source ... 2-10
 - horizontal surface mounting ... 2-7
 - location considerations ... 2-4
 - precautions ... 2-3
 - rack or cabinet mounting ... 2-4
 - site preparation ... 2-4
 - summary of steps ... 2-2

L

- LEDs
 - blinking definition ... 1-3
 - checking during troubleshooting ... 3-4
 - descriptions of ... 1-3
 - error indications ... 3-2
 - Fault ... 1-3
 - showing error conditions ... 3-2
 - location on unit ... 1-2
 - port description ... 1-3
 - Power ... 1-3
 - Power Supply Status ... 1-3
- location for the unit, considerations ... 2-4

M

- mounting the unit
 - in a rack or cabinet ... 2-4
 - on a horizontal surface ... 2-7

N

- network devices
 - connecting to the unit ... 2-9

P

- parts, included with the unit ... 2-1
- physical specifications, unit ... A-1
- port LEDs
 - description ... 1-3
- ports
 - connecting to ... 2-9
 - connections ... 2-9
 - location on unit ... 1-4
- power connector ... 1-4
- Power LED ... 1-3
 - behaviors ... 1-3
- power source
 - connecting the unit to ... 2-10
- Power Supply Status LED ... 1-3
- precautions
 - mounting the unit ... 2-3
 - power requirements ... 2-3
- preparing the installation site ... 2-4

R

- rack
 - mounting the unit in ... 2-4
- recycle statements ... C-1
- regulatory statements ... B-8
- resetting the unit
 - troubleshooting procedure ... 3-4
- RPS connections
 - sample topology ... 2-12

S

- safety and regulatory statements ... B-1

- safety specifications ... A-2
- specifications
 - cable length ... A-2
 - electrical ... A-1
 - emissions ... A-2
 - environmental ... A-1
 - physical ... A-1
 - safety ... A-2
- summary
 - of unit installation ... 2-2

T

- testing
 - cabling ... 3-4
 - checking the LEDs ... 3-4
 - diagnostic tests ... 3-4
 - unit operation ... 3-4
- tips for troubleshooting ... 3-1
- topologies
 - effects of improper topology ... 3-1
 - samples of ... 2-12
- troubleshooting ... 3-1
 - basic tips ... 3-1
 - checking the LEDs ... 3-4
 - common problems ... 3-1
 - diagnostic tests ... 3-4
 - effects of improper topology ... 3-1
 - testing the cables ... 3-4
 - testing the unit ... 3-4

U

- unit
 - connecting to a power source ... 2-10
 - electrical specifications ... A-1
 - emissions specifications ... A-2
 - environmental specifications ... A-1
 - included parts ... 2-1
 - mounting in a rack or cabinet ... 2-4
 - mounting on horizontal surface ... 2-7
 - physical specifications ... A-1
- unit operation
 - verifying after installation ... 2-11



Technical information in this document is subject to change without notice.

© Copyright 2007, Hewlett-Packard Development Company, L.P. Reproduction, adaptation, or translation without prior written permission is prohibited except as allowed under the copyright laws.

Printed in Singapore
February 2007

Manual Part Number
5991-4739

