

installation guide

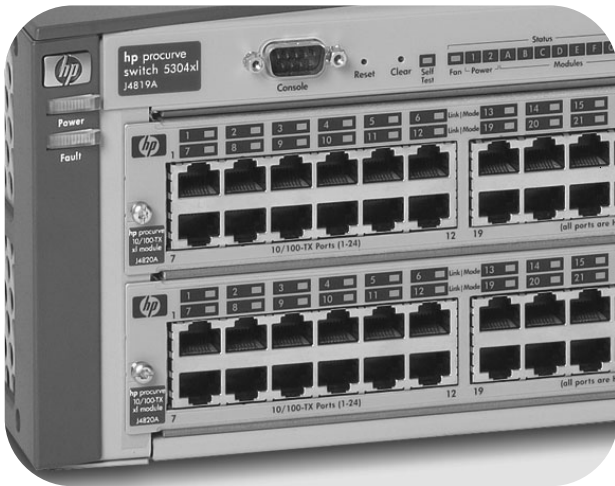

hp procurve switch
xl modules

www.hp.com/go/hpprocurve

HP ProCurve Switch xl Modules

Installation Guide

© Copyright 2001, 2005 Hewlett-Packard Development Company, L.P. The information contained herein is subject to change without notice.

This document contains proprietary information, which is protected by copyright. No part of this document may be photocopied, reproduced, or translated into another language without the prior written consent of Hewlett-Packard.

Publication Number

5991-2130
March 2005

Applicable Products

HP ProCurve Switch 10/100-TX x1 Module (J4820A)
HP ProCurve Switch 100/1000-T x1 Module (J4821A)
HP ProCurve Switch 100-FX MTRJ x1 Module (J4852A)
HP ProCurve Switch mini-GBIC x1 Module (J4878A)
HP ProCurve switch x1 PoE Module (J8161A)
HP ProCurve Switch 10/100/1000-T x1 Module (J4907A)
HP ProCurve 600 Redundant and External Power Supply (J8168A)
HP ProCurve 610 External Power Supply (J8169A)
HP ProCurve Switch Access Controller x1 Module (J8162A)

Disclaimer

HEWLETT-PACKARD COMPANY MAKES NO WARRANTY OF ANY KIND WITH REGARD TO THIS MATERIAL, INCLUDING, BUT NOT LIMITED TO, THE IMPLIED WARRANTIES OF MERCHANTABILITY AND FITNESS FOR A PARTICULAR PURPOSE. Hewlett-Packard shall not be liable for errors contained herein or for incidental or consequential damages in connection with the furnishing, performance, or use of this material.

The only warranties for HP products and services are set forth in the express warranty statements accompanying such products and services. Nothing herein should be construed as constituting an additional warranty. HP shall not be liable for technical or editorial errors or omissions contained herein.

Hewlett-Packard assumes no responsibility for the use or reliability of its software on equipment that is not furnished by Hewlett-Packard.

Warranty

See the Customer Support/Warranty booklet included with the product.

A copy of the specific warranty terms applicable to your Hewlett-Packard product and replacement parts can be obtained from your HP sales and service office or HP-authorized reseller.

Contents

Descriptions	1
Features	3
Features and functionality of the ProCurve Switch Access Controller xl Module (J8162A).	4
The ProCurve Switch xl Modules have the following features:	6
Installing the Modules	7
Overview	7
Installing the Module in an Unused Slot	8
Installation Precautions:	8
Installation Procedures:	8
Installing or Removing the mini-GBICs	10
Connecting an HP ProCurve External Power Supply	11
Connecting the EPS connector	11
Connecting or disconnecting RJ-45 connectors	12
HP ProCurve Switch PoE xl Module Configurations	13
PoE Power Requirements	14
PoE Module LEDs	14
Port LEDs	14
Status LEDs	15
LED Mode LEDs	15
Verifying the Module is Installed Correctly	16
Connecting the Network Cables	17
Verifying the Network Connections Are Working	20
Customizing the Port Configuration	21
Replacing or Removing a Module	23
Resetting the Switch	24
Reasons for Resetting the Switch	24
Methods of Resetting the Switch	24
Troubleshooting	25
PoE LED Behavior	25
LED Error Indicators:	26
Diagnostic Tips:	26

Customer Support Services	30
Specifications	30
Environmental	30
Lasers	30
Connectors	31
Twisted-Pair	31
Fiber-Optic	31
Cables	32
Twisted-Pair Cables	32
Fiber-Optic Cables	33
Mode Conditioning Patch Cord for Gigabit-LX	34
Installing the Patch Cord	35
Recommended Patch Cords	35
EMC Regulatory Statements	36
U.S.A.	36
Canada	36
Australia/New Zealand	36
Japan	36
Korea	37
Taiwan	37
European Community Declaration of Conformity	37

HP ProCurve Switch xl Modules

For the HP ProCurve Series 5300xl Switches

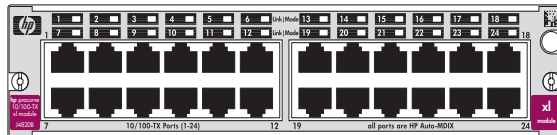
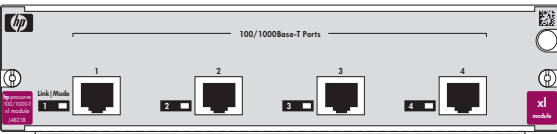
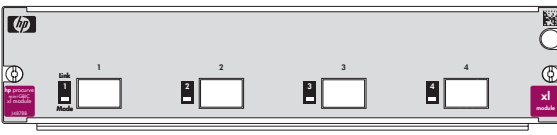
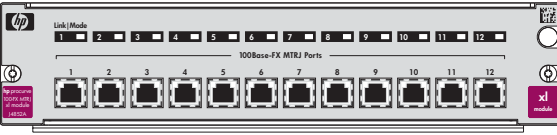

Descriptions. The HP ProCurve Switch xl Modules are components that you can add to an HP ProCurve xl switch to provide a variety of network connectivity options. The following modules are available as of this printing:

Module	Module	Description
HP ProCurve Switch 10/100-TX xl Module (J4820A)		24 twisted-pair ports with RJ-45 connectors for 10 Mbps or 100 Mbps operation over 100-ohm unshielded (UTP) or shielded (STP) twisted-pair cable – all ports have the HP Auto-MDIX feature.
HP ProCurve Switch 100/1000-T xl Module (J4821A)		4 twisted-pair ports with RJ-45 connectors for 1000 Mbps (Gigabit) or 100 Mbps operation over Category 5 or better 100-ohm UTP or STP cable (<i>category 5e recommended for Gigabit</i>) – all ports have the IEEE 802.3ab Auto MDI/MDI-X feature.
HP ProCurve Switch mini-GBIC xl Module (J4878A)		4 slots for installing any of the supported HP ProCurve mini-GBICs*.
HP ProCurve Switch 100-FX MTRJ xl Module (J4852A) ¹		12 100-FX ports with MT-RJ connectors for 100 Mbps networking over multimode fiber-optic cable.

* **Supported mini-GBICs:** The following HP ProCurve mini-GBICs are supported by the mini-GBIC xl Module (as of this printing): • Gigabit-SX LC mini-GBIC (J4858A) • Gigabit-LX LC mini-GBIC (J4859A) • Gigabit-LH LC mini-GBIC (J4860A) • Gigabit 1000Base-T mini-GBIC (J8177B)

HP ProCurve Switch xl Modules

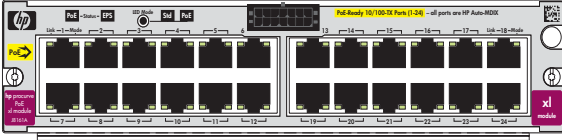
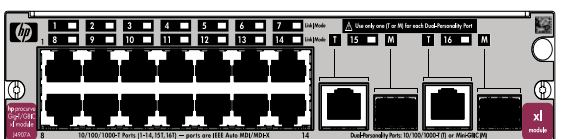
Descriptions

Module	Image	Description
HP ProCurve Switch PoE xl Module (J8161A) ²		24 10/100-TX ports and when connected to an HP ProCurve 600 Redundant and External Power Supply (J8168A), can provide Power over Ethernet (PoE) power to 802.3af compliant devices.
HP ProCurve Switch 10/100/1000-T xl Module (J4907A) ³ <p>The following HP ProCurve mini-GBICs are supported by the 10/100/1000-T xl Module (as of this printing):</p> <ul style="list-style-type: none"> • Gigabit-SX LC mini-GBIC (J4858A) • Gigabit-LX LC mini-GBIC (J4859A) • Gigabit-LH LC mini-GBIC (J4860A) • The Gigabit 1000Base-T mini-GBIC (J8177B) is not supported on the 10/100/1000-T xl Module (J4907A). 		14 twisted-pair ports with RJ-45 connectors for 10/100/1000 Mbps (Gigabit) or 100 Mbps operation over Category 5 or better 100-ohm UTP or STP cable (<i>category 5e recommended for Gigabit</i>) – all ports have the IEEE 802.3ab Auto MDI/MDI-X feature, and 2 slots for installing any supported ProCurve mini-GBICs.
HP ProCurve Switch Access Controller xl Module (J8162A) ⁴ <p>Note</p> <p>Due to power consumption, no more than two J8162As are supported in the chassis at a time.</p> <p>WARNING</p> <p>This product contains a Lithium coin-type battery (type CR2032) that requires special handling at end-of-life. The battery can explode or cause burns if disassembled, charged, or exposed to water, fire or high temperature. After replacing the battery, properly dispose of used battery.</p>		There are no ports on the J8162A. It operates as a wireless access controller. Wireless traffic is directed to this module using VLAN's. For configuration information see your <i>HP ProCurve Series 5300xl Switches Installation and Getting Started Guide</i> , Chapter 3, "Getting Started with Switch Configuration".
<p>¹ This module requires switch software version E.07.01 or later to be installed in the switch.</p> <p>² This module requires switch software version E.08.20 or later to be installed in the switch.</p> <p>³ This module requires switch software version E.08.42 or later to be installed in the switch.</p> <p>⁴ This module requires switch software version E.09.2x or later to be installed in the switch.</p>		
Contact your HP-authorized networking products reseller or your HP representative for information on availability of other modules and mini-GBICs. You can also visit the HP networking products web site http://www.hp.com/go/procurve to get more information.		

Features

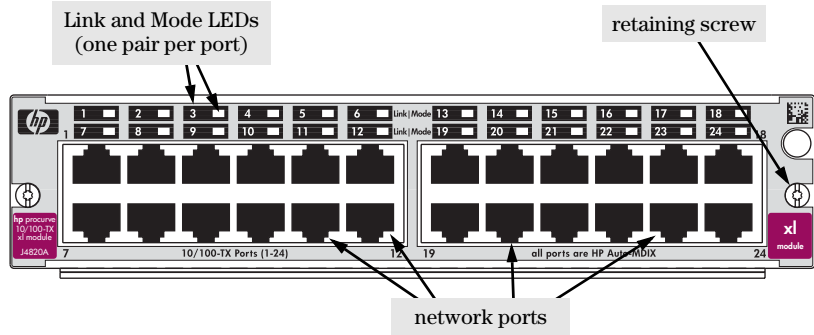

Example: HP ProCurve 24-Port 10/100-TX xl Module

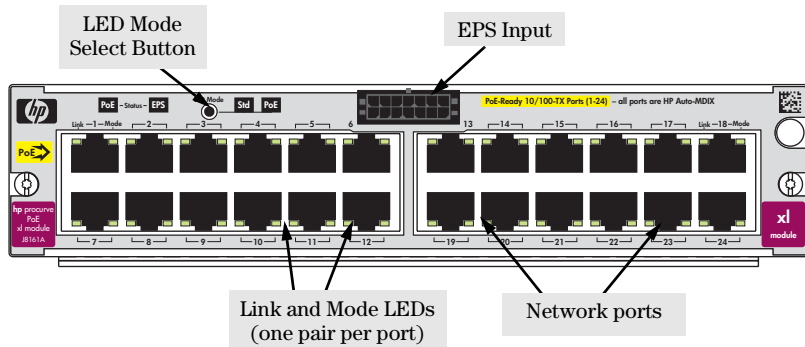

Example: HP ProCurve Switch PoE xl Mod-

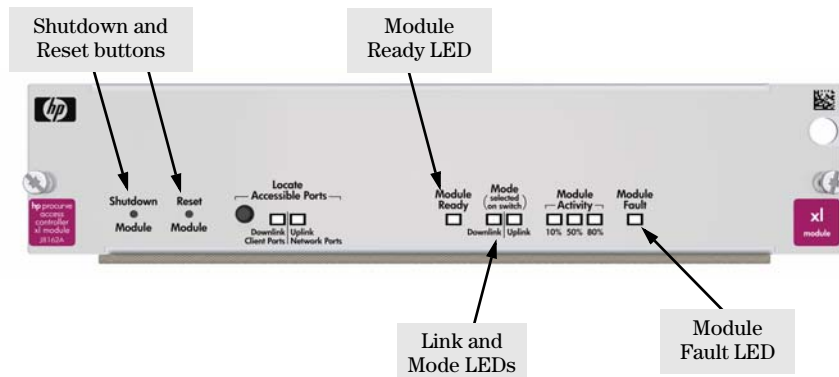

Example: HP ProCurve Switch Access Controller xl Module

Features and functionality of the ProCurve Switch Access Controller xl Module (J8162A).

- Shutdown Module—This is a recessed push button switch that when pressed and held for more than 2 seconds, initiates an orderly shutdown. During the shutdown process the Module Ready LED blinks. When the shutdown is complete enough for a safe module removal, the Module Ready LED turns off. It is highly recommended to shutdown the module before resetting or removing the module.
- Reset Module—This is a recessed push button switch. When this switch is pressed it causes an immediate reset of the module's hardware. Pressing this switch after the shutdown completes will initiate an orderly restart of the module. It is highly recommended to *not* press this switch before a shutdown completes. This could cause unpredictable activity by the module.
- Locate Accessible Ports—This button is used to display the associated downlink and uplink ports. The first press of the button lights the Downlink Client Ports LED on the module and also lights all associated Downlink Client Port LEDs on the other modules in the switch chassis. Downlink ports connect to devices such as wireless access points. If the button is not pressed again within a few seconds the LEDs turn off and the button is reset to the first position. Upon initial installation there are no Downlink Client Ports. For more information, see the *Management and Configuration Guide* on the Documentation CD-ROM that came with your switch or for the latest version you can also visit the HP networking products web site <http://www.hp.com/go/procurve>.

The second press of the button lights the Uplink Network Ports LED on the module and also lights all associated Uplink Port LEDs on the other associated modules in the switch chassis. Uplink ports are those typically used for connecting to the fabric. The ProCurve Switch Access Controller xl Module will communicate with the ProCurve Access Control Server 740wl (J8154A) or the ProCurve Integrated Access Manager 760wl (J8155A) through one of these ports.

If the button is not pressed again within a few seconds the LEDs will turn off and the button is reset to the first position.

A third press of the button turns all accessible port LEDs off and resets the button to the first position.

- Downlink Client Ports—This LED is associated with the Locate Accessible Ports button and comes on when the button is pressed once.
- Uplink Network Ports—This LED is associated with the Locate Accessible Ports button and comes on when the button is pressed for the second time.

- **Module Ready LED**—This LED comes on after the module completes the boot up and self test processes and indicates the module is up and running.
- **Mode (selected on switch)**—These LEDs operate in conjunction with the Mode Select button on the switch chassis to show port activity, duplex mode and link speed. For example, if you have selected “Act” with the Mode Select button on the chassis, then the two Mode LEDs on the module (Downlink and Uplink) will blink if there is activity on those ports. For more information refer to LEDs on Page 1-6 of the *HP ProCurve Series 5300xl Switches Installation and Getting Started Guide*.
- **Module Activity (10%, 50%, 80%)**—These LEDs come on according to the amount of activity or load the module is experiencing. For example, 10% indicates that the module has a light load, however, 80% indicates that the module is nearing work load saturation.
- **Module Fault**—This LED (colored orange) comes on when there is an error condition detected in the module.

Battery Installation Required

The Access Controller xl Module (J8162A) ships without the clock battery installed. You must insert the battery before installing the module into the switch. See the following graphic for instructions.

Insert the battery with the lettering and the plus “+” sign facing up.

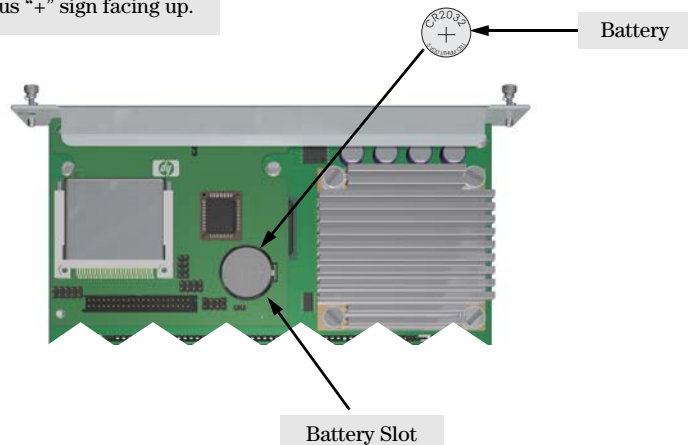

The ProCurve Switch xl Modules have the following features:

- auto-enabled ports—the ports are all configured to be ready for network operation as soon as a viable network cable is connected
 - auto-configuration—a default configuration is applied to the module when the switch is powered on and the module passes self test; this default configuration works well for most network installations
 - LEDs that provide information for each port on the link status, network activity, connection bandwidth (speed), communication mode (half or full duplex), and presence of specific network error packets on the port
 - “hot swap modules” operation—you can add a module or replace a module without having to shut down the switch (changing the module type in a given slot *does* require a switch reset)
 - “hot swap mini-GBICs” operation—you can add, replace, or change the type of any of the mini-GBICs that you use in the mini-GBIC xl Module, without having to first remove the module, and without having to shut down the switch
 - the ports on the 10/100-TX and PoE Modules have the **HP Auto-MDIX** feature, and the ports on the 100/1000-T xl Module have the IEEE 802.3ab **Auto MDI/MDI-X** feature. These features operate the same way and allow you to use either straight-through or crossover twisted-pair cables for all the twisted-pair network connections. Please see the note on “Automatic Cable Sensing” on [page 20](#).
 - the ports on the PoE xl Module have the same functionality as the 10/100-TX xl Module and also include PoE functionality when connected to an HP ProCurve 600 Redundant and External Power Supply (J8168A).
 - standards adherence:
 - the 10/100-TX xl Module is compatible with the IEEE 802.3 10Base-T and IEEE 802.3u 100Base-TX standards
 - the 100/1000-T xl Module is compatible with the IEEE 802.3ab 1000Base-T and IEEE 802.3u 100Base-TX standards
 - the ports on the SX and LX mini-GBICs that are installed in the mini-GBIC xl Module are compatible with the IEEE 802.3z Gigabit-SX and Gigabit-LX standards respectively.
 - the ports on the 100-FX MTRJ xl Module are compatible with the IEEE 802.3u 100-FX standard.
 - the PoE xl Module is compatible with the IEEE 802.3 10Base-T, 802.3u 100Base-TX, and the 802.3af Power over Ethernet standards.
 - the 16 port 10/100/1000Base-T xl Module is compatible with 802.3 (10Base-T), 802.3u (100Base-TX), and 802.3ab (1000Base-T) IEEE standards.
-

Installing the Modules

Overview

Before installing any module, ensure you have loaded the most current software for that module onto your switch, see [page 2](#) for module software codes. You can install any of the modules into any of the HP ProCurve xl Switches that have a compatible module slot. As of this printing, those are the HP ProCurve Series 5300xl Switches:

- 5308xl (p/n J4819A)
- 5372xl (p/n J4848B)
- 5348xl (p/n J4849B)
- 5304xl (p/n J4850A)

“Hot Swap” Notes

The mini-GBICs can be “hot swapped”. That is, they can be installed or removed after the mini-GBIC xl Module is installed in the switch and the module is receiving power, see [page 10](#).

You can “hot-swap” one module for another; that is, replace one module with another while the switch is still powered on, without interrupting the operation of the rest of the switch ports, see [page 24](#). You may have to reconfigure the switch if the modules are not the same type, check your configuration.

You can install the modules into the switch either with the switch powered on or off. The following procedures assume the switch is powered on.

1. Install the modules in a switch slot ([page 8](#)).
If you have installed any modules into slots that were previously occupied by a different type module, you need to reset the switch ([page 25](#)).
 2. If you are using the mini-GBIC xl Module, install the mini-GBICs in the module. You can install the mini-GBICs before or after installing that module into the switch ([page 10](#)).
 3. Optionally, connect an HP ProCurve 600 Redundant and External Power Supply to the xl PoE EPS input, using the supplied EPS cable ([page 11](#)).
 4. Verify the modules are installed correctly ([page 17](#)).
 5. Connect the network cabling ([page 18](#)).
 6. Verify the network connections are working properly ([page 21](#)).
 7. Optionally, customize the configuration for the modules’ ports (unless the default port configuration is satisfactory for your network application ([page 22](#))).
-

Installing the Module in an Unused Slot

Installation Precautions:

- Static electricity can severely damage the electronic components on the modules. When handling and installing the modules in your switch, follow these procedures to avoid damage from static electricity:
 - Handle the module by its bulkhead or edges and avoid touching the components and the circuitry on the board.
 - When installing the module, equalize any static charge difference between your body and the switch by wearing a grounding wrist strap and attaching it to the switch's metal body, or by frequently touching the switch's metal body.
- ***The HP ProCurve Switch xl Modules have “low-force”, high-performance connectors. High insertion forces are not necessary to install the modules, and should not be used.***
- ***Ensure you fully insert the modules.*** That is, press the module into the slot until the bulkhead on the module is contacting or is very close to contacting the front face of the switch chassis.
- Once the module is fully inserted, make sure you screw in the two retaining screws to secure the module in place.
- For safe operation, proper switch cooling, and reduction of electromagnetic emissions, ensure that a slot cover is installed on any unused module slot. *For safety, no more than one slot should be uncovered at a time when the switch is powered on.*

Installation Procedures:

1. Use a Torx T-10 or flat-bladed screwdriver to unscrew the screws in the cover plate over the slot you want to use, and remove the cover. Store the cover plate for possible future use.
2. Hold the module by its bulkhead—taking care not to touch the metal connectors or components on the board.
3. As shown in the following illustrations, insert the module into the slot guides and slide it into the slot until it stops. Then press near the two screws on the module bulkhead to seat the module connector into the switch backplane. The module bulkhead should be in contact with or very close to contact with the back face of the switch.

HP ProCurve Switch xl Modules Installing the Modules

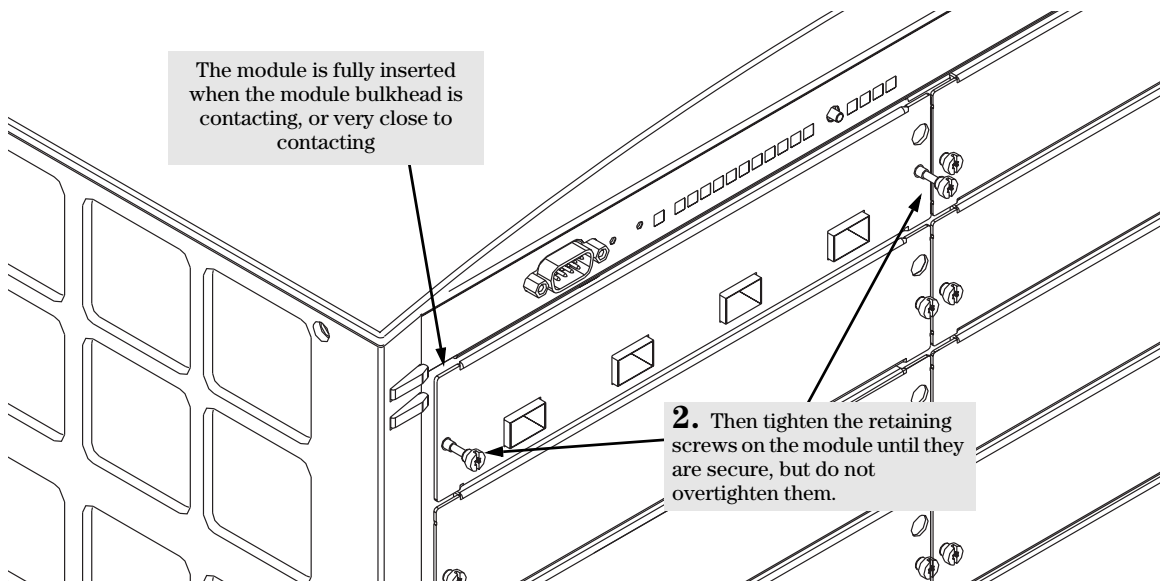
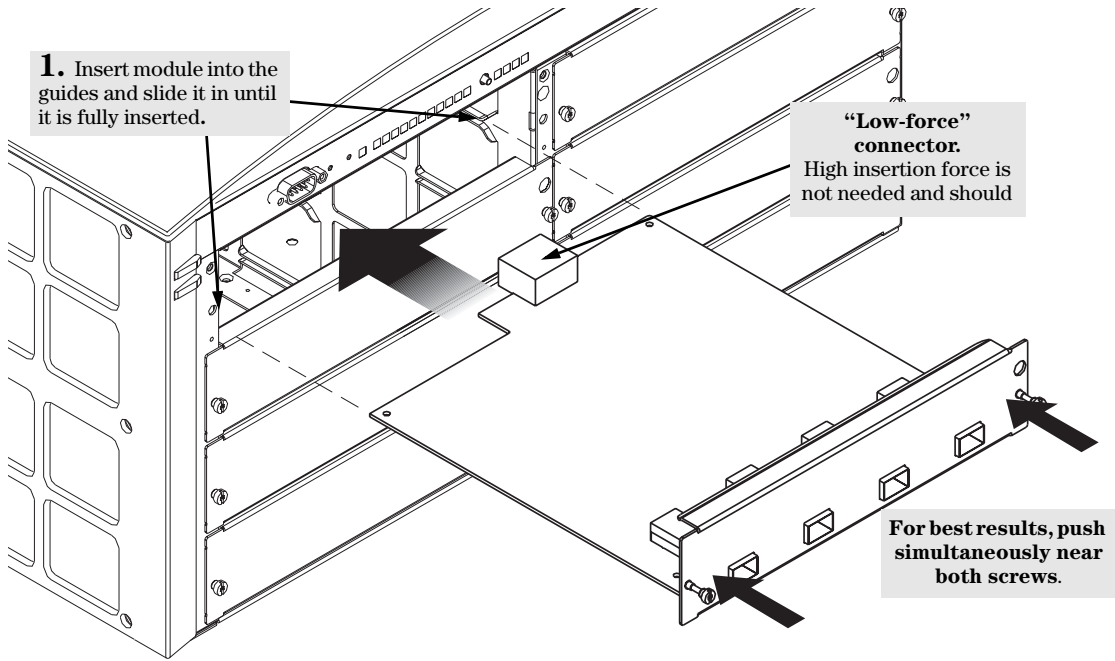

Installing or Removing the mini-GBICs

You can install or remove a mini-GBIC from the mini-GBIC xl Module without having to power off the switch. Use only HP ProCurve mini-GBICs.

WARNING

The HP ProCurve mini-GBICs are Class 1 laser devices. Avoid direct eye exposure to the beam coming from the transmit port.

Installing the mini-GBICs:

Hold the mini-GBIC by its sides and gently insert it into any of the slots in the module until the mini-GBIC clicks into place.

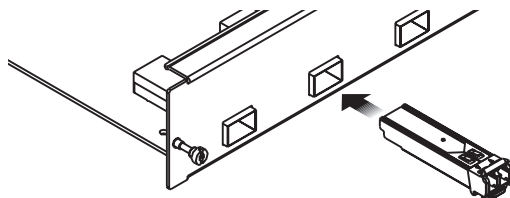

Removing the mini-GBICs:

You should disconnect the network cable from the mini-GBIC before removing it from the module.

Depending on when you purchased your HP ProCurve mini-GBICs, it may have either of three different release mechanisms: a plastic tab on the bottom of the mini-GBIC, a wire bail, or a plastic collar around the mini-GBIC.

To remove the mini-GBICs that have the plastic tab or plastic collar, push in the plastic tab or collar toward the switch until you see the mini-GBIC release from the switch (you can see it move outward slightly), and then pull it from the slot.

To remove the mini-GBICs that have the wire bail, lower the bail until it is approximately horizontal, and then using the bail, pull the mini-GBIC from the slot.

Connecting an HP ProCurve External Power Supply

Power over Ethernet technology allows IP telephones, wireless LAN Access Points and other appliances to receive power as well as data over existing LAN cabling, without needing to modify the existing Ethernet infrastructure. For more information on PoE, refer to the *HP ProCurve PoE Planning and Implementation Guide*.

The HP ProCurve Switch PoE xl Module (J8161A) is a module for the HP ProCurve 5300xl Switch and has 24 auto-sensing 10/100-TX RJ-45 ports. All 24 ports are capable of supplying PoE power. However, for the module itself to be able to supply PoE power it first must be connected to an external power supply (EPS) port on an HP ProCurve 600 Redundant and External Power Supply (J8168A) or an HP ProCurve 610 External Power Supply (J8169A), hereafter referred to as the External Power Supply (EPS).

Connecting the EPS connector

1. If installed, remove the RJ-45 connectors from ports 6 and 13.
2. Connect the EPS cable. Push the connector in firmly until fully seated.
3. Install the cable retention bracket (CRB).

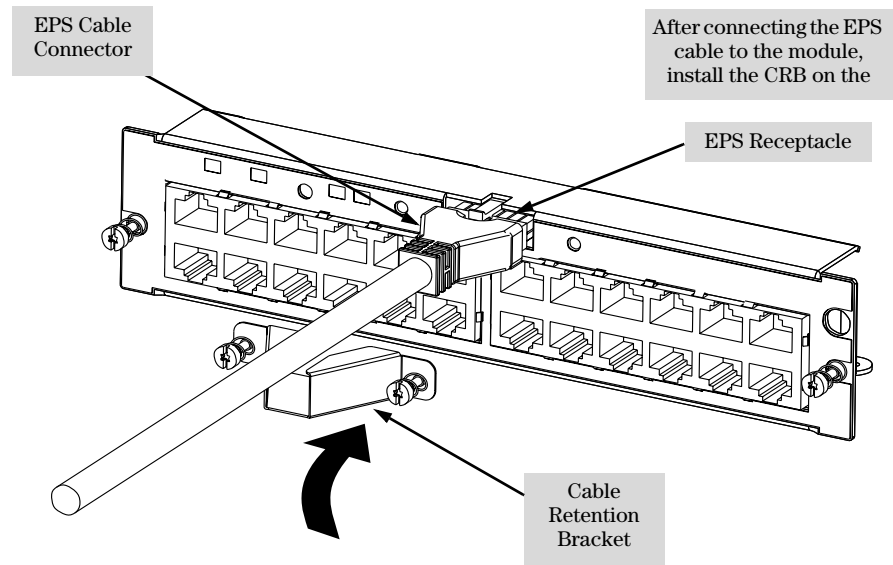

4. Secure the CRB to the module bulkhead.

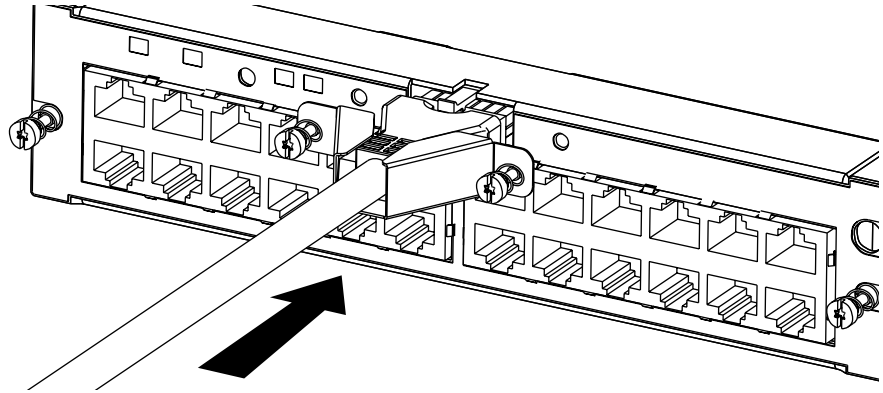

5. Install (or re-install) the RJ45 connectors in ports 6 and 13.

The opposite procedure is used when disconnecting the EPS cable connector.

Connecting or disconnecting RJ-45 connectors

To insert or remove an RJ-45 connector in port 6 or 13, depress the RJ-45 connector clip in order to clear the EPS cable retention bracket.

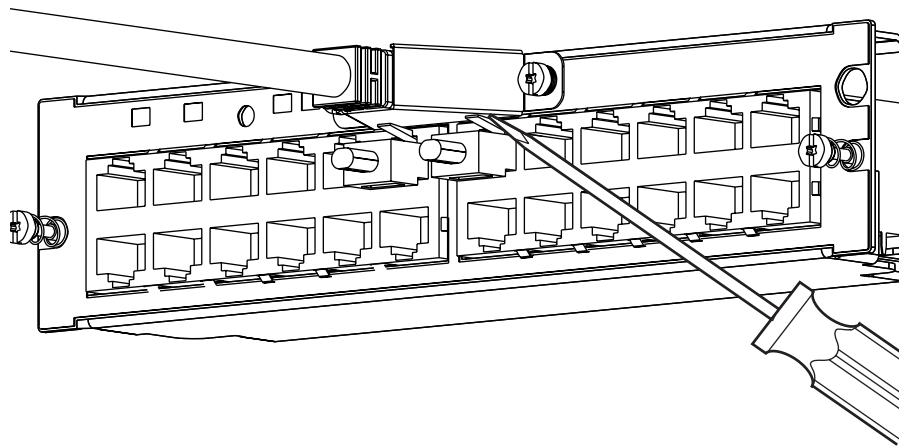

HP ProCurve Switch PoE xl Module Configurations

For the HP ProCurve Switch PoE xl Module to function it must be installed in any slot of an HP ProCurve Switch 5300xl. The module will receive its operational power from the switch and its PoE power from the HP 600 RPS/EPS or the HP 610 EPS.

The following examples show some possible configurations. The PoE power available to a PoE xl module depends on how many devices are connected to the EPS ports of the HP 600 RPS/EPS or the HP 610 EPS. In Configuration A, there are 408 watts available for the one module to distribute to attached devices; in Configuration B, there are 204 watts available to each module to distribute; in Configuration C, there are 408 watts available to each module; and in Configuration D, there are 204 watts available to each module. (See PoE Power Requirements [page 14](#)). For more information, refer to the *HP ProCurve PoE Planning and Implementation Guide*.

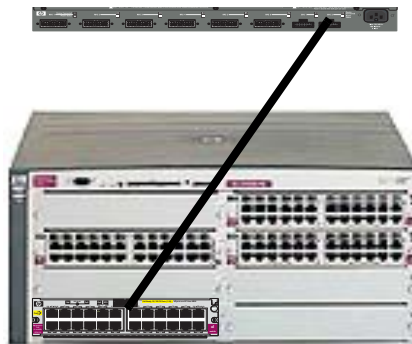

Configuration A: EPS Powering a Single module

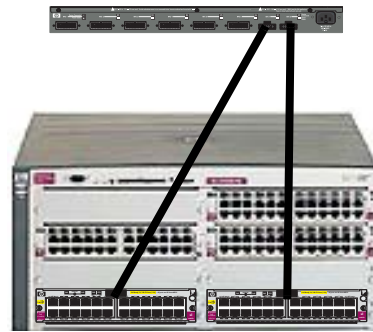

Configuration B: EPS Powering two modules

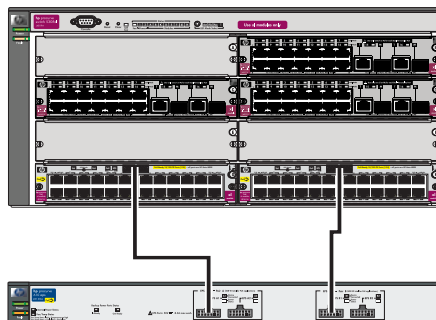

Configuration C: EPS Powering two modules

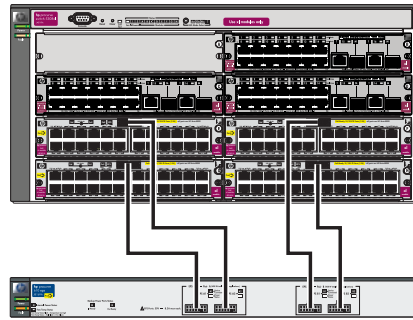

Configuration D: EPS Powering four modules

PoE Power Requirements

HP 600 RPS/EPS

# of Modules being Powered	Watts Available	# of Ports Powered and Average Watts/Port
One Module	408	24 @ average 15.4 W each
Two Modules	204/each module	24 @ average 7.6 W each

HP 610 EPS

# of Modules being Powered	Watts Available	# of Ports Powered and Average Watts/Port
Two Module	408	24 @ average 15.4 W each
Four Modules	204/each module	24 @ average 7.6 W each

When a powered device (PD) is initially connected to a PoE port, a minimum of 15.4 watts of available power is required to begin the power-up sequence. This 15.4 watts is needed to determine the type of PD requesting power. Once the power classification is determined and power is supplied, any power beyond the maximum power requirements for that class of PD is available for use by other ports.

In the default switch configuration all PoE ports have a Low priority. If the switch has less than 15.4 W of PoE power available, the switch transfers power from lower-priority ports to higher-priority ports. Within each priority class, a lower numbered port is supplied power before a higher numbered port. For more information refer to “Power over Ethernet (PoE) Operation” in the *Management and Configuration Guide*

Disconnecting a PD from a port causes the switch to stop providing power to that port and makes that power available to other ports configured for PoE operation. For more information on PoE power requirements refer to the *HP ProCurve PoE Planning and Implementation Guide* that came with your HP 600 RPS/EPS or HP 610 EPS.

PoE Module LEDs

Port LEDs

There are two LEDs for each port:

- The Link LED lights with a valid 10base-T or 100base-TX connection.
- The Mode LED lights according to the LED mode selected on the chassis and the LED mode selected on the HP ProCurve Switch PoE xl module. If the module's LED mode selection is Std (standard), then the Mode LED behaves as other HP ProCurve switch modules:

Chassis Mode Switch Setting	Description	Port Indication - LED On
Act	Activity	Transmit or Receive Traffic Present
FDx	Full Duplex	Full Duplex Mode of Operation
Max	Maximum Speed	Operation in 100Mbps
!	Attention	Experiencing any of a fixed set of errors

If the module's LED mode is PoE, the Mode LED provides information on the status of the PoE connection for that port:

- If the Mode LED in on the port is providing PoE power.
- If the Mode LED is off the port is not providing PoE power.

Status LEDs

There are two status LEDs:

- PoE - lights when PoE power is being supplied to one or more PDs. It goes out when there are no valid loads attached to any of the ports. It will blink to indicate an error on any of the ports or when any port is denied PoE power.
- EPS - lights when the module is connected to an HP 600 RPS/EPS or an HP 610 EPS. It goes out when the HP 600 RPS/EPS or HP 610 EPS is disconnected from the module. It blinks when there is an error on the HP 600 RPS/EPS or HP 610 EPS or it is over-subscribed, more PoE power is needed than the HP 600 RPS/EPS or HP 610 EPS can supply.

LED Mode LEDs

The Std or PoE LED lights depending on which mode has been selected by pressing the LED Mode button.

If the Std LED lights, the Link and Mode Port LEDs display information as listed in the previous table.

If the PoE Mode LED lights:

- The Link LED is on, indicating there is a valid 10base-T or 100base-TX connection.
- The Mode LED is on, indicating that the port is providing PoE power.
- The Mode LED is off, indication that the port is not providing PoE power.

Verifying the Module is Installed Correctly

Observe the Module Status LED for the slot in which the module is being installed, and the Self Test and Fault LEDs on the switch to verify the module is installed properly.

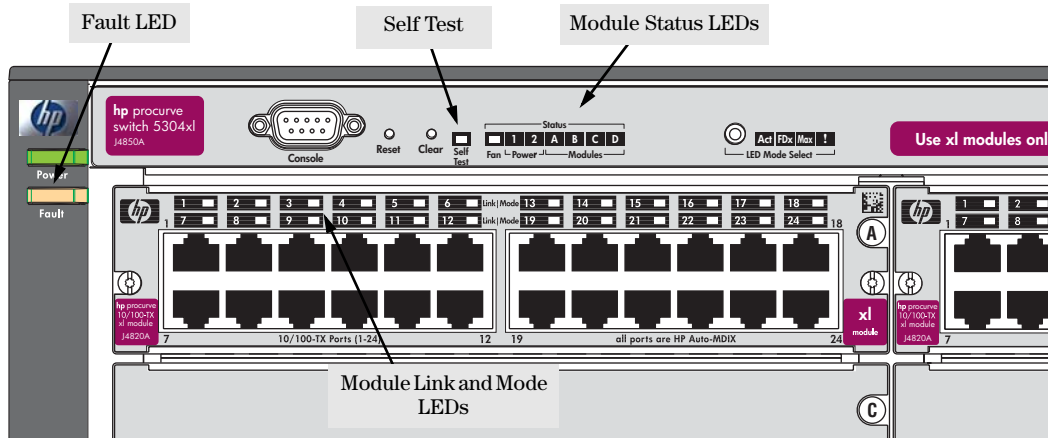

When the module is installed properly and the switch is powered on, or the module is installed when the switch already has power, the module undergoes a self test that takes a few seconds. You can use the LEDs to determine that the module is installed properly and has passed the self test, as described in the “LED Behavior” table below.

LED Behavior

LED	Display for a Properly Installed Module
Module Status	(for the slot in which you are installing the module) The LED goes ON as soon as the module is installed and the switch is powered on, and stays ON steadily.
Self Test	ON briefly while the module is being tested, then OFF. Note: If the switch was powered off while the module was installed, when the switch is powered on, the Self Test LED will stay ON for the duration of the whole switch self test.
Fault	OFF
Link and Mode (on the modules)	For a module that is installed when the switch is already powered on (hotswap), all the Link and Mode LEDs on the module go ON for approximately 3 to 10 seconds, then OFF for 5 to 10 seconds depending on the module. Then, the Self Test LED on the switch goes OFF. If the module is already installed when the switch is powered on or reset, the process described above occurs approximately 30 seconds after the power on or reset, during which the switch is being tested.

Connecting the Network Cables

Connect the appropriate network cables to the module's ports as shown in the table below. For more information on the cable specifications, see “Cables” on [page 33](#).

Supported Cable Types

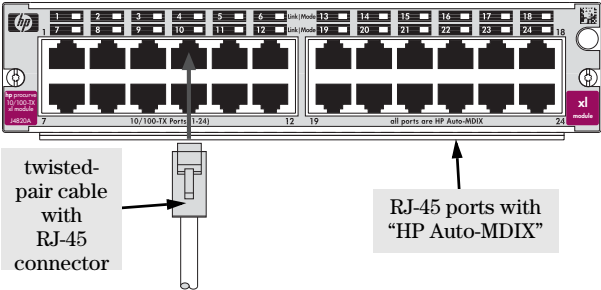
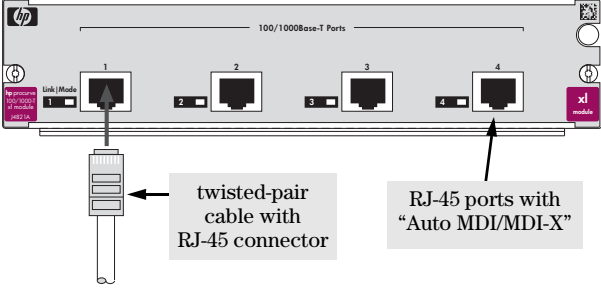
Module	Cable Type	Maximum Length
<p>10/100-TX and PoE xl Modules</p> 	<p>10 Mbps operation: category 3, 4, or 5, 100-ohm balanced twisted-pair cable</p> <p>100 Mbps operation: category 5, 100-ohm balanced twisted-pair cable</p>	<p>100 meters (recommended)</p> <p>100 meters</p>
<p>100/1000-T xl Module</p> 	<p>100 Mbps operation: category 5, 100-ohm balanced twisted-pair cable</p> <p>1000 Mbps (Gigabit) operation: category 5e, 100-ohm cable is recommended, although category 5 cable may also work.</p>	<p>100 meters</p> <p>100 meters</p>

Notes:

- The RJ-45 ports on this module have the HP Auto-MDIX feature. In the module's default configuration, Auto, **either a straight-through or crossover cable can be used** to connect the module to any other 100Base-TX or 10Base-T device. See the Note on [page 20](#).
- Since the 10Base-T operation is through the 10/100Base-TX ports, if you ever want to upgrade the ports to 100Base-TX, it would be best to cable the ports initially with category 5 cable.

Note: In the module's default configuration, Auto, **either a straight-through or crossover cable can be used** to connect the module to either another Gigabit device or to a 100Base-T device. See the Note on [page 20](#).

Continued on the next page.

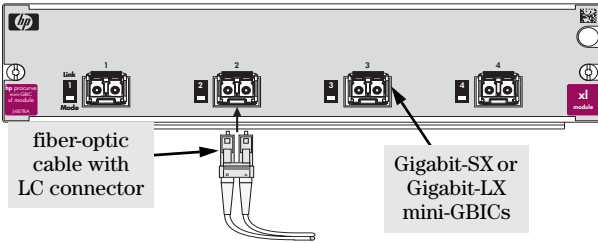
Module	Cable Type	Maximum Length
<p>mini-GBIC and the 10/100/1000-T xl Modules</p> 	<p>Gigabit-SX operation: multimode fiber-optic cables fitted with LC connectors</p> <p>Gigabit-LX operation: single-mode fiber-optic cables fitted with LC connectors. multimode fiber-optic cables may also be used—see “Fiber-Optic Cables” on page 34.</p> <p>Gigabit-LH operation: the same single-mode fiber-optic cables used for Gigabit-LX.</p>	<p>220 meters to 550 meters, depending on the cable used. See “Fiber-Optic Cables” on page 34 for more information.</p> <ul style="list-style-type: none"> • single-mode cable: 10 kilometers • multimode cable: 550 meters <p>70 kilometers</p>

Notes:

Gigabit-LX – If multimode cable is used, a **mode conditioning patch cord** may be needed — see “Mode Conditioning Patch Cord” on [page 35](#) for more information.

Gigabit-LH – Between the transmit and receive ends of the cable, at least 5dB of attenuation is required for a reliable connection. This is equivalent to 20Km of the fiber-optic cable. For distances less than 20Km, you must add attenuators to bring the total attenuation to at least 5dB. Most cable vendors carry attenuators.

100-FX MTRJ xl Module

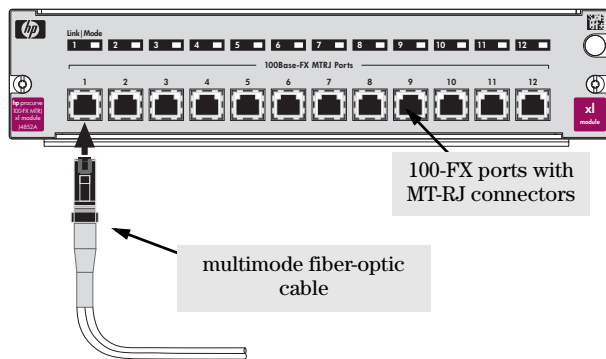

multimode fiber-optic cables fitted with MT-RJ connectors. See “Fiber-Optic Cables” on [page 34](#) for more information.

- **full-duplex connections:** 2 kilometers
- **half-duplex connections:** 412 meters

Note

Automatic Cable Sensing on Twisted-Pair Ports:

When the ports for the 10/100-TX, 100/1000-T, 10/100/1000-T, and the PoE xl Modules are in their default configuration, **Auto**, they automatically negotiate whether the ports operate as MDI or MDI-X, depending on the cable type and the connected device's operation. As a result, you can use either straight-through or crossover twisted-pair cable for all network connections to these modules.

On the 10/100-TX and PoE xl Modules, this feature is identified as **HP Auto-MDIX**; on the 100/1000-T and the 10/100/1000-T xl Modules, it is identified as **Auto MDI/MDI-X** and it is part of the IEEE 802.3ab standard. Both features operate the same.

Operation of these features depend on the port configurations being kept at **Auto**. If the configuration is changed to one of the available fixed options (for example, 100-Full Duplex), the port operates as an MDI-X port. In that case, to connect the module to another switch or hub, use a crossover cable; to connect to an end node, use a straight-through cable.

Verifying the Network Connections Are Working

Check the port LEDs for the newly-installed module to ensure the port(s) connected in the preceding step are operating correctly. Each port on the switch modules has Link and Mode LEDs near it as shown in the next illustration.

Example Link and Mode LEDs

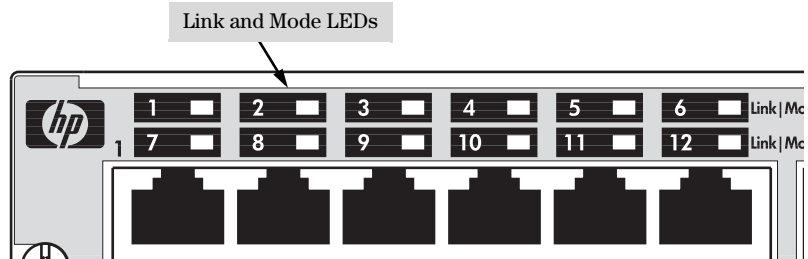

- If you have installed and connected an PoE xl module (J8161A), ensure the module is receiving power from the HP 600 RPS/EPS and the PDs are receiving PoE power from the module.

- The Link LED will be lit for each port that is connected properly to an active network device.

If the Link LED does not go on when an active network cable is connected to the port, there may be something wrong with the cable, the cable connectors, or the device at the other end of the cable. See the troubleshooting information on [page 26](#).

- If the switch Mode is set to display activity (the **Act** mode indicator LED is lit), then the Mode LED for each port that is transmitting and/or receiving packets will flicker when traffic is detected on the port.
- If the Mode is set to display full duplex (the **FDx** mode indicator LED is lit), then the Mode LED will be lit for each port that is operating in full duplex.
- If the Mode is set to display maximum link speed operation (the **Max** mode indicator LED is lit), then the Mode LED will be lit for each port that is operating at its maximum possible link speed. *For gigabit-capable ports, that speed would be 1000 Mbps (Gigabit); for 10/100 ports, that speed would be 100 Mbps.*
- If the Mode is set to display packet errors on the port (the **!** mode indicator LED is lit), then the Mode LED will flash briefly for each packet that has any of six errors, including CRC errors and late collisions.

Customizing the Port Configuration

If the slot in which you installed the module was empty the last time the switch was either rebooted or reset (or the power to the switch was cycled), then the module will use preconfigured default parameter values that will work for most networks.

The default port configurations for connection parameters are:

- **Ports Enabled:** Yes
- **Mode:**
 - **10/100-TX xl Module:** Auto — The port auto negotiates speed (10 or 100 Mbps), communication mode (half or full duplex), and MDI or MDI-X port operation. *Note: if you configure the port to one of the fixed 100 Mbps modes, the port will then operate only as an MDI-X port.*
 - **100/1000-T xl Module:** Auto — The port auto negotiates speed (1000 or 100 Mbps), communication mode (half or full duplex), and MDI or MDI-X port operation. *Note: if you configure the port to one of the fixed 100 Mbps modes, the port will then operate only as an MDI-X port.*
 - **Gigabit-SX, Gigabit-LX, and Gigabit-LH ports in mini-GBIC xl Module:** Auto — The port always operates at 1000 Mbps and full duplex. The setting is Auto for best link establishment with other devices.
 - **100-FX MTRJ xl Modules:** 100FDX — The port operates at 100 Mbps and full-duplex.
 - **10/100/1000-T xl Modules:** Auto — The port auto negotiates speed (10, 100 or 1000 Mbps), communication mode (half or full duplex), and MDI or MDI-X port operation. *Note: if you configure the port to one of the fixed 100 Mbps modes, the port will then operate only as an MDI-X port.*
 - **Dual Personality ports - (mini-GBIC ports using Gigabit-SX, Gigabit-LX, and Gigabit-LH ports):** Auto — The port always operates at 1000 Mbps and full duplex. The setting is Auto for best link establishment with other devices
- **Flow Control:** Disabled
- **Advanced features** — Spanning Tree, Trunking, Meshing, VLANs, IGMP, LACP, Routing, Class of Service, Security, and so forth: all Disabled

If necessary, configure the port(s) in the module by using the switch console or the web browser interface. For more information, see the *Management and Configuration Guide* shipped on the documentation CD that came with the switch, and the online Help provided in the console and web browser interfaces. If the default port configuration listed above is acceptable for your network, then skip this process.

Note

By default, all ports on the PoE xl module have PoE power enabled. For information regarding customizing PoE ports refer to “Power over Ethernet (PoE) Operation” in the *Management and Configuration Guide* and the *HP ProCurve PoE Planning and Implementation Guide*.

Replacing or Removing a Module

Follow these procedures to replace one module with another, or to remove a module without replacing it:

1. Remove any network cables from the ports on the module.
(If this is a PoE xl Module, also remove the PoE cable.)
2. On the module you want to remove from the switch, unscrew the retaining screws enough to disconnect them from the threaded holes in the switch.

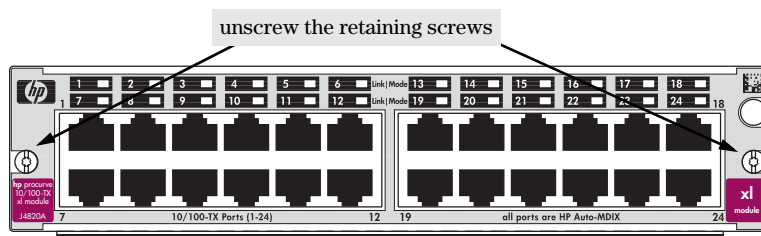

3. Grab the screws and pull the module out from the slot. It may help to brace your hands against the face of the switch and “lever” the module out from the switch slot.
4. Do one of the following:
 - If you will be installing another module in the slot, go to “Installing the Module in an Unused Slot” on [page 8](#) and begin with step 2.
 - If you will not install another module in the slot (that is, leave it empty), then re-install a slot cover plate over the empty slot opening.

Caution

For proper cooling and reduction of electromagnetic emissions, ensure a slot cover is installed on any unused slot.

5. Reset the switch, as described under “Resetting the Switch” on [page 25](#), if you are exchanging one type of module with a different type of module in the same slot (for example, replacing a 10/100-TX xl Module with a 100/1000-T xl Module).

If you are replacing a module with another one of the *same* type in the same slot, it is not necessary to reset the switch. The current configuration for ports in that slot will apply to the new module.

Resetting the Switch

Reasons for Resetting the Switch

Generally, you only need to reset the switch when it needs to recognize a change in its hardware or software (console) configuration. Some circumstances in which you will need to reset the switch are:

- Installing a module in a slot that was previously occupied by a different type of module—for example, installing a 100/1000-T xl Module in a slot that was previously used for a 10/100-TX xl Module—the switch must be reset after the new module is installed so the switch processor can properly initialize and configure the new module type.

Note

When a module is exchanged for a different type, until the switch is reset the module will not operate, the Module Status LED for the slot will continue to flash, and all the LEDs on the module will stay on continuously.

- Changing certain switch configuration parameters through the console interface. (In this case, the console provides indications when the switch must be reset for the configuration change to be activated.)

You do not need to reset the switch when:

- Installing a module in a previously unused slot.
- Replacing a module with the *same* type of module.

Methods of Resetting the Switch

You can reset the switch by any of these methods:

- pressing the Reset button on the front of the switch
- power cycling the switch (if both power supplies are being used, you will have to disconnect both power cords)
- issuing the **boot** command from the switch console CLI, or selecting the Reset or Boot option from the switch console menu, web browser interface, or ProCurve Manager

Troubleshooting

One of the primary tools for troubleshooting the switch modules are the LEDs on the front of the switch and on the modules. Refer to “LED Behavior” on [page 17](#) for a description of the normal LED behavior. Also, refer to the switch *Installation and Getting Started Guide* for more detailed troubleshooting information for the switch.

PoE LED Behavior

EPS Condition	EPS Status	EPS Fault LED	EPS Device Conn. LED	EPS Power Status LED	5300xl Fault LED	5300xl Slot LED	Module EPS Status LED	Module PoE Status LED	Module “PoE Mode” Port LEDs
EPS connected	Providing Power	Off	On	On	Off	On	On	On	On for applicable ports
EPS connected	Not Providing Power	Off	On	Off	Off	Slow Blink	Slow Blink	Off	Off
EPS connected	Oversubscribed	Off	On	On	Off	Slow Blink	Slow Blink	Slow Blink	Slow Blink on impacted ports
EPS connected	EPS Main Power Unplugged or 12V/50V Fault	Off	Off	Off	Off	On	Off	Off	Off
EPS connected	Ethernet Port Has Failure	Off	On	On	Slow Blink	Slow Blink	On	Slow Blink	Slow Blink on impacted ports
EPS connected	EPS Fault Overtemp	Blink	On	On	Off	Slow Blink	Slow Blink	*	*
EPS connected	EPS Fault Overcurrent	Blink	On	Blink	Off	Slow Blink	Slow Blink	Off	Off
EPS connected	EPS Port Failure	Blink	On	Off	Off	Slow Blink	Slow Blink	Off	Off
EPS not connected		N/A	N/A	N/A	Off	On	Off	Off	Off

On - When power is being supplied to the ports

Off - When power is not requested

Slow Blink - When power is requested, but not supplied Switch and Module

LED Error Indicators:

Fault	Self Test	Module Status	Port Link	Diagnostic Tips
Blinking [†]	Blinking [†]	Blinking [†]	Never On	❶
Blinking [†]	Blinking [†]	Blinking [†]	On briefly, then Off	❷
Off	Off	Blinking [†]	Off	❸
Blinking [†]	Blinking [†]	Blinking [†]	Blinking [†]	❹
Off	Off	Off	Fast Blinking ^{††}	❺
Off	Off	On	Off with cable connected	❻

[†] **The blinking behavior is an on/off cycle once every 1.6 seconds, approximately.**

^{††} **The fast blinking behavior is an on/off cycle once every 0.8 seconds, approximately.**

Diagnostic Tips:

See the tables on the next three pages to diagnose the LED error indicators in the previous table.

Tip Number	Problem	Solution
①	The module installed in the slot that corresponds to the letter that is blinking is an invalid module.	<p>The fact that the Link and Mode LEDs are never lit on the module indicates that it is a ProCurve Switch gl module and should not be used in your xl switch.</p>  <p>Ensure you have installed an xl module in the slot. HP ProCurve gl modules will fit in the slot, but they are not compatible with your ProCurve xl switch. Check to make sure that the module has a magenta “xl module” symbol on it.</p> <p>Remove the module from the switch and replace it with an xl module, or recover the slot with the cover plate. You can remove and replace the module without having to power down the switch. Call your HP-authorized LAN dealer, or use the electronic support services from HP to get information on supported Switch xl modules.</p>
②	The module installed in the slot that corresponds to the letter that is blinking has experienced a self test or initialization fault.	<p>The modules are all tested whenever the switch is powered on, or reset (through the Reset button on the switch, or the Reboot or Reset options in the console or web browser interface), and when they are hot swapped (installed when the switch is powered on).</p> <p>Since the Link and Mode LEDs on the module were lit at least briefly, that indicates that the module did receive power from the switch, but the subsequent download process failed. Either the module is faulty, or it is a new module type that is not yet supported by the software on the switch.</p> <p>As Hewlett-Packard introduces new modules for your HP ProCurve Switch xl, you may have to update the switch with new software that supports the module. See the module descriptions at the beginning of this guide to find out which version of the switch software is needed to support the module.</p> <p>First, verify that the switch has a version of software that supports the module that is indicating the fault. If necessary, download the new software and retest the module. The latest software can be downloaded from the HP ProCurve web site at http://www.hp.com/go/procurve, or software that supports the module is on a CD-ROM that is included with your module.</p> <p>If you have correct software installed in the switch, try removing and reinstalling the module. You can do this without having to power down the switch. When the module is reinstalled, it will be retested automatically.</p> <p>If the fault indication reoccurs, the module is faulty. Remove the module from the switch and replace it with another module, or recover the slot with the cover plate. Call your HP-authorized LAN dealer, or use the electronic support services from HP to get assistance. See the Customer Support/Warranty card for more information.</p>

Tip Number	Problem	Solution
3	A module was installed in the slot that is a different type than the previously installed module, and the switch has not yet been reset.	<p>When you “hot swap” modules in the switch slot, if you install a different module type than the one that was previously installed in the slot, you must reset the switch so the switch processor can properly initialize and configure the new module type. The blinking LED informs you that this change of module types has occurred. The module will not work properly until the switch is reset, as indicated by all the module’s LEDs staying on until the switch is reset.</p> <p>See “Resetting the Switch” on page 25.</p>
4	The network port for which the Link LED is blinking has experienced a self test or initialization failure.	<p>During the module self test (described in item 1 above), each network port is also tested. If the port self test fails, the individual port is not usable, but the rest of the ports on the module, which have passed their self test, will continue to operate normally.</p> <p>If the error has occurred on a mini-GBIC that you have installed in the mini-GBIC xl Module, make sure that it is one of the supported mini-GBICs. The HP ProCurve mini-GBICs that are supported, as of the printing of this manual, are listed on page 1. Use only the supported HP ProCurve mini-GBICs. If it is a supported mini-GBIC, it may have failed. Try removing and reinstalling the mini-GBIC and it will be tested again. If the fault indication reoccurs, the mini-GBIC is faulty and must be replaced.</p> <p>If the error has occurred on a port that contains a known valid mini-GBIC or on a twisted-pair port or 100-FX port on one of the other modules, try removing and reinstalling the module. If the port fault indication reoccurs, and you need to be able to use the port, you will have to replace the module. In the mean time, all the other ports on the module will operate normally.</p>
5	The network port for which the Link LED is blinking has been disabled because port security has been configured on the switch and a security violation has been detected on the port.	<p>For the Port Security feature, you can configure the switch so that whenever a security violation is detected on a port, the switch will disable the port. When a port is disabled by this feature, the port Link LED will be continuously flashed at the fast rate of 0.8 seconds per cycle. The blinking continues until you clear the security violation through the switch console. In the console, you can view the identity of the connected device that committed the security violation.</p> <p>Once the security violation is cleared, you must re-enable the port through the console.</p> <p>For more information on the Port Security feature, see the <i>Management and Configuration Guide</i> that is on the documentation CD-ROM that came with your switch.</p>

Tip Number	Problem	Solution
6	The network connection is not working properly.	<p>Try the following procedures:</p> <ul style="list-style-type: none">• For the indicated port, verify both ends of the cabling, at the switch and the connected device, are securely connected.• Verify the connected device and switch are both powered <i>on</i> and operating correctly.• Verify you have used the correct cable type for the connection. See “Cables” on page 33 for the correct cable specifications.<ul style="list-style-type: none">– for any of the twisted-pair connections, in the default configuration (Auto), either a straight-through or a crossover cable can be used and the switch will automatically adjust its operation. See the “Automatic Cable Sensing” description on page 20 for more information. <hr/> <p><i>Note: If the module configuration is changed to one of the fixed configuration options though (for example, 100-Full Duplex), then the port operates as MDI-X only and the correct type of cable must be used. In general, for connecting to an end node (MDI port), use straight-through cable; for connecting to MDI-X ports on hubs or other switches, use crossover cable.</i></p> <hr/> <ul style="list-style-type: none">– For a 1000 Mbps connection on twisted-pair cable, verify the network cabling complies with the IEEE 802.3ab standard. The cable should be installed according to the ANSI/TIA/EIA-568-A-5 specifications. Cable testing should comply with the stated limitations for Attenuation, Near-End Crosstalk, Far-End Crosstalk, Equal-Level Far-End Crosstalk (ELFEXT), Multiple Disturber ELFEXT, and Return Loss.<p>The cable verification must include all patch cables from any end devices, including the switch, to any patch panels in the cabling path.</p>– for fiber-optic connections, verify the transmit port on the switch is connected to the receive port on the connected device, and the switch receive port is connected to the transmit port on the connected device. Also verify that the cables comply with the specifications shown on page 34. <ul style="list-style-type: none">• Verify the port has not been disabled through a switch configuration change.<p>You can use the console interface, or, if you have configured an IP address on the switch, use the web browser interface, or ProCurve Manager network management software to determine the state of the port and re-enable the port if necessary.</p>• Verify the switch port configuration matches the configuration of the connected device. For example, if the switch port is configured as “Auto”, the port on the connected device also MUST be configured as “Auto”. If the configurations don’t match, the results could be a very unreliable connection or no link at all.• If the other procedures don’t resolve the problem, try using a different port or a different cable.

Customer Support Services

If you are having any trouble with your module or switch, Hewlett-Packard offers support 24 hours a day, seven days a week through the use of a number of automated electronic services. See the Customer Support/Warranty booklet that came with your switch for information on how to use these services to get technical support. The HP networking products World Wide Web site, <http://www.hp.com/go/procurve> also provides up-to-date support information. Additionally, your HP-authorized network reseller can also provide you with assistance, both with services they offer and with services offered by HP.

Specifications

Environmental

	Operating	Non-Operating
Temperature:	0°C to 40°C (32°F to 104°F)	-40°C to 70°C (-40°F to 158°F)
Relative humidity: (non-condensing)	15% to 95% at 40°C (104°F)	15% to 90% at 65°C (149°F)
Maximum altitude:	4.6 Km (15,000 ft)	4.6 Km (15,000 ft)

Lasers

The Gigabit-SX, Gigabit-LX, and Gigabit-LH mini-GBICs, which can be installed in the mini-GBIC and PoE xl Modules, are Class 1 Laser Products.
Laser Klasse 1

These mini-GBICs comply with IEC 825-2: 1993.

Connectors

Twisted-Pair

- **10/100Base-TX RJ-45** – On the **10/100-TX xl Module**.
They are compatible with the IEEE 802.3 10Base-T and 802.3u 100Base-TX standards and accepts the 10 Mbps or 100 Mbps cables listed on the next page.
- **100/1000Base-T RJ-45** – On the **100/1000-T and the 10/100/1000-T xl Modules**.
They are compatible with the IEEE 802.3u 100Base-TX and IEEE 802.3ab 1000Base-T standards, and accepts the 100 Mbps or 1000 Mbps cables listed on the next page.
- **1000Base-T RJ-45** – On the **1000Base-T mini-GBIC**.
They are compatible with the IEEE 802.3ab 1000Base-T standards, and accepts the 1000 Mbps cables listed on the next page.

Fiber-Optic

- **100Base-FX MTRJ** – On the **100-FX xl Module**.
Transmit at 1310 nm wavelength, and are compatible with the IEEE 802.3u 100Base-FX standard. They accept the multimode fiber-optic cables for 100Base-FX described on [page 34](#).
- **Gigabit-SX LC** – On the **Gigabit-SX mini-GBIC**.
Transmits at 850 nm wavelength, and is compatible with the IEEE 802.3z Gigabit-SX standard. It accepts the low metal content, multimode fiber-optic cables for Gigabit-SX described on [page 34](#).
- **Gigabit-LX LC** – On the **Gigabit-LX mini-GBIC**.
Transmits at 1310 nm wavelength, and is compatible with the IEEE 802.3z Gigabit-LX standard. It accepts the low metal content, single-mode or multimode fiber-optic cables for Gigabit-LX described on [page 34](#).
- **Gigabit-LH LC** – On the **Gigabit-LH mini-GBIC**.
Transmits at 1310 nm wavelength, and accepts the low metal content, single-mode fiber-optic cables for Gigabit-LH described on [page 34](#).

Cables

Twisted-Pair Cables

Port Type	Cable Specifications	Maximum Length
10 Mbps Operation	Category 3, 4, or 5 100-ohm balanced unshielded twisted-pair (UTP) or shielded twisted-pair (STP) cable, complying with IEEE 802.3 10Base-T specifications, fitted with RJ-45 connectors	100 meters
100 Mbps Operation	Category 5 100-ohm balanced UTP or STP cable, complying with IEEE 802.3u 100Base-TX specifications, fitted with RJ-45 connectors	100 meters
1000 Mbps Operation	Category 5e 100-ohm balanced UTP or STP cable, complying with IEEE 802.3ab 1000Base-T specifications, fitted with RJ-45 connectors <i>(please see “Note on 1000Base-T Cable Requirements”, below)</i>	100 meters

Note on 1000Base-T Cable Requirements. The Category 5 networking cables that work for 100Base-TX connections should also work for 1000Base-T, but for the most robust connections you should use cabling that complies with the Category 5e (or better) specifications, as described in Addendum 5 to the TIA-568-A standard (ANSI/TIA/EIA-568-A-5).

Because of the increased speed provided by 1000Base-T (Gigabit-T), network cable quality is more important than for either 10Base-T or 100Base-TX. Cabling plants being used to carry 1000Base-T networking must comply with the IEEE 802.3ab standards. In particular, the cabling must pass tests for Attenuation, Near-End Crosstalk (NEXT), and Far-End Crosstalk (FEXT). Additionally, unlike the cables for 100Base-TX, the 1000Base-T cables must pass tests for Equal-Level Far-End Crosstalk (ELFEXT), Multiple Disturber ELFEXT, and Return Loss.

When testing your cabling, be sure to include the patch cables that connect the switch and other end devices to the patch panels on your site. The patch cables are frequently overlooked when testing cable and they must also comply with the cabling standards.

Fiber-Optic Cables

Port Type	Cable Specifications	Connector Type	Maximum Length
100Base-FX	62.5/125 μm or 50/125 μm (core/cladding) diameter, graded-index, low metal content, multimode fiber-optic cables, complying with the ITU-T G.651 and ISO/IEC 793-2 Type A1b or A1a respectively.	MT-RJ	<ul style="list-style-type: none"> • full-duplex connections: 2 kilometers • half-duplex connections: 412 meters
Gigabit-SX	62.5/125 μm or 50/125 μm (core/cladding) diameter, graded-index, low metal content, multimode fiber-optic cables, complying with the ITU-T G.651 and ISO/IEC 793-2 Type A1b or A1a respectively.	LC	<ul style="list-style-type: none"> • 62.5 mm cable: <ul style="list-style-type: none"> – 160 MHz*km = 220 meters – 200 MHz*km = 275 meters • 50 mm cable: <ul style="list-style-type: none"> – 400 MHz*km = 500 meters – 500 MHz*km = 550 meters
Gigabit-LX	9/125 μm (core/cladding) diameter, 1310 nm, low metal content, single mode fiber-optic cables, complying with the ITU-T G.652 and ISO/IEC 793-2 Type B1 standards. OR the multimode fiber-optic cables listed for Gigabit-SX.	LC	<ul style="list-style-type: none"> • single-mode cable: 10 kilometers • multimode cable: 550 meters <p>Note: To use multimode cables for Gigabit-LX, a mode conditioning patch cord may be needed — see “Mode Conditioning Patch Cord for Gigabit-LX” on page 35 for more information.</p>
Gigabit-LH	9/125 μm (core/cladding) diameter, 1550 nm, low metal content, single mode fiber-optic cables, complying with the ITU-T G.652 and ISO/IEC 793-2 Type B1 standards.	LC	70 kilometers
	<p>Note: Between the transmit and receive ends of the cable, at least 5dB of attenuation is required for a reliable connection. This is equivalent to 20Km of the fiber-optic cable. For distances less than 20Km, you must add attenuators to bring the total attenuation to at least 5dB. Most cable vendors carry attenuators.</p>		

Mode Conditioning Patch Cord for Gigabit-LX

The following information applies to installations in which multimode fiber-optic cables are connected to a Gigabit-LX port.

Unlike Gigabit-SX, which connects to only multimode fiber-optic cabling, Gigabit-LX can use either single-mode or multimode cable. Multimode cable has a design characteristic called “Differential Mode Delay”, which requires that the transmission signals be “conditioned” to compensate for the cable design and thus prevent resulting transmission errors. Since Gigabit-SX is designed to operate only with multimode cable, Gigabit-SX mini-GBICs can provide that transmission conditioning internally.

Gigabit-LX mini-GBICs, since they are designed to operate with both single-mode and multimode cable, do not provide the transmission conditioning internally. Thus, under certain circumstances, depending on the cable used and the lengths of the cable runs, an external **Mode Conditioning Patch Cord** may need to be installed between the Gigabit-LX transmitting device and the multimode network cable to provide the transmission conditioning.

If you experience a high number of transmission errors on the Gigabit-LX ports, usually CRC or FCS errors, you may need to install one of these patch cords between the Gigabit-LX port in your switch and your multimode fiber-optic network cabling, *and between the Gigabit-LX transmission device and the network cabling at the other end of the multimode fiber-optic cable run. A patch cord must be installed at both ends.*

The patch cord consists of a short length of single-mode fiber cable coupled to graded-index multimode fiber cable on the transmit side, and only multimode cable on the receive side. The section of single-mode fiber is connected in such a way that it minimizes the effects of the differential mode delay in the multimode cable.

Note

Most of the time, if you are using good quality graded-index multimode fiber cable that adheres to the standards listed on [page 34](#), there should not be a need to use mode conditioning patch cords in your network. This is especially true if the fiber runs in your network are relatively short.

If you are using *single-mode* fiber-optic cabling in your network, there is no need to use mode conditioning patch cords. Connect the single-mode network cable directly to the Gigabit-LX mini-GBIC.

Installing the Patch Cord

As shown in the illustration below, connect the patch cord to the Gigabit-LX mini-GBIC with the section of single-mode fiber plugged in to the Tx (transmit) port. Then, connect the other end of the patch cord to your network cabling patch panel, or directly to the network multimode fiber.

If you connect the patch cord directly to the network cabling, you may need to install a **female-to-female adapter** to allow the cables to be connected together.

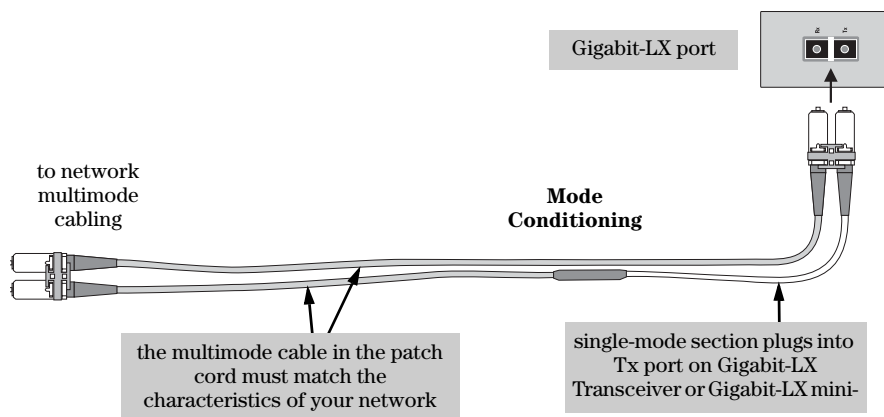

Ensure you purchase a patch cord that has LC connectors on the end that connects to the Gigabit-LX mini-GBIC, and has multimode fibers that match the characteristics of the multimode fiber in your network.

Recommended Patch Cords

Hewlett-Packard maintains a list of recommended Mode Conditioning Patch Cords that have been tested and verified to operate correctly with the HP ProCurve Gigabit-LX Transceiver and HP ProCurve Gigabit-LX LC mini-GBIC.

The list is on the HP ProCurve web site, <http://www.hp.com/go/procurve>, in the Technical Support section.

EMC Regulatory Statements

U.S.A.

FCC Class A

This equipment has been tested and found to comply with the limits for a Class A digital device, pursuant to Part 15 of the FCC Rules. These limits are designed to provide reasonable protection against interference when the equipment is operated in a commercial environment. This equipment generates, uses, and can radiate radio frequency energy and, if not installed and used in accordance with the instruction manual, may cause interference to radio communications. Operation of this equipment in a residential area may cause interference in which case the user will be required to correct the interference at his own expense.

Canada

This product complies with Class A Canadian EMC requirements.

Australia/New Zealand



This product complies with Australia/New Zealand EMC Class A requirements.

Japan

VCCI Class A

この装置は、情報処理装置等電波障害自主規制協議会（VCCI）の基準に基づくクラスA情報技術装置です。この装置を家庭環境で使用すると電波妨害を引き起こすことがあります。この場合には使用者が適切な対策を講ずるよう要求されることがあります。

Korea

사용자 안내문 : A 급기기

이 기기는 업무용으로 전자파 적합등록을 받은 기기 이오니, 판매자 또는 사용자는 이점을 주의하시기 바라며, 만약 잘못 구입하셨을 때에는 구입한 곳에서 비업무용으로 교환하시기 바랍니다.

Taiwan

警告使用者：這是甲類的資訊產品，在居住的環境中使用時，可能會造成射頻干擾，在這種情況下，使用者會被要求採取某些適當的對策。

European Community Declaration of Conformity

These products are designed for operation with the HP ProCurve switches that have xl module slots. Please see the Declarations of Conformity included in the Installation Guides for those products.

— *This page is intentionally unused.* —

— *This page is intentionally unused.* —

— *This page is intentionally unused.* —



Technical information in this document is subject to change without notice.

©Copyright Hewlett-Packard Company, 2001, 2005. All rights reserved. Reproduction, adaptation, or translation without prior written permission is prohibited except as allowed under the copyright laws.

Product of Singapore
March 2005

Manual Part Number
5991-2130

