



## Installation and Getting Started Guide

# ProCurve Wireless Access Point 530



Power over Ethernet Devices



---

ProCurve

Wireless Access Point 530

---

Installation and Getting Started Guide

© Copyright 2006 Hewlett-Packard Development Company, L.P. The information contained herein is subject to change without notice.

This document contains proprietary information, which is protected by copyright. No part of this document may be photocopied, reproduced, or translated into another language without the prior written consent of Hewlett-Packard.

### Publication Number

5991-2192  
May 2006

### Applicable Products

ProCurve Wireless Access Point 530 NA	(J8986A)
ProCurve Wireless Access Point 530 WW	(J8987A)

### Disclaimer

HEWLETT-PACKARD COMPANY MAKES NO WARRANTY OF ANY KIND WITH REGARD TO THIS MATERIAL, INCLUDING, BUT NOT LIMITED TO, THE IMPLIED WARRANTIES OF MERCHANTABILITY AND FITNESS FOR A PARTICULAR PURPOSE. Hewlett-Packard shall not be liable for errors contained herein or for incidental or consequential damages in connection with the furnishing, performance, or use of this material.

The only warranties for HP products and services are set forth in the express warranty statements accompanying such products and services. Nothing herein should be construed as constituting an additional warranty. HP shall not be liable for technical or editorial errors or omissions contained herein.

Hewlett-Packard assumes no responsibility for the use or reliability of its software on equipment that is not furnished by Hewlett-Packard.

### Warranty

See the Customer Support/Warranty booklet included with the product.

A copy of the specific warranty terms applicable to your Hewlett-Packard products and replacement parts can be obtained from your HP Sales and Service Office or authorized dealer.

---

### Safety

Before installing and operating these products, please read the “Installation Precautions” in chapter 2, “Installing the Access Point 530”, and the safety statements in appendix C, “Safety and EMC Regulatory Statements”.

---

---

# Contents

## 1 Introducing the ProCurve Wireless Access Point 530

<b>Top of the Access Point</b> .....	1-3
LEDs .....	1-4
<b>Back of the Access Point</b> .....	1-5
Back Panel Covers .....	1-5
Antennas .....	1-5
Console Port .....	1-6
Network Port .....	1-6
Power Connector .....	1-6
Reset Button .....	1-7
Clear Button .....	1-8
Auxiliary Port .....	1-8
<b>Access Point Features</b> .....	1-9

## 2 Installing the Access Point 530

<b>Included Parts</b> .....	2-1
<b>Installation Procedures</b> .....	2-2
Summary .....	2-2
Installation Precautions: .....	2-3
1. Prepare the Installation Site .....	2-4
2. Verify the Access Point Completes Initialization .....	2-5
LED Behavior: .....	2-6
3. Mount the Access Point .....	2-7
Wall Mounting .....	2-7
Standard Electrical Box Mounting .....	2-9
Suspended Ceiling Mounting .....	2-10
Horizontal Surface Mounting .....	2-12
4. Connect the Access Point to a Power Source .....	2-12
5. Connect the Network Cable .....	2-13
Using the RJ-45 Connectors .....	2-13
6. (Optional) Connect External Antennas to the Access Point .....	2-13

7. (Optional) Connect a Console to the Access Point 530 . . . . .	2-14
Terminal Configuration . . . . .	2-14
Direct Console Access . . . . .	2-15
<b>Sample Network Topologies</b> . . . . .	2-17
Infrastructure Wireless LAN . . . . .	2-18
Infrastructure Wireless LAN with Roaming . . . . .	2-19
Wireless Distribution System (WDS) Bridge . . . . .	2-21
Wireless Distribution System (WDS) Repeater . . . . .	2-23
<b>3 Getting Started With Access Point Configuration</b>	
Recommended Minimal Configuration . . . . .	3-1
Using the Command Line Interface . . . . .	3-2
To Set the Manager User Name and Password . . . . .	3-2
To Set the Access Point's IP Address . . . . .	3-3
To Set the Access Point's Country Code . . . . .	3-4
To Configure Radio Settings . . . . .	3-4
Where to Go From Here . . . . .	3-8
<b>Using the IP Address for Remote Access Point Management</b> . . . . .	3-9
Starting a Telnet Session . . . . .	3-9
Starting an SSH Session . . . . .	3-10
Starting a Web Browser Session . . . . .	3-10
<b>4 Using an External Antenna with the Access Point 530</b>	
<b>External Antenna Options</b> . . . . .	4-2
<b>Installation Procedures</b> . . . . .	4-3
1. Plan the Installation . . . . .	4-3
2. Mount the Antenna . . . . .	4-4
3. Connect Pigtail Cables to the Access Point . . . . .	4-4
4. Configure the Antenna Mode and Type . . . . .	4-6
Setting the Antenna Mode and Type Using the CLI . . . . .	4-6
Setting the Antenna Mode and Type Using the Web Interface . . . . .	4-6

## **5 Troubleshooting**

<b>Basic Troubleshooting Tips</b> .....	5-1
<b>Diagnosing with the LEDs</b> .....	5-3
<b>Proactive Networking</b> .....	5-5
<b>Hardware Diagnostic Tests</b> .....	5-6
Testing the Access Point by Resetting It .....	5-6
Checking the Access Point's LEDs .....	5-6
Checking Event Messages .....	5-6
Testing Twisted-Pair Cabling .....	5-7
Testing Access Point-to-Device Network Communications .....	5-7
Testing End-to-End Network Communications .....	5-7
<b>Restoring Custom and Factory Default Configurations</b> .....	5-8
<b>Downloading New Access Point Software</b> .....	5-10
<b>HP Customer Support Services</b> .....	5-10
Before Calling Support .....	5-10

## **A Specifications**

Physical .....	A-1
Electrical .....	A-1
Environmental .....	A-1
Connectors .....	A-2
Safety .....	A-2
EMC Compliance (Class B) .....	A-2
Radio Signal Certification .....	A-2
Immunity .....	A-2
Wireless .....	A-3
Receiver Sensitivity .....	A-4

## **B Access Point Port and Network Cables**

Access Point Ports .....	B-1
Twisted-Pair Cables .....	B-1

<b>Twisted-Pair Cable/Connector Pin-Outs</b> .....	B-2
Straight-Through Twisted-Pair Cable for 10 Mbps or 100 Mbps Network Connections .....	B-3
Cable Diagram .....	B-3
Pin Assignments .....	B-3
Crossover Twisted-Pair Cable for 10 Mbps or 100 Mbps Network Connection .....	B-4
Cable Diagram .....	B-4
Pin Assignments .....	B-4

## **C Safety and EMC Regulatory Statements**

<b>Safety Information</b> .....	C-1
<b>EMC Regulatory Statements</b> .....	C-9

## **D Recycle Statements**

<b>Waste Electrical and Electronic Equipment (WEEE) Statements</b>	D-1
--	-----

## **Index**

# Introducing the ProCurve Wireless Access Point 530

---

The ProCurve Wireless Access Point 530 is an enterprise-class, dual-radio 802.11b/g and 802.11a/b/g access point that offers maximum flexibility in deployment and optimum throughput for high-density usage areas.

The access point provides comprehensive security and management features and is capable of supporting all types of wireless stations in the same coverage area. The unit includes internal diversity antennas for both radios and also connectors for attaching a variety of external antenna options. Mounting options for the unit include horizontal surface, wall, suspended ceiling T-rail, and plenum space.

**ProCurve Wireless Access Point 530 NA (J8986A)**  
**ProCurve Wireless Access Point 530 WW (J8987A)**



Throughout this manual, this access point will be abbreviated as the Access Point 530.

The Access Point 530 has one 10/100Base-TX RJ-45 port. This port also supports Power over Ethernet (PoE) based on the IEEE 802.3af standard. The access point supports wireless connectivity at speeds up to 54 Mbps based on the IEEE 802.11g and IEEE 802.11a standards.

This access point is designed to be used primarily for connecting wireless stations to an enterprise network. This access point allows wireless stations to connect directly to each other, or to connect to other computers or network resources located on the wired network.

This chapter describes your Access Point 530 including:

- Top and back of the access point
- Access point features

# Top of the Access Point

ProCurve Wireless Access Point 530

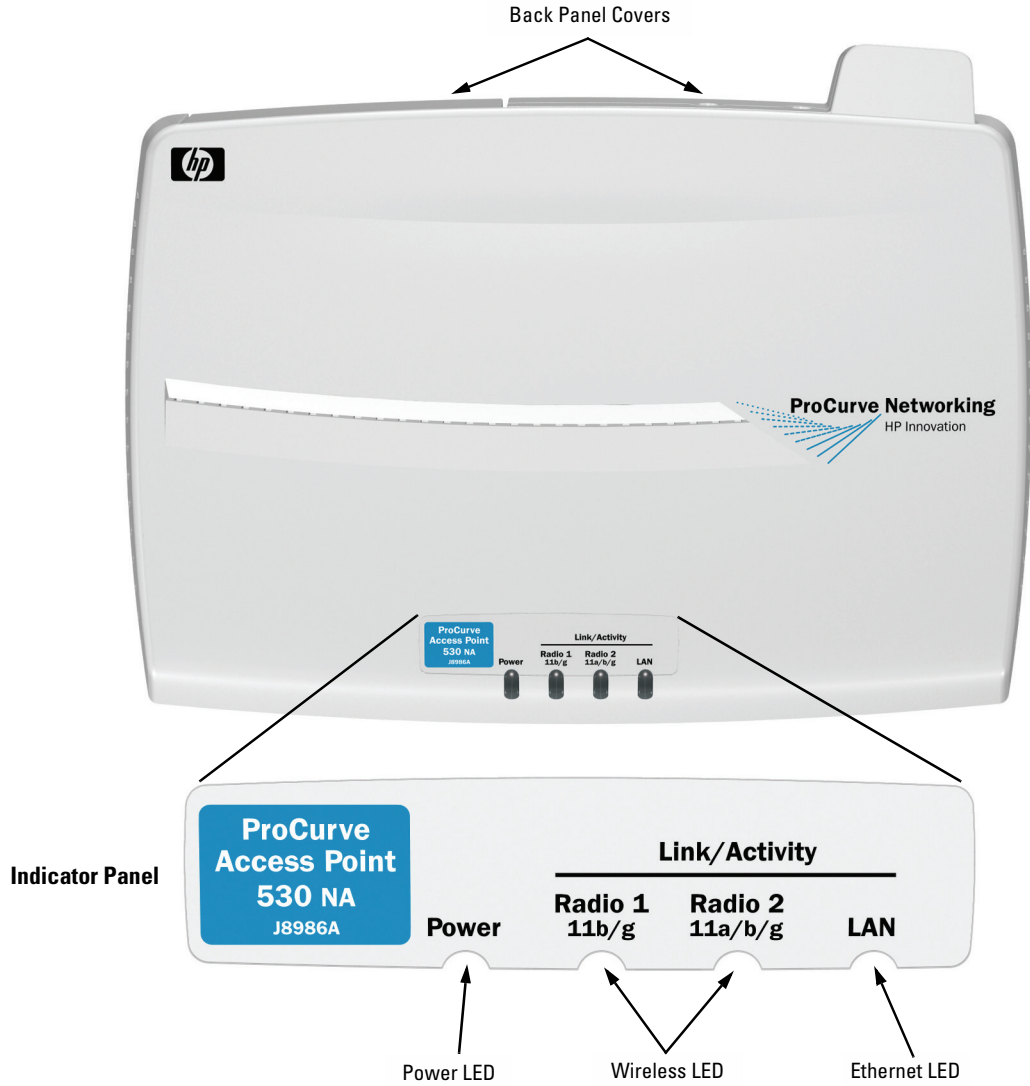

## LEDs

**Table 1-1. Access Point LEDs**

Access Point LEDs	State	Meaning
Power (green)	On	The access point is receiving power.
	Off	The access point is NOT receiving power.
LAN (green)	Off	The RJ-45 port has no network cable connected, or is not receiving a link signal.
	Blinking or On	The RJ-45 port has a link indication from a 10 Mbps or 100 Mbps device and is transmitting or receiving traffic. The LED blinking rate is proportional to the traffic rate. If there is no traffic, the blinking rate will be once every five seconds. As the traffic rate increases, the blinking rate also increases until the LED is solid on, which indicates there no available bandwidth on the port.
Radio 1 (11b/g) Radio 2 (11a/b/g) (green)	Off	The wireless interface is disabled, either through the access point console or the Web browser interface.
	Blinking or On	The wireless interface is enabled and transmitting or receiving traffic. The LED blinking rate is proportional to the traffic rate. If there is no traffic, the blinking rate will be once every five seconds. As the traffic rate increases, the blinking rate also increases until the LED is solid on, which indicates there no available bandwidth on the interface.

## Back of the Access Point

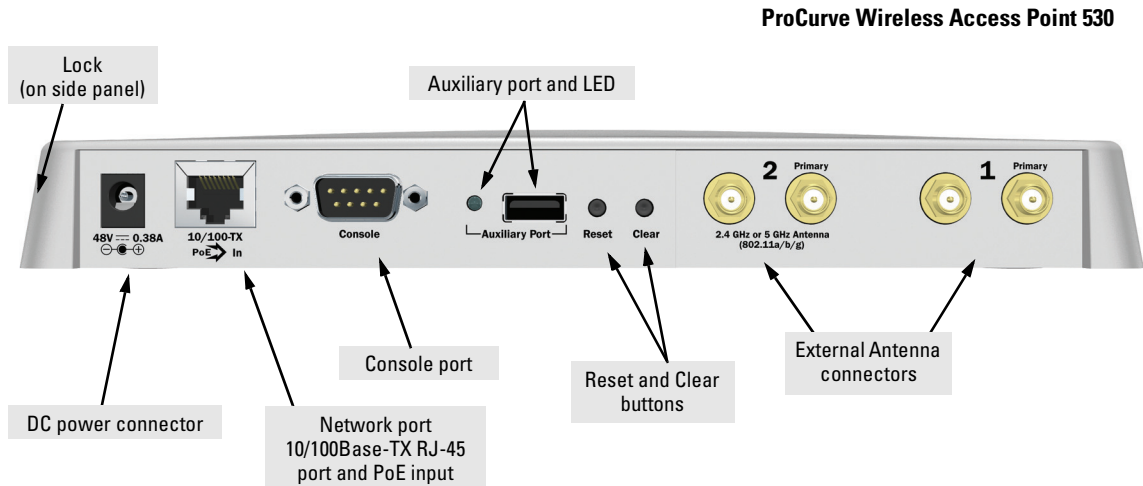

### Back Panel Covers

The access point's ports and connectors on the back of the unit can be protected by two removable plastic covers. One covers the Console port, Clear and Reset buttons, RJ-45 port, and DC power connector, while allowing twisted-pair and power cables to pass through. The other cover protects the external antenna connectors when they are not in use.

### Antennas

The access point includes internal diversity antennas for wireless communications. A diversity antenna system uses two identical antennas to receive and transmit signals, helping to avoid multipath fading effects. When receiving, the access point checks both antennas and selects the one with the strongest signal. When transmitting, it will continue to use the antenna previously selected for receiving. The access point never transmits from both antennas at the same time.

The access point also supports connectors for various external antenna options that offer extended radio range and specific radio coverage patterns. For further information, see chapter 4, “Using an External Antenna with the Access Point 530”.

## Lock

The access point includes a Kensington security slot on the side panel, marked with the lock symbol (  ). You can prevent unauthorized removal of the access point by wrapping the Kensington security cable (not provided) around an unmovable object, inserting the lock into the slot, and turning the key.

## Console Port

This port connects a console to the access point using a serial cable. This connection is described under “Connect a Console to the Access Point” in chapter 2, “Installing the Access Point 530”. The console can be a PC or workstation running a VT-100 terminal emulator, or a VT-100 terminal.

## Network Port

The access point includes one 10/100Base-TX port. This port uses the “HP Auto MDIX” feature, which means that you can use either straight-through or crossover twisted-pair cables to connect the access point to a switch or workstation.

Refer to the following section for information on supplying power to the access point through its RJ-45 port from a network device, such as a switch, that provides Power over Ethernet (PoE).

## Power Connector

The Access Point 530 does not have a power switch; it is powered on when connected to the AC power adapter, and the power adapter is connected to an active AC power source. The access point's power adapter automatically adjusts to any voltage between 100–240 volts and either 50 or 60 Hz. There are no voltage range settings required.

---

### Caution

---

Use only the AC power adapter supplied with the access point. Use of other adapters, including adapters that came with other ProCurve Networking products, may result in damage to the equipment.

The access point may also receive Power over Ethernet (PoE) from a switch or other network device that supplies power over the network cable based on the IEEE 802.3af standard.

Note that if the access point is connected to a PoE source device and also connected to a local power source through the AC power adapter, PoE will be disabled.

## Reset Button

This button is used to reset the hardware or restore the factory defaults:

- **To Reset the Access Point While it is Powered On** – When the Reset button is pressed for about one second all the LEDs turn off, then after another second the LEDs start to blink rapidly. Releasing the button when the LEDs are blinking rapidly clears any temporary error conditions that may have occurred and restarts the access point initialization.
- **To Restore Custom Default Configuration** – When pressed with the Clear button in a specific pattern, any configuration changes you may have made through the access point console or the Web browser interface are removed, and the customer-specified default configuration is restored to the access point. For the specific method to restore the customer default configuration, see “Restoring Custom and Factory Default Configurations” in chapter 5, “Troubleshooting” of this guide.
- **To Restore Factory Default Configuration** – When pressed with the Clear button in a specific pattern, any configuration changes you may have made through the access point console or the Web browser interface are removed, and the factory default configuration is restored to the access point. For the specific method to restore the factory default configuration, see “Restoring Custom and Factory Default Configurations” in chapter 5, “Troubleshooting” of this guide.

---

### Note

The system, password, custom default, and factory default reset functions can be disabled by the access point’s software. For more information, see the *Management and Configuration Guide*, which is on the Documentation CD-ROM that came with your access point and also on the ProCurve Networking Web site at <http://www.procurve.com>.

---

## Clear Button

This button is used for these purposes:

- **Deleting the Password** - When pressed by itself for at least one second, the button resets the Manager password to the factory default setting for all of the access point's interfaces. Use this feature if you have misplaced the password and need management access.
- **To Restore Custom Default Configuration** – When pressed with the Reset button in a specific pattern, any configuration changes you may have made through the access point console or the Web browser interface are removed, and the customer-specified default configuration is restored to the access point. For the specific method to restore the customer default configuration, see “Restoring Custom and Factory Default Configurations” in chapter 5, “Troubleshooting” of this guide.
- **Restoring Factory Default Configuration** - When pressed with the Reset button in a specific pattern, any configuration changes you may have made through the console, the Web browser interface, and SNMP management are removed, and the factory default configuration is restored to the access point. For the specific method to restore the factory default configuration, see “Restoring Custom and Factory Default Configurations” in chapter 5, “Troubleshooting” of this guide.

## Auxiliary Port

The Auxiliary port is reserved for future use.

---

## Access Point Features

The wireless features of the Access Point 530 include:

- dual-radio design with IEEE 802.11b/g and IEEE 802.11a/b/g radios
- supports up to 16 Service Set Identifier (SSID) interfaces
- independent security and VLAN settings per SSID interface
- supports up to 256 wireless stations per radio interface
- IEEE 802.11a/b/g compliant – interoperable with multiple vendors
- precise control over signal transmission power and data rate
- advanced security through 64/128/152-bit WEP encryption, Wi-Fi Protected Access (WPA and WPA2), IEEE 802.1X, remote authentication via a RADIUS server, and MAC address filtering features to protect your sensitive data and authenticate only authorized users to your network
- remote logging of system messages
- time synchronization via SNTP server for message logs
- wireless bridging between access points
- neighbor access point detection
- Quality of Service (QoS) support through Wi-Fi Multimedia (WMM) and Spectralink Voice Priority (SVP)
- auto channel selection – simplifies deployment by testing all available channels and selecting the best channel based on signal-to-noise ratio
- international country configuration – select the appropriate country and the access point automatically configures radio operation to match regulatory requirements (model J8987A only)

The other basic features of the Access Point 530 include:

- one 10/100Base-TX RJ-45 port
- supports Power over Ethernet based on the IEEE 802.3af standard
- full-duplex operation for the 10/100 RJ-45 port
- easy management of the access point through several available interfaces:
  - **console interface**—a full featured, easy to use, VT-100 terminal interface that is especially good for out-of-band access point management and for Telnet or Secure Shell access to the access point
  - **Web browser interface**—an easy to use built-in graphical interface that can be accessed from common Web browsers (includes support for secure HTTP connections)

- **SNMP**—a network management application such as HP ProCurve Manager can manage the access point via the Simple Network Management Protocol (SNMP) from a network management station (supports SNMP versions 1, and 2c)
  - support for IEEE 802.1Q-compliant VLANs (as specified for each station in the RADIUS server) so that wireless stations can join the appropriate logical grouping for the network user's needs
  - support for Identity Driven Management and RADIUS assigned VLANs
  - RADIUS Accounting for logging user activity on the network
  - support for many advanced features to enhance network performance—for a description, see the *Management and Configuration Guide*, which is on the Documentation CD-ROM that is included with your access point.
  - download of new access point software for product enhancements or software updates
  - upload and download of access point configuration files

# Installing the Access Point 530

---

The Access Point 530 is easy to install. It comes with an accessory kit that includes a bracket for mounting the access point on a wall or to a suspended ceiling T-rail. The bracket is designed to allow mounting the access point in a variety of locations and orientations.

This chapter shows you how to install your Access Point 530.

---

## Included Parts

The Access Point 530 has the following components shipped with it:

- *ProCurve Wireless Access Point 530 Installation and Getting Started Guide* (5991-2192), this manual
- *ProCurve Product Documentation CD-ROM*  
(contains PDF file copies of the documentation for the Access Point 530, including the *Management and Configuration Guide*)
- Customer Support/Warranty booklet
- Accessory kit (5070-1657)
  - four 5/8-inch number 12 wood screws to attach the access point to a wall
  - four plastic wall plugs for mounting on a brick or concrete wall
  - four rubber feet
- Mounting bracket (5188-4682)
- AC power adapter (5188-3767)
- AC power cord, one of the following:

United States/Canada/Mexico	8120-0740
Continental Europe	8121-0731
United Kingdom/Hong Kong/Singapore	8121-0739
Australia/New Zealand	8121-0730
Japan	8121-0736
China	8121-0742
Denmark	8121-0733
Switzerland	8121-0738

# Installation Procedures

## Summary

Follow these easy steps to install your access point. The rest of this chapter provides details on these steps.

1. **Prepare the installation site (page 2-4).** Make sure that the physical environment into which you will be installing the access point is properly prepared, including having the correct network cabling ready to connect to the access point and having an appropriate location for the access point. *Please see page 2-2 for some installation precautions.*
2. **Verify that the access point completes its system initialization (page 2-5).** This is a simple process of plugging the access point into a power source, or connecting it to a switch that provides Power over Ethernet, and observing that the LEDs on the access point's top panel indicate correct access point operation.
3. **Mount the access point (page 2-7).** The Access Point 530 can be mounted on a wall, on a suspended ceiling T-rail, or on a horizontal surface.
4. **Connect power to the access point (page 2-12).** Once the access point is mounted, plug it into a nearby main power source, or connect it to a switch that provides Power over Ethernet.
5. **Connect to the network (page 2-13).** Using the appropriate network cable, connect the access point to a network connection point, such as a switch. The network connection can also be used to provide power to the access point through its PoE feature.
6. **Connect a console to the access point (optional—page 2-14).** You may wish to modify the access point's configuration, for example, to configure an IP address so it can be managed using a Web browser or through a Telnet session. Configuration changes can be made easily by using a console cable to connect a PC to the access point's console port.

At this point, your access point is fully installed. See the rest of this chapter if you need more detailed information on any of these installation steps.

## Installation Precautions:

Follow these precautions when installing your Access Point 530:

---

### Cautions

- Make sure that the power source circuits are properly grounded, then use the power adapter supplied with the access point to connect it to the power source.
  - You can alternatively power the access point through a network connection to a switch or other network connection device that provides Power over Ethernet. However, note that if the access point is connected to a power source using its AC power adapter, Power over Ethernet is disabled.
  - Use only the AC power adapter supplied with the access point. Use of other adapters, including adapters that came with other ProCurve Networking products, may result in damage to the equipment.
  - When using the access point's AC power adapter, note that the AC outlet should be near the access point and should be easily accessible in case the access point must be powered off.
  - Ensure that the access point does not overload the power circuits, wiring, and over-current protection. To determine the possibility of overloading the supply circuits, add together the ampere ratings of all devices installed on the same circuit as the access point and compare the total with the rating limit for the circuit. The maximum ampere ratings are usually printed on devices near the AC power connectors.
  - When using the AC power adapter, do not install the access point in an environment where the operating ambient temperature might exceed 40° C (104° F). When using PoE power, do not install the access point in an environment where the operating ambient temperature might exceed 50° C (122° F)
  - Make sure the air flow around the sides of the access point is not restricted.
-

## 1. Prepare the Installation Site

- **Cabling Infrastructure** - Ensure that the cabling infrastructure meets the necessary network specifications. See the following table for cable types and lengths, and see appendix B, “Access Point Port and Network Cables” for more information.

**Table 2-1. Summary of Cable Types to Use With the Access Point**

Port Type	Cable Type	Length Limits
<b>Twisted-Pair Cables</b>		
10/100Base-TX	<ul style="list-style-type: none"><li>• <b>10 Mbps operation:</b> Category 3, 4, or 5, 100-ohm unshielded twisted-pair (UTP)</li><li>• <b>100 Mbps operation:</b> Category 5, 100-ohm UTP cable.</li></ul>	100 meters  <b>Note:</b> Since the 10Base-T operation is through the 10/100Base-TX port on the access point, if you ever want to upgrade the ports on other devices to 100Base-TX, it would be best to cable the 10/100Base-TX port on the access point initially with category 5 cable. The 10/100-Base-TX port on the Access Point 530 uses the “HP Auto MDIX” feature, which means that you can use either straight-through or crossover twisted-pair cables to connect the access point to a switch or workstation.

- **Installation Location** - Before installing the access point, plan its location and orientation relative to other devices and equipment:
  - Try to place the access point in the center of your wireless network. Normally, the higher you place the antennas, the better the performance. You may need to reposition the access point after testing the signal strength on several wireless stations to ensure that the access point’s location provides optimal reception throughout the service area.
  - At the back of the access point, leave at least 7.6 cm (3 inches) of space for the twisted-pair cabling and the power cord.
  - On the sides of the access point, leave at least 7.6 cm (3 inches) for cooling.

## 2. Verify the Access Point Completes Initialization

Before mounting the access point in its network location, you should first verify that it is working properly by plugging it into a power source, or connecting it to a switch that provides Power over Ethernet, and verifying that it completes its system initialization.

1. Connect a network cable from a PoE source device (such as a switch) to the RJ-45 port on the back of the access point, or connect the supplied power adapter to the power connector on the back of the access point, and then into a properly grounded electrical outlet.

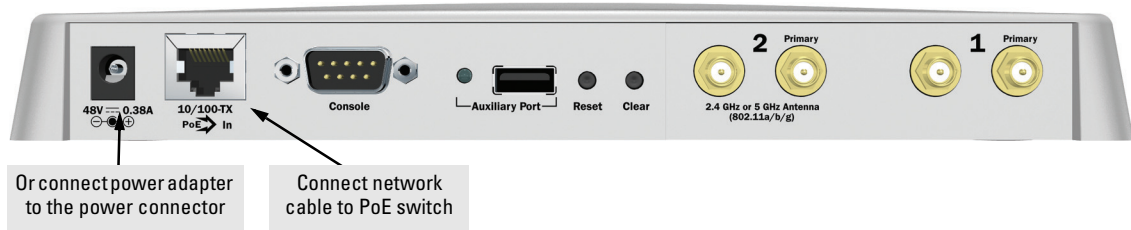

### Note

The Access Point 530 does not have a power switch. It is powered on when the power adapter is connected to the access point and to a power source, or when a network cable is connected to the access point and to a network device that provides Power over Ethernet. For safety, when connecting to an electrical outlet, the power outlet should be located near the access point.

Use only the AC power adapter supplied with the access point. Use of other adapters, including adapters that came with other ProCurve Networking products, may result in damage to the equipment.

2. Check the LEDs on the access point as described below.

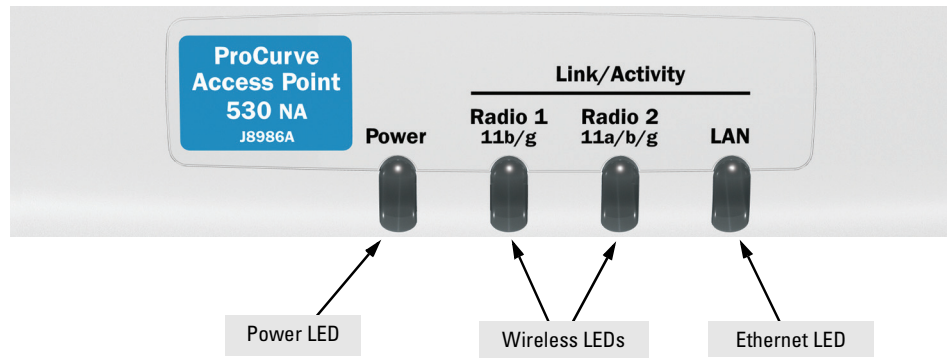

When the access point is powered on, it performs its system initialization. The system initialization takes between 30 seconds and one minute to complete.

### LED Behavior:

#### During the system initialization:

- The Power LED first turns on immediately, then the Power, LAN, Radio 1, and Radio 2 LEDs turn on and off several times during phases of the initialization.

#### When the system initialization completes successfully:

- The **Power** LED remains on green.
- The **LAN** and **Radio** LEDs on the top of the access point go into their normal operational mode:
  - If the RJ-45 network port and radio interfaces are connected to active network devices, the LEDs should be blinking at a rate proportional to the traffic rate. If there is no network activity, the LEDs should still be blinking at approximately 5 second intervals.
  - If the RJ-45 network port is not connected to an active network device and the radio interfaces are disabled, the LEDs should be off.

If the LED display is different than what is described above, the system initialization has not completed correctly. Refer to chapter 5, “Troubleshooting” for diagnostic help.

### 3. Mount the Access Point

After you have verified that the access point completes its system initialization, you are ready to mount the access point in a stable location. The Access Point 530 can be mounted in these ways:

- on a wall
- on a standard electric receptacle box
- on a suspended ceiling T-rail
- on a horizontal surface

#### Wall Mounting

You can mount the access point on a wall as shown in the illustrations on the next page.

---

#### Caution

---

The access point should be mounted only to a wall or wood surface that is at least 1/2-inch plywood or its equivalent.

1. Position the mounting bracket on the wall, and mark the two corner holes. The orientation shown in the following figure is the most secure position for mounting the access point. Look for the marking “THIS SIDE UP” on the bracket. Do not mount the access point with its ports and connectors pointing down.
2. To mount the access point on a plastered brick or concrete wall, first drill two holes 22 mm deep and 3.5 mm in diameter, and press the two included wall plugs firmly into the drilled holes until they are flush with the surface of the wall.
3. Position the mounting bracket over the drilled holes, then insert the two 5/8-inch number 12 wood screws in the corner holes and tighten down the screws.
4. There are four recess slots on the bottom of the access point that match up with four protrusions on the mounting bracket, as shown in the following figures.  
  
Slide the access point down onto the bracket so that the four protrusions on the bracket enter the four recess slots on the bottom of the access point. Push the access point firmly down onto the bracket until clicks into a locked position.
5. To prevent unauthorized removal of the access point, you can use a Kensington Slim MicroSaver security cable (not included) to attach the access point to an immovable object.

**Installing the Access Point 530**  
Installation Procedures

**Mounting the Bracket on a Wall**

Look for the "THIS SIDE UP" marking in this area

5/8-inch wood screws

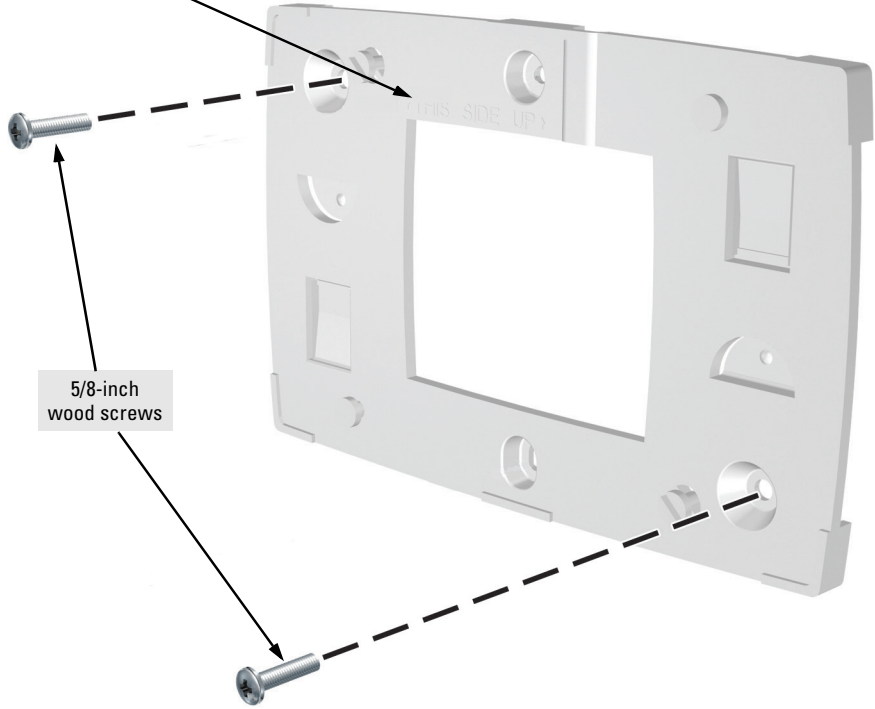

Installing the  
Access Point 530

### Sliding the Access Point onto the Bracket

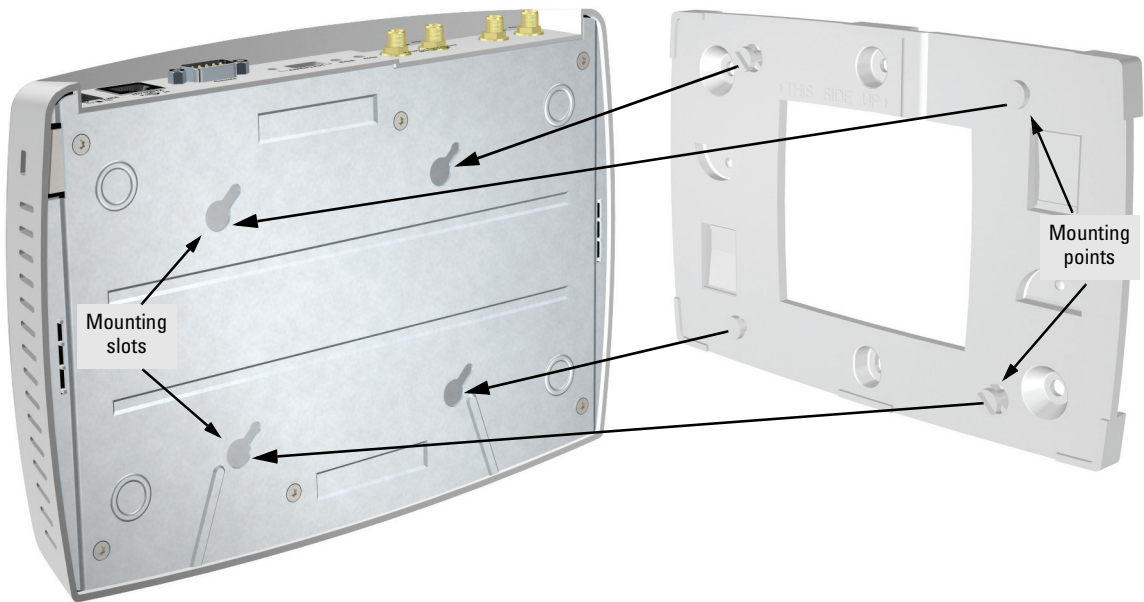

## Standard Electrical Box Mounting

You can mount the access point on a standard electric receptacle box as shown in the illustration on the next page.

1. Position the mounting bracket on the electrical box with the two center holes positioned over the screw holes on the box. The orientation shown in the following figure is the most secure position for mounting the access point. Look for the marking “THIS SIDE UP” on the bracket. Do not mount the access point with its ports and connectors pointing down.
2. Insert two 6-32 machine screws in the center holes and tighten down the screws.
3. There are four recess slots on the bottom of the access point that match up with four protrusions on the mounting bracket, as shown in the illustration for normal wall mounting.

Slide the access point down onto the bracket so that the four protrusions on the bracket enter the four recess slots on the bottom of the access point. Push the access point firmly down onto the bracket until clicks into a locked position.

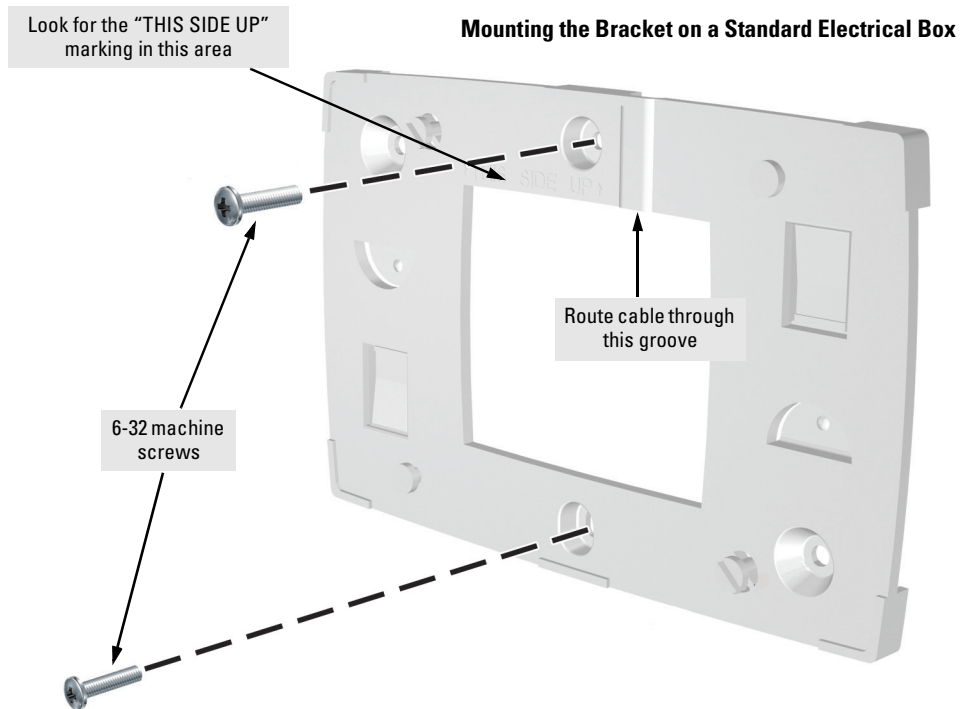

## Suspended Ceiling Mounting

You can mount the access point on a suspended ceiling T-rail as shown in the illustrations on the next page.

1. Attach the access point to its mounting bracket by sliding the unit down onto the bracket so that the four protrusions on the bracket enter the four recess slots on the bottom of the access point. Push the access point firmly down onto the bracket until clicks into a locked position.
2. Position the access point with its mounting bracket at a slight angle to the suspended ceiling T-rail.
3. Push the access point firmly onto the T-rail, then turn counterclockwise until the rail snaps into the clips on the access point's bracket.

### Mounting the Access Point on a Suspended Ceiling T-Rail

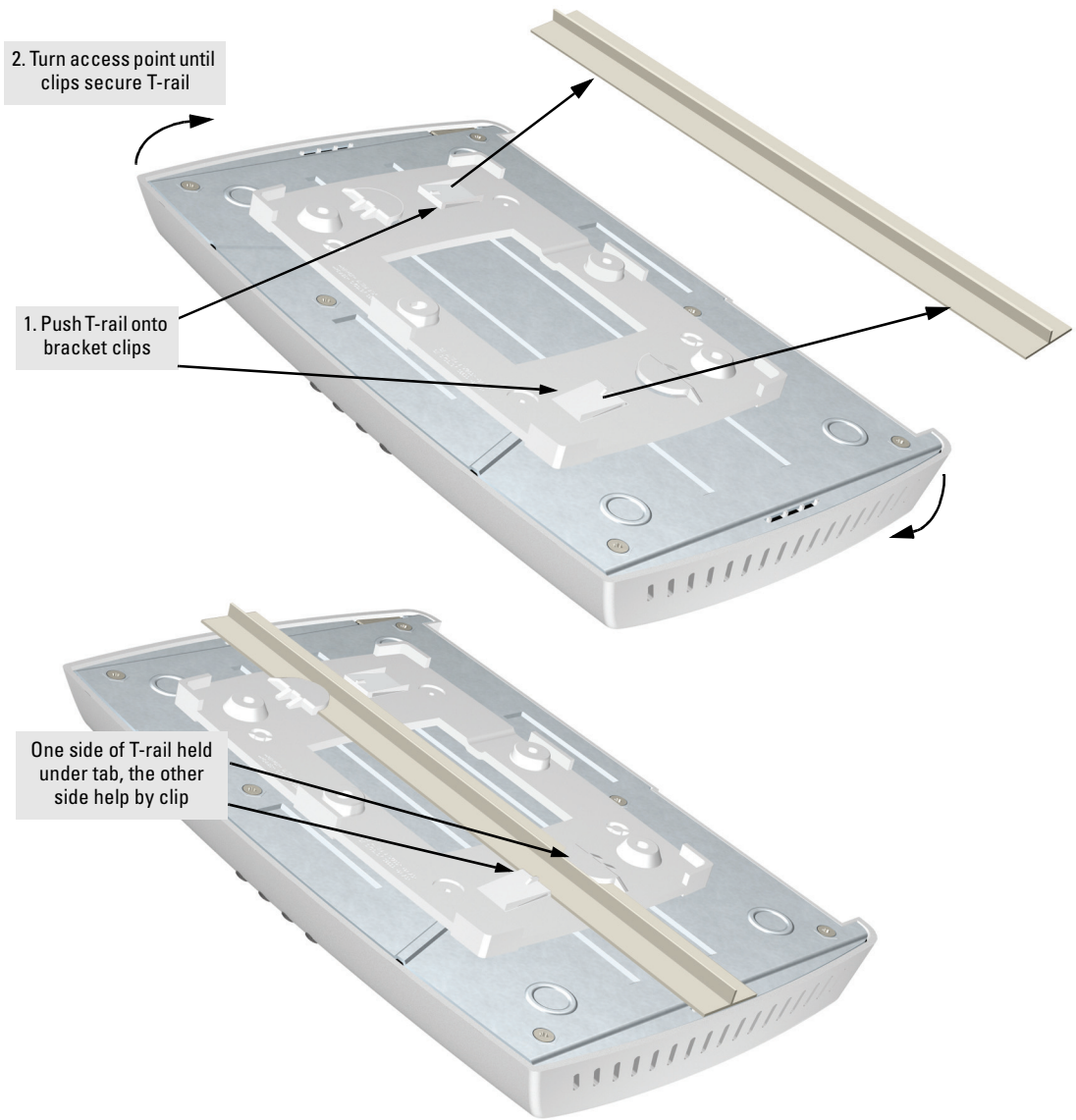

Installing the  
Access Point 530

## Horizontal Surface Mounting

Place the access point on a table or other horizontal surface. The access point accessory kit provides rubber feet that can be used to help keep the access point from sliding on the surface.

Attach the rubber feet to the four corners on the bottom of the access point within the embossed circles. Use a sturdy surface in an uncluttered area. You may want to secure the networking cable and access point's power cord to the table leg or other part of the surface structure to help prevent tripping over the cords.

---

### Caution

---

Make sure the air flow is not restricted around the sides of the access point.

## 4. Connect the Access Point to a Power Source

1. Plug the included power adapter into the access point's power connector and into a nearby AC power source.

Or, alternatively, connect the Ethernet port on the access point to a switch or other network device that provides Power over Ethernet.

2. Re-check the LEDs during the system initialization. See "LED Behavior" on page 2-6.

## 5. Connect the Network Cable

Connect the network cable, described under “Cabling Infrastructure” (page 2-4), from the network device or your patch panel to the RJ-45 port on the access point.

### Using the RJ-45 Connectors

#### To connect:

Push the RJ-45 plug into the RJ-45 port until the tab on the plug clicks into place. When power is on for the access point and for the connected device, the 10/100Base-TX link LED should light to confirm a powered-on device (for example, a switch) is at the other end of the cable.

If the 10/100Base-TX link LED does *not* go on when the network cable is connected to the port, see “Diagnosing with the LEDs” in chapter 5, “Troubleshooting”.

#### To disconnect:

Press the small tab on the plug and pull the plug out of the port.

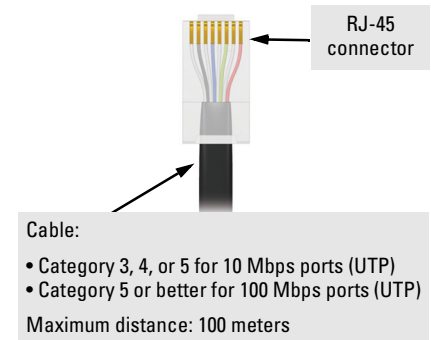
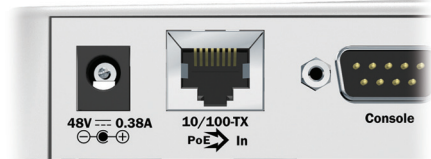

## 6. (Optional) Connect External Antennas to the Access Point

If you intend to use optional external antennas with the access point, connect them by following the instructions in chapter 4, “Using an External Antenna with the Access Point 530”.

## 7. (Optional) Connect a Console to the Access Point 530

The Access Point 530 has a full-featured, easy to use console interface for performing access point management tasks, including the following:

- modify the access point's configuration to optimize access point performance, enhance network traffic control, and improve network security
- download new software to the access point
- set a Manager password to control access to the access point from the console, Web browser interface, and network management stations

The console can be accessed through these methods:

- **Out-of-Band:** Use a serial cable for connecting a PC or VT-100 terminal to be used as a console directly to the access point.
- **In-Band:** Access the console using Telnet or Secure Shell (SSH) from a PC on the network, and a VT-100 terminal emulator. This method requires that you first configure the access point with an IP address and subnet mask by using either out-of-band console access or through DHCP. For more information on IP addressing and on starting a Telnet or SSH session, see chapter 3, "Getting Started With Access Point Configuration", and the *Management and Configuration Guide*, which is on the Documentation CD-ROM that came with your access point.

The Access Point 530 can simultaneously support one out-of-band console session through the Console Port and four in-band Telnet or SSH console sessions.

---

### Note

---

For information on using the Web browser interface to configure the access point, refer to the *Management and Configuration Guide*.

### Terminal Configuration

To connect a console to the access point, configure the PC terminal emulator as a DEC VT-100 (ANSI) terminal or use a VT-100 terminal, and configure either one to operate with these settings:

- 9600 baud
- 8 data bits, 1 stop bit, no parity, and flow control set to None
- For the Windows Terminal program, also disable (uncheck) the "Use Function, Arrow, and Ctrl Keys for Windows" option
- For the Hilgraeve HyperTerminal program, select the "Terminal keys" option for the "Function, arrow, and ctrl keys act as" parameter

You can only attach to the console using these configuration settings.

## Direct Console Access

To connect a console to the access point, follow these steps:

1. Connect the PC or terminal to the access point's Console port using a DB-9 female-to-female serial cable. (If your PC or terminal has a 25-pin serial connector, first attach a 9-pin to 25-pin straight-through adapter at one end of the console cable.)

The Console cable is described below. A null-modem cable or an HP serial cable, part number 5184-1894 (shipped with many ProCurve Networking switches), may be used.

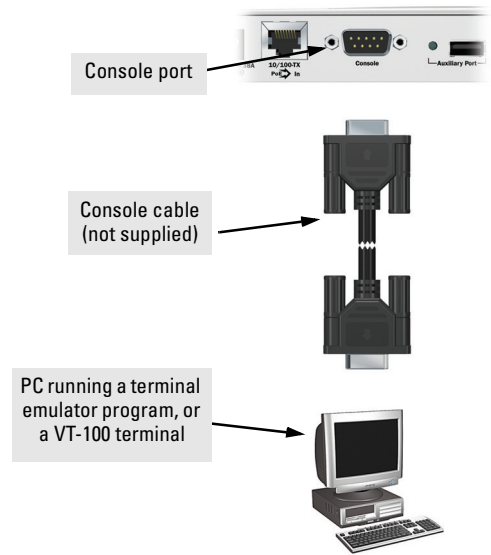

### Access Point 530 serial port pin and signalling details

Access Point 530 Pin Assignment	Pin Number	Access Point Signal (DTE)
<p>DB-9 male</p>	1	Reserved
	2	RXD (input)
	3	TXD (output)
	4	Reserved
	5	GND
	6	Reserved
	7	RTS (output)
	8	CTS (input)
	9	Reserved

Connection to PC serial ports also requires a crossover (null-modem) cable with a female DB-9 connector on both ends. Terminal connections will vary, requiring either a DB-9 or DB-25 connector, male or female. Serial cable options between an Access Point 530 and a PC terminal are shown in the following table.

**Note:** As indicated in the following table, some of the wires should not be connected. If you do connect the wires that are labeled “Reserved”, you might get unexpected results with some terminals.

**Serial interface signal directions**

DB-9 (DTE) Access Point 530		DB9 (DTE) Terminal or PC		DB-9 (DTE) Access Point 530		DB-25 (DTE) Terminal or PC	
1	Reserved	1		1	Reserved	8	
2		2		2		3	
3		3		3		2	
4	Reserved	4		4	Reserved	20	
5	GND	5		5	GND	7	
6	Reserved	6		6	Reserved	6	
7		7		7		4	
8		8		8		5	
9	Reserved	9		9	Reserved	22	

2. Turn on the terminal or PC’s power and, if using a PC, start the PC terminal program.
3. Enter **admin** at the **Username:** prompt, and **admin** at the **Password:** prompt. You will then see the access point console command (CLI) prompt, for example:

**ProCurve Access Point 530#**

If you want to continue with console management of the access point at this time, see chapter 3, “Getting Started With Access Point Configuration” for some basic configuration steps. For more detailed information, refer to the *Management and Configuration Guide*, which is on the Documentation CD-ROM that came with your access point.

## Sample Network Topologies

This section shows you a few sample network topologies in which the Access Point 530 is implemented. The access point is designed to be deployed in an integrated configuration with wired Ethernet LANs, providing network access to wireless stations in the wireless coverage area.

The access point's radios can be configured to operate in any of the following modes:

- infrastructure wireless LAN
- infrastructure wireless LAN with roaming
- Wireless Distribution System (WDS) bridge
- Wireless Distribution System (WDS) repeater

For more topology information, see the ProCurve Networking Web site at: <http://www.procurve.com>.

## Infrastructure Wireless LAN

The Access Point 530 is designed to provide access to a wired LAN for wireless stations. An integrated wired and wireless LAN is called an Infrastructure configuration. A Basic Service Set (BSS) consists of a group of wireless PC users and an access point that is directly connected to the wired LAN. Each wireless PC in a BSS can communicate with any computer in its wireless group, or access other computers or network resources in the wired LAN through the access point.

The infrastructure configuration extends the accessibility of wireless PCs to the wired LAN and can be used for access to central network resources, or for connections between mobile workers, as shown in the following figure.

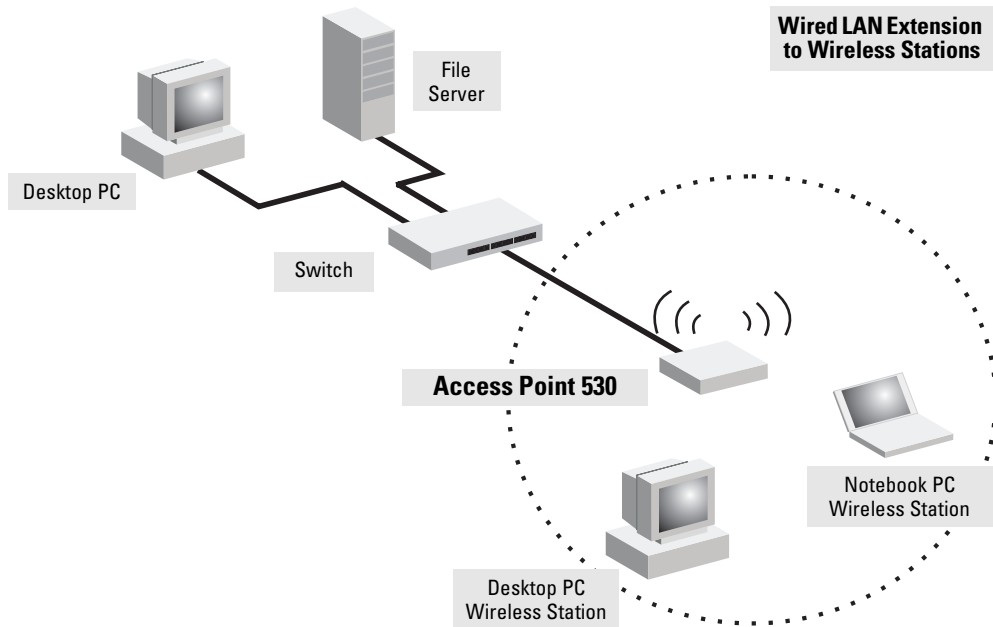

## Infrastructure Wireless LAN with Roaming

The Basic Service Set (BSS) defines the communications domain for each access point and its associated wireless stations. The BSS ID is a 48-bit binary number based on the access point's wireless MAC address, and is set automatically and transparently as stations associate with the access point. The BSS ID is used in frames sent between the access point and its stations to identify traffic in the service area.

The BSS ID is only set by the access point, never by its stations. The stations only need to set the Service Set Identifier (SSID) that identifies the wireless network provided by one or more access points. The SSID can be manually configured by the stations, can be detected in an access point's beacon, or can be obtained by querying for the identity of the nearest access point.

A wireless infrastructure can also support roaming for mobile workers. More than one access point can be configured to create an Extended Service Set (ESS). By placing the access points so that a continuous coverage area is created, wireless users within this ESS can roam freely. All ProCurve Networking wireless network cards, adapters, and access points within a specific ESS must be configured with the same SSID.

**Installing the Access Point 530**  
Sample Network Topologies

Installing the  
Access Point 530

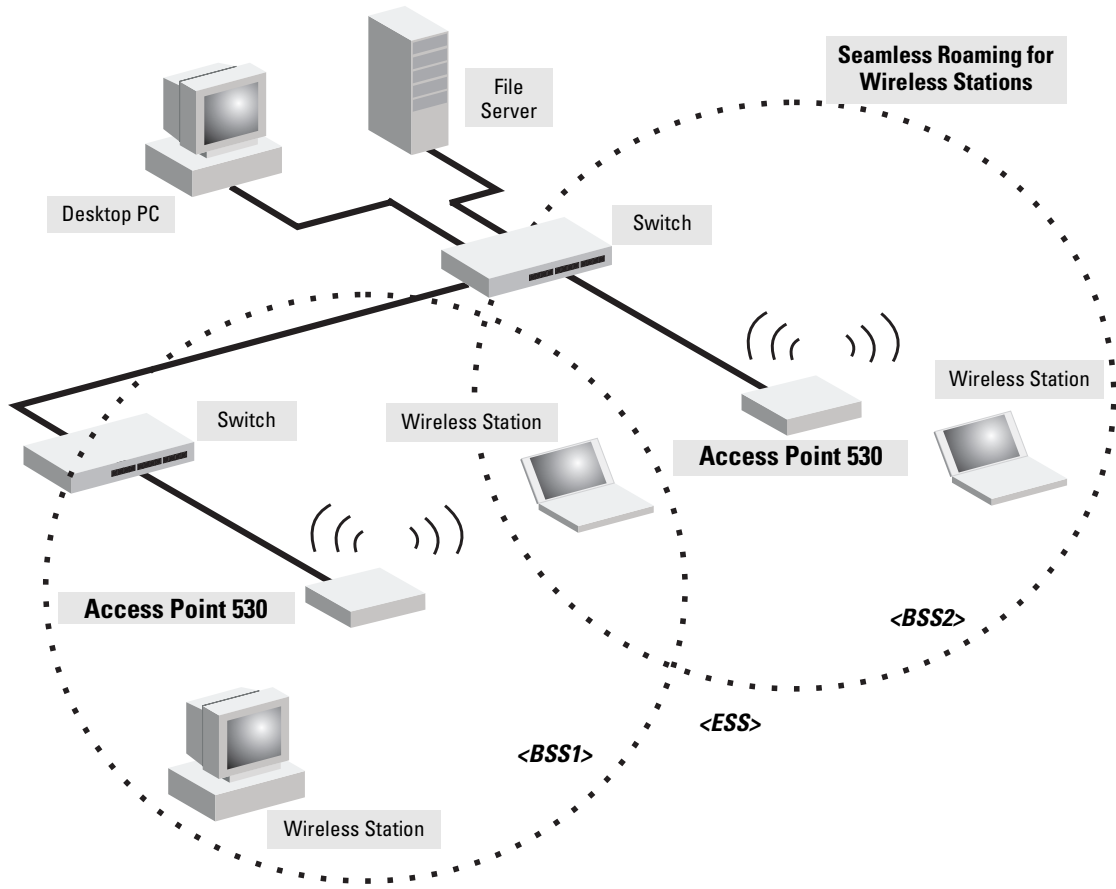

## Wireless Distribution System (WDS) Bridge

The IEEE 802.11 standard defines a Wireless Distribution System (WDS) for bridge connections between access points (BSS areas). The access point radios can be configured to use WDS to forward traffic over secure links between Access Point 530 units. This enables the access point to provide wireless bridge extensions to network segments that are remote or isolated, such as between buildings on separate sites.

Up to six WDS bridge links can be specified for an access point radio. One Access Point 530 must serve as the “root bridge” and be connected to the main core of the wired LAN. This “root bridge” access point can then provide WDS links for up to six other Access Point 530 units.

The access point supports WDS bridge links on either Radio 1 (802.11a/b/g) or Radio 2 (802.11b/g) and can be used with various external antennas to offer flexible deployment options. Although a radio can implement WDS links and support wireless stations, for performance reasons it is better to dedicate one radio for WDS bridge links and use the other radio to service wireless stations, as shown in the following figure.

**Installing the Access Point 530**  
Sample Network Topologies

Installing the  
Access Point 530

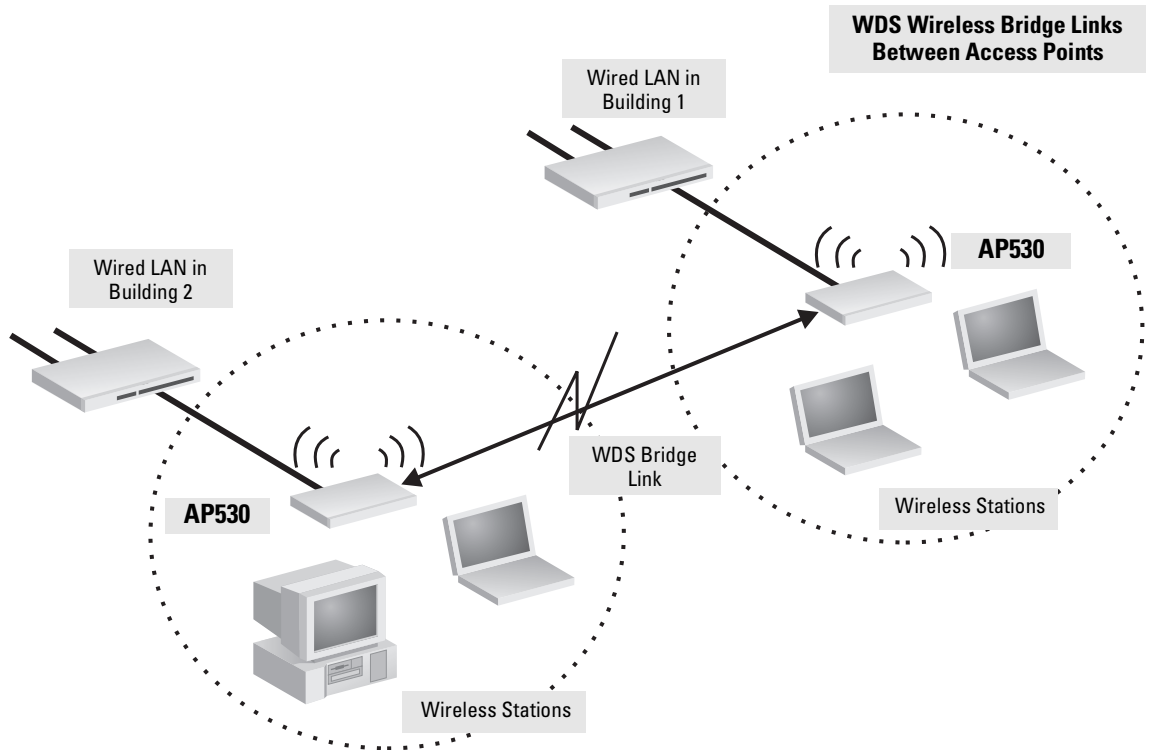

## Wireless Distribution System (WDS) Repeater

The Access Point 530 can also operate as a WDS bridge “repeater” to extend the range of links to other access points or wireless stations. The access point can support up to six WDS repeater links.

Operating as a wireless repeater, the access point may not have an Ethernet link to a wired LAN. When the access point operates as a wireless repeater only half the normal throughput is possible. This is because the access point has to receive and then re-transmit all data on the same radio channel.

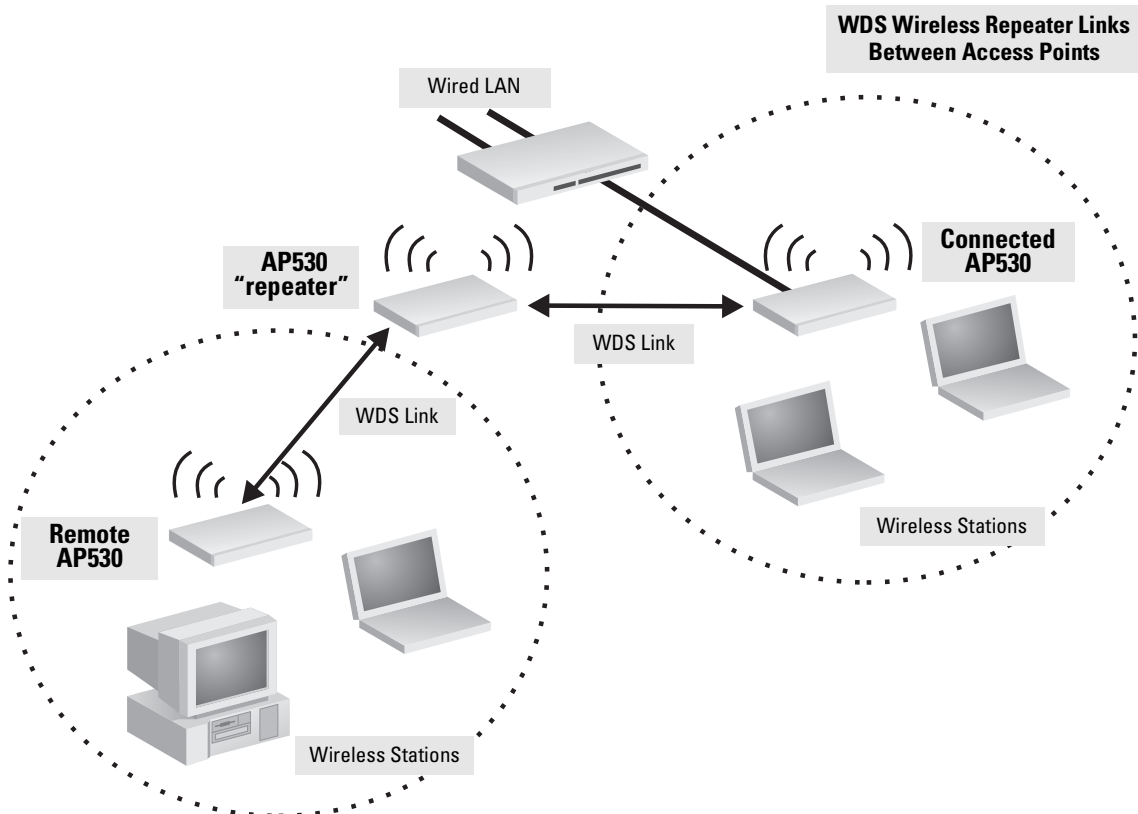

*— This page is intentionally unused. —*

# Getting Started With Access Point Configuration

---

This chapter is a guide for using the access point's console to quickly assign an Internet Protocol (IP) address and subnet mask to the access point, set a manager password, and, optionally, configure other basic features.

For more information on using the access point's console and the Web browser interface, please see the *Management and Configuration Guide*, which is on the Documentation CD-ROM that came with your access point.

## Recommended Minimal Configuration

In the factory default configuration, the access point is configured as a DHCP client. If the access point fails to obtain an IP address from the DHCP server, it uses its default static IP address of 192.168.1.10. If this address is not compatible with your network, then the access point can only be managed through a direct console connection. To manage the access point through in-band (networked) access, you should configure the access point with an IP address and subnet mask compatible with your network. Also, you should change the default Manager password that controls access to the console and Web browser interface. Other parameters can be left at their default settings or you can configure them with values you enter.

---

### Caution

A correct country code must be set for the country in which you operate the access point, so that it uses the correct authorized radio channels for wireless network devices. The country code for the ProCurve Wireless Access Point 530 NA (J8986A) is preset to "US" and can only be changed from "US" to the country codes for either Canada or Mexico.

The ProCurve Wireless Access Point 530 WW (J8987A) has no preset country code and must be configured before you can enable radio communications for the access point. Refer to "To Set the Access Point's Country Code" on page 3-4 for information on setting the country code.

Many other features can be configured through the access point's console interface to optimize the access point's performance, to enhance your control of the network traffic, and to improve network security. Once an IP address

has been configured on the access point, these features can be accessed more conveniently through a remote Telnet or Secure Shell (SSH) session, or through the access point's Web browser interface.

For more information on IP addressing, refer to "Configuring IP Settings" in the *Management and Configuration Guide*.

---

### Note

By default, the access point is configured to acquire an IP address configuration from a DHCP server. To use DHCP instead of the manual method described in this chapter, see "Configuring Ethernet Settings" in the *Management and Configuration Guide*, which is on the Documentation CD-ROM that came with your access point.

---

## Using the Command Line Interface

The quickest and easiest way to minimally configure the access point for management and password protection in your network is to use a direct console connection to the access point, start a console session, and access the command line interface (CLI).

### To Set the Manager User Name and Password

Management access to the access point's Web and CLI interface is controlled through a single user name and password. The Manager user name and password allows full read/write privileges for the Web and CLI.

1. Using the method described in the preceding chapter, connect a terminal device to the access point, and press **[Enter]** to initiate the console connection.
2. Type **admin** for the default Manager user name and also **admin** for the default password, then press **[Enter]**. The CLI prompt appears displaying the access point's model number.

```
ProCurve-AP-530 login: admin
Password:
ProCurve Access Point 530#
```

3. Type **configure** to enter global configuration mode.

```
ProCurve Access Point 530#configure
ProCurve Access Point 530(config)#
```

4. Type **password manager password** to create a password for the Manager, where *password* can consist of between 1 and 32 alphanumeric characters and is case sensitive.

```
ProCurve Access Point 530(config)#password manager 1AB2F
ProCurve Access Point 530(config)#
```

## To Set the Access Point's IP Address

By default, the access point is configured to automatically receive IP addressing from a Dynamic Host Configuration Protocol (DHCP) server. However, if you are not using a DHCP server to configure IP addressing, use the CLI to manually configure the IP values.

1. From the global configuration mode, type **interface ethernet** to access the Ethernet interface-configuration mode.

```
ProCurve Access Point 530(config)#interface ethernet
ProCurve Access Point 530(ethernet)#
```

2. Type **show ip** to display the access point's default IP configuration, including IP address, subnet mask, and default gateway. The following illustration shows the default settings.

```
ProCurve Access Point 530(ethernet)# show ip
IP Address Information:
System Host Name   ProCurve-AP-530
IP Address         192.168.1.10
Subnet Mask        255.255.255.0
Default Gateway    not set
DHCP Client        Enabled

DNS Information (Obtained from DHCP):
Domain Name Suffix not set
Primary DNS Server not set
Secondary DNS Server not set

ProCurve Access Point 530(ethernet)#
```

3. To manually assign an IP address, type **ip address ip-address netmask**, where *ip-address* is the access point's IP address and *netmask* is the network mask for the network. If managing the access point from another subnet, you must also set the default gateway with the **ip default-gateway gateway** command, where *gateway* is the address of the default gateway router. Check with your system administrator to obtain an IP address that is compatible with your network.

```
ProCurve Access Point 530(ethernet)#ip address 192.168.2.2 255.255.255.0
ProCurve Access Point 530(ethernet)#ip default-gateway 192.168.2.254
ProCurve Access Point 530(ethernet)#
```

## To Set the Access Point's Country Code

The ProCurve Wireless Access Point 530 NA (J8986A) is preset with a country code of "US," allowing the use of radio channels 1 - 11 for 802.11b/g operation and radio channels 36 - 64 and 149 - 161 for 802.11a operation, as supported under FCC regulations. The country code can be changed from "US" to only the country codes for either Canada or Mexico.

The ProCurve Wireless Access Point 530 WW (J8987A) does not have a preset country code. You must set the country code for the country in which you operate the access point. The country code can only be set using the CLI.

---

### Caution

The ProCurve Wireless Access Point 530 requires the user to select the appropriate Country Code during the initial set up. Once the country code has been set, the access point will automatically limit the available channels, ensuring compliant operation in the selected country. Incorrectly entering the country code may result in illegal operation and may cause harmful interference to other systems. The user is obligated to ensure that the radio is operating in accordance with channel, power, indoor/outdoor restrictions and license requirements for the intended country.

---

*Note that once you have set the country code, it can only be changed by restoring the factory default settings as described under "Restoring Custom and Factory Default Configurations" on page 5-8.*

Select the two-character code for your country (refer to the *Management and Configuration Guide* for a full list of codes), then enter the **country** command followed by your country code; for example, **gb** for Great Britain.

```
ProCurve Access Point 530#country gb
ProCurve Access Point 530#
```

## To Configure Radio Settings

The access point supports up to 16 Service Set Identifier (SSID) interfaces per physical radio interface. Most radio parameters apply globally to all configured SSID interfaces. For each SSID interface, different security settings, VLAN assignments, and other parameters can be applied.

Each SSID interface can be configured individually to enable or inhibit the broadcast of the SSID in the radio's beacon frames. SSID interfaces that are not configured to broadcast the SSID are "hidden," only being advertised in probe responses.

When access point configuration parameters are changed, wireless stations may be temporarily disconnected until the new configuration parameter is enabled. This includes any changes to a WLAN or radio parameter.

---

## Note

---

The radios are disabled if the Country Code is not set. Once the Country Code is set, the radios can be enabled.

1. From any command level, type the **show radio** command followed by the radio number to display the radio's configuration, including the radio mode, radio channel, and operation status. The following illustration shows the default settings.

```
ProCurve Access Point 530# show radio 1
Description      Radio 1 - 802.11g
Base MAC        00:14:C2:A5:3C:00      Status           Disabled
Mode            802.11g           Channel-Policy   Auto
Channel         1                WLANs Supported  16
Preamble       long              CTS Protection   Enabled
Slot-time      short            Beacon-Interval(K-us) 100
TX-Power(dBm)  0                Power Reduction(dB)  0
Antenna Mode   diversity        Antenna(s) In Use  internal
RTS-Threshold  2347            Fragment-Threshold  2346
WMM QoS        Enabled          Inactivity Timeout  1800
Max Stations   256

Rate-Limiting (Disabled)
Rate-Limit(packets/second)  50      Burst-Limit(packets/second)  75

AP-Detection (Disabled)
Periodic Scan Duration(ms)  30      Periodic Scan Interval(sec)  10
List Max Entries           255    List Expiration Time(sec)   3600

ProCurve Access Point 530#
```

2. Type **configure** to enter global configuration mode, and then type **radio 1** to access the wireless interface-configuration mode for radio 1.

```
ProCurve Access Point 530#configure
ProCurve Access Point 530(config)#radio 1
ProCurve Access Point 530(radio1)#
```

3. Set the channel through which the access point's radio 1 (802.11b/g) communicates with its wireless stations. The default setting is to statically set the operating channel number. Type **channel-policy static channel**, where *channel* can be from 1 to 14, depending on the wireless regulations specified by your country. Otherwise, type **channel-policy auto** to have the access point automatically select the least congested channel.

```
ProCurve Access Point 530(radio1)#channel-policy static 11
ProCurve Access Point 530(radio1)#
```

- To set the primary Service Set Identifier (SSID) for the access point. Type **wlan 1** to enter SSID interface configuration for the primary SSID interface. Then type **ssid identifier**, where *identifier* can consist of up to 32 alphanumeric characters and is case sensitive.

```
ProCurve Access Point 530(radiol)# wlan 1
ProCurve Access Point 530(radiol-wlan1)# ssid AP530
ProCurve Access Point 530(radiol-wlan1)#
```

- To enable radio 1 for the access point, type **exit** to return to the configuration mode for radio 1, then type **enable** to enable the radio.

```
ProCurve Access Point 530(radiol-wlan1)# exit
ProCurve Access Point 530(radiol)# enable
ProCurve Access Point 530(radiol)#
```

- To configure the access point's radio 2 interface, type **radio 2** and repeat steps 1 to 4. Note that when the radio 2 interface mode is set to 802.11a, the available channels are 36 to 165, depending on the country setting.
- To save all configuration settings from the running configuration file to the startup configuration file, type **write memory** from any command level.

```
ProCurve Access Point 530(radiol-wlan1)# write memory
ProCurve Access Point 530(radiol-wlan1)#
```

Here is some information on the basic IP address and wireless configuration parameters. For more information on these parameters, see the *Management and Configuration Guide*, which is on the Documentation CD-ROM that came with your access point:

Parameter	Default	
Username	admin	The name of the manager.
Password	admin	The password for the manager.
IP Address	192.168.1.10	IP address compatible with your network.
Subnet Mask	255.255.255.0	Subnet mask compatible with your network.
Default Gateway	<i>not set</i>	IP address of the next-hop gateway node for network traffic that needs to be able to reach off-subnet destinations.
Radio 1 Mode	802.11g	The operating mode for Radio 1.
Radio 2 Mode	802.11a	The operating mode for Radio 2.
SSID	Radio 1 - SSID 1 Radio 2 - SSID 2	The Service Set Identifier (SSID) for the access point interface, which is broadcast in the beacon frames.
Channel Policy	Auto	The radio channel through which an access point radio communicates with its wireless stations. When attempting to connect, most wireless stations automatically set their radio channel to the same channel used by the access point.
Wireless Operation	Enabled	Wireless operation is automatically enabled after you have set the country code.

**Note:** The IP address and subnet mask assigned for the access point must be compatible with the IP addressing used in your network. For more information on IP addressing, see the *Management and Configuration Guide*, which is on the Documentation CD-ROM that came with your access point.

## Where to Go From Here

The above procedure, using the CLI, configured your access point with a Manager password, IP address, and subnet mask. As a result, with the proper network connections, you can now manage the access point from a PC equipped with Telnet or a Secure Shell client, or a Web browser interface. The above procedure also configured the primary Service Set Identifier (SSID), the radio channel, and enabled wireless operation. Your wireless stations can now access the network by setting their SSID and radio channel to the same values used by the access point. Note that some wireless stations can be configured to scan all of the radio channels for an access point and the SSID.

Some basic information on managing your access point is included in the next section. For more information on the console and Web browser interfaces, and all the features that can be configured on the Access Point 530, please see the *Management and Configuration Guide*, which is on the Documentation CD-ROM that came with your access point.

**To Recover from a Lost Manager Password:** If you cannot start a console session because of a lost manager password, you can reset the password to the factory default by getting physical access to the access point and pressing and holding the Clear button for more than one second.

---

## Using the IP Address for Remote Access Point Management

With your Access Point 530, you can use the access point's IP address to manage the access point from any PC that is on the same subnet as the access point. You can use either a Telnet or Secure Shell (SSH) session, or a standard Web browser to manage the access point.

---

### Note

To provide more security for the access point, management interfaces that are not required can be disabled. This includes the Web, Telnet, and SSH, as well as the serial console port. You can also disable the ability to reset the access point using the Clear and Reset buttons. For more information, see the *Management and Configuration Guide*, which is on the Documentation CD-ROM that came with your access point.

---

### Starting a Telnet Session

To access the access point through a Telnet session, follow these steps:

1. Make sure the access point is configured with an IP address and that the access point is reachable from the PC that is running the Telnet session (for example, use a **ping** command to the access point's IP address).
2. Start the Telnet program on a PC that is on the same subnet as the access point and connect to the access point's IP address.

Example:

**telnet 192.168.1.19**

3. Enter the user name and password. (The default user name is **admin** and the default password is also **admin**. You will then see the access point's console command (CLI) prompt, for example:

```
ProCurve-AP-530 login: admin
Password:
ProCurve Access Point 530#
```

Enter **?** to see a list of commands that can be executed at the prompt. Entering any command followed by **?** displays a list of options that are available at that point in the command entry.

## Starting an SSH Session

To access the console through an SSH session, SSH v2.0 client software must be installed on the management station PC. Note that after boot up, the access point's SSH server needs about two minutes to generate host encryption keys. The SSH server is disabled while the keys are being generated.

---

### Note

---

The access point supports only SSH version 2.0.

To access the access point through an SSH session, follow these steps:

1. Make sure the access point is configured with an IP address and that the access point is reachable from the PC that is running the SSH session (for example, use a **ping** command to the access point's IP address).
2. Start the SSH client program on a PC that is on the same subnet as the access point and connect to the access point's IP address.

Example:

**ssh 192.168.1.19**

3. Enter the Manager user name and password. (The default Manager user name is **admin** and the default password is also **admin**. You will then see the access point's console command (CLI) prompt, for example:

```
ProCurve-AP-530 login: admin
Password:
ProCurve Access Point 530#
```

## Starting a Web Browser Session

Your Access Point 530 can be managed through a graphical interface that you can access from any PC or workstation on the same subnet as the access point. Open a compatible browser and type the access point's IP address as the URL. (See "Using the Command Line Interface" on page 3-2 for information on setting the IP address.) No additional software installation is required to make this interface available; it is included in the access point's onboard software.

The operating and Web systems support recommended to manage the access point through the browser interface are as follows:

- Microsoft Internet Explorer version 5.5 or 6.x (with up-to-date patch level for either major version) on Microsoft Windows XP or Microsoft Windows 2000
- Netscape Mozilla 1.7.x on Redhat Linux version 2.4
- Mozilla/5.0 (Windows; U; Windows NT 5.1; rv:1.7.3) Gecko/20041001 Firefox/0.10.1

The administration Web browser must have JavaScript enabled to support the interactive features of the administration interface. It must also support HTTP uploads to use the firmware upgrade feature.

A typical Web browser interface screen is shown in the next illustration.

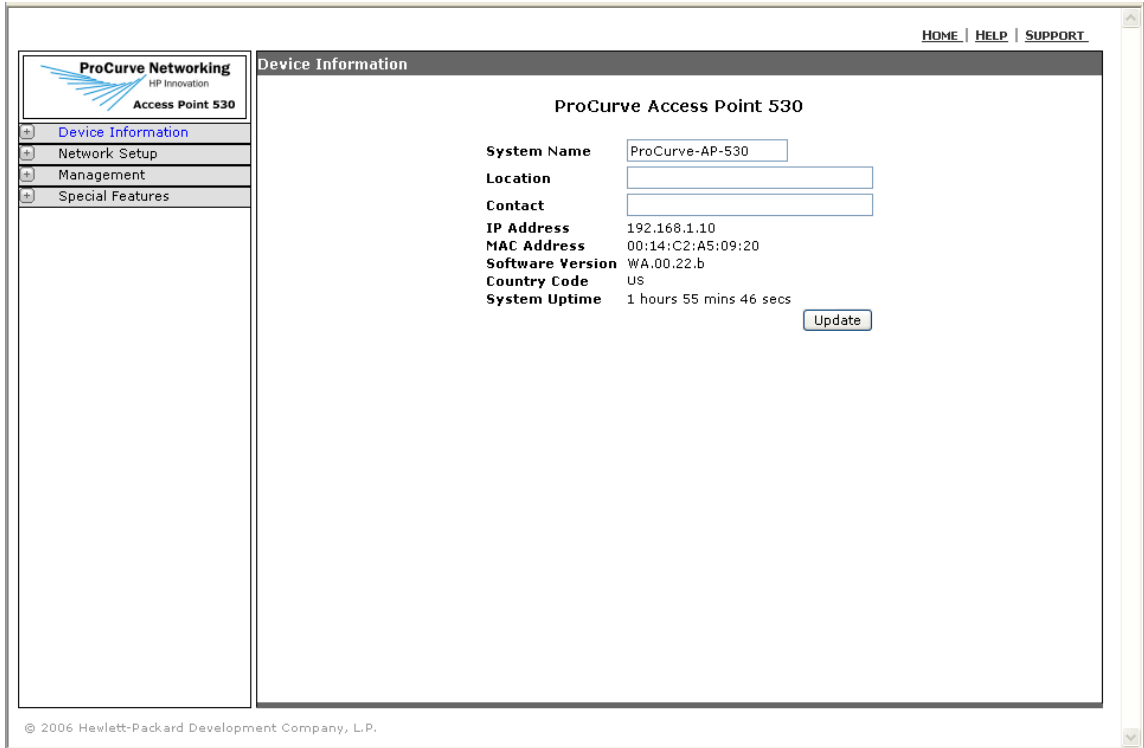

For more information on using the Web browser interface, please see the *Management and Configuration Guide*, which is on the Documentation CD-ROM that came with your access point.

A help system is also available for the Web browser interface. Click the **HELP** link in the upper-right corner of the screen.

— *This page is intentionally unused.* —

# Using an External Antenna with the Access Point 530

---

The Access Point 530 provides a variety of external antenna options for extending the radio range and shaping the coverage area. These antennas offer a number of different mounting locations, including indoor or outdoor, wall, ceiling, or radio mast.

This chapter shows you how to install an external antenna for your Access Point 530.

---

**Note**

---

When both Radio 1 and Radio 2 are configured to use 802.11b/g mode, then Radio 2 must be connected to an external antenna. Radio 2 can only operate using the internal antenna when configured for 802.11a mode.

---

**Professional  
Installation  
Required**

---

Only the ProCurve antennas listed in this guide are permitted to be connected to the Access Point 530. You must use the appropriate antennas, cables, and where applicable, surge arrestors, for your given region. You are responsible for verifying local regulations or legislation that may impose restrictions on the use of specific antenna and cable combinations. For this reason, you must consult with a professional installer who is trained in RF installation and knowledgeable in the local regulations prior to connecting an external antenna to your wireless radio product. It is the responsibility of the end user to ensure that the antenna installation complies with the local radio regulations. For more information on external antennas, see the ProCurve Networking Web site at: <http://www.procurve.com>.

---

## External Antenna Options

The Access Point 530 external antenna options are outlined in the following table:

**Table 4-1. Summary of External Antennas to Use With the Access Point 530**

Antenna Type	Part Number	Mounting	Horizontal Beamwidth (3dB)	Vertical Beamwidth (3dB)
2.4 GHz 5 dBi indoor/outdoor omnidirectional	J8441A	Ceiling or mast	360 Degrees	31 Degrees
2.4 GHz 8 dBi outdoor omnidirectional	J8444A	Mast	360 Degrees	12 Degrees
2.4 GHz 14 dBi indoor/outdoor Yagi (for point-to-point operation)	J8448B	Articulating wall or mast mount	34 Degrees	30 Degrees
2.4 / 5 GHz 3 dBi indoor omnidirectional diversity	J8997A	Ceiling grid	360 Degrees	70 Degrees
2.4 / 5 GHz 7 dBi indoor/outdoor directional	J8999A	Flush wall mount with integrated articulating feature	68 Degrees	66 Degrees
5 GHz 6 dBi indoor/outdoor omnidirectional	J8998A	Ceiling, mast or I-beam	360 Degrees	17 Degrees
5 GHz 14 dBi indoor/outdoor directional (for point-to-multipoint operation)	J9000A	Flush wall mount with integrated articulating feature	29 Degrees	27 Degrees

---

# Installation Procedures

Follow these steps to install an external antenna and connect it to the Access Point 530.

---

## Caution

Never mount the access point outdoors to be near an external antenna. The access point must always be installed indoors.

## 1. Plan the Installation

- **Pigtail Cables** - Use the coax pigtail cable attached to the antenna to connect to the access point. Because most pigtail cables are a relatively short length (83 cm or 33 inches), be sure to find a suitable mounting position for the antenna that is not too far from the access point. If an extension cable is required, please contact a professional installer who is trained in RF installation and knowledgeable in the local regulations.
- **Installation Location** - Plan the antenna's position and orientation.

---

## Warning

The radiated output power of this device is below the FCC radio exposure limits. Nevertheless, the device should be used in such a manner that the potential for human contact during normal operation is minimized. To avoid the possibility of exceeding the FCC radio frequency exposure limits, human proximity to the antennas should not be less than 25 cm (10 inches) during normal operation.

Consider these points:

- Use the antenna's mounting bracket or other hardware, if included.
- For optimum performance, mount antennas as high as possible above any obstructions, and away from any signal absorbing or reflecting structures (such as those containing metal)
- Be sure there are no other radio antennas mounted within 2 m (6 ft).
- Consider the antenna's radio coverage pattern so that it can properly cover the intended service area.
- **Omnidirectional Antennas** - Consider these factors when selecting a location for these antennas:
  - Always mount the antenna in a vertical orientation so that the radio coverage pattern fills the intended horizontal space.

- For optimum coverage, mount the antenna at the center of the area with a line-of-sight path to all points within the area.
- Avoid mounting next to or near building support columns or other obstructions that may cause reduced signal or null zones in parts of the coverage area.
- When mounting outdoors using a mast, make sure that the antenna extends beyond the top of the mast.
- **Directional Antennas** - Consider these factors when selecting a location for these antennas:
  - For optimum coverage, mount the antenna above any obstructions, directed at the center of the coverage area sector.
  - High-gain directional antennas provide a flattened radio coverage pattern in the horizontal plane. Use the tilting or articulated mounts to point the antennas towards the coverage area.
- **Outdoor Installation** - When installing an antenna outdoors, be sure to consider these additional factors:
  - Always place the antenna away from power and telephone lines
  - Make sure that the antenna, any supporting structure, and cables are all properly grounded.
  - For lightning protection, consider using a lightning arrestor immediately before the cable enters the building.

---

**Warning**

---

Never install an antenna or construct a radio mast near overhead power lines.

## 2. Mount the Antenna

Install the antenna in its planned location using the brackets, clips, or other hardware included in the antenna package.

Refer to documentation included with the antenna for specific information and installation instructions.

## 3. Connect Pigtail Cables to the Access Point

Use the pigtail cables that are attached to the antenna, or are included in the antenna package. If an extension cable is required, please contact a professional installer who is trained in RF installation and knowledgeable in the local regulations.

Note that diversity antennas have two pigtail cables. A diversity antenna includes two internal antenna elements that are identical. Both antenna pigtail cables must be connected to the access point for correct operation.

Other non-diversity antennas, which have only one pigtail cable, attach to the access point's "Primary" antenna connector for the appropriate radio.

To connect pigtail cables to the access point, follow these steps:

1. Disable the access point radio using the Web browser interface, CLI, or SNMP.
2. Remove power to the access point.
3. Remove the connector cover on the back of the access point.
4. For diversity antennas, connect the antenna pigtail cables to the exposed Reverse SMA connectors for the appropriate radio.

For non-diversity antennas, be sure to connect the single pigtail cable to the Reverse SMA connector labeled "Primary."

---

**Caution**

---

Do not over-torque the antenna cables on SMA connector. (8 in-lb max).

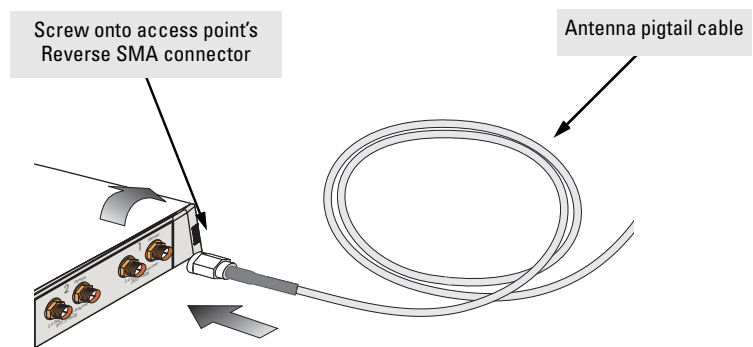

5. Reconnect power to the access point.

---

**Note**

---

Before enabling the radio with an external antenna attached, be sure to first configure the access point's antenna mode and type.

## 4. Configure the Antenna Mode and Type

Using the Web browser interface, CLI, or SNMP, you must configure the Access Point 530 to use an external antenna. For more information on access point configuration, see the *Management and Configuration Guide*, which is on the Documentation CD-ROM that came with your access point.

The access point must be set for the type of external antenna that is attached, either a diversity antenna that connects to two access point antenna connectors, or non-diversity antenna that has a single pigtail connection.

### Setting the Antenna Mode and Type Using the CLI

1. Type **configure** to enter global configuration mode.

```
ProCurve Access Point 530#configure
ProCurve Access Point 530(config)#
```

2. Type **radio 1** to enter interface configuration mode for radio 1.

```
ProCurve Access Point 530(config)#radio 1
ProCurve Access Point 530(radio1)#
```

3. Type **antenna mode diversity** if using a diversity antenna.

```
ProCurve Access Point 530(radio1)#antenna mode diversity
```

Type **antenna mode single** if using a non-diversity antenna.

```
ProCurve Access Point 530(radio1)#antenna mode single
```

4. Type **antenna external** to set the access point to use an antenna attached to the radio's external antenna connectors.

```
ProCurve Access Point 530(radio1)#antenna external
```

### Setting the Antenna Mode and Type Using the Web Interface

1. Select **Network Setup** > **Radio** tab > **[Edit]** button > **Advanced Settings** Window.
2. To set the radio to use an internal or external antenna, select **Internal** or **External**, using the **Antenna Type** drop-down.
3. To set the radio to use a specific antenna mode, select **Diversity** or **Single**, using the **Antenna Mode** drop-down.
4. Click **[Update]** to set the antenna parameters.

**Radio 1 - Advanced Settings**

**Broadcast/Multicast Rate Limiting**

Rate Limit  (packets per second)  
Rate Limit Burst  (packets per second)

---

**Antenna Type**  **Protected Mode**

**Antenna Mode**  **Preamble**

**RTS Threshold**  (0 - 2347) **Slot Time**

**Fragmentation Threshold**  (256 - 2346, Even Numbers)

**Inactivity Timeout**  (300 - 86400 s)

**Beacon Interval**  (20 - 2000 K-us)

---

Antenna Type selection;  
Internal or External.

Antenna Mode selection;  
Diversity or Single.

— *This page is intentionally unused.* —

# Troubleshooting

---

This chapter describes how to troubleshoot your ProCurve Wireless Access Point 530. Note that this document describes troubleshooting mostly from a hardware perspective. You can perform more in-depth troubleshooting on the Access Point 530 using the software tools available with the access point, including the full-featured console interface and the built-in Web browser interface.

This chapter describes the following:

- basic troubleshooting tips (page 5-1)
  - diagnosing with the LEDs (page 5-3)
  - proactive networking tools (page 5-5)
  - hardware diagnostic tests (page 5-6)
  - restoring customer and factory default configurations (page 5-8)
  - downloading new software to the Access Point 530 (page 5-10)
  - HP Customer Support Services (page 5-10)
- 

## Basic Troubleshooting Tips

Most problems are caused by the following situations. Check for these items first when starting your troubleshooting:

- **Connecting to devices that have a fixed full-duplex configuration.** By default, the RJ-45 port uses auto-negotiation to determine the duplex mode. That is, when connecting to attached devices, the access point will operate in one of two ways to determine the link speed and the communication mode (half duplex or full duplex):
    - If the connected device is also configured to use auto-negotiation, the access point will automatically negotiate both link speed and communication mode.
    - If the connected device has a fixed configuration, for example 100 Mbps, at half or full duplex, the access point will automatically sense the link speed, but will default to a communication mode of *half* duplex.
-

Because the Access Point 530 behaves in this way (*in compliance with the IEEE 802.3-2005 standard*), if a device connected to the access point has a fixed configuration at *full duplex*, the device will not connect correctly to the access point. The result will be high error rates and very inefficient communications between the access point and the device.

All devices connected to the Access Point 530 should be configured to auto-negotiate. To correct this problem you have to manually set the access point's RJ-45 port to match the duplex mode used by the attached device.

- **Faulty or loose cables.** Look for loose or obviously faulty connections. If the cables appear to be OK, make sure the connections are secure. If that does not correct the problem, try a different cable.
- **Non-standard cables.** Non-standard and miswired cables may cause network collisions and other network problems, and can seriously impair network performance. Use a new correctly-wired cable or compare your cable to the cable in appendix B, "Access Point Port and Network Cables" for pinouts and correct cable wiring. A category 5 cable tester is a recommended tool for every 100Base-TX network installation.
- **Improper Network Topologies.** It is important to make sure you have a valid network topology. Common topology faults include excessive cable length and excessive repeater delays between end nodes. If you have network problems after recent changes to the network, change back to the previous topology. If you no longer experience the problems, the new topology is probably at fault. Sample topologies are shown at the end of chapter 2 in this book, and some topology configuration guidelines can be found online at the ProCurve Networking Web site, <http://www.hp.com/rnd/index.htm>. under "network configuration examples."
- **Mobile users cannot connect to the network.** Make sure that the access point and wireless stations are configured with compatible security settings. Check to ensure that the wireless station is within the maximum range supported by the access point. Also verify that the wireless station has been configured with an IP address compatible with the attached network, either manually or via DHCP.

For more information on possible network problems and their solutions, refer to the technical note "Troubleshooting LAN Performance and Intermittent Connectivity Problems", which can be found on the ProCurve Networking Web site, <http://www.hp.com/go/hpprocurve>, in the Reference Library section under <http://www.hp.com/rnd/library/index.htm> under "T" in the "A-Z index."

## Diagnosing with the LEDs

Table 5-1 shows LED patterns on the access point that indicate problem conditions.

1. Check in the table for the LED pattern that you see on your access point.
2. Refer to the corresponding diagnostic tip on the next few pages.

**Table 5-1. LED Error Indicators**

LED Pattern Indicating Problems			Diagnostic Tips
Power LED	Radio LEDs	LAN LED	
Off with power cord plugged in	*	*	1
Off without power cord plugged in, but linked to a PoE source	*	*	2
Prolonged on or off during initialization <sup>†</sup>	Prolonged on or off during initialization <sup>†</sup>	Prolonged on or off during initialization <sup>†</sup>	3
On	Off	*	4
On	*	Off with cable connected	5
On	*	On, but the port is not communicating	6

\* This LED is not important for the diagnosis.  
<sup>†</sup> Initialization takes between 30 seconds and one minute after a power on or reset.

### Diagnostic Tips:

Tip	Problem	Solution
1	The access point is not plugged into an active AC power source, or the access point's AC power adapter may have failed.	<ol style="list-style-type: none"> <li>1. Verify that the power cord is plugged into an active power source and to the access point's AC power adapter. Make sure these connections are secure.</li> <li>2. Try power-cycling the access point by unplugging and plugging the power cord back in.</li> <li>3. If the Power LED is still not on, verify that the AC power source works by plugging another device into the outlet. Or try plugging the access point into a different outlet or try a different power cord.</li> </ol> <p>If the power source and power cord are OK and this condition persists, the access point's AC power adapter may have failed. Call your HP-authorized network reseller, or use the electronic support services from HP to get assistance. See the Customer Support/Warranty booklet for more information.</p>

Tip	Problem	Solution
2	The access point is not receiving power from the PoE source.	<ol style="list-style-type: none"> <li>1. Verify that access point's 10/100Base-TX port is attached to a PoE source device.</li> <li>2. Verify that the PoE source device is powered on, and that the PoE function has been administratively enabled on the source port attached to the access point.</li> <li>3. Refer to Tip 6 to verify that the network cable is functioning properly.</li> </ol>
3	The access point has experienced a software failure during initialization.	<p>After a power on or reset, the LEDs indicate stages of the system initialization. If there is a software failure during initialization, the LED pattern indicates at which stage the failure occurred. The normal LED sequence during initialization is as follows:</p> <p>Stage 1. Power LED on for 5 seconds. System initialization has started.</p> <p>Stage 2. LAN LED blinks 5 times in 1 second. The boot ROM has successfully initialized.</p> <p>Stage 3. All LEDs on for 5 seconds. The operating system kernel has successfully loaded.</p> <p>Stage 4. LAN LED on only. The operating system is mounting the file system.</p> <p>Stage 5. LAN and 11a/b/g LEDs on. Radio drivers have been successfully loaded.</p> <p>Stage 6. LAN, 11a/b/g, and 11b/g LEDs on. The access point software is initializing.</p> <p>Stage 7. Normal LED operation. Initialization has completed successfully.</p> <p>The entire initialization sequence takes between 30 seconds (normal reset) and one minute (factory default reset). If one of the above LED patterns display longer than one minute, a failure has occurred. Do the following:</p> <ol style="list-style-type: none"> <li>1. Reset the access point by pressing the Reset button on the back of the access point, or by power cycling the access point.</li> <li>2. If the fault indication reoccurs, attach a console to the access point (as indicated in chapter 2). Then, reset the access point. Messages should appear on the console screen identifying the error condition. Take note of the LED pattern and contact your HP-authorized network reseller, or use the electronic support services from HP to get assistance. See the Customer Support/Warranty booklet for more information.</li> </ol>
4	Wireless link has been administratively disabled.	Verify that the wireless port has not been disabled through an access point configuration change. You can use the console interface, or, if you have configured an IP address on the access point, use the Web browser interface to determine the state of the wireless port and re-enable the port if necessary. Also verify that the country code has been set.
5	The 10/100Base-TX network connection is not working properly.	<p>Try the following procedures:</p> <ul style="list-style-type: none"> <li>• Verify that both ends of the cabling, at the access point and the connected device, are connected properly.</li> <li>• Verify the connected device and access point are both powered <i>on</i> and operating correctly.</li> <li>• Verify duplex operation (see page 5-1).</li> <li>• If these procedures don't resolve the problem, try using a different cable.</li> </ul>
6	The port may be improperly configured.	<p>VLAN configuration may affect the port operation. Use the access point's console to see how the port is configured for VLANs.</p> <p>Make sure also, that the device at the other end of the connection is indicating a good link to the access point. If it is not, the problem may be with the cabling between the devices or the connectors on the cable.</p>

---

## Proactive Networking

The following interfaces provide tests, indicators, and an event log that can be used to monitor the access point and its network connections and to help you troubleshoot:

- A graphical Web browser interface that you can use to manage your access point from a PC running a supported Web browser, for example Microsoft Internet Explorer.

The Device Information tab can be used to display access point configuration settings, attached wireless station settings, and the event log.

- A full-featured easy-to-use console interface that you can access by connecting a standard terminal or PC running a terminal emulator to the access point's console port. (For information on the console port's pin assignments, see "Direct Console Access" on page 2-15.) The console interface is also accessible through a Telnet or Secure Shell connection. The **ping** command can test device access and connectivity. The **show** command at all levels of the CLI provides detailed access point configuration information.

---

## Hardware Diagnostic Tests

### Testing the Access Point by Resetting It

If you believe that the access point is not operating correctly, you can reset the access point. To reset the access point, either

- Unplug and plug in the power cord (power-cycling).
- Press the Reset button on the back of the access point for about two seconds (until the LEDs start to blink rapidly). If you are attached to the console port, you will see that the access point starts its system initialization.

---

#### Caution

If you press the Reset button with the Clear button in a specific pattern, you reset the board and reload the factory default settings. See “Restoring Custom and Factory Default Configurations” on page 5-8.

Power-cycling the access point and pressing the Reset button both cause the access point to perform its system initialization, which normally resolves any temporary operational problems. These reset processes also cause any network traffic counters to be reset to zero, and cause the System Up Time timer to reset to zero. Also, event log messages are erased, and the IP address may be changed if you are using DHCP.

### Checking the Access Point's LEDs

The system initialization is successful when the Power LED is on and the other LEDs are in a normal operating state after approximately one minute. If the LED pattern is different that this for longer than one minute, there may be a problem with the access point.

See “Diagnosing with the LEDs” on page 5-3 for information on interpreting the LED patterns.

### Checking Event Messages

Useful diagnostic messages may be displayed on the console screen when the access point is reset. As described in chapter 2 under step 7, “Connect a console to the access point,” connect a PC running a VT-100 terminal emulator program or a standard VT-100 terminal to the access point's Console Port and configure it with the terminal communication settings shown on page 2-14.

Then, when you reset the access point, note the messages that are displayed. Additionally, you can check the access point's event log, which can be accessed from the Web browser or a Syslog server.

## Testing Twisted-Pair Cabling

Network cables that fail to provide a link or provide an unreliable link between the access point and the connected network device may not be compatible with the IEEE 802.3 Type 10Base-T, or 100Base-TX standards. The twisted-pair cables attached to the Access Point 530 must be compatible with the appropriate standards. To verify that your cable is compatible with these standards, use a qualified cable test device.

## Testing Access Point-to-Device Network Communications

You can perform the following communication tests to verify that the network is operating correctly between the access point and any connected device that can respond correctly to the communication test.

- Ping Test – a network layer test used on IP networks that sends test packets to any device identified by its IP address

These tests can be performed through the access point's console interface from a terminal connected to the access point or through a Telnet or Secure Shell connection. For more information, see the *Management and Configuration Guide*, which is on the Documentation CD-ROM that came with your access point.

## Testing End-to-End Network Communications

Both the access point and the cabling can be tested by running an end-to-end communications test – a test that sends known data from one network device to another through the access point. You can run a Ping test to verify that the entire communication path between the two network devices is functioning correctly.

---

## Restoring Custom and Factory Default Configurations

As part of your troubleshooting process on the Access Point 530, it may become necessary to return the access point's configuration to custom or factory default settings. This process momentarily interrupts the access point's operation, clears the console event log, resets the network counters to zero, and reboots the access point. If restoring a custom default configuration, some basic settings, such as a Manager password and IP address, may be retained. When restoring the factory default configuration, all settings are cleared, including the Manager password and any IP address.

---

### Note

Restoring factory defaults removes all access point configuration changes that you have made from the factory default settings. This includes, for example, IP addresses, and radio interface settings. Returning the configuration of these features to their factory default settings may result in network connectivity issues.

If the access point has a valid configuration, and you are restoring the factory default settings for a reason other than configuration problems, you should save the access point configuration prior to performing the factory default reset. Then, after the reset and resolution of the original problem, you can restore the saved configuration to the access point. For both the save and restore processes, you can use the console **copy** command. For more information on this command, see the *Management and Configuration Guide*, which is on the Documentation CD-ROM that came with your access point.

You can restore a custom or factory default configuration either from the access point itself, or through the access point console.

---

### Note

The system, password, custom default, and factory default reset functions can be disabled by the access point's software. For more information, see the *Management and Configuration Guide*, which is on the Documentation CD-ROM that came with your access point.

To reset the access point configuration back to custom defaults, perform these steps:

1. Press the reset and clear buttons simultaneously.

2. Once the LEDs shut off, release the reset button. The LEDs flash rapidly about once per second.
3. While the LEDs are still flashing, release the clear button. The configuration sets to the custom default settings and the AP is rebooted.

To restore a custom default configuration using the console, execute the **erase startup-config** command from the console command prompt.

To execute the factory default reset on the access point, perform these steps:

1. Press the reset and clear buttons simultaneously.
2. Once the LEDs shut off, release the reset button. The LEDs will then flash about once per second.
3. Press the reset button (while continuing to hold the clear button). After about one second, all LEDs will flash rapidly (about 10 times per second).
4. *After the LEDs begin to flash rapidly*, release the clear button. The AP resets to factory defaults and reboots. You can then release the reset button.

To restore the factory default configuration using the console, execute the **copy factory-default startup-config** command from the console command prompt.

---

## Downloading New Access Point Software

When product enhancements occur for the Access Point 530, new software can be downloaded to the access point by several methods. For more information, see the *Management and Configuration Guide*, which is on the Documentation CD-ROM that came with your access point.

The new access point software is made available on the ProCurve Networking Web site, <http://www.hp.com/go/hpprocurve> under “product support – software upgrades.”

---

## HP Customer Support Services

If you are still having trouble with your access point, Hewlett-Packard offers support 24 hours a day, seven days a week through the use of a number of automated electronic services. See the Customer Support/Warranty booklet that came with your access point for information on how to use these services to get technical support. The ProCurve Networking Web site, <http://www.hp.com/go/hpprocurve> also provides up-to-date support information under “product support.”

Additionally, your HP-authorized network reseller can provide you with assistance, both with services that they offer and with services offered by HP.

### Before Calling Support

To make the support process most efficient, before calling your networking dealer or HP Support, you first should retrieve the following information:

Information Item	Information Location
<ul style="list-style-type: none"><li>product identification</li></ul>	the front of the access point, Access Point 530 (J8986A or J8987A)
<ul style="list-style-type: none"><li>details about the access point's status including the software (OS) version, a copy of the access point configuration, a copy of the access point Event Log, and a copy of the access point status and counters information</li></ul>	<ul style="list-style-type: none"><li>access point console (Global Configuration Level): <b>show</b> command</li><li>access point Web interface: Event Log</li><li>Syslog server entry file, if configured</li></ul>

<b>Information Item</b>	<b>Information Location</b>
<ul style="list-style-type: none"><li>• copy of your network topology map, including network addresses assigned to the relevant devices</li></ul>	your network records

— *This page is intentionally unused.* —

# Specifications

---

## Physical

<b>Width:</b>	24.9 cm (9.8 in.)
<b>Depth:</b>	17.3 cm (6.8 in.)
<b>Height:</b>	2.3 cm (0.9 in.)
<b>Weight:</b>	0.73 kg (1.6 lb)

## Electrical

### Adapter

<b>AC voltage:</b>	100-240 volts, 0.4A, 50/60 Hz
<b>DC voltage:</b>	48 volts, 0.26A (max)
<b>Power consumption:</b>	12.5 watts (max)

**Note:** Power can also be provided to the access point through the Ethernet port based on IEEE 802.3af Power over Ethernet (PoE) specifications. The access point is a Class 3 device, that is, the maximum power required is in the range of 6.49 to 12.95 watts. When both PoE is provided and the adapter is plugged in, PoE is turned off.

## Environmental

	Operating	Non-Operating
<b>Temperature:</b>	0° C to 50° C (32° F to 122° F) PoE mode 0° C to 40° C (32° F to 104° F) w/adapter	-40° C to 70° C (-40° F to 158° F)
<b>Relative humidity: (non-condensing)</b>	5% to 95%	5% to 95%
<b>Maximum altitude:</b>	3.05 Km (10,000 ft)	4.6 Km (15,000 ft)

## Connectors

- The 10/100 Mbps RJ-45 twisted-pair port is compatible with the IEEE 802.3u 100Base-TX and IEEE 802.3 Type 10Base-T standards.

**Note:** To provide Power over Ethernet to the access point, all 4 pairs of wires must be connected for any network cable attached to this port.

## Safety

Complies with:

- IEC 60950-1: 2001
- EN 60950-1: 2002
- UL 60950-1 1st Ed.
- UL 2043
- CAN/CSA-C22.2 No. 60950-1-03

## EMC Compliance (Class B)

Complies with:

- FCC Part 15.107 and 15.109
- ICES-003 (Canada)
- VCCI

## Radio Signal Certification

Complies with:

- FCC Part 15, Subpart C and E
- RSS-210 (Canada), Issue 6 (September 2005)
- EN 300.328 V1.6.1 (2004-07)
- EN 301.893 V1.2.3 (2003-08)
- ARIB RCR STD-T66 (Ch 1~13), STD-33 (Ch 14), STD-71 (802.11a)
- DGT LP0002 (Taiwan)

## Immunity

- EN 301.489-1 V1.5.1 (2004-07)
- EN 301.489-17 V1.2.1 (2002-08)
- EN 60601-1-2

## Wireless

### 802.11b/g

<b>Radio Standard:</b>	IEEE 802.11b/g
<b>Radio Technology:</b>	Direct Sequence Spread Spectrum (DSSS) Orthogonal Frequency Division Multiplexing (OFDM)
<b>Data Rate:</b>	1, 2, 5.5, 6, 9, 11, 12, 18, 24, 36, 48, 54 Mbps per channel
<b>Operating Frequency:</b>	2.4 ~ 2.4835 GHz (US, Canada, ETSI) 2.4 ~ 2.497 GHz (Japan)
<b>Maximum Channels:</b>	FCC/IC: 1-11, ETSI: 1-13, MKK: 1-13 (802.11g), 1-14 (802.11b)
<b>Modulation Type:</b>	BPSK, QPSK, 16QAM, 64QAM / OFDM, BPSK, QPSK, CCK / DSSS
<b>Media Access Protocol:</b>	CSMA/CA with ACK
<b>Transmit Output Power:</b>	22 dBm (max)

### 802.11a

<b>Radio Standard:</b>	IEEE 802.11a
<b>Radio Technology:</b>	Orthogonal Frequency Division Multiplexing (OFDM)
<b>Data Rate:</b>	6, 9, 12, 18, 24, 36, 48, 54 Mbps per channel
<b>Operating Frequency:</b>	5.15 ~ 5.25 GHz (lower band) US, Canada, Japan, ETSI 5.25 ~ 5.35 GHz (middle band) US, Canada, ETSI 5.725 ~ 5.825 GHz (upper band) US, Canada 5.50 ~ 5.70 GHz ETSI
<b>Maximum Channels:</b>	FCC/IC: 12, ETSI: 19, MKK: 8
<b>Modulation Type:</b>	BPSK, QPSK, 16QAM, 64QAM
<b>Media Access Protocol:</b>	CSMA/CA with ACK
<b>Transmit Output Power:</b>	18 dBm (max)

## Receiver Sensitivity

Radio	ProCurve AP530 NA (J8986A)	ProCurve AP530 WW (J8987A)
802.11b (typical)	11Mbps @ -87dBm; 5.5Mbps @ -91dBm; 2Mbps @ -92dBm; 1Mbps @ -97dBm	11Mbps @ -87dBm; 5.5Mbps @ -89dBm; 2Mbps @ -91dBm; 1Mbps @ -94dBm
802.11g (typical)	54Mbps @ -74dBm; 48Mbps @ -75dBm; 36Mbps @ -80dBm; 24Mbps @ -83dBm; 18Mbps @ -86dBm; 12Mbps @ -88dBm; 9Mbps @ -90dBm; 6Mbps @ -91dBm	54Mbps @ -75dBm; 48Mbps @ -77dBm; 36Mbps @ -81dBm; 24Mbps @ -84dBm; 18Mbps @ -87dBm; 12Mbps @ -88dBm; 9Mbps @ -89dBm; 6Mbps @ -90dBm
802.11a (typical)	54Mbps @ -70dBm; 48Mbps @ -72dBm; 36Mbps @ -78dBm; 24Mbps @ -81dBm; 18Mbps @ -85dBm; 12Mbps @ -87dBm; 9Mbps @ -89dBm; 6Mbps @ -90dBm	54Mbps @ -70dBm; 48Mbps @ -72dBm; 36Mbps @ -78dBm; 24Mbps @ -81dBm; 18Mbps @ -84dBm; 12Mbps @ -87dBm; 9Mbps @ -88dBm; 6Mbps @ -89dBm

# Access Point Port and Network Cables

---

This appendix includes access point connector information and network cable information for cables that should be used with the Access Point 530, including minimum pin-out information and specifications for twisted-pair cables.

---

**Note**

---

Incorrectly wired cabling is the most common cause of problems for LAN communications. HP recommends that you work with a qualified LAN cable installer for assistance with your cabling requirements.

## Access Point Ports

The fixed RJ-45 10/100Base-TX port on the access point accepts 100-ohm unshielded twisted-pair cable with RJ-45 connectors as described on the next page.

## Twisted-Pair Cables

---

<b>10 Mbps Operation</b>	Category 3, 4, or 5 100-ohm unshielded twisted-pair (UTP), complying with IEEE 802.3 Type 10Base-T specifications, fitted with RJ-45 connectors
<b>100 Mbps Operation</b>	Category 5 100-ohm UTP cable, complying with IEEE 802.3u 100Base-TX specifications, fitted with RJ-45 connectors

---

## Twisted-Pair Cable/Connector Pin-Outs

The access point includes one 10/100Base-TX port. This port uses the “HP Auto MDIX” feature, which means that you can use either straight-through or crossover twisted-pair cables to connect the access point to a switch.

### **Other Wiring Rules:**

- All twisted-pair wires used for 10 Mbps, and 100 Mbps operation must be twisted through the entire length of the cable. The wiring sequence must conform to EIA/TIA 568-B (not USOC). See “Twisted-Pair Cable Pin Assignments” later in this appendix for a listing of the signals used on each pin.
- For 10 Mbps connections to the ports, you can use Category 3, 4, or 5 unshielded twisted-pair cable, as supported by the IEEE 802.3 Type 10Base-T standard.
- For 100 Mbps connections to the ports, use 100-ohm Category 5 UTP cable only, as supported by the IEEE 802.3u Type 100Base-TX standard.
- To provide Power over Ethernet to the access point, all 4 pairs must be connected for any network cable attached to this port; the cable must meet ISO/DIS 11801 Class D requirements and IEEE 802.3af requirements.

## Straight-Through Twisted-Pair Cable for 10 Mbps or 100 Mbps Network Connections

Because the 10/100 port on the access point supports auto-MDIX operation, you can use either “straight-through” or “crossover” cable for network connections to PCs, servers, hubs, or switches.

### Cable Diagram

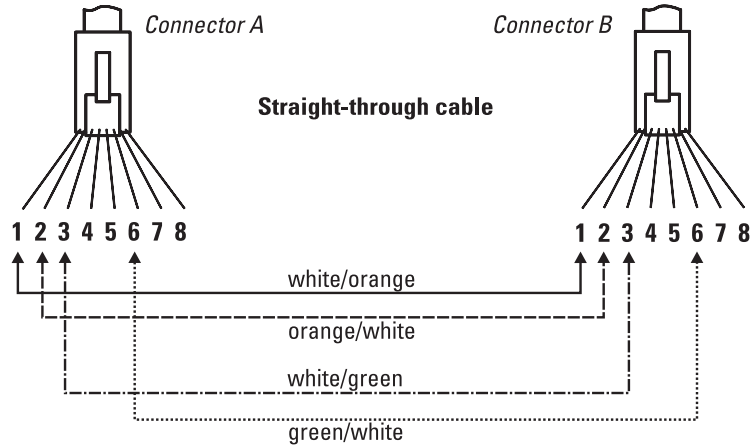

### Note

Pins 1 and 2 on connector “A” *must* be wired as a twisted pair to pins 1 and 2 on connector “B”.

Pins 3 and 6 on connector “A” *must* be wired as a twisted pair to pins 3 and 6 on connector “B”.

Pins 4, 5, 7, and 8 are not used for transmitting or receiving data, although they must be wired straight-through in the cable to support Power over Ethernet.

### Pin Assignments

Access Point End (MDI)		Hub or Switch Port, or Other MDI-X Port End	
Signal	Pins	Pins	Signal
receive +	1	1	transmit +
receive -	2	2	transmit -
transmit +	3	3	receive +
transmit -	6	6	receive -

## Crossover Twisted-Pair Cable for 10 Mbps or 100 Mbps Network Connection

Because the 10/100 port on the access point supports auto-MDIX operation, you can use either “straight-through” or “crossover” cable for network connections to PCs, servers, hubs, or switches.

### Cable Diagram

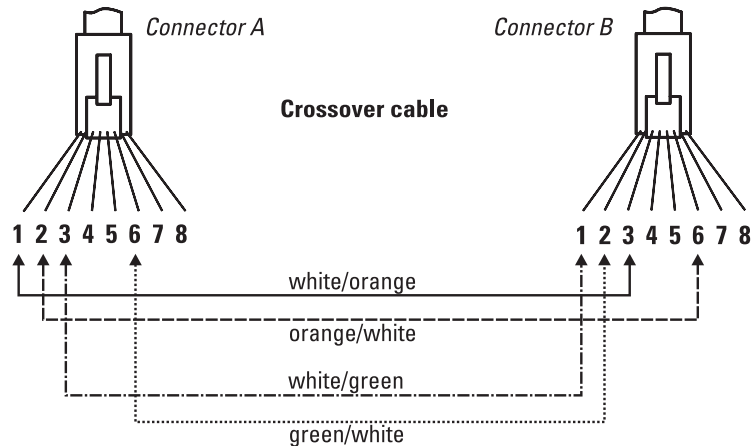

### Note

- Pins 1 and 2 on connector “A” *must* be wired as a twisted pair to pins 3 and 6 on connector “B”.
- Pins 3 and 6 on connector “A” *must* be wired as a twisted pair to pins 1 and 2 on connector “B”.
- Pins 4, 5, 7, and 8 are not used for transmitting or receiving data, although they must be wired straight-through in the cable to support Power over Ethernet.

### Pin Assignments

Access Point End (MDI)		Computer, Transceiver, or Other MDI Port End	
Signal	Pins	Pins	Signal
receive +	1	6	transmit -
receive -	2	3	transmit +
transmit +	3	2	receive -
transmit -	6	1	receive +

# Safety and EMC Regulatory Statements

---

## Safety Information



Documentation reference symbol. If the product is marked with this symbol, refer to the product documentation to get more information about the product.

### WARNING

A **WARNING** in the manual denotes a hazard that can cause injury or death.

### CAUTION

A **CAUTION** in the manual denotes a hazard that can damage the equipment or create a non-compliant condition.

Do not proceed beyond a **WARNING** or **CAUTION** notice until you have understood the hazardous conditions and have taken appropriate steps.

### Grounding

This product is a safety class I compliant product and has a protective earthing terminal. There must be an uninterruptible safety earth ground from the main power source to the product's power cord or supplied power cord set. Whenever it is likely that the protection has been impaired, disconnect the power cord until the ground has been restored.

For LAN cable grounding:

- If your LAN covers an area served by more than one power distribution system, be sure their safety grounds are securely interconnected.
- LAN cables may occasionally be subject to hazardous transient voltages (such as lightning or disturbances in the electrical utilities power grid). Handle exposed metal components of the network with caution.

### Servicing

There are no user-serviceable parts inside this product. Any servicing, adjustment, maintenance, or repair must be performed only by service-trained personnel.

This product does not have a power switch; it is powered on when the power cord is plugged in.

**Regulatory Model Identification Number**

For regulatory identification purposes, this product has been assigned a Regulatory Model Number (RMN). The RMN for your product is RSVLC-0501. The RMN should not be confused with the marketing name (Wireless Enterprise Access Point 530) or the Product Number (J8986A, J8987A).

---

## Informations concernant la sécurité



Symbole de référence à la documentation. Si le produit est marqué de ce symbole, reportez-vous à la documentation du produit afin d'obtenir des informations plus détaillées.

### WARNING

Dans la documentation, un WARNING indique un danger susceptible d'entraîner des dommages corporels ou la mort.

### CAUTION

Un texte de mise en garde intitulé CAUTION indique un danger susceptible de causer des dommages à l'équipement.

Ne continuez pas au-delà d'une rubrique WARNING ou CAUTION avant d'avoir bien compris les conditions présentant un danger et pris les mesures appropriées.

Cet appareil est un produit de classe I et possède une borne de mise à la terre. La source d'alimentation principale doit être munie d'une prise de terre de sécurité installée aux bornes du câblage d'entrée, sur le cordon d'alimentation ou le cordon de raccordement fourni avec le produit. Lorsque cette protection semble avoir été endommagée, débrancher le cordon d'alimentation jusqu'à ce que la mise à la terre ait été réparée.

Mise à la terre du câble de réseau local:

- si votre réseau local s'étend sur une zone desservie par plus d'un système de distribution de puissance, assurez-vous que les prises de terre de sécurité soient convenablement interconnectées.
- Les câbles de réseaux locaux peuvent occasionnellement être soumis à des surtensions transitoires dangereuses (telles que la foudre ou des perturbations dans le réseau d'alimentation public). Manipulez les composants métalliques du réseau avec précautions.

Aucune pièce contenue à l'intérieur de ce produit ne peut être réparée par l'utilisateur. Tout dépannage, réglage, entretien ou réparation devra être confié exclusivement à un personnel qualifié.

Cet appareil ne comporte pas de commutateur principal ; la mise sous tension est effectuée par branchement du cordon d'alimentation.

## Hinweise zur Sicherheit



Symbol für Dokumentationsverweis. Wenn das Produkt mit diesem Symbol markiert ist, schlagen Sie bitte in der Produktdokumentation nach, um mehr Informationen über das Produkt zu erhalten.

### WARNING

Eine WARNING in der Dokumentation symbolisiert eine Gefahr, die Verletzungen oder sogar Todesfälle verursachen kann.

### CAUTION

CAUTION in der Dokumentation symbolisiert eine Gefahr, die das Gerät beschädigen kann.

Fahren Sie nach dem Hinweis WARNING oder CAUTION erst fort, nachdem Sie den Gefahrezustand verstanden und die entsprechenden Maßnahmen ergriffen haben.

Dies ist ein Gerät der Sicherheitsklasse I und verfügt über einen schützenden Erdungsterminal. Der Betrieb des Geräts erfordert eine ununterbrochene Sicherheitserdung von der Hauptstromquelle zu den Geräteingabeterminals, den Netzkabeln oder dem mit Strom belieferten Netzkabelsatz voraus. Sobald Grund zur Annahme besteht, daß der Schutz beeinträchtigt worden ist, das Netzkabel aus der Wandsteckdose herausziehen, bis die Erdung wiederhergestellt ist.

Für LAN-Kabelerdung:

- Wenn Ihr LAN ein Gebiet umfaßt, das von mehr als einem Stromverteilungssystem beliefert wird, müssen Sie sich vergewissern, daß die Sicherheitserdungen fest untereinander verbunden sind.
- LAN-Kabel können gelegentlich gefährlichen Übergangsspannungen ausgesetzt werden (beispielsweise durch Blitz oder Störungen in dem Starkstromnetz des Elektrizitätswerks). Bei der Handhabung exponierter Metallbestandteile des Netzwerkes Vorsicht walten lassen.

Dieses Gerät enthält innen keine durch den Benutzer zu wartenden Teile. Wartungs-, Anpassungs-, Instandhaltungs- oder Reparaturarbeiten dürfen nur von geschultem Bedienungspersonal durchgeführt werden.

Dieses Gerät hat keinen Netzschalter; es wird beim Anschließen des Netzkabels eingeschaltet.

---

## Considerazioni sulla sicurezza



Simbolo di riferimento alla documentazione. Se il prodotto è contrassegnato da questo simbolo, fare riferimento alla documentazione sul prodotto per ulteriori informazioni su di esso.

### WARNING

La dicitura WARNING denota un pericolo che può causare lesioni o morte.

### CAUTION

La dicitura CAUTION denota un pericolo che può danneggiare le attrezzature.

Non procedere oltre un avviso di WARNING o di CAUTION prima di aver compreso le condizioni di rischio e aver provveduto alle misure del caso.

Questo prodotto è omologato nella classe di sicurezza I ed ha un terminale protettivo di collegamento a terra. Dev'essere installato un collegamento a terra di sicurezza, non interrompibile che vada dalla fonte d'alimentazione principale ai terminali d'entrata, al cavo d'alimentazione oppure al set cavo d'alimentazione fornito con il prodotto. Ogniqualvolta vi sia probabilità di danneggiamento della protezione, disinserite il cavo d'alimentazione fino a quando il collegaento a terra non sia stato ripristinato.

Per la messa a terra dei cavi LAN:

- se la vostra LAN copre un'area servita da più di un sistema di distribuzione elettrica, accertatevi che i collegamenti a terra di sicurezza siano ben collegati fra loro;
- i cavi LAN possono occasionalmente andare soggetti a pericolose tensioni transitorie (ad esempio, provocate da lampi o disturbi nella griglia d'alimentazione della società elettrica); siate cauti nel toccare parti esposte in metallo della rete.

Nessun componente di questo prodotto può essere riparato dall'utente. Qualsiasi lavoro di riparazione, messa a punto, manutenzione o assistenza va effettuato esclusivamente da personale specializzato.

Questo apparato non possiede un commutatore principale; si mette scotto tensione all'inserirsi il cavo d'alimentazione.

## Consideraciones sobre seguridad



**WARNING**

Símbolo de referencia a la documentación. Si el producto va marcado con este símbolo, consultar la documentación del producto a fin de obtener mayor información sobre el producto.

**CAUTION**

Una **WARNING** en la documentación señala un riesgo que podría resultar en lesiones o la muerte.

Una **CAUTION** en la documentación señala un riesgo que podría resultar en averías al equipo.

No proseguir después de un símbolo de **WARNING** o **CAUTION** hasta no haber entendido las condiciones peligrosas y haber tomado las medidas apropiadas.

Este aparato se enmarca dentro de la clase I de seguridad y se encuentra protegido por una borna de puesta a tierra. Es preciso que exista una puesta a tierra continua desde la toma de alimentación eléctrica hasta las bornas de los cables de entrada del aparato, el cable de alimentación o el juego de cable de alimentación suministrado. Si existe la probabilidad de que la protección a tierra haya sufrido desperfectos, desenchufar el cable de alimentación hasta haberse subsanado el problema.

Puesta a tierra del cable de la red local (LAN):

- Si la LAN abarca un área cuyo suministro eléctrico proviene de más de una red de distribución de electricidad, cerciorarse de que las puestas a tierra estén conectadas entre sí de modo seguro.
- Es posible que los cables de la LAN se vean sometidos de vez en cuando a voltajes momentáneos que entrañen peligro (rayos o alteraciones en la red de energía eléctrica). Manejar con precaución los componentes de metal de la LAN que estén al descubierto.

Este aparato no contiene pieza alguna susceptible de reparación por parte del usuario. Todas las reparaciones, ajustes o servicio de mantenimiento debe realizarlos solamente el técnico.

Este producto no tiene interruptor de potencia; se activa cuando se enchufa el cable de alimentación.

## Safety Information (Japan)

安全性の考慮

安全記号



マニュアル参照記号。製品にこの記号がついている場合はマニュアルを参照し、注意事項等をご確認ください。

**WARNING** マニュアル中の「WARNING」は人身事故の原因となる危険を示します。

**CAUTION** マニュアル中の「CAUTION」は装置破損の原因となる危険を示します。

「WARNING」や「CAUTION」の項は飛ばさないで必ずお読みください。危険性に関する記載事項をよく読み、正しい手順に従った上で次の事項に進んでください。

これは安全性クラス I の製品で保護用接地端子を備えています。主電源から製品の入力配線端子、電源コード、または添付の電源コード・セットまでの間、切れ目のない安全接地が存在することが必要です。もしこの保護回路が損なわれたことが推測されるときは、接地が修復されるまで電源コードを外しておいてください。

LAN ケーブルの接地に関して:

- もし貴社の LAN が複数の配電システムにより電力を受けている領域をカバーしている場合には、それらのシステムの安全接地が確実に相互に結合されていることを確認してください。
- LAN ケーブルは時として危険な過度電圧（例えば雷や、配電設備の電力網での障害）にさらされることがあります。露出した金属部分の取扱いには十分な注意をはらってください。

本製品の内部にはユーザーが修理できる部品はありません。サービス、調整、保守および修理はサービス訓練を受けた専門家におまかせください。

本製品には電源スイッチがありません。電源コードを接続したとき電源入となります。

# Safety Information (China)

## HP 网络产品使用安全手册

### 使用须知

欢迎使用惠普网络产品，为了您及仪器的安全，请您务必注意如下事项：

1. 仪器要和地线相接，要使用有正确接地插头的电源线，使用中国国家规定的220V电源。
2. 避免高温和尘土多的地方，否则易引起仪器内部部件的损坏。
3. 避免接近高温，避免接近直接热源，如直射太阳光、暖气等其它发热体。
4. 不要有异物或液体落入机内，以免部件短路。
5. 不要将磁体放置于仪器附近。

### 警告

为防止火灾或触电事故，请不要将该机放置于淋雨或潮湿处。

### 安装

安装辅助管理模块，请参看安装指南。

### 保修及技术支持

如果您按照以上步骤操作时遇到了困难，或想了解其它产品性能，请按以下方式与我们联系。

如是硬件故障：

1. 与售出单位或当地维修机构联系。
2. 中国惠普有限公司维修中心地址：  
北京市海淀区知春路49号希格玛大厦  
联系电话：010-62623888 转 6101  
邮政编码：100080

如是软件问题：

1. 惠普用户响应中心热线电话：010-65645959
2. 传真自动回复系统：010-65645735

---

# EMC Regulatory Statements

## Notice for U.S.A.

### Manufacturer's FCC Declaration of Conformity Statement

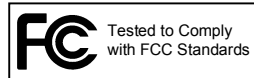

**Product No:** J8986A  
**Regulatory Model No:** RSVLC-0501  
**Manufacturer:** Hewlett-Packard Company  
3000 Hanover Street  
Palo Alto, CA 94304-1185 USA  
**Phone:** 650-857-1501

For questions regarding this declaration, contact the Product Regulations Manager at the above address or phone number.

This device complies with Part 15 of the FCC rules. Operation is subject to the following two conditions: 1) this device may not cause harmful interference, and 2) this device must accept any interference received, including interference that may cause undesired operation.

This equipment has been tested and found to comply with the limits for a Class B digital device, pursuant to Part 15 of the FCC Rules. These limits are designed to provide reasonable protection against harmful interference in a residential installation. This equipment generates, uses and can radiate radio frequency energy and, if not installed and used in accordance with instructions, may cause harmful interference to radio communications. However, there is no guarantee that the interference will not occur in a particular installation. If this equipment does cause harmful interference to radio or television reception, which can be determined by turning the equipment off and on, the user is encouraged to try to correct the interference by one or more of the following measures:

- Reorient the receiving antenna
- Increase the separation between the equipment and receiver
- Connect the equipment into an outlet on a circuit different from that to which the receiver is connected
- Consult the dealer or an experienced radio/TV technician for help

The FCC requires the user to be notified that any changes or modifications made to the device that are not expressly approved by the Hewlett-Packard Company may void the user's authority to operate the equipment.

If this device is going to be operated in the 5.15 ~ 5.25 GHz frequency range, then it is restricted to an indoor environment only.



**Warning: Exposure to Radio Frequency Radiation**

The radiated output power of this device is below the FCC radio exposure limits. Nevertheless, the device should be used in such a manner that the potential for human contact during normal operation is minimized. To avoid the possibility of exceeding the FCC radio frequency exposure limits, human proximity to the antennas should not be less than 25 cm (10 inches) during normal operation.

---

## Notice for Canada

This device complies with the limits for a Class B digital device and conforms to Industry Canada standard ICES-003. Products that contain a radio transmitter comply with Industry Canada standard RSS210 and are labeled with an IC approval number.

Cet appareil numérique de la classe B est conforme à la norme ICES-003 de Industry Canada. La radio sans fil de ce dispositif est conforme à la certification RSS 210 de Industry Canada et est étiquetée avec un numéro d'approbation IC.

This device complies with the Class B limits of Industry Canada. Operation is subject to the following two conditions: 1) this device may not cause harmful interference, and 2) this device must accept interference received, including interference that may cause undesired operation.

This device has been designed to operate with the antennas listed in this section, having a maximum gain of 13.8 dBi. Antennas not included in this list or having a gain greater than 13.8 dBi are strictly prohibited for use with this device. The required impedance is 50 ohms.

To reduce potential radio interference with other users, the antenna type and its gain should be so chosen that the equivalent isotropically radiated power (EIRP) is not more than that required for successful communication.

If this device is going to be operated in the 5.15 ~ 5.25 GHz frequency range, then it is restricted to an indoor environment only.

## Notice for European Community



This device complies with the EMC Directive 89/336/EEC, Low Voltage Directive 73/23/EEC and R&TTE Directive 1999/5/EC. Compliance with these directives implies conformity to harmonized European standards (European Norms) that are listed on the EU Declaration of Conformity that has been issued by HP for this device.

### Countries of Operation & Conditions of Use

This device may be used in the following EU and EFTA countries: Austria, Belgium, Cyprus, Czech Republic, Denmark, Estonia, Finland, France, Germany, Greece, Hungary, Iceland, Ireland, Italy, Latvia, Liechtenstein, Lithuania, Luxembourg, Malta, Netherlands, Norway, Poland, Portugal, Slovak Republic, Slovenia, Spain, Sweden, Switzerland and the United Kingdom. Requirements for indoor vs. outdoor operation, licensing and allowed channels of operation apply in some countries as described below.

---

#### Note

---

The user must use the configuration utility provided with this device to ensure the channels of operation are in conformance with the spectrum usage rules for EU and EFTA countries as described below.

#### 2.4 GHz Operation:

- This device may be operated indoors or outdoors in all EU and EFTA countries using the 2.4GHz band (Channels 1 - 13), except where noted below.
- In Italy, a license is required for outdoor use. Verify with your dealer or directly with the General Direction for Frequency Planning and Management (Direzione Generale Pianificazione e Gestione Frequenze).  
E' necessaria una concessione ministeriale anche per l'uso del prodotto. Verifici per favore con il proprio distributore o direttamente presso la Direzione Generale Pianificazione e Gestione Frequenze.
- In France, this device may use the entire 2400 - 2483.5 MHz band (Channels 1 through 13) for indoor applications. For outdoor use, only the 2400 - 2454 MHz frequency band (Channels 1 through 9) may be used. For the latest requirements, see <http://www.art-telecom.fr>.  
L'utilisation de cet équipement (2.4GHz wireless LAN) est soumise à certaines restrictions: cet équipement peut être utilisé à l'intérieur d'un bâtiment en utilisant toutes les fréquences de 2400 à 2483.5MHz (Chaîne

1-13). Pour une utilisation en environnement extérieur, vous devez utiliser les fréquences comprises entre 2400 à 2454-MHz (Chaîne 1-9). Pour les dernières restrictions, voir <http://www.art-telecom.fr>.

**5 GHz Operation:**

- This device requires the user or installer to properly enter the current country of operation in the 5 GHz Radio Configuration Window as described in the *AP530 Management and Configuration Guide*, before operating this device.
- This device will automatically limit the allowable channels determined by the current country of operation. Incorrectly entering the country of operation may result in illegal operation and may cause harmful interference to other systems. The user is obligated to ensure the device is operating according to the channel limitations, indoor/outdoor restrictions and license requirements for each European Community country as described in this document.
- This device employs a radar detection feature required for European Community and EFTA country operation in the 5 GHz band. This feature is automatically enabled when the country of operation is correctly configured for any European Community or EFTA country. The presence of nearby radar operation may result in temporary interruption of operation of this device. The radar detection feature will automatically restart operation on a channel free of radar.
- This device is restricted to indoor use when operated in EU and EFTA countries using the 5.15-5.35 GHz band (Channels 36, 40, 44, 48, 52, 56, 60 and 64). See the table below for the allowed 5 GHz channels in each band.

**Operation Using 5 GHz Channels in the European Community**

The user/installer must use the provided configuration utility to check the current channel of operation and make necessary configuration changes to ensure operation occurs in conformance with European National spectrum usage laws as described below and elsewhere in this document.

Frequency Band (MHz)	Allowed Channels	Usage	Maximum EIRP (mW)
5150 - 5250	36, 40, 44, 48	Indoor use only	200
5250 - 5350	52, 56, 60, 64	Indoor use only	200
5470 - 5725	100, 104, 108, 112, 116, 120, 124, 128, 132, 136, 140	Indoor or outdoor use	1000

## Transmit Power Control (TPC) for 5GHz Operation

This device employs Transmit Power Control (TPC) to reduce the potential for interference to other communication systems operating in the 5GHz frequency bands. The TPC feature implemented in this Wireless LAN device must be configured by the end-user when operating in any European Community or EFTA country. The end-user must follow the procedures explained in the *AP530 Management and Configuration Guide* in order to operate this device in accordance with European regulatory requirements for Transmit Power control.

---

### Note

---

The TPC procedure should be repeated when relocating this wireless device within the current wireless network or to a wireless network in a new location.

## Supported Antennas

The following table lists the available antennas for the ProCurve Wireless Access Point 530:

HP Product Number	Frequency Range (GHz)	Antenna Type	Actual Gain (dBi)
J8441A	2.4-2.5	Omni	4.4
J8444A	2.4-2.5	Omni	7.4
J8448B*	2.4-2.5	Yagi	13.8
J8997A	2.4-2.5 4.9-5.99	Omni	3/4
J8999A	2.4-2.5 4.9-5.99	Directional	6.9/7.7
J8998A	5.15-5.875	Omni	6.3
J9000A	5.15-5.875	Directional	13.3

\* A point-to-point antenna, accompanied with a pigtail cable, a 10 ft extension cable (model LMR-400), and a lightning arrester, which should be connected.

---

### CAUTION

- When using antennas outdoors, a lightning arrester is required for lightning protection. Consider placing the lightning arrester immediately before the antenna cable enters the building. ProCurve Networking offers a lightning arrester as an accessory; it is orderable under HP product number J8996A.

- All ProCurve Networking devices are designed to be compliant with the rules and regulations in locations they are sold and will be labeled as required. Any changes or modifications to ProCurve Networking equipment, not expressly approved by HP, could void the user's authority to operate this device. Use only antennas approved for use with this device. Unauthorized antennas, modifications, or attachments could cause damage and may violate local radio regulations in your region.
  - When using external antennas, users must ensure that the combined transmit power and antenna gain does not exceed the maximum Equivalent Isotropic Radiated Power (EIRP) for your region. Information on configuring this device for use with ProCurve external antennas is available on the ProCurve Networking Web site at: <http://www.procurve.com>.
-

## EU Declaration of Conformity

<b>DECLARATION OF CONFORMITY</b> according to ISO/IEC Guide 22 and EN 45014	
<b>Manufacturer's Name:</b>	Hewlett-Packard Company
<b>Manufacturer's Address:</b>	8000 Foothills Blvd. Roseville, CA 95747-5502 U.S.A.
<b>declares, that the product</b>	
<b>Product Name:</b>	HP Procurve Wireless Access Point 530
<b>Product Number(s):</b>	J8986A, J8987A
<b>Regulatory Model:</b>	RSVLC-0501
<b>Product Options:</b>	J8441A, J8444A, J8448A, J8997A, J8998A, J8999A, J9000A
<b>conforms to the following Product Specifications:</b>	
Safety:	EN 60950-1:2001 / IEC 60950-1:2002
Health:	EN 50385:2002
EMC:	EN 55022:1998 +A1+A2 / CISPR 22:1997 +A1+A2 Class B <sup>1</sup> EN 301 489-1 V1.4.1 (2002-08) EN 301 489-17 V1.2.1 (2002-08) EN 61000-3-2:2000 EN 61000-3-3:1995 +A1 EN 60601-1-2:2004 / IEC 60601-1-2:2004
Radio:	EN 300 328-1 V1.6.1 (2004-07) EN 301 893 V1.2.3 (2003-08)
<b>Supplementary Information:</b>	
The product herewith complies with the requirements of the Low Voltage Directive 73/23/EEC, the EMC Directive 89/336/EEC and the R&TTE Directive 1999/5/EC and carries the CE marking accordingly.	
1) The Product was tested in a typical configuration with a laptop computer.	
Roseville, February 2, 2006	 Mike Avery, Regulatory Engineering Mgr.
European Contact: Your local Hewlett-Packard Sales and Service Office or Hewlett-Packard GmbH, Department HQ-TRE, Herrenberger Straße 140, D-71034 Böblingen (FAX: + 49-7031-14-3143)	

## Notice for Japan

この機器の使用周波数帯では、電子レンジ等の産業・科学・医療用機器のほか工場の製造ライン等で使用されている移動体識別用の構内無線局（免許を要する無線局）及び特定小電力無線局（免許を要しない無線局）が運用されています。

1 この機器を使用する前に、近くで移動体識別用の構内無線局及び特定小電力無線局が運用されていないことを確認して下さい。

2 万一、この機器から移動体識別用の構内無線局に対して電波干渉の事例が発生した場合には、速やかに使用周波数を変更するか又は電波の発射を停止した上、下記連絡先にご連絡頂き、混信回避のための処置等（例えば、パーティションの設置など）についてご相談して下さい。

3 その他、この機器から移動体識別用の特定小電力無線局に対して電波干渉の事例が発生した場合など何かお困りのことが起きたときは、次の連絡先へお問い合わせ下さい。

連絡先：日本ヒューレット・パッカード株式会社 TEL：0120-014121

この装置は、情報処理装置等電波障害自主規制協議会（VCCI）の基準に基づくクラスB情報技術装置です。この装置は、家庭環境で使用することを目的としています。この装置がラジオやテレビジョン受信機に近接して使用されると受信障害を引き起こすことがあります。

取り扱い説明書に従って正しい取り扱いをして下さい。

## Notice for Taiwan

DGT LPD (Low Power Device) Statement:

### 低功率電波輻射性電機管理辦法

第十四條 經型式認證合格之低功率射頻電機，非經許可，公司、商號或使用者均不得擅自變更頻率、加大功率或變更原設計之特性及功能。

第十七條 低功率射頻電機之使用不得影響飛航安全及干擾合法通信；經發現有干擾現象時，應立即停用，並改善至無干擾時方得繼續使用。

前項合法通信，指依電信規定作業之無線電信。低功率射頻電機須忍受合法通信或工業、科學及醫療用電波輻射性電機設備之干擾。

## Notice for Korea

사용자 안내문 : A 급기기

이기는 업무용으로 전자파 적합등록을 받은 기기 이오니, 판매자 또는 사용자는 이점을 주의하시기 바라며, 만약 잘못 구입하셨을 때에는 구입한 곳에서 비업무용으로 교환하시기 바랍니다.

— *This page is intentionally unused.* —

# Recycle Statements

## Waste Electrical and Electronic Equipment (WEEE) Statements



### Disposal of Waste Equipment by Users in Private Household in the European Union

This symbol on the product or on its packaging indicates that this product must not be disposed of with your other household waste. Instead, it is your responsibility to dispose of your waste equipment by handing it over to a designated collection point for the recycling of waste electrical and electronic equipment. The separate collection and recycling of your waste equipment at the time of disposal will help to conserve natural resources and ensure that it is recycled in a manner that protects human health and the environment. For more information about where you can drop off your waste equipment for recycling, please contact your local city office, your household waste disposal service or the shop where you purchased the product.



### Likvidace zařízení soukromými domácími uživateli v Evropské unii

Tento symbol na produktu nebo balení označuje výrobek, který nesmí být vyhozen spolu s ostatním domácím odpadem. Povinností uživatele je předat takto označený odpad na předem určené sběrné místo pro recyklaci elektrických a elektronických zařízení. Okamžité třídění a recyklace odpadu pomůže uchovat přírodní prostředí a zajistí takový způsob recyklace, který ochrání zdraví a životní prostředí člověka. Další informace o možnostech odevzdání odpadu k recyklaci získáte na příslušném obecním nebo městském úřadě, od firmy zabývající se sběrem a svozem odpadu nebo v obchodě, kde jste produkt zakoupili.



### Bortskaffelse af affald fra husstande i den Europæiske Union

Hvis produktet eller dets emballage er forsynet med dette symbol, angiver det, at produktet ikke må bortskaffes med andet almindeligt husholdningsaffald. I stedet er det dit ansvar at bortskaffe kasseret udstyr ved at aflevere det på den kommunale genbrugsstation, der forestår genvinding af kasseret elektrisk og elektronisk udstyr. Den centrale modtagelse og genvinding af kasseret udstyr i forbindelse med bortskaffelsen bidrager til bevarelse af naturlige ressourcer og sikrer, at udstyret genvindes på en måde, der beskytter både mennesker og miljø. Yderligere oplysninger om, hvor du kan aflevere kasseret udstyr til genvinding, kan du få hos kommunen, den lokale genbrugsstation eller i den butik, hvor du købte produktet.



### Seadmete jäätmete kõrvaldamine eramajapidamistes Euroopa Liidus

See tootel või selle pakendil olev sümbol näitab, et kõnealust toodet ei tohi koos teiste majapidamisjäätmetega kõrvaldada. Teie kohus on oma seadmete jäätmed kõrvaldada, viies need elektri- ja elektroonikaseadmete jäätmete ringlussevõtmiseks selleks ettenähtud kogumispunkti. Seadmete jäätmete eraldi kogumine ja ringlussevõtmise kõrvaldamise ajal aitab kaitsta loodusvarasid ning tagada, et ringlussevõtmise toimub viisil, mis kaitseb inimeste tervist ning keskkonda. Lisateabe saamiseks selle kohta, kuhu oma seadmete jäätmed ringlussevõtmiseks viia, võtke palun ühendust oma kohaliku linnakantselei, majapidamisjäätmete kõrvaldamise teenistuse või kauplusega, kust Te toote ostsite.

## Recycle Statements

### Waste Electrical and Electronic Equipment (WEEE) Statements



#### Laitteiden hävittäminen kotitalouksissa Euroopan unionin alueella

Jos tuotteessa tai sen pakkauksessa on tämä merkki, tuotetta ei saa hävittää kotitalousjätteiden mukana. Tällöin hävitettävä laite on toimitettava sähkölaitteiden ja elektronisten laitteiden kierrätyspisteeseen. Hävitettävien laitteiden erillinen käsittely ja kierrätys auttavat säästämään luonnonvaroja ja varmistamaan, että laite kierrätetään tavalla, joka estää terveyshaitat ja suojelee luontoa. Lisätietoja paikoista, joihin hävitettävät laitteet voi toimittaa kierrätettäväksi, saa ottamalla yhteyttä jätehuoltoon tai liikkeeseen, josta tuote on ostettu.



#### Élimination des appareils mis au rebut par les ménages dans l'Union européenne

Le symbole apposé sur ce produit ou sur son emballage indique que ce produit ne doit pas être jeté avec les déchets ménagers ordinaires. Il est de votre responsabilité de mettre au rebut vos appareils en les déposant dans les centres de collecte publique désignés pour le recyclage des équipements électriques et électroniques. La collecte et le recyclage de vos appareils mis au rebut indépendamment du reste des déchets contribue à la préservation des ressources naturelles et garantit que ces appareils seront recyclés dans le respect de la santé humaine et de l'environnement. Pour obtenir plus d'informations sur les centres de collecte et de recyclage des appareils mis au rebut, veuillez contacter les autorités locales de votre région, les services de collecte des ordures ménagères ou le magasin dans lequel vous avez acheté ce produit.



#### Entsorgung von Altgeräten aus privaten Haushalten in der EU

Das Symbol auf dem Produkt oder seiner Verpackung weist darauf hin, dass das Produkt nicht über den normalen Hausmüll entsorgt werden darf. Benutzer sind verpflichtet, die Altgeräte an einer Rücknahmestelle für Elektro- und Elektronik-Altgeräte abzugeben. Die getrennte Sammlung und ordnungsgemäße Entsorgung Ihrer Altgeräte trägt zur Erhaltung der natürlichen Ressourcen bei und garantiert eine Wiederverwertung, die die Gesundheit des Menschen und die Umwelt schützt. Informationen dazu, wo Sie Rücknahmestellen für Ihre Altgeräte finden, erhalten Sie bei Ihrer Stadtverwaltung, den örtlichen Müllentsorgungsbetrieben oder im Geschäft, in dem Sie das Gerät erworben haben



#### Απορριψη άχρηστου εξοπλισμού από χρήστες σε ιδιωτικά νοικοκυριά στην Ευρωπαϊκή Ένωση

Το σύμβολο αυτό στο προϊόν ή τη συσκευασία του υποδεικνύει ότι το συγκεκριμένο προϊόν δεν πρέπει να διατίθεται μαζί με τα άλλα οικιακά σας απορρίμματα. Αντίθετα, είναι δική σας ευθύνη να απορρίψετε τον άχρηστο εξοπλισμό σας παραδίδοντάς τον σε καθορισμένο σημείο συλλογής για την ανακύκλωση άχρηστου ηλεκτρικού και ηλεκτρονικού εξοπλισμού. Η ξεχωριστή συλλογή και ανακύκλωση του άχρηστου εξοπλισμού σας κατά την απόρριψη θα συμβάλει στη διατήρηση των φυσικών πόρων και θα διασφαλίσει ότι η ανακύκλωση γίνεται με τρόπο που προστατεύει την ανθρώπινη υγεία και το περιβάλλον. Για περισσότερες πληροφορίες σχετικά με το πού μπορείτε να παραδώσετε τον άχρηστο εξοπλισμό σας για ανακύκλωση, επικοινωνήστε με το αρμόδιο τοπικό γραφείο, την τοπική υπηρεσία διάθεσης οικιακών απορριμμάτων ή το κατάστημα όπου αγοράσατε το προϊόν.



#### Készülékek magánháztartásban történő selejtezése az Európai Unió területén

A készüléken, illetve a készülék csomagolásán látható azonos szimbólum annak jelzésére szolgál, hogy a készülék a selejtezés során az egyéb háztartási hulladéktól eltérő módon kezelendő. A vásárló a hulladékká vált készüléket köteles a kijelölt gyűjtőhelyre szállítani az elektromos és elektronikai készülékek újrahasznosítása céljából. A hulladékká vált készülékek selejtezés kori begyűjtése és újrahasznosítása hozzájárul a természeti erőforrások megőrzéséhez, valamint biztosítja a selejtezett termékek környezetre és emberi egészségre nézve biztonságos feldolgozását. A begyűjtés pontos helyéről bővebb tájékoztatást a lakhelye szerint illetékes önkormányzattól, az illetékes személtakarító vállalattól, illetve a terméket elárusító helyen kaphat.



### **Smaltimento delle apparecchiature da parte di privati nel territorio dell'Unione Europea**

Questo simbolo presente sul prodotto o sulla confezione indica che il prodotto non può essere smaltito insieme ai rifiuti domestici. È responsabilità dell'utente smaltire le apparecchiature consegnandole presso un punto di raccolta designato al riciclo e allo smaltimento di apparecchiature elettriche ed elettroniche. La raccolta differenziata e il corretto riciclo delle apparecchiature da smaltire permette di proteggere la salute degli individui e l'ecosistema. Per ulteriori informazioni relative ai punti di raccolta delle apparecchiature, contattare l'ente locale per lo smaltimento dei rifiuti, oppure il negozio presso il quale è stato acquistato il prodotto.



### **Nolietotu iekārtu iznīcināšanas noteikumi lietotājiem Eiropas Savienības privātajās mājāsaimniecībās**

Šāds simbols uz izstrādājuma vai uz tā iesaiņojuma norāda, ka šo izstrādājumu nedrīkst izmest kopā ar citiem sadzīves atkritumiem. Jūs atbildat par to, lai nolietotās iekārtas tiktu nodotas speciāli iekārtotos punktos, kas paredzēti izmantoto elektrisko un elektronisko iekārtu savākšanai otrreizējai pārstrādei. Atsevišķa nolietoto iekārtu savākšana un otrreizējā pārstrāde palīdzēs saglabāt dabas resursus un garantēs, ka šīs iekārtas tiks otrreizēji pārstrādātas tādā veidā, lai pasargātu vidi un cilvēku veselību. Lai uzzinātu, kur nolietotās iekārtas var izmest otrreizējai pārstrādei, jāvērsas savas dzīves vietas pašvaldībā, sadzīves atkritumu savākšanas dienestā vai veikalā, kurā izstrādājums tika nopirkts.



### **Vartotojū iš privačių namų ūkių įrangos atliekų šalinimas Europos Sąjungoje**

Šis simbolis ant gaminio arba jo pakuotės rodo, kad šio gaminio šalinti kartu su kitomis namų ūkio atliekomis negalima. Šalintinas įrangos atliekas privalote pristatyti į specialią surinkimo vietą elektros ir elektroninės įrangos atliekoms perdirbti. Atskirai surenkamos ir perdirbamos šalintinos įrangos atliekos padės saugoti gamtinius išteklius ir užtikrinti, kad jos bus perdirbtos tokiu būdu, kuris nekenkia žmonių sveikatai ir aplinkai. Jeigu norite sužinoti daugiau apie tai, kur galima pristatyti perdirbtinas įrangos atliekas, kreipkitės į savo seniūniją, namų ūkio atliekų šalinimo tarnybą arba parduotuvę, kurioje įsigijote gaminį.



### **Verwijdering van afgedankte apparatuur door privé-gebruikers in de Europese Unie**

Dit symbool op het product of de verpakking geeft aan dat dit product niet mag worden gedeponeerd bij het normale huishoudelijke afval. U bent zelf verantwoordelijk voor het inleveren van uw afgedankte apparatuur bij een inzamelingspunt voor het recyclen van oude elektrische en elektronische apparatuur. Door uw oude apparatuur apart aan te bieden en te recyclen, kunnen natuurlijke bronnen worden behouden en kan het materiaal worden hergebruikt op een manier waarmee de volksgezondheid en het milieu worden beschermd. Neem contact op met uw gemeente, het afvalinzamelingsbedrijf of de winkel waar u het product hebt gekocht voor meer informatie over inzamelingspunten waar u oude apparatuur kunt aanbieden voor recycling.



### **Pozbywanie się zużytego sprzętu przez użytkowników w prywatnych gospodarstwach domowych w Unii Europejskiej**

Ten symbol na produkcie lub jego opakowaniu oznacza, że produktu nie wolno wyrzucać do zwykłych pojemników na śmieci. Obowiązkiem użytkownika jest przekazanie zużytego sprzętu do wyznaczonego punktu zbiórki w celu recyklingu odpadów powstałych ze sprzętu elektrycznego i elektronicznego. Osobna zbiórka oraz recykling zużytego sprzętu pomogą w ochronie zasobów naturalnych i zapewnią ponowne wprowadzenie go do obiegu w sposób chroniący zdrowie człowieka i środowisko. Aby uzyskać więcej informacji o tym, gdzie można przekazać zużyty sprzęt do recyklingu, należy się skontaktować z urzędem miasta, zakładem gospodarki odpadami lub sklepem, w którym zakupiono produkt.



#### Descarte de Lixo Elétrico na Comunidade Européia

Este símbolo encontrado no produto ou na embalagem indica que o produto não deve ser descartado no lixo doméstico comum. É responsabilidade do cliente descartar o material usado (lixo elétrico), encaminhando-o para um ponto de coleta para reciclagem. A coleta e a reciclagem seletivas desse tipo de lixo ajudarão a conservar as reservas naturais; sendo assim, a reciclagem será feita de uma forma segura, protegendo o ambiente e a saúde das pessoas. Para obter mais informações sobre locais que reciclam esse tipo de material, entre em contato com o escritório da HP em sua cidade, com o serviço de coleta de lixo ou com a loja em que o produto foi adquirido.



#### Likvidácia vyradených zariadení v domácnostiach v Európskej únii

Symbol na výrobku alebo jeho balení označuje, že daný výrobok sa nesmie likvidovať s domovým odpadom. Povinnosťou spotrebiteľa je odovzdať vyradené zariadenie v zbernom mieste, ktoré je určené na recykláciu vyradených elektrických a elektronických zariadení. Separovaný zber a recyklácia vyradených zariadení prispieva k ochrane prírodných zdrojov a zabezpečuje, že recyklácia sa vykonáva spôsobom chrániacim ľudské zdravie a životné prostredie. Informácie o zberných miestach na recykláciu vyradených zariadení vám poskytne miestne zastupiteľstvo, spoločnosť zabezpečujúca odvoz domového odpadu alebo obchod, v ktorom ste si výrobok zakúpili.



#### Odstranjevanje odslužene opreme uporabnikov v zasebnih gospodinjstvih v Evropski uniji

Ta znak na izdelku ali njegovi embalaži pomeni, da izdelka ne smete odvreči med gospodinjске odpadke. Nasprotno, odsluženo opremo morate predati na zbirališče, pooblaščno za recikliranje odslužene električne in elektronske opreme. Ločeno zbiranje in recikliranje odslužene opreme prispeva k ohranjanju naravnih virov in zagotavlja recikliranje te opreme na zdravju in okolju neškodljiv način. Za podrobnejše informacije o tem, kam lahko odpeljete odsluženo opremo na recikliranje, se obrnite na pristojni organ, komunalno službo ali trgovino, kjer ste izdelek kupili.



#### Eliminación de residuos de equipos eléctricos y electrónicos por parte de usuarios particulares en la Unión Europea

Este símbolo en el producto o en su envase indica que no debe eliminarse junto con los desperdicios generales de la casa. Es responsabilidad del usuario eliminar los residuos de este tipo depositándolos en un "punto limpio" para el reciclado de residuos eléctricos y electrónicos. La recogida y el reciclado selectivos de los residuos de aparatos eléctricos en el momento de su eliminación contribuirá a conservar los recursos naturales y a garantizar el reciclado de estos residuos de forma que se proteja el medio ambiente y la salud. Para obtener más información sobre los puntos de recogida de residuos eléctricos y electrónicos para reciclado, póngase en contacto con su ayuntamiento, con el servicio de eliminación de residuos domésticos o con el establecimiento en el que adquirió el producto.



#### Bortskaffande av avfallsprodukter från användare i privathushåll inom Europeiska Unionen

Om den här symbolen visas på produkten eller förpackningen betyder det att produkten inte får slängas på samma ställe som hushållssopor. I stället är det ditt ansvar att bortskaffa avfallet genom att överlämna det till ett uppsamlingsställe avsett för återvinning av avfall från elektriska och elektroniska produkter. Separat insamling och återvinning av avfallet hjälper till att spara på våra naturresurser och gör att avfallet återvinns på ett sätt som skyddar människors hälsa och miljön. Kontakta ditt lokala kommunkontor, din närmsta återvinningsstation för hushållsavfall eller affären där du köpte produkten för att få mer information om var du kan lämna ditt avfall för återvinning.

---

# Index

## Numerics

- 10/100Base-TX
  - connections, length limitations ... 2-4
  - ports, cables used with ... 2-4
- 10/100Base-TX port
  - location on access point ... 1-5

## A

- access point
  - connecting to a power source ... 2-12
  - description ... 1-1
  - downloading new software ... 5-10
  - electrical specifications ... A-1
  - emissions specifications ... A-2
  - environmental specifications ... A-1
  - external antenna options ... 4-2
  - features ... 1-9
  - included parts ... 2-1
  - LED descriptions ... 1-4
  - mounting on a wall ... 2-7, 2-10
  - mounting on horizontal surface ... 2-12
  - physical specifications ... A-1
  - top panel description ... 1-3
- access point operation
  - verifying after installation ... 2-5
- antennas
  - external options ... 4-2
  - location on access point ... 1-5
- auto MDI/MDI-X operation ... B-3
- Auxiliary port
  - description ... 1-8
  - location on access point ... 1-8

## B

- back of access point
  - 10/100Base-TX port ... 1-5
  - Auxiliary port ... 1-8
  - Clear button ... 1-8
  - console port ... 1-6
  - description ... 1-5
  - lock ... 1-6
  - network port ... 1-6
  - power connector ... 1-6
  - Reset button ... 1-7
- basic access point configuration
  - command line interface ... 3-2
- basic troubleshooting tips ... 5-1
- blinking LEDs
  - error indications ... 5-3
- buttons
  - Clear button ... 1-8
  - Reset button ... 1-7

## C

- cables
  - 10/100Base-TX connections ... 2-4
  - connecting cables to the access point
    - port ... 2-13
  - effects of non-standard cables ... 5-2
  - infrastructure requirements ... 2-4
  - length limitations ... 2-4
  - required types ... 2-4, 4-2
  - serial, for direct console connection ... 2-15
- cables, twisted pair
  - access point-to-computer connection ... B-3
  - access point-to-switch or hub connection ... B-4
  - category 3, 4, 5 ... B-2
  - cross-over cable pin-out ... B-4
  - MDI-X to MDI connections ... B-3
  - MDI-X to MDI-X connections ... B-4
  - pin-outs ... B-3
  - straight-through cable pin-out ... B-3
- cables, twisted-pair
  - wiring rules ... B-2
- cables, twisted-pair connector pin-outs ... B-2

- cabling infrastructure ... 2-4
  - Clear button
    - description ... 1-8
    - location on access point ... 1-8
    - to delete password protection ... 3-8
  - CLI prompt, console
    - displaying ... 2-16
  - command line interface
    - key command descriptions ... 3-7
  - configuration
    - command line interface ... 3-2
    - DHCP ... 3-2
    - IP address, manually ... 3-2
    - restoring factory defaults ... 5-8
  - connecting the access point to a power source ... 2-12
  - connector specifications ... A-2
  - console
    - checking messages during troubleshooting ... 5-6
    - command line interface ... 3-2
    - displaying the CLI prompt ... 2-16
    - features ... 2-14
    - how to connect in-band ... 2-14
    - how to connect out-of-band ... 2-14
    - serial cable connection ... 2-15
    - SSH access ... 3-10
    - Telnet access ... 3-9
    - terminal configuration ... 2-14
  - console port
    - location on access point ... 1-5–1-6
  - cross-over cable
    - pin-out ... B-4
- D**
- DC power connector
    - location on back of access point ... 1-5
  - description
    - access point ... 1-1
    - back of access point ... 1-5
    - LEDs ... 1-4
    - top of access point ... 1-3
  - DHCP
    - automatic access point configuration ... 3-2
    - for in-band access ... 2-14
  - diagnostic tests ... 5-6
    - checking the console messages ... 5-6
    - checking the LEDs ... 5-6
    - end-to-end connectivity ... 5-7
    - testing the access point only ... 5-6
    - testing twisted-pair cabling ... 5-7
  - downloading new access point software ... 5-10
- E**
- electrical specifications, access point ... A-1
  - EMC regulatory statements ... C-9
  - emissions specifications, access point ... A-2
  - environmental specifications, access point ... A-1
  - external antenna options ... 4-2
- F**
- factory default configuration, restoring ... 5-8
  - features
    - access point ... 1-9
    - console ... 2-14
  - full-duplex fixed configuration
    - effects on network connections ... 5-1
- H**
- horizontal surface
    - mounting access point on ... 2-12
- I**
- in-band ... 3-1
  - in-band console access
    - types of ... 2-14
  - included parts ... 2-1
  - installation
    - connecting the access point to a power source ... 2-12
    - horizontal surface mounting ... 2-12
    - location considerations ... 2-4, 4-3
    - network cable requirements ... 2-4
    - precautions ... 2-3
    - site preparation ... 2-4
    - summary of steps ... 2-2
    - wall mounting ... 2-7, 2-10

**L**

- LAN LED ... 1-4
  - behaviors ... 1-4
- LEDs
  - behavior during system initialization ... 2-6
  - checking during troubleshooting ... 5-6
  - descriptions of ... 1-4
  - error indications ... 5-3
  - LAN ... 1-4
  - location on access point ... 1-3
  - on access point ... 1-4
  - Power ... 1-4
    - behavior during system initialization ... 2-6
    - Wireless ... 1-4
- length limitations
  - 10/100Base-TX connections ... 2-4
- location for the access point, considerations ... 2-4, 4-3
- lock
  - location on access point ... 1-6

**M**

- MDI-X to MDI network cable ... B-3
- MDI-X to MDI-X network cable ... B-4
- mounting the access point
  - on a horizontal surface ... 2-12
  - on a wall ... 2-7, 2-10
  - precautions ... 2-7

**N**

- network cables
  - 10/100Base-TX connections ... 2-4
  - required types ... 2-4
  - twisted-pair connector pin-outs ... B-2
  - twisted-pair, wiring rules ... B-2
- network devices
  - connecting to the access point ... 2-13
- network ports
  - connecting to ... 2-13
  - location on access point ... 1-6
  - standards compliance ... A-2
  - types of ... 2-4, 4-2
- non-standard network cables, effects ... 5-2

**O**

- out-of-band console access ... 3-9

**P**

- parts, included with the access point ... 2-1
- passwords
  - deleting with the Clear button ... 3-8
  - if you lose the password ... 3-8
- physical specifications, access point ... A-1
- Ping test ... 5-7
- pin-outs
  - twisted-pair cables ... B-2
- PoE power connector
  - location on back of access point ... 1-5
- port LEDs
  - normal operation ... 2-6
- ports
  - 10/100Base-TX, location on access point ... 1-5
  - connecting to ... 2-13
  - console ... 2-14
  - network connections ... 2-13
- power connector ... 1-6
- Power LED ... 1-4
  - behavior during system initialization ... 2-6
  - behaviors ... 1-4
  - location on access point ... 1-3
- power source
  - connecting the access point to ... 2-12
- precautions
  - mounting the access point ... 2-3
  - power requirements ... 2-3
- preparing the installation site ... 2-4
- Proactive Network tools
  - diagnostics with ... 5-5

**R**

- recycle statements ... D-1
- regulatory statements ... C-9
- Reset button
  - description ... 1-7
  - location on access point ... 1-7
- resetting the access point
  - factory default reset ... 5-8
  - location of Reset button ... 1-7
  - troubleshooting procedure ... 5-6

**S**

- safety and regulatory statements ... C-1
- safety specifications ... A-2
- serial cable
  - for direct console connection ... 2-15
- sides of access point
  - antennas ... 1-5
- specifications
  - connectors ... A-2
  - electrical ... A-1
  - emissions ... A-2
  - environmental ... A-1
  - physical ... A-1
  - safety ... A-2
  - wireless ... A-3
- SSH access to the console ... 3-10
- straight-through cable
  - pin-out ... B-3
- summary
  - of access point installation ... 2-2
  - of cables used with the access point ... 2-4, 4-2
- system initialization
  - LED behavior during ... 2-6
  - Power LED behavior ... 2-6

**T**

- Telnet access to the console ... 3-9
- terminal configuration ... 2-14
- testing
  - access point operation ... 5-6
  - access point-to-device communications ... 5-7
  - checking the console messages ... 5-6
  - checking the LEDs ... 5-6
  - diagnostic tests ... 5-6
  - end-to-end communications ... 5-7
  - Ping test ... 5-7
  - twisted-pair cabling ... 5-7
- tips for troubleshooting ... 5-1
- top of access point ... 1-3
  - description ... 1-3
  - LEDs ... 1-4
- topologies
  - effects of improper topology ... 5-2
  - samples of ... 2-17

- troubleshooting ... 5-1
  - basic tips ... 5-1
  - checking the console messages ... 5-6
  - checking the LEDs ... 5-6
  - common network problems ... 5-1
  - connecting to fixed full-duplex devices ... 5-1
  - diagnostic tests ... 5-6
  - effects of improper topology ... 5-2
  - effects of non-standard cables ... 5-2
  - Ping test ... 5-7
  - Proactive Network tools ... 5-5
  - restoring factory default configuration ... 5-8
  - testing connections to other devices ... 5-7
  - testing end-to-end communications ... 5-7
  - testing the access point ... 5-6
  - testing the twisted-pair cables ... 5-7
- twisted-pair cable
  - access point-to-computer connection ... B-3
  - access point-to-switch or hub connection ... B-4
  - cross-over cable pin-out ... B-4
  - pin-outs ... B-2–B-3
  - straight-through cable pin-out ... B-3
  - testing ... 5-7

**V**

- VCCI compliance ... C-16
- VT-100 terminal
  - serial cable connection for ... 2-15

**W**

- wall
  - mounting access point on ... 2-7, 2-10
- warranty ... 1-ii
- wireless infrastructure
  - topology with ... 2-18
- wireless infrastructure for roaming stations
  - topology with ... 2-19
- Wireless LED ... 1-4
  - behaviors ... 1-4
- wireless specifications ... A-3
- wiring rules for twisted-pair cables ... B-2





Technical information in this document  
is subject to change without notice.

© Copyright 2006  
Hewlett-Packard Development Company, L.P.  
Reproduction, adaptation, or translation  
without prior written permission is prohibited  
except as allowed under the copyright laws.

Printed in Taiwan  
May 2006

Manual Part Number  
5991-2192

